

Precision Ballscrew EBC

- Single nut according to DIN 69051 (1989) with flange form C
- Preload by ball selection (ground) or without preload (precision rolled)
- Ground or precision rolled screw shafts available

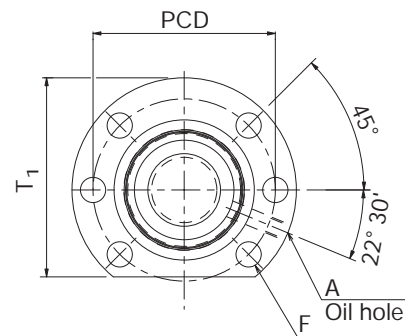
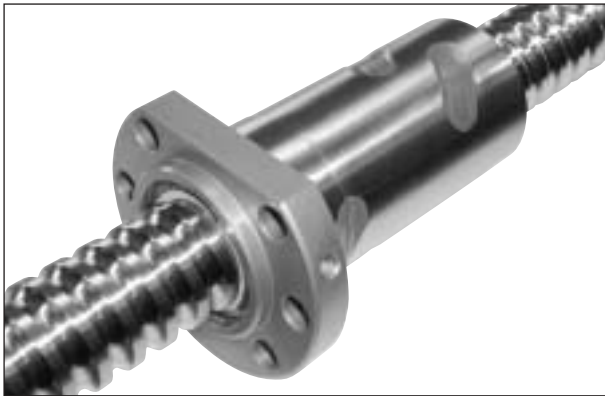

Drilling template 1

Model number	Screw shaft diameter d	Lead ℓ	Ball center-to-center diameter dp	Thread minor diameter d ₃	No. of loaded circuits/rows × turns	Basic load rating		Rigidity ¹⁾ K [N/μm]
						C _a [kN]	C _{0a} [kN]	
* EBC1605-4RR	16	5	16.75	13.5	4×1	10.2	17.0	237
* EBC2005-3RR	20	5	20.75	17.5	3×1	9.2	16.9	219
* EBC2505-3RR	25	5	25.75	22.5	3×1	10.5	22.2	266
* EBC2510-3RR	25	10	26	21.9	3×1	13.9	26.4	271
* EBC2510-4RR	25	10	26	21.9	4×1	17.7	35.2	356
* EBC3205-3RR	32	5	32.75	29.5	3×1	11.9	29.6	327
* EBC3205-4RR	32	5	32.75	29.5	4×1	15.3	39.5	430
* EBC3205-6RR	32	5	32.75	29.5	6×1	21.6	59.2	634
* EBC3210-3RR	32	10	33.75	27.2	3×1	27.9	51.0	345
* EBC3210-4RR	32	10	33.75	27.2	4×1	35.8	68.0	454
EBC4005-6RR	40	5	40.75	37.5	6×1	24.1	76.1	762
* EBC4010-3RR	40	10	41.75	35.2	3×1	32.4	67.8	421
* EBC4010-4RR	40	10	41.75	35.2	4×1	41.5	90.4	553
* EBC4020-3RR	40	20	41.75	35.2	3×1	30.7	63.3	413
EBC5005-6RR	50	5	50.75	47.5	6×1	26.6	97.3	914
EBC5010-4RR	50	10	51.75	45.2	4×1	47.2	118.5	671
EBC5020-3RR	50	20	52.25	45.2	3×1	45.9	137.8	509
EBC6310-6RR	63	10	64.75	58.2	6×1	76.4	236.8	1217
EBC6320-3RR	63	20	65.7	56.0	3×1	80.2	212.0	673

* Also available with precision rolled screw shaft (Cp3 und Cp5).

¹⁾ The rigidity values in this table indicate spring constants obtained from the load and elastic displacement under a preload of 10% of the basic dynamic load rating C_a, and an axial load F_a that is three times that of the preload F_{a0}. As these values do not take into account the rigidity of the parts involved in the nut installation, take 80% of the values given in this table as a general guideline.

If the preload F_{a0} differs from 0.1 C_a, the rigidity K_N can be calculated using the following equation:

$$K_N = K \cdot \left(\frac{F_{a0}}{0.1 C_a} \right)^{\frac{1}{3}} \cdot 0.8$$

If the ballscrew is not preloaded, please consult **THK** for the rigidity value.

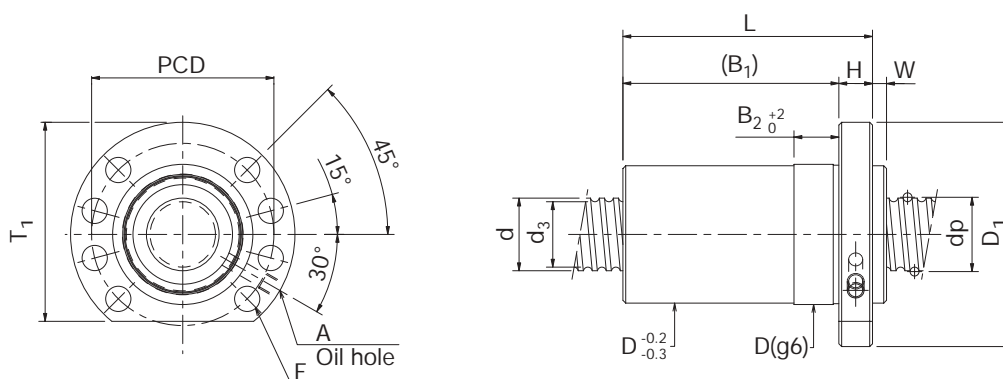

Drilling template 2

Unit: mm

Nut dimensions												Screw shaft inertial moment per mm [kg·cm ² /mm]
Outer diameter D	Flange diameter D ₁	Overall length L	H	B ₁	B ₂	W	T ₁	PCD	F	Drilling template	Oil hole A	
28	48	50	10	40	10	5	44	38	5.5	1	M6×1	5.05×10 ⁻⁴
36	58	45	10	35	10	5	51	47	6.6	1	M6×1	1.23×10 ⁻³
40	62	45	10	35	10	5	55	51	6.6	1	M6×1	3.01×10 ⁻³
40	62	75	10	65	16	5	55	51	6.6	1	M6×1	3.01×10 ⁻³
40	62	80	10	70	16	5	55	51	6.6	1	M6×1	3.01×10 ⁻³
50	80	47	12	35	10	5	71	65	9	1	M6×1	8.08×10 ⁻³
50	80	52	12	40	10	5	71	65	9	1	M6×1	8.08×10 ⁻³
50	80	62	12	50	10	5	71	65	9	1	M6×1	8.08×10 ⁻³
50	80	77	12	65	16	5	71	65	9	1	M6×1	8.08×10 ⁻³
50	80	89	12	77	16	5	71	65	9	1	M6×1	8.08×10 ⁻³
63	93	65	14	51	10	5	81.5	78	9	2	M8×1	1.97×10 ⁻²
63	93	79	14	65	16	5	81.5	78	9	2	M8×1	1.97×10 ⁻²
63	93	89	14	75	16	5	81.5	78	9	2	M8×1	1.97×10 ⁻²
63	93	119	14	105	25	10	81.5	78	9	2	M8×1	1.97×10 ⁻²
75	110	70	16	54	10	5	97.5	93	11	2	M8×1	4.82×10 ⁻²
75	110	91	16	75	16	5	97.5	93	11	2	M8×1	4.82×10 ⁻²
75	110	124	16	108	25	10	97.5	93	11	2	M8×1	4.82×10 ⁻²
90	125	114	18	96	16	5	104.5	108	11	2	M8×1	1.21×10 ⁻¹
95	135	126	18	108	25	10	117.5	115	13.5	2	M8×1	1.21×10 ⁻¹

Model-Number Coding

EBC 32 05 – 4 RR G0 + 1200L Cp5

(1) (2) (3) (4) (5) (6) (7) (8)

- (1) Nut
- (2) Screw shaft outer diameter (mm)
- (3) Lead (mm)
- (4) Number of circuits (rows × turns)
- (5) Seals (RR: labyrinth seals attached to both sides)

- (6) Symbol for preload
G0 = preloaded
GT = without clearance
- (7) Screw shaft total length (mm)
- (8) Accuracy (see page 10 - 15)