



LM Guide Actuator **KR**



Modularized to reduce work hours and  
make moving parts more compact.  
Versatile size options.

# Front Runner

# KR LM Guide Actuator

THK has sold LM Guide actuators for use in various applications for over 30 years in more than 40 countries worldwide.

Introduced as a pioneer of modular products, the lineup has grown to include nine sizes and has been met with high praise from customers.

Even now, as a compact actuator front runner, it continues to help customers solve problems in a wide variety of fields, such as transport, inspection, and assembly.



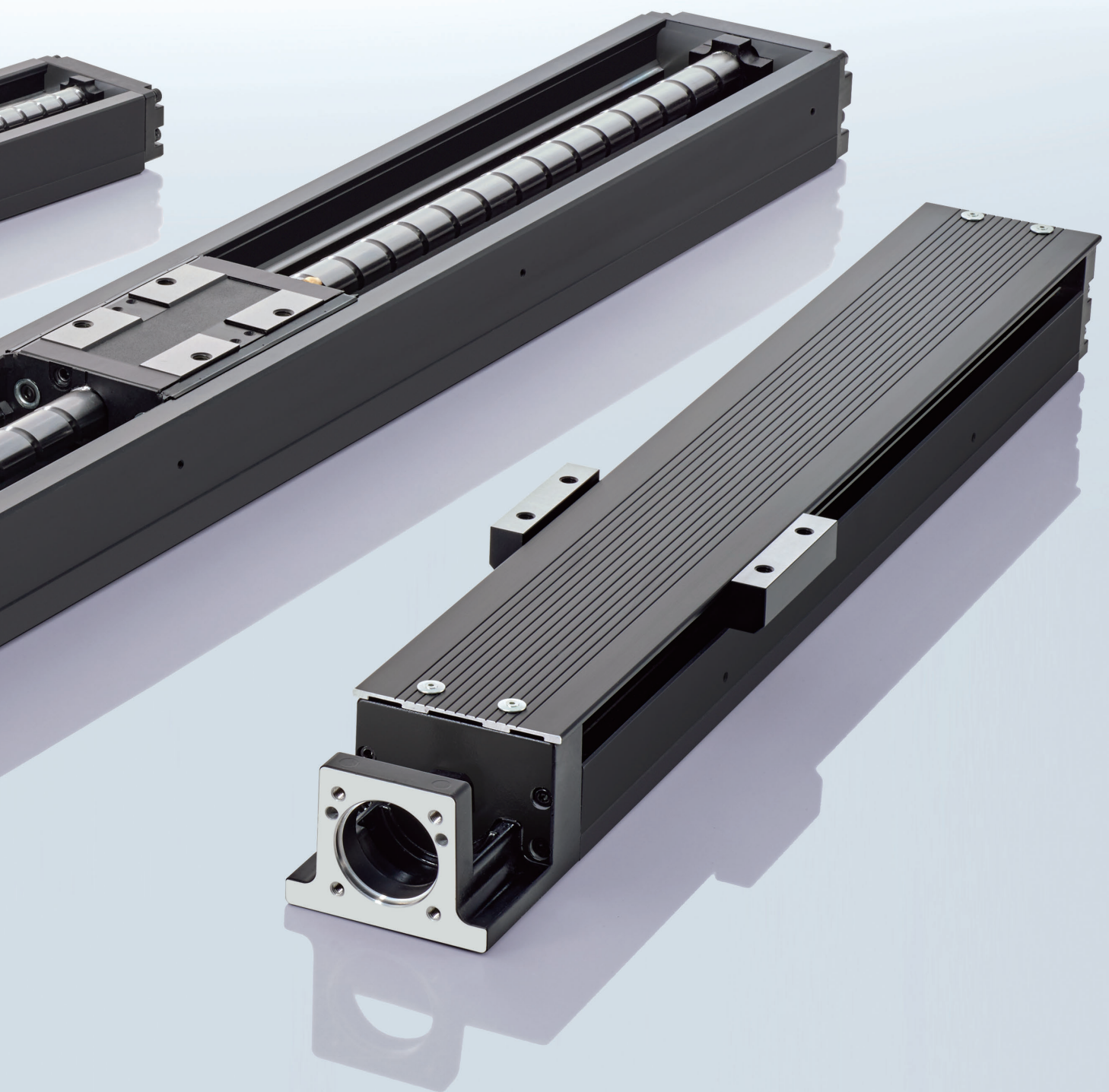

# The many advantages of

## Feature 1

## Compact Structure (Combined Modules)

KR actuators have a structure embedding an inner block, which consists of an LM block and ball screw nut, in an outer rail with a U-shaped cross-section. They have achieved significant miniaturization compared to conventional products. They can easily be combined with other devices, which further contributes to miniaturization of those devices.

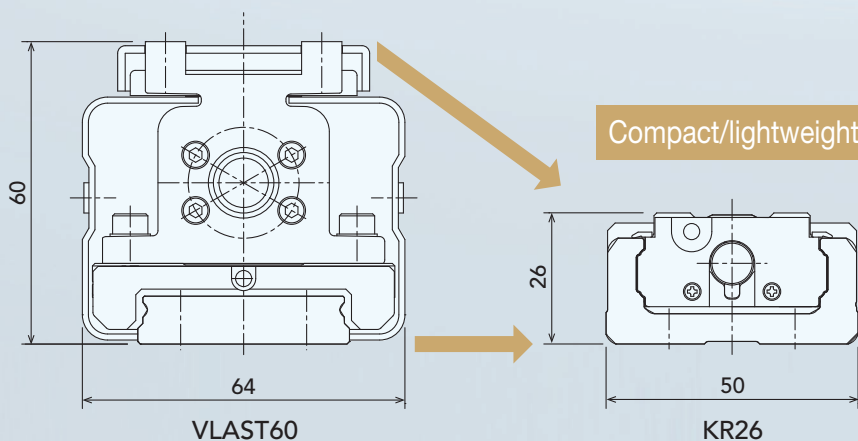

Sectional dimensions

66%

Mass

31%  
reduction!

## Feature 2

## High-Rigidity Structure (Outer Rail with a U-Shaped Cross-Section)

Excellent high rigidity is achieved by using an outer rail with a U-shaped cross-section to create a structure resilient against torsion, bending, and deflection that enables a larger moment to be received. It is also suitable for applications with long overhangs such as the top axis of XY axes.

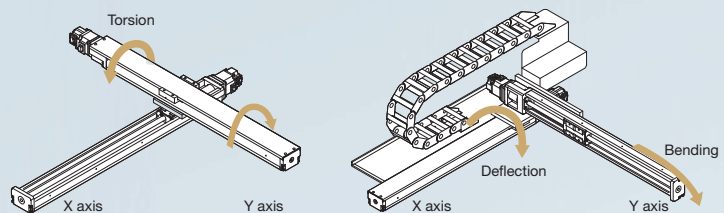

Geometric moment of inertia around the Y axis

Approx. 2.8x

Geometric moment of inertia around the X axis

Approx. 5.8x

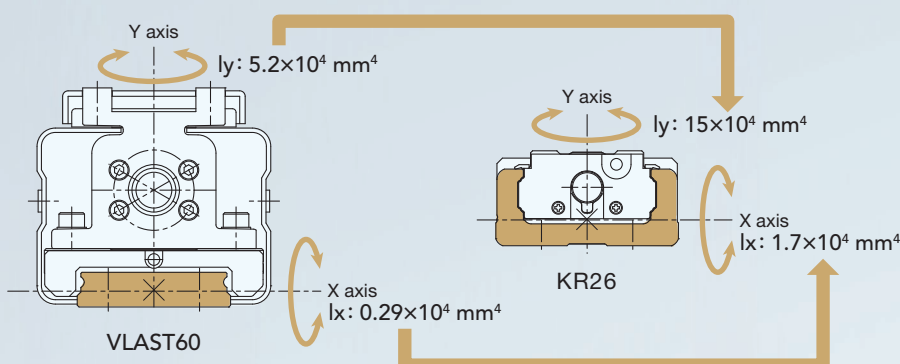

# THK's original structure

## Feature 3

### Can Be Used in Any Orientation (Same Rated Load in 4 Directions)

Each row of balls in the linear guide is arranged at a 45° contact angle, achieving the same rated load performance for each of the 4 directions (radial, reverse-radial, and horizontal directions) acting on the inner block. It can be used in any orientation.

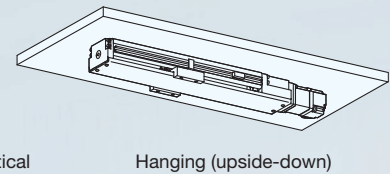
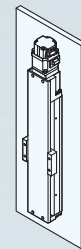
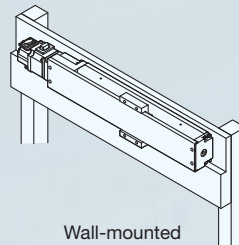
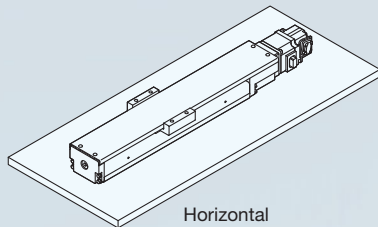
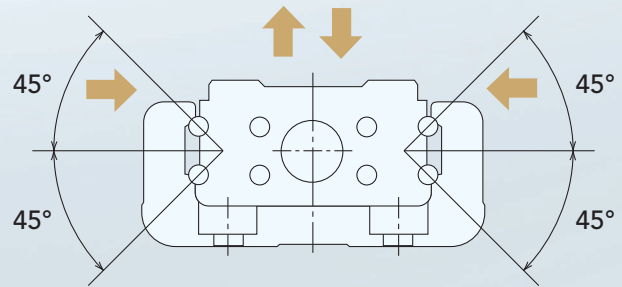

## Feature 4

### High Precision

The linear motion guide is a clearance-free, highly rigid guide that features four rows of circular arc grooves with a two-point contact structure, which allows light movement even when a preload is applied. In addition, it enables high-precision feeding by minimizing changes in friction resistance caused by varying loads. It achieves precision-grade positioning for all types of devices, contributing to improved high-precision and high-quality performance.

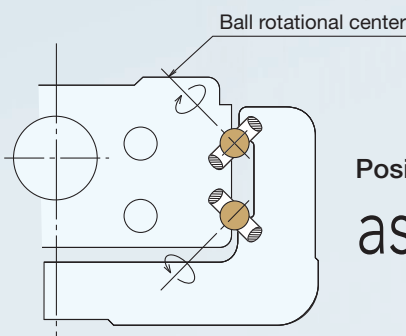

Positioning repeatability

as precise as  $\pm 0.003$  mm!!  
(Precision Grade)

# Modular structure with integrated

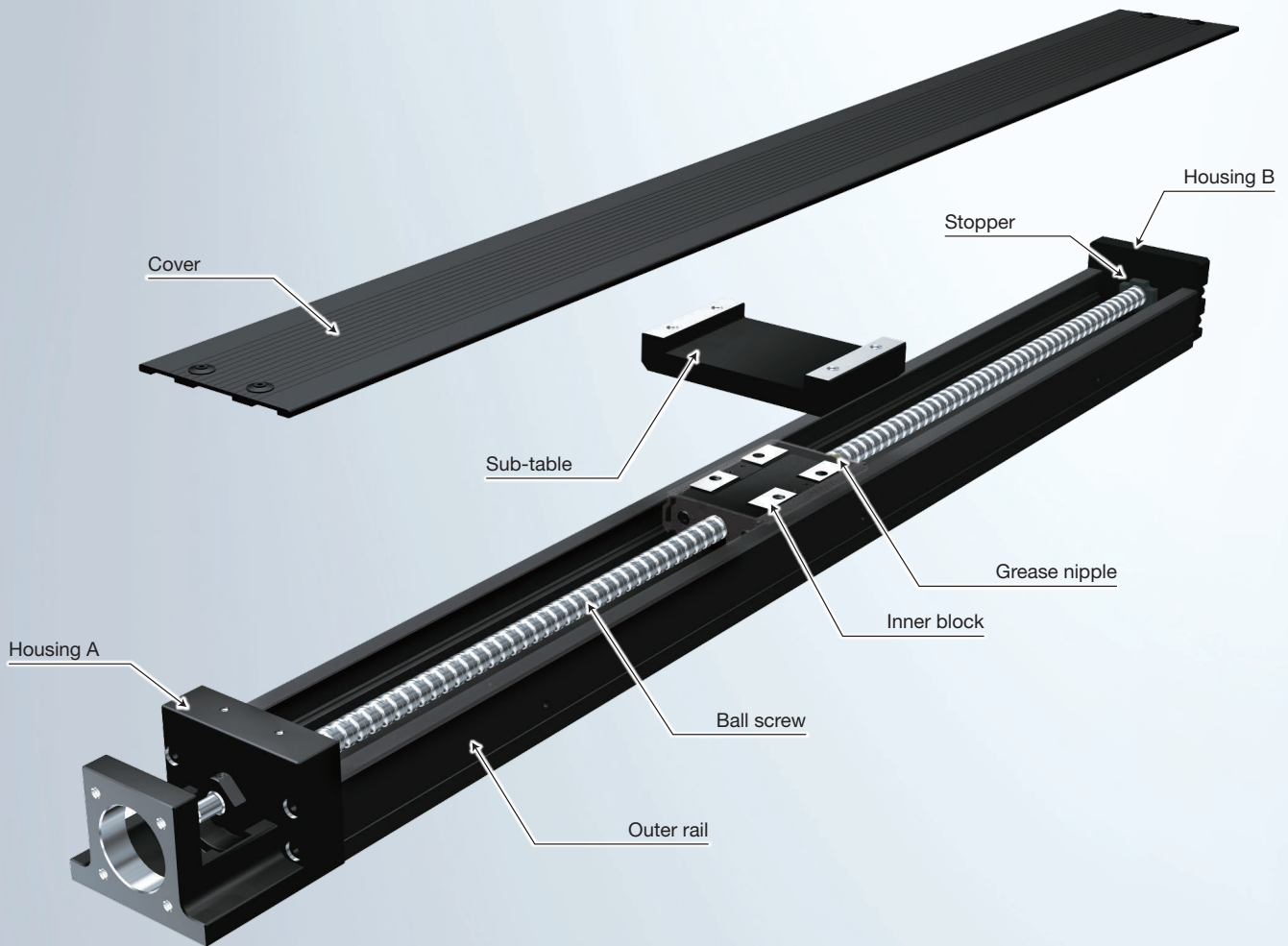

Reduces components by  $\frac{1}{3}$

Adopts a KR modular structure to greatly reduce the number of parts for components using an LM Guide and ball screw. In addition, the time required for procurement work, delivery management, design, and assembly is reduced, resulting in the lead time to complete the equipment being shortened.

## General components

LM Guide	Ball screw
Base	Support bearing (fixed side)
Table	Support bearing (supported side)
Motor bracket	Coupling
Motor	

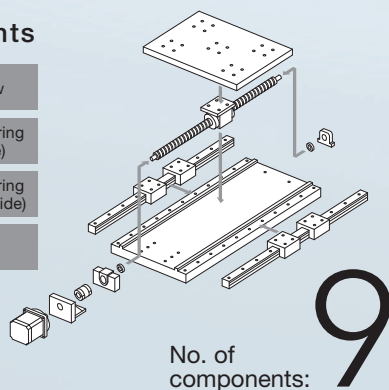

## KR

KR	Coupling
Motor	

No. of components greatly reduced

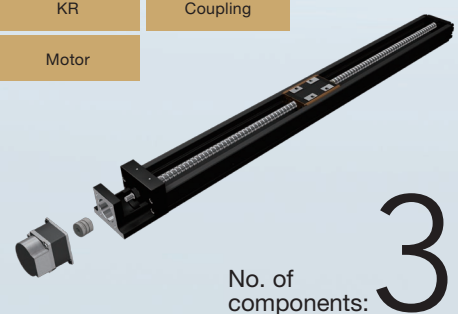

# LM Guide and ball screw

## Select the Optimal Model

A lineup of different shapes and sizes with 4 types of blocks and motor mounting specifications (direct coupling or motor wrap) enables selection to suit the application.

### Size Lineup

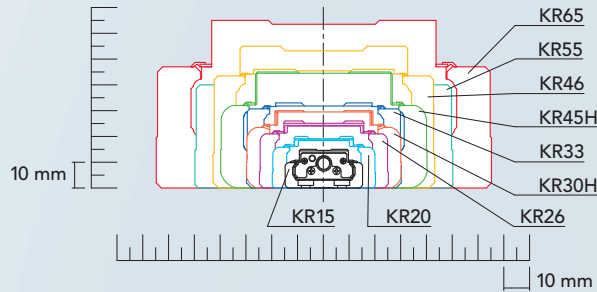

### Block Types

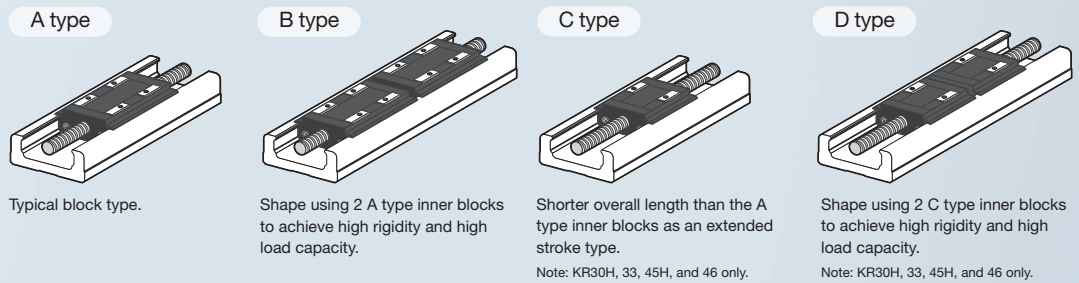

### Shape Lineup



Reduces design time by **Approx. 57%**

Adopts a modular structure to greatly reduce design time when using an LM Guide and ball screw.

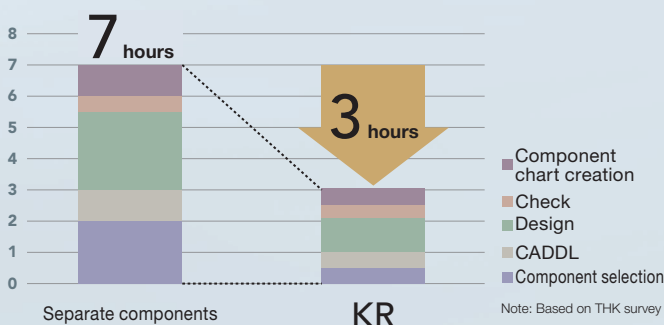

Reduces assembly time by **50%**

Adopts a modular structure to greatly reduce assembly time when using an LM Guide and ball screw.

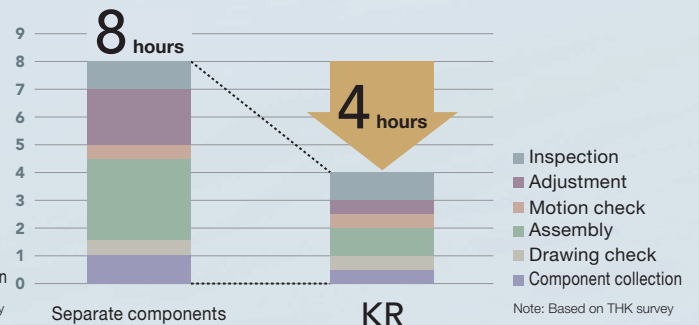



Machine tool industry  
Workpiece Drilling Machine

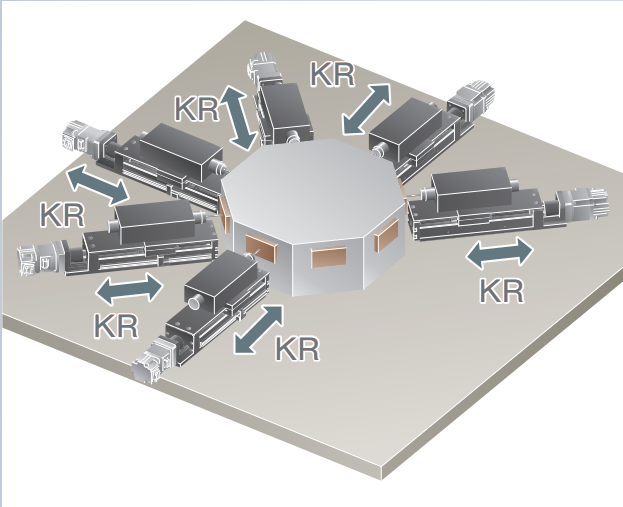

KR is used in workpiece drilling machines. KR's features include its compact form and high rigidity, which allow reduced machinery size while maintaining precision.

Model used KR3306A



Automotive industry  
Processing/Assembly Locater

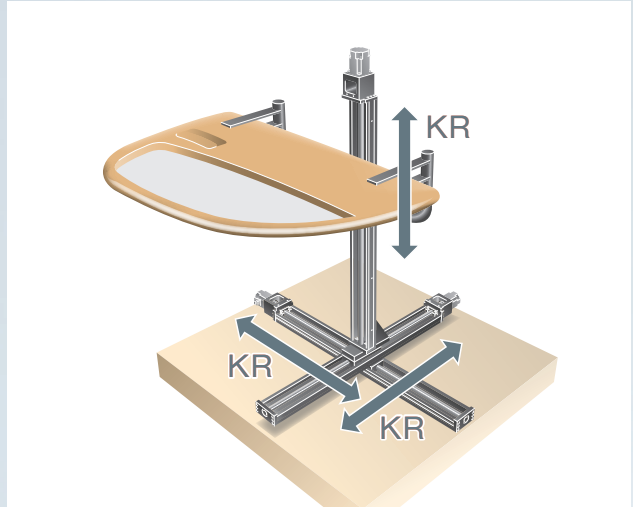

The KR is used for processing and conveying automobile doors. High precision positioning is enabled through the use of KR. KR also provides high rigidity and is able to withstand welding warpage force without an auxiliary guide.

Models used  
X axis: KR6525B  
Y axis: KR5520B  
Z axis: KR4610B

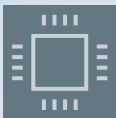

Electronic components industry  
Sealing Equipment

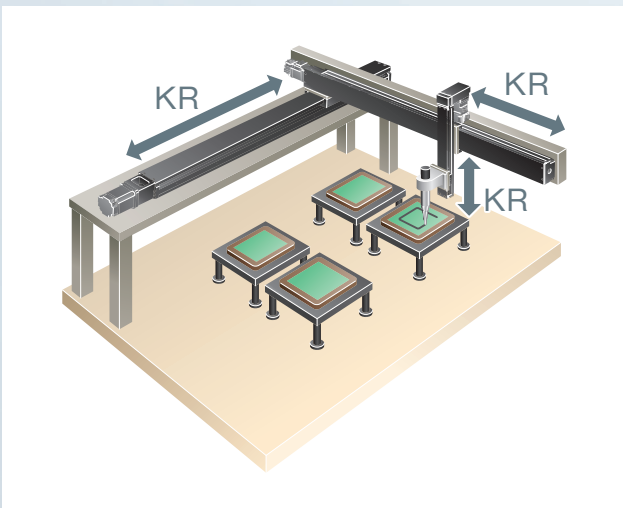

The KR is used for the moving nozzle section of sealing equipment. The KR has excellent rigidity to suppress vibrations at the overhang and nozzle tip, contributing to improved productivity.

Models used  
X axis: KR5520A  
Y axis: KR3310A  
Z axis: KR2006A

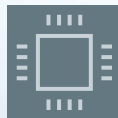

Electronic components industry  
Push Button Inspection Equipment

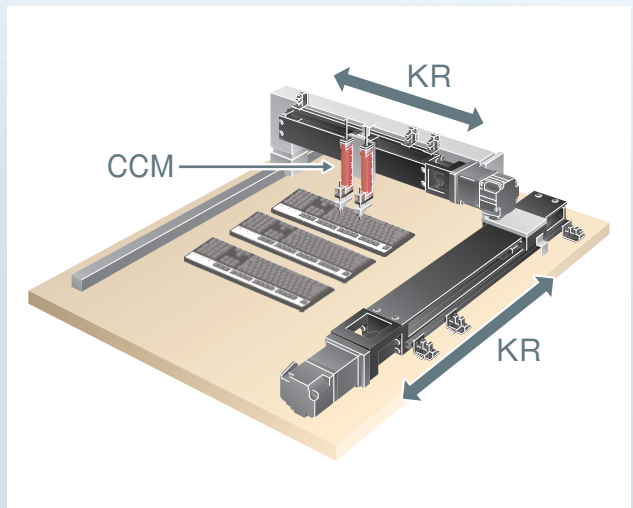

The KR and CCM are used in inspection equipment. Replacing the air cylinder on the Z axis with a linear motor allows for all axes to be motorized, and the high accuracy and high speed provided by the KR enables operations with fast cycle times while offering greater position accuracy.

Models used  
X axis: KR3310A  
Y axis: KR2606A  
Z axis: CCM05



Machine tool industry  
**Pallet Changer**

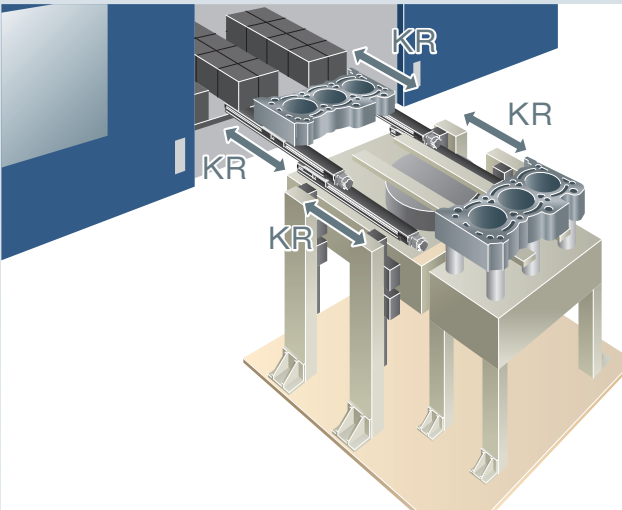

Two 2-block KR's are stacked in the changer. A high rigidity KR unit is used to carry the load of the large overhang. This also takes up less space than conventional multi-jointed robots.

**Models used**

Lower axis: KR4620B  
Upper axis: KR4620B



Machine tool industry  
**Workpiece Inserter**

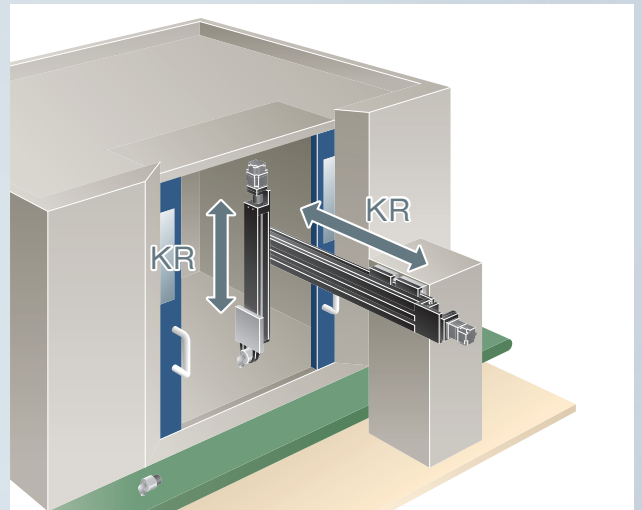

The KR is used in the workpiece inserter axis. The KR outer rail can move to insert items into the opening/closing part. The KR has high rigidity to support large loads.

**Models used**

Horizontal axis: KR4620B  
Lifting axis: KR3310B



General manufacturing  
**Servo Chuck**

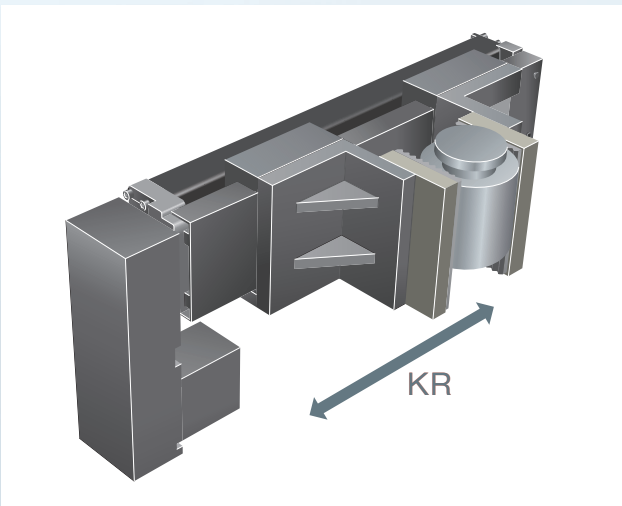

A special KR unit (left/right ball screw specification) is used for the hand chuck that conveys the workpiece. Using a modularized LM Guide and ball screw helps to reduce design/assembly time and achieve even smaller sizes.

**Model used**

Special KR (left/right ball screw specification)



Food industry  
**Strawberry Picking Robot**

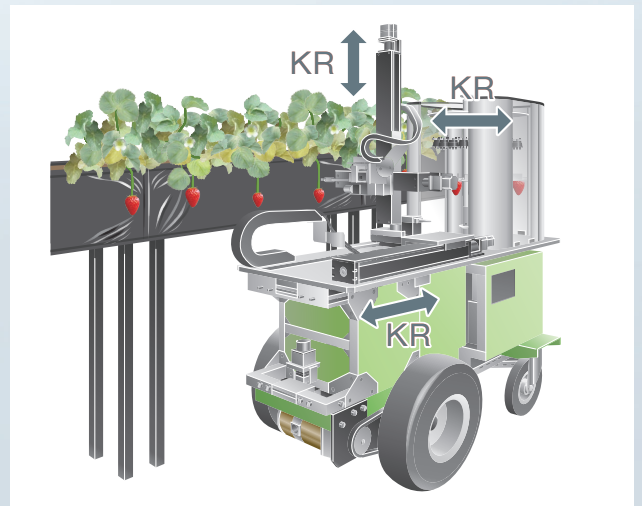

A 3-axis KR combination is used for the light sensor-equipped self-driving robot. A camera is used to measure the ripeness of strawberries and determine which ones to pick. The high-rigidity KR is used to pick ripe strawberries further away from the robot.

**Models used**

X axis: KR4620B  
Y axis: KR3310A  
Z axis: KR4610A

## Series Overview

Model	Ball screw lead (mm)	Stroke <sup>1</sup> (mm)	Estimated motor capacity (W)	Maximum load capacity <sup>2,3</sup> (kg)		
				Horizontal	Wall-mounted	Vertical
KR15	1	25 to 150	-	-	-	-
	2			-	-	-
KR20	1	30 to 130	50	12.5	10	3
	6			12.5	8.5	4
KR26	2	60 to 210	50	27.5	22	9.5
	6			27.5	19	7
KR30H	5	50 to 500	100	35	28	14.5 (14)
	6			35	28	15.5 (12)
	10			28.5	23	9
KR33	5	50 to 600	100	43.5	33	14.5 (14)
	6			43.5	33	15
	10			37.5	25.5	12 (11.5)
KR45H	5	200 to 800	200	65	52	35.5 (18.5)
	10			65	52	18
	20			42 (31)	36.5 (31)	8
	5		400	65	52	35.5 (18.5)
	10			65	52	24.5 (18.5)
	20			59.5	36.5	18
KR46	5	190 to 790	200	77	77	40 (18)
	10			77	64.5	18
	20			43.5 (30.5)	42.5 (30.5)	8
	5		400	96	77	40 (18)
	10			96	64.5	23 (18)
	20			66.5	42.5	18
KR55	20	800 to 1,200	400	68 (67.5)	68 (67.5)	17
	20		750	84	83	33.5
KR65	25	790 to 1,490	750	95	95	24 (16.5)

<sup>1</sup> The stroke is the value with 1 block (A type; without QZ).

<sup>2</sup> The maximum load capacity refers to the mass at the below speed and acceleration/deceleration.

Speed: Rated rotational speed of the motor (3,000 min<sup>-1</sup>)

Acceleration and deceleration rate: Less than 10 mm lead: 0.15 G, 10 mm lead: 0.3 G, 20 mm lead: 0.5 G

<sup>3</sup> The value in parentheses is with motor wrap specifications.

<sup>4</sup> The maximum speed is restricted by the permissible speed of the actuator.

It is also the speed when 1 block (A type; without QZ) and normal accuracy grade are selected.

## Model Number Coding

Model	Ball screw lead	Block type	QZ specification	Stroke
①	②	③	④	⑤
KR46	10	A	QZA	0675
KR15	01: 1 mm	A: x1	No symbol: Without QZ	0020: 20 mm
KR20	02: 2 mm	B: x2	QZ	0030: 30 mm
KR26	05: 5 mm	C: x1	QZA	0035: 35 mm
KR30H	06: 6 mm	D: x2	QZB	0060: 60 mm
KR33	10: 10 mm		QZAD	0080: 80 mm
KR45H	20: 20 mm			0110: 110 mm
KR46	25: 25 mm			0140: 140 mm
KR55				0550: 550 mm
KR65				0590: 590 mm
				to
				1490: 1,490 mm

The available ball screw lead options vary based on the model.

KR15: "01," "02"  
 KR20: "01," "06"  
 KR26: "02," "06"  
 KR30H: "05," "06," "10"  
 KR33: "05," "06," "10"  
 KR45H: "05," "10," "20"  
 KR46: "05," "10," "20"  
 KR55: "20"  
 KR65: "25"

The following models allow selection of ④ QZ specifications.

KR33 → p. 61  
 KR46 → p. 103  
 KR55 → p. 131  
 KR65 → p. 149  
 Notes: 1. For KR33, when selecting 5 mm for the ball screw lead, QZ specification cannot be selected.  
 2. Selection is not possible for KR15, KR20, KR26, KR30H, and KR45H.

If "QZ," "QZA," "QZB," or "QZAD" is selected for ④ QZ specification, specify the stroke with QZ.

KR33 → p. 79 to p. 84  
 KR46 → p. 125 to p. 130  
 KR55 → p. 145 to p. 148  
 KR65 → p. 161 to p. 164

If 2: With bellows is selected for ⑧ Cover, specify the stroke with bellows.  
 → p. 165 to p. 168

	Maximum speed for each stroke <sup>4</sup> (mm/s)																Product page
	Stroke <sup>1</sup> (mm)																
	100	200	300	400	500	600	700	800	900	1,000	1,100	1,200	1,300	1,400	1,500		
75																	p. 11
150																	p. 19
100																	p. 31
600																	p. 43
200																	p. 61
590																	p. 85
	500			330													p. 103
	470			390													p. 131
	790			650													p. 149
	500			330	280	230											
	470			390	330	280											
	790			650	550	470											
		240					230										
		520					430										
		1,050					840										
		240					230										
		520					430										
		1,050					840										
		240					230										
		520					430										
		1,050					850										
		240					230										
		520					430										
		1,050					850										
					800			740	620	530							
					800			740	620	530							
						800							550				

Accuracy grade ⑥	With/without motor ⑦
P	0
<b>No symbol:</b> Normal grade	With direct coupling
<b>H:</b> High accuracy grade	0: Direct coupling (without motor)
<b>P:</b> Precision grade	1: Direct coupling (THK will purchase and mount the motor you specify.)
	With motor wrap
	<b>R1:</b> Non-standard side wrap (without motor)
	<b>R2:</b> Standard side wrap (without motor)
	<b>R3:</b> Bottom side wrap (without motor)
	<b>R4:</b> Non-standard side wrap (THK will purchase and mount the motor you specify.)
	<b>R5:</b> Standard side wrap (THK will purchase and mount the motor you specify.)
	<b>R6:</b> Bottom side wrap (THK will purchase and mount the motor you specify.)

Cover ⑧	Sensors ⑨	Housing A/Intermediate flange ⑩	
1	2	AV	AV
0: Without cover	0	With direct coupling	With motor wrap
1: With cover	1	A0	WN - 05D
2: With bellows	2	AN	WP - 08D
	6	AP	WP - 08K
	7	AQ	WP - 08M
	B	AR	WQ - 08D
	E	AS	WQ - 08K
	H	AT	WQ - 08M
	L	AU	WV - 14M
	J	AV	WY - 11M
	M	AY	WY - 14M
		AZ	WZ - 16M
		A5	WZ - 19M
		A6	W5 - 19M
		10	
		20	
		30	
		40	
		60	

If "0" is selected:  
A coupling is not provided. Indicate when placing an order if a coupling is required.

If "R1," "R2," or "R3" is selected:  
A timing pulley and timing belt are provided.

If "1," "R4," "R5," or "R6" is selected:  
The specified motor will be installed. Indicate the motor cable direction separately.  
Select ⑩ Housing A/Intermediate flange to match the specified motor.

When selecting "QZ,"  
"QZA," "QZB," or "QZAD"  
for ④ QZ specification,  
2: With bellows cannot be selected.

Motors from various manufacturers can be mounted. Contact THK for details.

# KR15 A/B

Direct motor coupling	Motor wrap	Width 30 mm	Height 15 mm	Max. stroke 150 mm
-----------------------	------------	-------------	--------------	--------------------

## Model Number Coding

Model	Ball screw lead	Block type	Stroke	Accuracy grade	With/without motor	Cover	Sensors	Housing A/ Intermediate flange
①	②	③	④	⑤	⑥	⑦	⑧	⑨
KR15	01	A	0025	P	O	1	1	AN
<b>KR15</b>	<b>01: 1 mm</b> <b>02: 2 mm</b>	<b>A: x1</b> <b>B: x2</b>	<b>0025: 25 mm</b> to <b>0150: 150 mm</b>	<b>H: High accuracy grade</b> <b>P: Precision grade</b>	<b>With direct coupling</b> <b>0: Direct coupling (without motor)</b> <b>1: Direct coupling (THK will purchase and mount the motor you specify.)</b> <b>With motor wrap</b> <b>R1: Non-standard side wrap (without motor)</b> <b>R2: Standard side wrap (without motor)</b> <b>R3: Bottom side wrap (without motor)</b> <b>R4: Non-standard side wrap (THK will purchase and mount the motor you specify.)</b> <b>R5: Standard side wrap (THK will purchase and mount the motor you specify.)</b> <b>R6: Bottom side wrap (THK will purchase and mount the motor you specify.)</b>	<b>0: Without cover</b> <b>1: With cover</b> <b>2: With bellows</b>	<b>0</b> <b>1</b> <b>7</b> <b>B</b> <b>E</b>	<b>With direct coupling</b> <b>A0</b> <b>AN</b> <b>AS</b> <b>20</b> <b>With motor wrap</b> <b>WN-05D</b>

When selecting 2: With bellows for ⑦ Cover, specify the stroke with bellows.  
→ p. 165 to p. 166

When selecting "0":  
A coupling is not provided. Indicate when placing an order if a coupling is required.

When selecting "1," "R4," "R5," or "R6":  
The specified motor will be installed. Indicate the motor cable direction separately. Select ⑨ Intermediate flange to match the specified motor.

### ③ Block Type

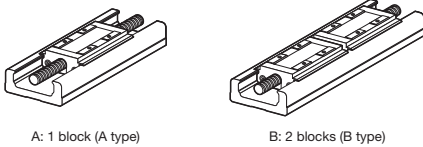

### ⑥ Motor Mounting Method

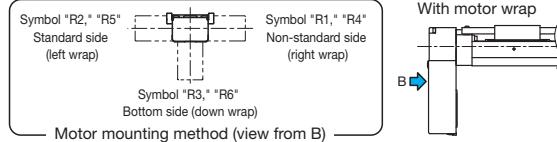

## Selection Information

### Basic Specifications

LM Guide	Basic dynamic load rating C (N)		2,050
	Basic static load rating C <sub>0</sub> (N)		3,290
	Radial clearance (mm)	High accuracy grade (H)	-0.001 to +0.002
		Precision grade (P)	-0.005 to -0.002
	Geometric moment of inertia	I <sub>x</sub> <sup>1</sup> (mm <sup>4</sup> )	9.08×10 <sup>2</sup>
I <sub>y</sub> <sup>2</sup> (mm <sup>4</sup> )		1.42×10 <sup>4</sup>	
Mass (kg/m)		1.04	
Ball screw	Ball screw lead (mm)		1   2
	Basic dynamic load rating C <sub>a</sub> (N)	High accuracy grade (H)	340
		Precision grade (P)	230
	Basic static load rating C <sub>0a</sub> (N)	High accuracy grade (H)	660
		Precision grade (P)	410
	Screw shaft diameter (mm)		Ø5
	Thread minor diameter (mm)		Ø4.5
Ball center-to-center diameter (mm)		Ø5.15	
Permissible rotational speed <sup>3</sup> (min <sup>-1</sup> )	High accuracy grade (H)	4,500	
	Precision grade (P)	4,500	
Bearing unit (fixed side)	Axial direction	Basic dynamic load rating C <sub>a</sub> (N)	590
		Static permissible load P <sub>0a</sub> (N)	290
Permissible input torque (N·m)	Direct coupling	0.05	
	Motor wrap	0.10	
Static permissible moment <sup>4,5</sup> (N·m)		M <sub>A</sub> : 12.1 (70.3), M <sub>C</sub> : 12.1 (70.3), M <sub>B</sub> : 38 (76)	
Standard grease		THK AFF Grease	

<sup>1</sup> I<sub>x</sub> is the geometric moment of inertia about the X axis.

<sup>2</sup> I<sub>y</sub> is the geometric moment of inertia about the Y axis.

<sup>3</sup> The permissible rotational speed may decrease as the stroke becomes longer.

<sup>4</sup> The value in parentheses is with 2 blocks (B type) attached.

<sup>5</sup> See p. 172 for the values if "1" or "2" is selected for item ⑦ in the Model Number Coding.

Note 1: LM Guide load rating is the load rating per block.

### Accuracy

Accuracy grade	Item	Stroke <sup>6</sup>					
		25	50	75	100	125	150
High accuracy grade (H)	Positioning repeatability (mm)	±0.004					
	Positioning accuracy (mm)	0.04					
	Running parallelism (vertical direction) (mm)	0.02					
	Backlash (mm)	0.01					
	Starting torque (N·cm)	0.4					

Accuracy grade	Item	Stroke <sup>6</sup>					
		25	50	75	100	125	150
Precision grade (P)	Positioning repeatability (mm)	±0.003					
	Positioning accuracy (mm)	0.02					
	Running parallelism (vertical direction) (mm)	0.01					
	Backlash (mm)	0.002					
	Starting torque (N·cm)	0.8					

<sup>6</sup> Stroke with 1 block (A type).

Notes: 2. Precision evaluation in accordance with THK standards.

3. Measured using a motor for inspection. With motor wrap specifications, measurements are not made in the completed motor wrap state.

4. The starting torque represents the value when containing THK AFF Grease.

5. The starting torque may exceed standards if using vacuum grease, clean room grease, or other high-viscosity greases, so care should be taken when selecting a motor.

6. Contact THK for accuracy higher than the standard stroke.

### Geometric Moment of Inertia

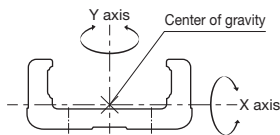

### Static Permissible Moment

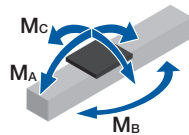

## Motor Selection Information

Stroke <sup>1</sup> (mm)	Outer rail length (mm)	LM Guide				Sliding resistance value <sup>2</sup> (N)	Ball screw		Motor mounting part	
		Moving part mass (kg)			Lead (mm)		Shaft length (mm)	Direct coupling	Motor wrap	
		Block mass	Sub-table mass	Total mass				Shaft end diameter (mm)	Timing pulley (sum of two) Inertial moment $\times 10^{-4}$ (kg·m <sup>2</sup> )	
25 to 150	75 to 200	A type: 0.04 B type: 0.08	A type: 0.03 B type: 0.06	A type: 0.07 B type: 0.14	0.9	1, 2	106 to 231	Ø3h6	0.004	

<sup>1</sup> Stroke with 1 block (A type).

<sup>2</sup> Value with 1 block (A type). This value is the sum of the rolling resistance value and seal resistance value.

Note: Refer to p. 16 for applicable couplings.

With Cover/Without Cover  
Direct Motor Coupling

Dimensions

With Cover

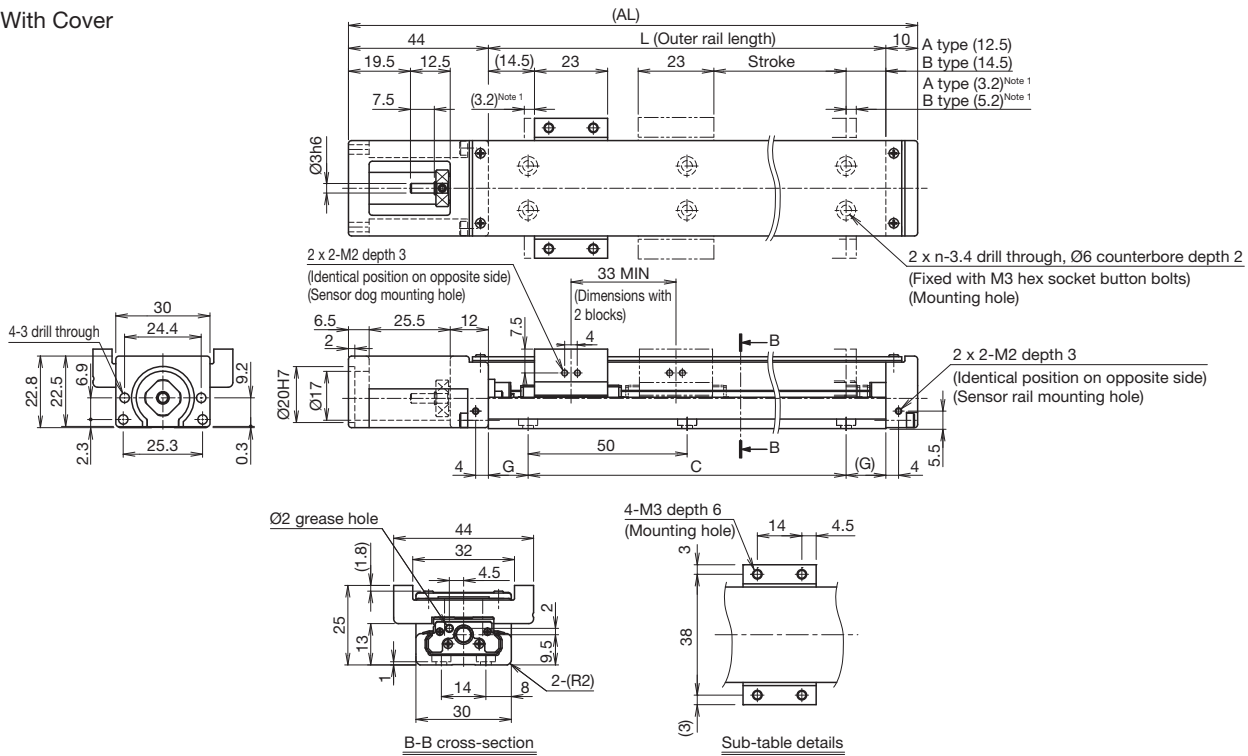

Without Cover

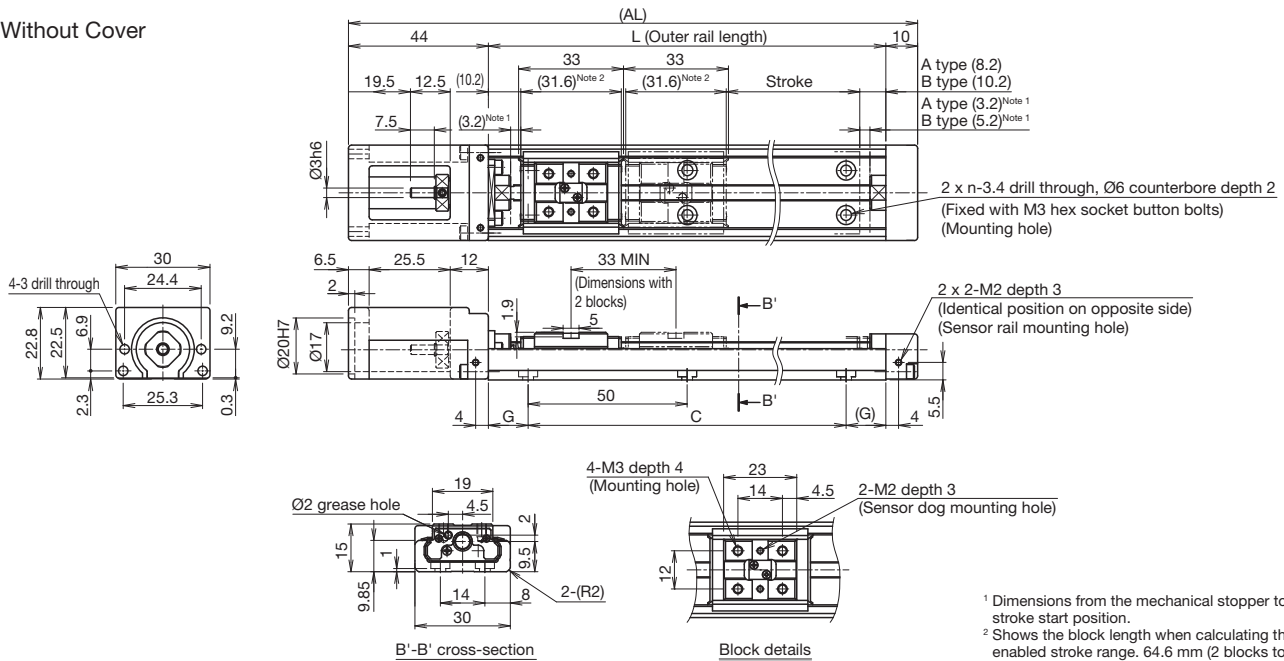

<sup>1</sup> Dimensions from the mechanical stopper to the stroke start position.

<sup>2</sup> Shows the block length when calculating the enabled stroke range. 64.6 mm (2 blocks total) for KR15 with 2 blocks (B type).

Stroke (mm) (Stroke between mechanical stoppers)	A type	25 (31.4)	50 (56.4)	75 (81.4)	100 (106.4)	125 (131.4)	150 (156.4)
	B type <sup>3</sup>	-	-	40 (48.4)	65 (73.4)	90 (98.4)	115 (123.4)
Maximum speed <sup>4</sup> (mm/s)	Ball screw lead: 1 mm	75					
	Ball screw lead: 2 mm	150					
Dimensions (mm)	AL	129	154	179	204	229	254
	L	75	100	125	150	175	200
	C	50	50	100	100	150	150
	G	12.5	25	12.5	25	12.5	25
No. of mounting holes	n	2	2	3	3	4	4
Mass <sup>5, 6</sup> (kg)		0.25 (0.2)	0.28 (0.23)	0.32 (0.26)	0.35 (0.29)	0.38 (0.32)	0.41 (0.35)

<sup>3</sup> The value with 2 blocks (B type) attached.

<sup>4</sup> The maximum speed is restricted by the actuator's permissible speed.

<sup>5</sup> The mass with 2 blocks (B type) has 0.07 kg (with cover) or 0.04 kg added.

<sup>6</sup> Parentheses show the values without cover.

With Cover/Without Cover  
Motor Wrap

**Dimensions**

With Cover

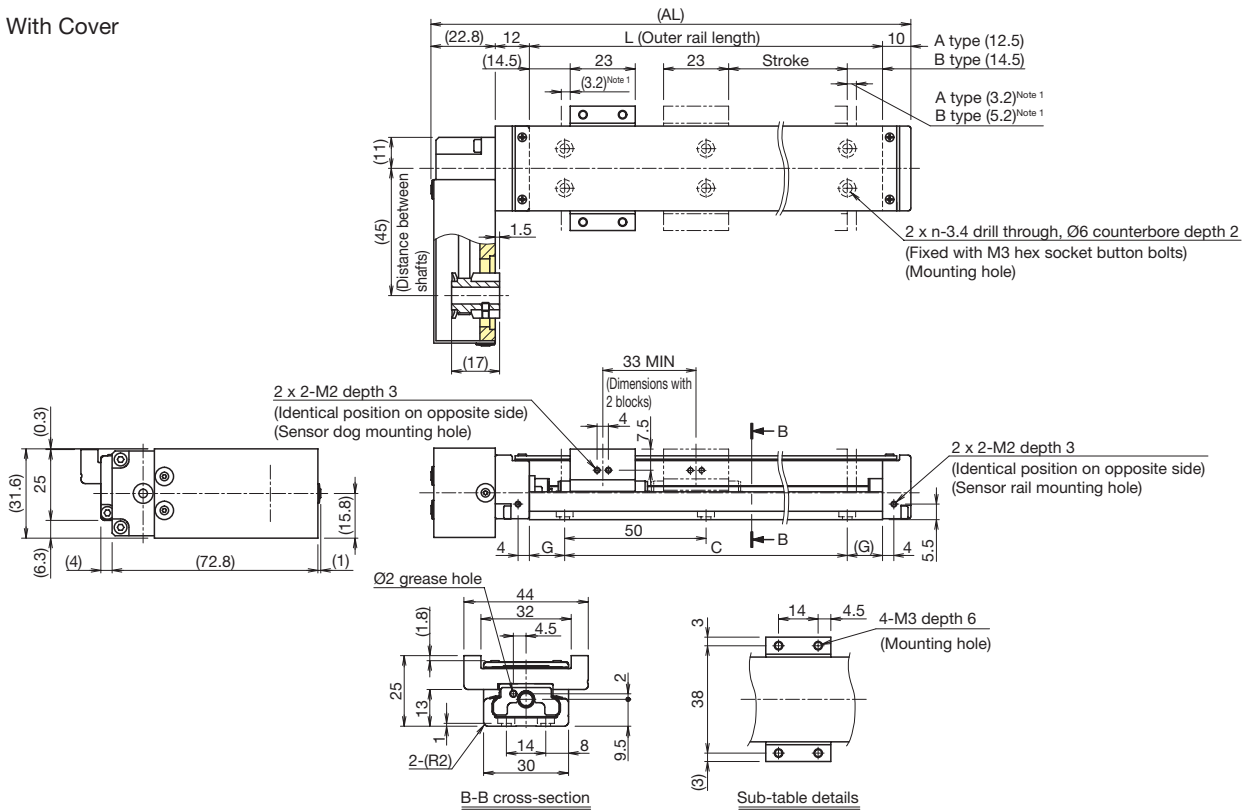

Without Cover

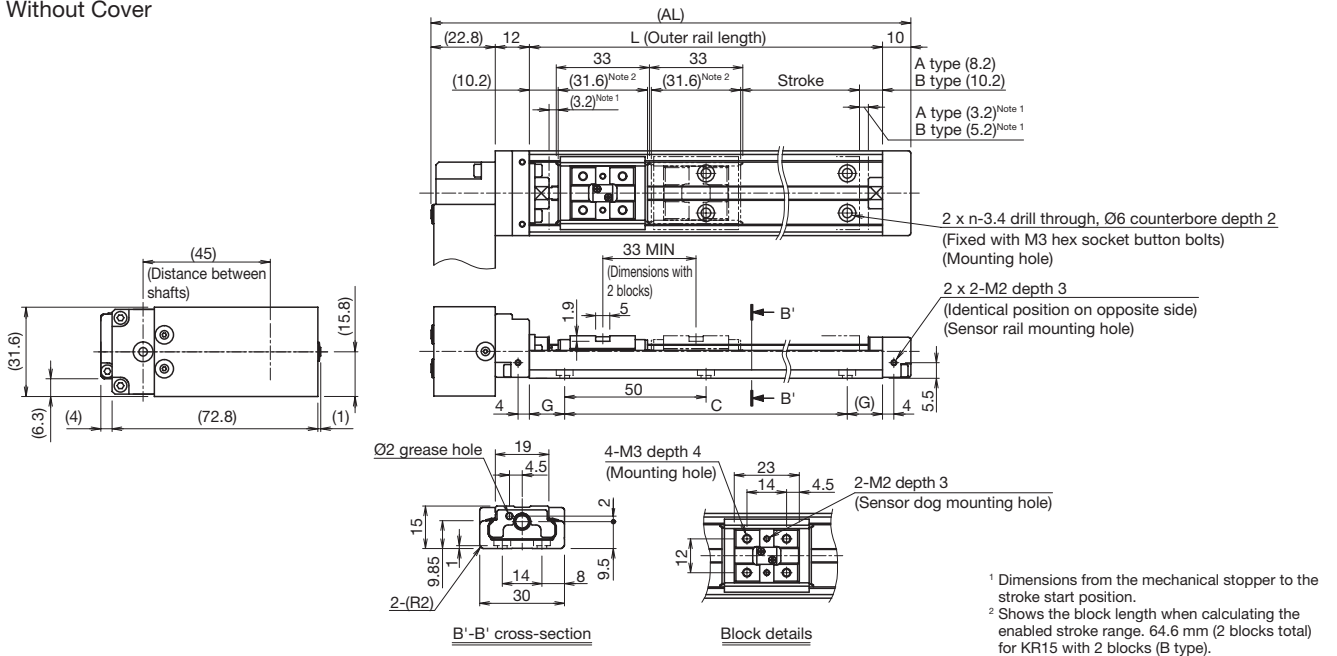

<sup>1</sup> Dimensions from the mechanical stopper to the stroke start position.  
<sup>2</sup> Shows the block length when calculating the enabled stroke range. 64.6 mm (2 blocks total) for KR15 with 2 blocks (B type).

Stroke (mm) (Stroke between mechanical stoppers)	A type	25 (31.4)	50 (56.4)	75 (81.4)	100 (106.4)	125 (131.4)	150 (156.4)
	B type <sup>3</sup>	-	-	40 (48.4)	65 (73.4)	90 (98.4)	115 (123.4)
Maximum speed <sup>4</sup> (mm/s)	Ball screw lead: 1 mm	75					
	Ball screw lead: 2 mm	150					
Dimensions (mm)	AL	119.8	144.8	169.8	194.8	219.8	244.8
	L	75	100	125	150	175	200
	C	50	50	100	100	150	150
	G	12.5	25	12.5	25	12.5	25
No. of mounting holes	n	2	2	3	3	4	4
Mass <sup>5,6</sup> (kg)		0.43 (0.38)	0.46 (0.41)	0.49 (0.44)	0.53 (0.47)	0.56 (0.5)	0.59 (0.53)

<sup>3</sup> The value with 2 blocks (B type) attached.  
<sup>4</sup> The maximum speed is restricted by the actuator's permissible speed.  
<sup>5</sup> The mass with 2 blocks (B type) has 0.07 kg (with cover) or 0.04 kg added.  
<sup>6</sup> Parentheses show the values without cover.

# Options

## Sensors

Optional proximity sensors are available. Sensor-equipped models also feature a dedicated sensor rail and sensor dog. Sensors, sensor rails, and sensor dogs can be mounted on both sides when the stroke is less than 70 mm.

Mounting example

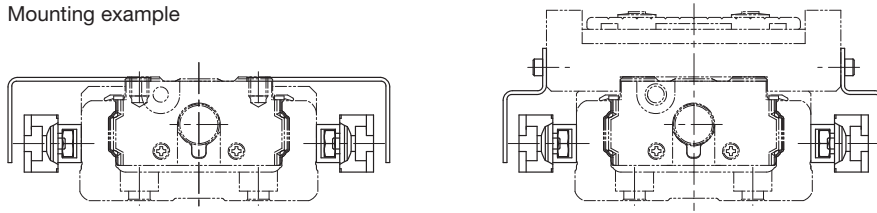

Symbol	Description	Model	Accessories
0	None	-	-
1	With sensor rail	-	Mounting screws, sensor rail (x1 or 2)
7	Proximity sensor N.O. contact <sup>1</sup> (x3)	APM-D3A1-001 (Azbil Corporation)	Mounting screws, nuts, sensor dog (x1 or 2), sensor rail (x1 or 2)
B	Proximity sensor N.C. contact <sup>2</sup> (x3)	APM-D3B1-003 (Azbil Corporation)	Mounting screws, nuts, sensor dog (x1 or 2), sensor rail (x1 or 2)
E	Proximity sensor N.O. contact <sup>1</sup> (x1) N.C. contact <sup>2</sup> (x2)	APM-D3A1-001 (Azbil Corporation) APM-D3B1-003 (Azbil Corporation)	Mounting screws, nuts, sensor dog, sensor rail (x1 or 2)

<sup>1</sup> N.O. contact: Normally open contact point  
<sup>2</sup> N.C. contact: Normally closed contact point

Notes: 1. If proximity sensors are close to one another, they may not function properly. If that happens, please prepare a type with a different frequency.  
 2. Mounting of sensors other than those in the table above is possible. Contact THK for details.

## Sensor Rail Mounting Dimensions

Mounting only a sensor rail is also possible.

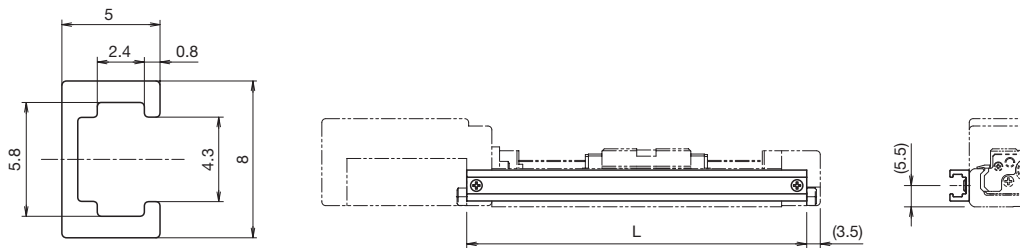

Sensor rail details

Stroke <sup>3</sup> (mm)	Outer rail length (mm)	L (mm)
25	75	88
50	100	113
75	125	138
100	150	163
125	175	188
150	200	213

<sup>3</sup> Stroke with 1 block (A type).

## Proximity Sensor Mounting Dimensions

Without cover

With cover

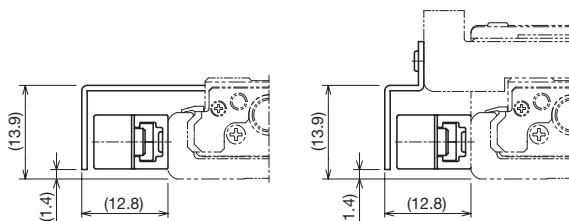

Symbol	Model	Manufacturer
7, B, E	APM-D3A1-001	Azbil Corporation
	APM-D3B1-003	

Sensor dog width (without cover): 5 mm  
 Sensor dog width (with cover): 8 mm

## Intermediate Flange (Direct Coupling)

Several types of intermediate flanges for mounting motors are available.

When selecting "0" or "1" for Model Number Coding ⑥ With/without motor, specify an intermediate flange that matches the motor used.

Compatibility Table: Motors Used, Intermediate Flanges, and Couplings

Motor type	Manufacturer	Series	Motor model	Motor rated output (W)	Flange size	Housing A/ Intermediate flange	Compatible coupling models		
							MIKI PULLEY CO., LTD.	Nabeya Bi-tech Kaisha (NBK)	
AC servo motor	YASKAWA Electric Corporation	Σ-Vmini	SGMMV-A1	10	25×25	AN	SFC-005DA2-3B-5B	XGT2-15C-3-5	
			SGMMV-A2	20					
			SGMMV-A3	30					
	Mitsubishi Electric Corporation	MELSERIO	J4	HG-AK0136	10	25×25	AN	SFC-005DA2-3B-5B	XGT2-15C-3-5
				HG-AK0236	20				
			HG-AK0336	30					

Motor type	Manufacturer	Series	Motor model	Flange size	Housing A/ Intermediate flange	Compatible coupling models	
						MIKI PULLEY CO., LTD.	Nabeya Bi-tech Kaisha (NBK)
Stepper motor	ORIENTAL MOTOR CO., LTD.	α step	AZ2*, AR2*	28×28	AS	SFC-005DA2-3B-5B-L26	XGT2-15C-3-5
			5-phase CRK				
		5-phase PKP	PKP52*				
		2-phase PKP/CVD	PKP22*				
	KEYENCE CORPORATION	2-phase	QS-M28	28×28	AS	SFC-005DA2-3B-5B-L26	XGT2-15C-3-5
	SANYO DENKI CO., LTD.	PB	PBDM28*	28×28	AS	SFC-005DA2-3B-5B	XGT2-15C-3-5
		5-phase	FAF/DF52*				
2-phase		D*14S28*					

Notes: 1. The table shows only a portion of the model numbers for motors. For details regarding model numbers, please see the catalog for each respective motor manufacturer.  
 2. If the maximum torque for motors exceeds the permissible input torque (p. 11), please consider a safety measure to limit the torque.  
 3. When installing a motor other than the motor model numbers listed above, contact THK.

### Housing A

KR15
A0

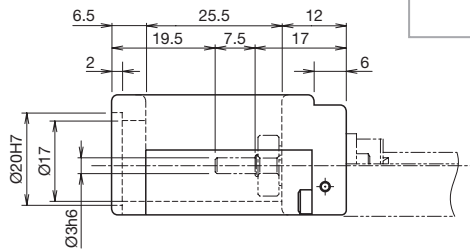
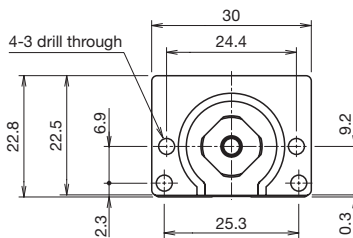

### Intermediate Flange

KR15
AN

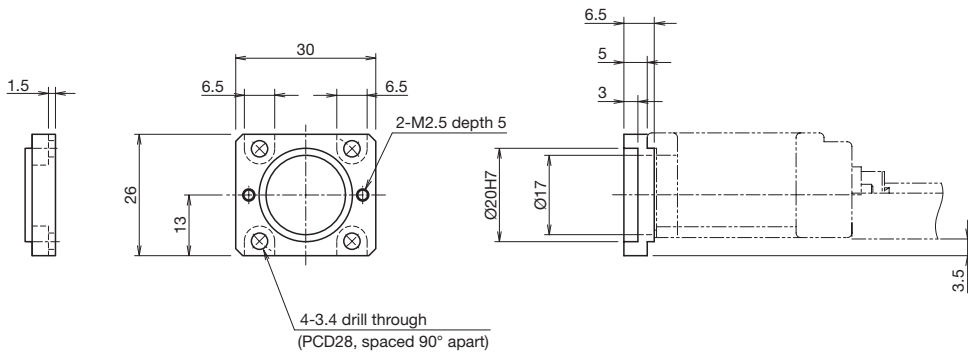

KR15
AS

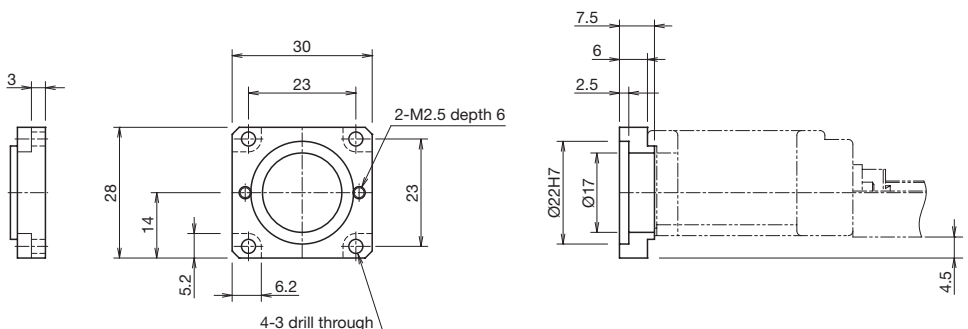

# Options

## Intermediate Flange (Motor Wrap)

Several types of intermediate flanges for mounting motors are available.

When selecting "R1," "R2," "R3," "R4," "R5," or "R6" for Model Number Coding ⑥ With/without motor, specify an intermediate flange that matches the motor used.

### Symbol Coding

Motor wrap symbol ①	Intermediate flange ②	Motor shaft diameter (mm) ③	Motor shaft securing method ④
W	N	05	D
W	Refer to the Compatibility Table: Motors Used and Motor Wrap Symbols below.	Specify a motor shaft diameter. (Refer to the Compatibility Table: Motors Used and Motor Wrap Symbols below.)	D: D-cut

### Motor Shaft Securing Method

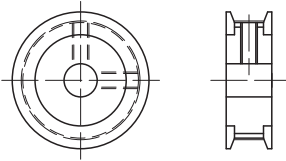

D-cut

### Compatibility Table: Motors Used and Motor Wrap Symbols

Motor type	Manufacturer	Series	Motor model	Motor rated output (W)	Flange size	Housing A/Intermediate flange
AC servo motor	YASKAWA Electric Corporation	Σ-Vmini	SGMMV-A1	10	25×25	WN-05D
			SGMMV-A2	20		
			SGMMV-A3	30		
	Mitsubishi Electric Corporation	MELSERVO J4	HG-AK0136	10	25×25	WN-05D
			HG-AK0236	20		
			HG-AK0336	30		

Notes: 1. The table shows only a portion of the model numbers for motors. For details regarding model numbers, please see the catalog for each respective motor manufacturer.  
 2. If the maximum torque for motors exceeds the permissible input torque (p. 11), please consider a safety measure to limit the torque.  
 3. When installing a motor other than the motor model numbers listed above, contact THK.

Motor Wrap Housing A

KR15
20

KR**	Actuator model
●◇	●: Housing A ◇: Intermediate flange

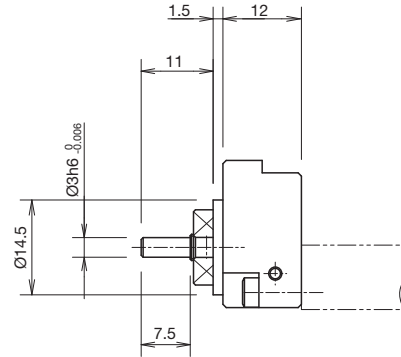
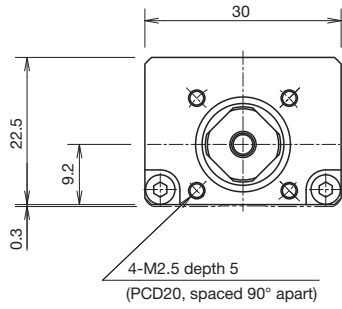

Note: The shaft end must be considered separately with motor wrap types. Contact THK for details.

Motor Wrap Specification (Intermediate Flange)

KR15
WN

KR**	Actuator model
W□	□: Intermediate flange

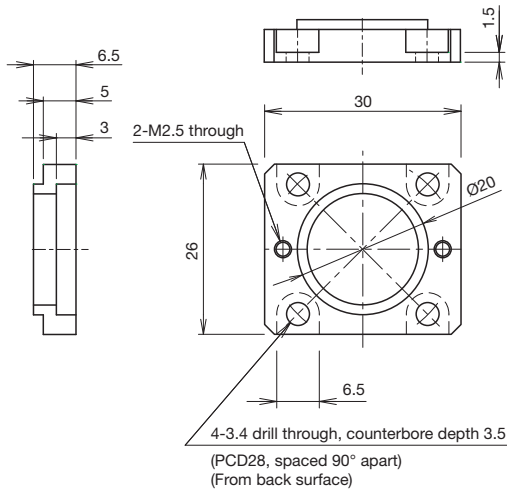

# KR20 A/B

Direct motor coupling

Motor wrap

Width 40 mm

Height 20 mm

Max. stroke 130 mm

## Model Number Coding

Model	Ball screw lead	Block type	Stroke	Accuracy grade	With/without motor	Cover	Sensors	Housing A/ Intermediate flange
①	②	③	④	⑤	⑥	⑦	⑧	⑨
KR20	01	A	0030	P	0	1	2	AQ
<b>KR20</b>	<b>01: 1 mm</b> <b>06: 6 mm</b>	<b>A: x1</b> <b>B: x2</b>	<b>0030: 30 mm</b> to <b>0130: 130 mm</b>	<b>No symbol:</b> Normal grade <b>H:</b> High accuracy grade <b>P:</b> Precision grade	<b>0:</b> With direct coupling <b>1:</b> Direct coupling (THK will purchase and mount the motor you specify.) <b>With motor wrap</b> <b>R1:</b> Non-standard side wrap (without motor) <b>R2:</b> Standard side wrap (without motor) <b>R3:</b> Bottom side wrap (without motor) <b>R4:</b> Non-standard side wrap (THK will purchase and mount the motor you specify.) <b>R5:</b> Standard side wrap (THK will purchase and mount the motor you specify.) <b>R6:</b> Bottom side wrap (THK will purchase and mount the motor you specify.)	<b>0:</b> Without cover <b>1:</b> With cover <b>2:</b> With bellows	<b>0</b> <b>1</b> <b>2</b> <b>6</b> <b>7</b> <b>B</b> <b>E</b> <b>H</b> <b>L</b> <b>J</b> <b>M</b>	<b>With direct coupling</b> <b>A0</b> <b>AN</b> <b>AP</b> <b>AQ</b> <b>AR</b> <b>AS</b> <b>20</b> <b>With motor wrap</b> <b>WN-05D</b> <b>WP-08D</b> <b>WP-08K</b> <b>WQ-08D</b> <b>WQ-08K</b>
			When selecting 2: With bellows for ⑦ Cover, specify the stroke with bellows. → p. 165 to p. 166		When selecting "0": A coupling is not provided. Indicate when placing an order if a coupling is required.		Sensor details → p. 25	
			When selecting "1," "R4," "R5," or "R6": The specified motor will be installed. Indicate the motor cable direction separately. Select ⑨ Intermediate flange to match the specified motor.				With direct coupling → p. 27 With motor wrap → p. 29	

### ③ Block Type

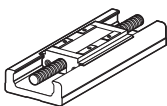

A: 1 block (A type)

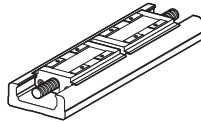

B: 2 blocks (B type)

### ⑥ Motor Mounting Method

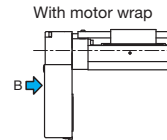
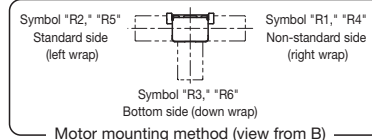

## Selection Information

### Basic Specifications

LM Guide	Basic dynamic load rating C (N)		4,290
	Basic static load rating C <sub>0</sub> (N)		7,340
	Radial clearance (mm)	Normal grade/High accuracy grade (H)	-0.003 to +0.002
		Precision grade (P)	-0.007 to -0.003
Geometric moment of inertia	I <sub>x</sub> <sup>1</sup> (mm <sup>4</sup> )	6.1 × 10 <sup>5</sup>	
	I <sub>y</sub> <sup>2</sup> (mm <sup>4</sup> )	6.2 × 10 <sup>4</sup>	
	Mass (kg/m)	2.6	
Ball screw	Ball screw lead (mm)		1      6
	Basic dynamic load rating C <sub>a</sub> (N)	Normal grade/High accuracy grade (H)	660      860
		Precision grade (P)	1,060
	Basic static load rating C <sub>0a</sub> (N)	Normal grade/High accuracy grade (H)	1,170      1,450
		Precision grade (P)	1,600
	Screw shaft diameter (mm)		Ø6
	Thread minor diameter (mm)		Ø5.3      Ø5
Ball center-to-center diameter (mm)		Ø6.15      Ø6.3	
Permissible rotational speed <sup>3</sup> (min <sup>-1</sup> )	Normal grade/High accuracy grade (H)	6,000	
	Precision grade (P)		
Bearing unit (fixed side)	Axial direction	Basic dynamic load rating C <sub>a</sub> (N)	1,000
		Static permissible load P <sub>0a</sub> (N)	1,240
Permissible input torque (N·m)	Direct coupling	0.20	0.40
	Motor wrap		
Static permissible moment <sup>4,5</sup> (N·m)		M <sub>A</sub> : 31 (176), M <sub>B</sub> : 31 (176), M <sub>C</sub> : 83 (165)	
Service life <sup>6</sup> (km)		3,000	5,000
Standard grease/Grease nipple used		THK AFA Grease/PB107	

<sup>1</sup> I<sub>x</sub> is the geometric moment of inertia about the X axis.

<sup>2</sup> I<sub>y</sub> is the geometric moment of inertia about the Y axis.

<sup>3</sup> The permissible rotational speed may decrease as the stroke becomes longer.

<sup>4</sup> The value in parentheses is with 2 blocks (B type) attached.

<sup>5</sup> See p. 172 for the values if "1" or "2" is selected for item ⑦ in the Model Number Coding.

<sup>6</sup> Calculated under the following conditions.

Stroke: 80 mm (A type), 85 mm (B type) / Speed: 50 mm/s (for 1 mm lead), 300 mm/s (for 6 mm lead) / Load mass: Maximum load capacity (p. 9) / Acceleration/deceleration: As when set to maximum load capacity (p. 9) / Center of gravity: Center of the table's upper surface.

Note 1: LM Guide load rating is the load rating per block.

### Accuracy

Accuracy grade	Item	Stroke <sup>7</sup>		
		30	80	130
Normal grade (no symbol)	Positioning repeatability (mm)	±0.01		
	Positioning accuracy (mm)	Not specified		
	Running parallelism (vertical direction) (mm)	Not specified		
	Backlash (mm)	0.015		
	Starting torque (N·cm)	0.5		

Accuracy grade	Item	Stroke <sup>7</sup>		
		30	80	130
High accuracy grade (H)	Positioning repeatability (mm)	±0.004		
	Positioning accuracy (mm)	0.06		
	Running parallelism (vertical direction) (mm)	0.025		
	Backlash (mm)	0.01		
	Starting torque (N·cm)	0.5		

Accuracy grade	Item	Stroke <sup>7</sup>		
		30	80	130
Precision grade (P)	Positioning repeatability (mm)	±0.003		
	Positioning accuracy (mm)	0.02		
	Running parallelism (vertical direction) (mm)	0.01		
	Backlash (mm)	0.003		
	Starting torque (N·cm)	1.2		

<sup>7</sup> Stroke with 1 block (A type).

Notes: 2. Precision evaluation in accordance with THK standards.

3. Measured using a motor for inspection. With motor wrap specifications, measurements are not made in the completed motor wrap state.

4. The starting torque represents the value when containing THK AFA Grease.

5. The starting torque may exceed standards if using vacuum grease, clean room grease, or other high-viscosity greases, so care should be taken when selecting a motor.

6. Contact THK for accuracy higher than the standard stroke.

### Geometric Moment of Inertia

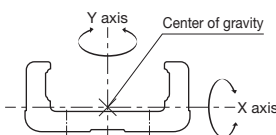

### Static Permissible Moment

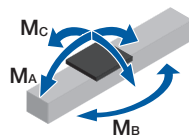

### Motor Selection Information

Stroke <sup>1</sup> (mm)	Outer rail length (mm)	LM Guide				Ball screw		Motor mounting part	
		Moving part mass (kg)			Sliding resistance value <sup>2</sup> (N)	Lead (mm)	Shaft length (mm)	Direct coupling	Motor wrap
		Block mass	Sub-table mass	Total mass				Shaft end diameter (mm)	Timing pulley (sum of two) Inertial moment x 10 <sup>-4</sup> (kg·m <sup>2</sup> )
30 to 130	100 to 200	A type: 0.08 B type: 0.16	A type: 0.05 B type: 0.1	A type: 0.13 B type: 0.26	1.2	1, 6	133 to 233	Ø4h7	0.013

<sup>1</sup> Stroke with 1 block (A type).

<sup>2</sup> Value with 1 block (A type). This value is the sum of the rolling resistance value and seal resistance value.

Note: Refer to p. 27 for applicable couplings.

### Permissible Overhang Length<sup>3</sup>

Horizontal

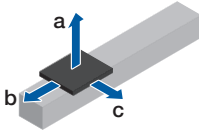

Wall-Mounted

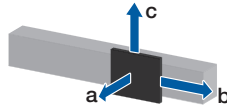

Vertical

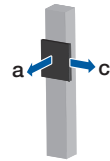

Estimated motor capacity 50 W	Ball screw lead (mm)	Load mass (kg)	a	b	c	
			(mm)	(mm)	(mm)	
Direct coupling	A type	1	3	350	90	160
			6	160	40	80
			12.5	70	20	40
		6	3	350	80	160
			6	160	30	80
			12.5	70	10	40
	B type	1	4	400	370	250
			8.5	400	170	110
			17.5	260	80	50
		6	4	400	340	250
			8.5	400	160	110
			17.5	260	70	50

Estimated motor capacity 50 W	Ball screw lead (mm)	Load mass (kg)	a	b	c	
			(mm)	(mm)	(mm)	
Direct coupling	A type	1	2.5	170	110	360
			5	70	50	180
			10	20	20	90
		6	2	220	120	400
			4	100	50	220
			8	40	20	110
	B type	1	3.5	260	300	400
			7	120	150	400
			14	50	70	250
		6	3.5	260	300	400
			7	120	150	400
			14	50	70	250

Estimated motor capacity 50 W	Ball screw lead (mm)	Load mass (kg)	a	c	
			(mm)	(mm)	
Direct coupling	A type	1	0.5	400	400
			1.5	150	140
			3	60	70
		6	1	240	210
			2	110	100
			4	40	40
	B type	1	0.5	400	400
			1.5	400	400
			3.5	310	230
		6	1.5	400	400
			3.5	310	230
			7	140	110

<sup>3</sup> This is the value with the service life of the LM Guide limited to 5,000 km (3,000 km for 1 mm lead only). The calculation conditions are as follows.  
Stroke: 80 mm (A type), 60 mm (B type) / Acceleration/deceleration: 0.3 G / Speed: 50 mm/s (for 1 mm lead), 300 mm/s (for 6 mm lead) / Overhang direction: Loaded only in a single direction.  
Dimensions a, b, and c are from the center of the table's upper surface.

With Cover  
Direct Motor Coupling

Dimensions

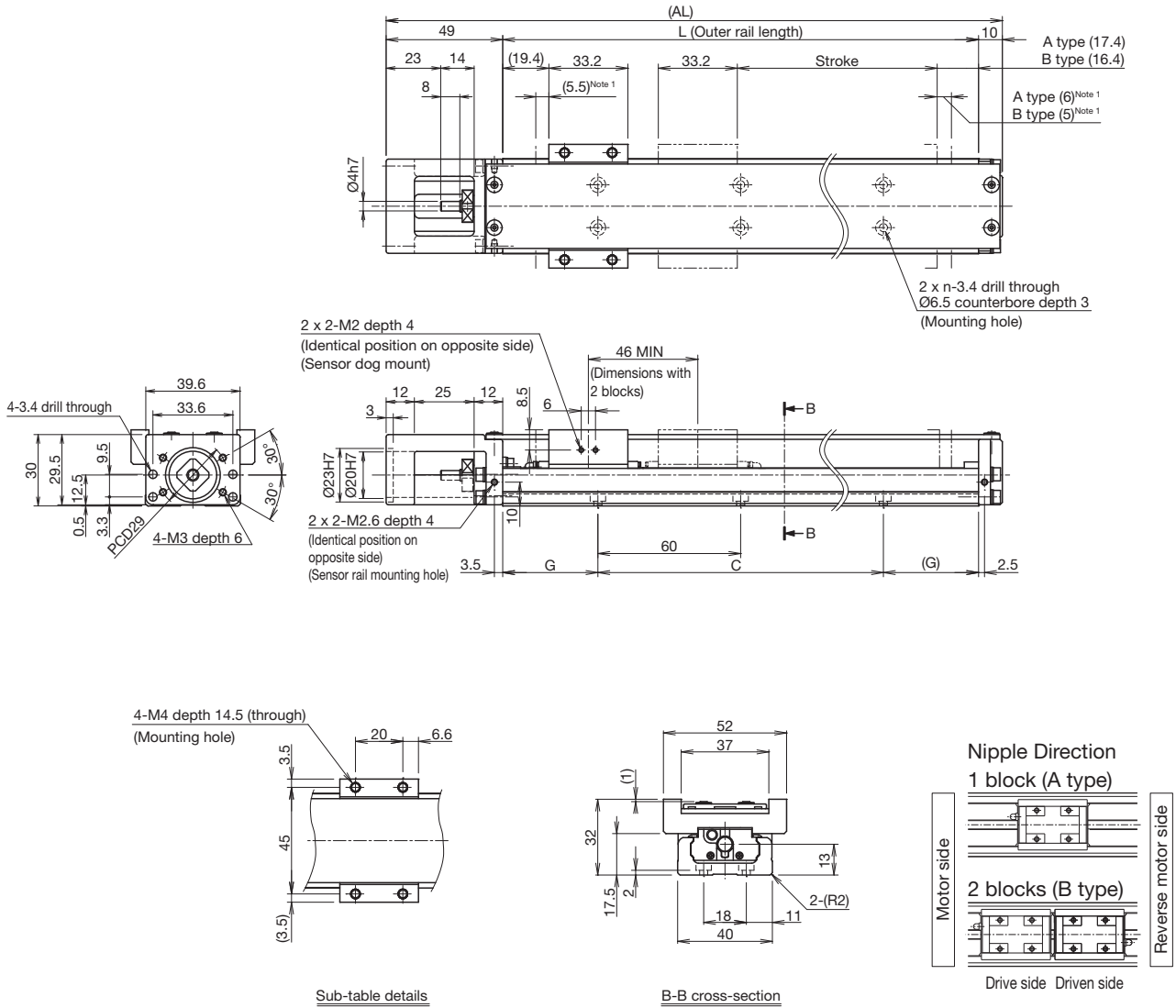

<sup>1</sup> Dimensions from the mechanical stopper to the stroke start position.

Stroke (mm) (Stroke between mechanical stoppers)	A type	30 (41.5)	80 (91.5)	130 (141.5)
	B type <sup>2</sup>	-	35 (45.5)	85 (95.5)
Maximum speed <sup>3</sup> (mm/s)	Ball screw lead: 1 mm		100	
	Ball screw lead: 6 mm		600	
Dimensions (mm)	AL	159	209	259
	L	100	150	200
	C	60	120	120
	G	20	15	40
No. of mounting holes	n	2	3	3
Mass <sup>4</sup> (kg)		0.56	0.71	0.85

<sup>2</sup> The value with 2 blocks (B type) attached.

<sup>3</sup> The maximum speed is restricted by the actuator's permissible speed.

<sup>4</sup> The mass with 2 blocks (B type) has 0.13 kg added.

Without Cover  
Direct Motor Coupling

**Dimensions**

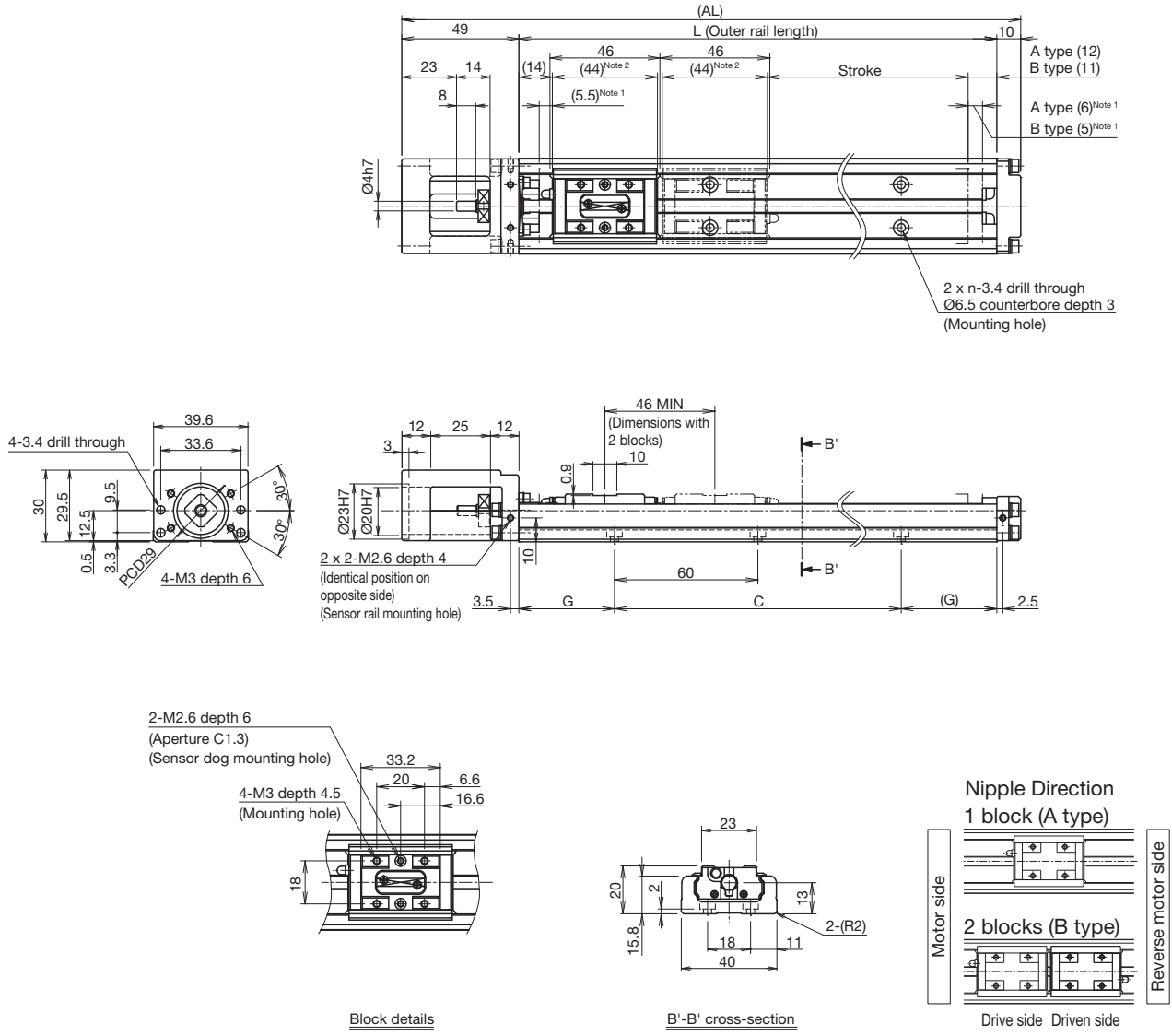

<sup>1</sup> Dimensions from the mechanical stopper to the stroke start position.  
<sup>2</sup> Shows the block length when calculating the enabled stroke range. 90 mm (2 blocks total) for KR20 with 2 blocks (B type).

Stroke (mm) (Stroke between mechanical stoppers)	A type	30 (41.5)	80 (91.5)	130 (141.5)
	B type <sup>3</sup>	-	35 (45.5)	85 (95.5)
Maximum speed <sup>4</sup> (mm/s)	Ball screw lead: 1 mm		100	
	Ball screw lead: 6 mm		600	
Dimensions (mm)	AL	159	209	259
	L	100	150	200
	C	60	120	120
	G	20	15	40
No. of mounting holes	n	2	3	3
Mass <sup>5</sup> (kg)		0.48	0.61	0.75

<sup>3</sup> The value with 2 blocks (B type) attached.  
<sup>4</sup> The maximum speed is restricted by the actuator's permissible speed.  
<sup>5</sup> The mass with 2 blocks (B type) has 0.08 kg added.

With Cover  
Motor Wrap

Dimensions

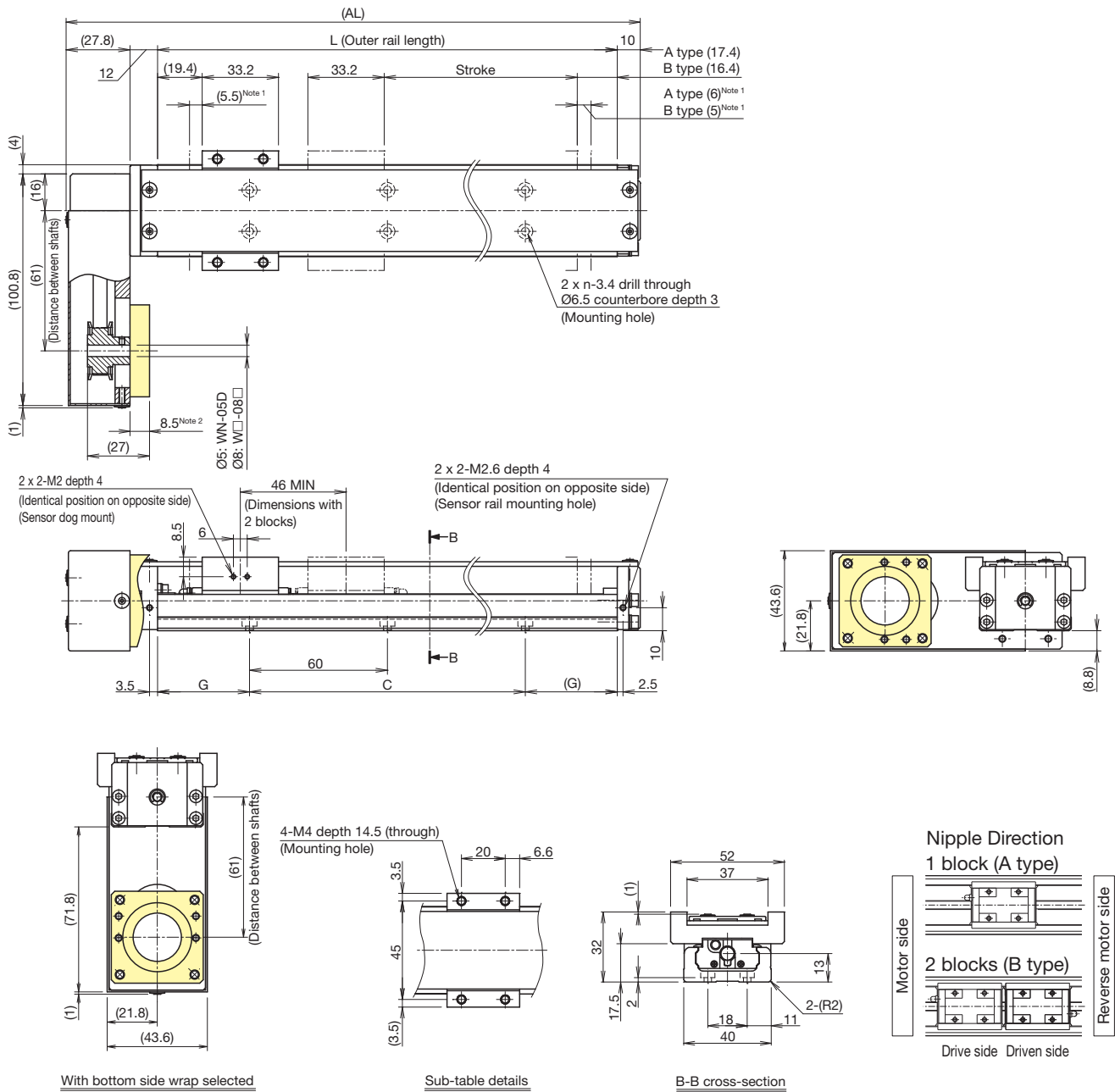

<sup>1</sup> Dimensions from the mechanical stopper to the stroke start position.  
<sup>2</sup> This dimension will be different if "WN" was selected for ⑨ Housing A/  
Intermediate flange in the model number coding. See p. 30 for details.

Stroke (mm) (Stroke between mechanical stoppers)	A type	30 (41.5)	80 (91.5)	130 (141.5)
	B type <sup>2</sup>	-	35 (45.5)	85 (95.5)
Maximum speed <sup>3</sup> (mm/s)	Ball screw lead: 1 mm	100		
	Ball screw lead: 6 mm	600		
Dimensions (mm)	AL	149.8	199.8	249.8
	L	100	150	200
	C	60	120	120
	G	20	15	40
No. of mounting holes	n	2	3	3
Mass <sup>4</sup> (kg)		0.82	0.96	1.11

<sup>2</sup> The value with 2 blocks (B type) attached.  
<sup>3</sup> The maximum speed is restricted by the actuator's permissible speed.  
<sup>4</sup> The mass with 2 blocks (B type) has 0.13 kg added.

Without Cover  
Motor Wrap

**Dimensions**

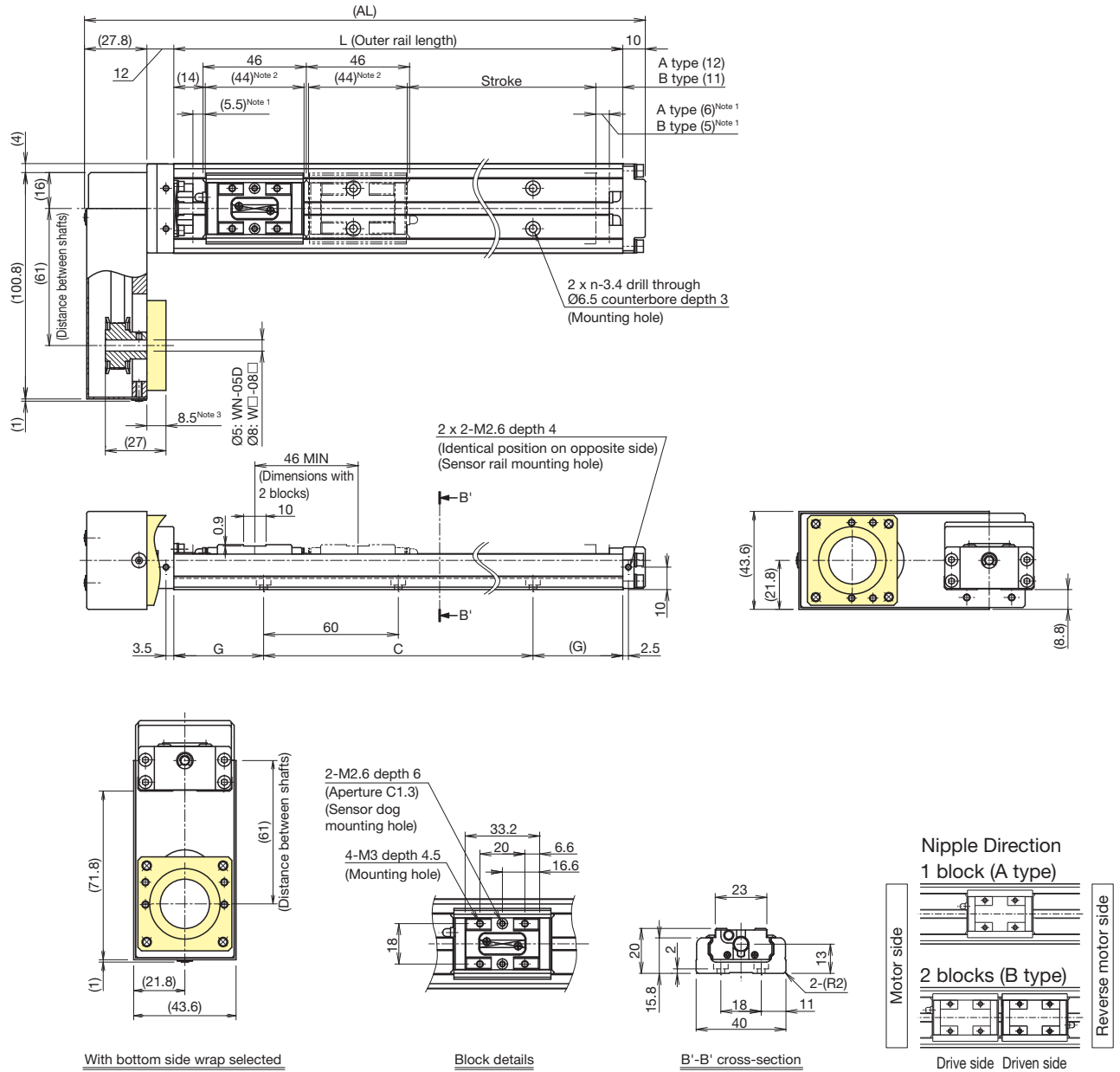

With bottom side wrap selected

Block details

B'-B' cross-section

Drive side Driven side

<sup>1</sup> Dimensions from the mechanical stopper to the stroke start position.  
<sup>2</sup> Shows the block length when calculating the enabled stroke range.  
 90 mm (2 blocks total) for KR20 with 2 blocks (B type).  
<sup>3</sup> This dimension will be different if "WN" was selected for <sup>9</sup> Housing A/  
 Intermediate flange in the model number coding. See p. 30 for details.

Stroke (mm) (Stroke between mechanical stoppers)	A type	30 (41.5)	80 (91.5)	130 (141.5)
	B type <sup>3</sup>	-	35 (45.5)	85 (95.5)
Maximum speed <sup>4</sup> (mm/s)	Ball screw lead: 1 mm	100	600	
	Ball screw lead: 6 mm			
Dimensions (mm)	AL	149.8	199.8	249.8
	L	100	150	200
	C	60	120	120
	G	20	15	40
No. of mounting holes	n	2	3	3
Mass <sup>5</sup> (kg)		0.73	0.87	1.01

<sup>3</sup> The value with 2 blocks (B type) attached.  
<sup>4</sup> The maximum speed is restricted by the actuator's permissible speed.  
<sup>5</sup> The mass with 2 blocks (B type) has 0.08 kg added.

# Options

## Sensors

Optional photo sensors and proximity sensors are available. Sensor-equipped models also feature a dedicated sensor rail and sensor dog.

Sensors, sensor rails, and sensor dogs can be mounted on both sides when the stroke is less than 70 mm.

Mounting example

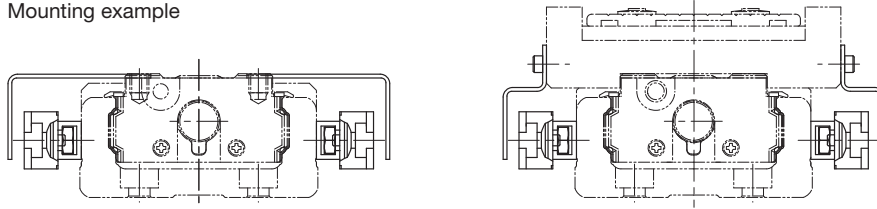

Symbol	Description	Model	Accessories
0	None	-	-
1	With sensor rail	-	Mounting screws, sensor rail (x1 or 2)
2	Photo sensor <sup>1</sup> (x3)	EE-SX671 (OMRON Corporation)	Mounting screws, nuts, sensor dog (x1 or 2), sensor rail (x1 or 2), mounting plates (x3), connectors (EE-1001 x3)
6	Photo sensor <sup>1</sup> (x3)	EE-SX674 (OMRON Corporation)	Mounting screws, nuts, sensor dog (x1 or 2), sensor rail (x1 or 2), mounting plates (x3), connectors (EE-1001 x3)
7	Proximity sensor N.O. contact <sup>2</sup> (x3)	APM-D3A1-001 (Azbil Corporation)	Mounting screws, nuts, sensor dog (x1 or 2), sensor rail (x1 or 2)
B	Proximity sensor N.C. contact <sup>3</sup> (x3)	APM-D3B1-003 (Azbil Corporation)	Mounting screws, nuts, sensor dog (x1 or 2), sensor rail (x1 or 2)
E	Proximity sensor N.O. contact <sup>2</sup> (x1) N.C. contact <sup>3</sup> (x2)	APM-D3A1-001 (Azbil Corporation) APM-D3B1-003 (Azbil Corporation)	Mounting screws, nuts, sensor dog (x1 or 2), sensor rail (x1 or 2)
H	Proximity sensor N.O. contact <sup>2</sup> (x3)	GX-F12A (Panasonic Industry Co., Ltd.)	Mounting screws, nuts, sensor dog (x1 or 2), sensor rail (x1 or 2)
L	Proximity sensor N.C. contact <sup>3</sup> (x3)	GX-F12B (Panasonic Industry Co., Ltd.)	Mounting screws, nuts, sensor dog (x1 or 2), sensor rail (x1 or 2)
J	Proximity sensor N.O. contact <sup>2</sup> (x1) N.C. contact <sup>3</sup> (x2)	GX-F12A (Panasonic Industry Co., Ltd.) GX-F12B (Panasonic Industry Co., Ltd.)	Mounting screws, nuts, sensor dog (x1 or 2), sensor rail (x1 or 2)
M	Proximity sensor N.O. contact <sup>2</sup> (x1) (PNP output) N.C. contact <sup>3</sup> (x2) (PNP output)	GX-F12A-P (Panasonic Industry Co., Ltd.) GX-F12B-P (Panasonic Industry Co., Ltd.)	Mounting screws, nuts, sensor dog (x1 or 2), sensor rail (x1 or 2)

<sup>1</sup> The photo sensors can be switched between ON when lit and ON when unlit.

<sup>2</sup> N.O. contact: Normally open contact point

<sup>3</sup> N.C. contact: Normally closed contact point

Notes: 1. If proximity sensors are close to one another, they may not function properly. If that happens, please prepare a type with a different frequency.

2. Mounting of sensors other than those in the table above is possible. Contact THK for details.

## Sensor Rail Mounting Dimensions

Mounting only a sensor rail is also possible.

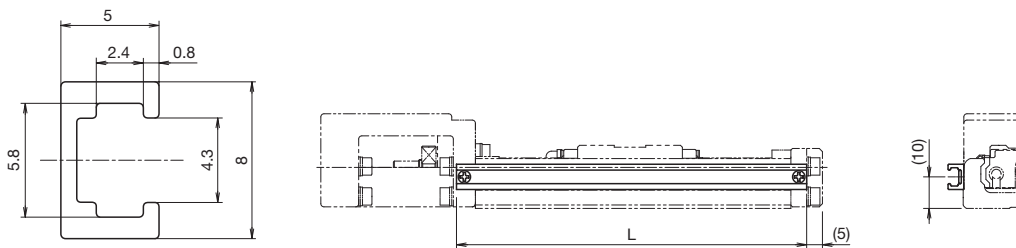

Sensor rail details

Stroke <sup>4</sup> (mm)	Outer rail length (mm)	L (mm)
30	100	111
80	150	161
130	200	211

<sup>4</sup> Stroke with 1 block (A type).

### Photo Sensor Mounting Dimensions

Connector: EE-1001 (OMRON Corporation) x3 included.  
To be mounted by the customer.

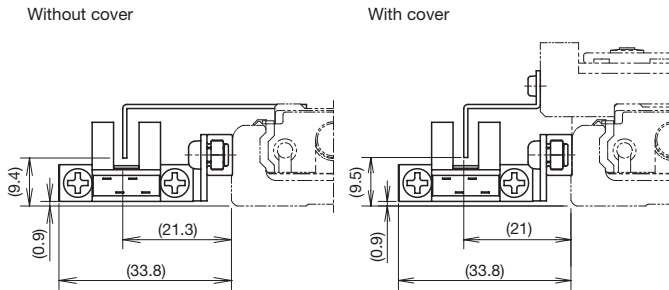

Symbol	Model	Manufacturer
2	EE-SX671	OMRON Corporation

Sensor dog width: 10 mm

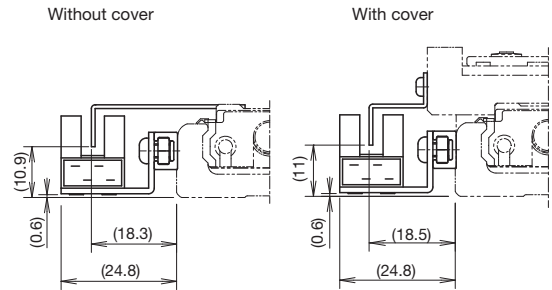

Symbol	Model	Manufacturer
6	EE-SX674	OMRON Corporation

Sensor dog width: 10 mm

### Proximity Sensor Mounting Dimensions

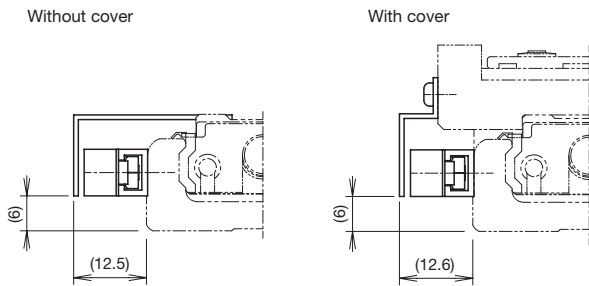

Symbol	Model	Manufacturer
7, B, E	APM-D3A1-001	Azbil Corporation
	APM-D3B1-003	

Sensor dog width: 10 mm

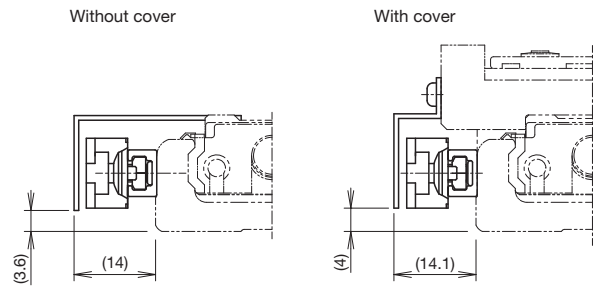

Symbol	Model	Manufacturer
H, L, J	GX-F12A	Panasonic Industry Co., Ltd.
	GX-F12B	
M	GX-F12A-P	
	GX-F12B-P	

Sensor dog width: 10 mm

# Options

## Intermediate Flange (Direct Coupling)

Several types of intermediate flanges for mounting motors are available.

When selecting "0" or "1" for Model Number Coding ⑥ With/without motor, specify an intermediate flange that matches the motor used.

Compatibility Table: Motors Used, Intermediate Flanges, and Couplings

Motor type	Manufacturer	Series	Motor model	Motor rated output (W)	Flange size	Housing A/ Intermediate flange	Compatible coupling models		
							MIKI PULLEY CO., LTD.	Nabeya Bi-tech Kaisha (NBK)	
AC servo motor	YASKAWA Electric Corporation	Σ-Vmini	SGMMV-A1	10	25×25	AN	SFC-010DA2-4B-5B-L32	XGT2-15C-4-5	
			SGMMV-A2	20					
			SGMMV-A3	30					
		Σ-V	SGMJV-A5	50	40×40	AQ	SFC-010DA2-4B-8B	XGT2-19C-4-8	
			SGMAV-A5						
			SGM7J-A5						
		Σ-7	SGM7A-A5	50	40×40	AQ	SFC-010DA2-4B-8B	XGT2-19C-4-8	
			SGM7A-A5						
		Σ-X	SGMXJ-A5	50	40×40	AQ	SFC-010DA2-4B-8B	XGT2-19C-4-8	
			SGMXA-A5						
	Mitsubishi Electric Corporation	MELSERVO	J4	HG-AK0136	10	25×25	AN	SFC-010DA2-4B-5B-L32	XGT2-15C-4-5
				HG-AK0236	20				
				HG-AK0336	30				
			J5	HG-KR053	50	40×40	AQ	SFC-010DA2-4B-8B	XGT2-19C-4-8
				HG-MR053					
				HK-KT053W	50				
	JN	HF-KN053	50	40×40	AQ	SFC-010DA2-4B-8B	XGT2-19C-4-8		
	TAMAGAWA SEIKI CO., LTD.	TBL-iii	TS4602	50	40×40	AQ	SFC-010DA2-4B-8B	XGT2-19C-4-8	
		TBL-iv	TSM3102						
Panasonic Corporation	MINAS	A5	MSMD5A	50	38×38	AP	SFC-010DA2-4B-8B	XGT2-19C-4-8	
			MSME5A		38×38	AP	SFC-010DA2-4B-8B	XGT2-19C-4-8	
		A6	MSMF5A	50					40×40
		MHMF5A							
KEYENCE CORPORATION	SV	SV-M005	50	40×40	AQ	SFC-010DA2-4B-8B	XGT2-19C-4-8		
	SV2	SV2-M005							
SANYO DENKI CO., LTD.	SANMOTION R	R2□A04005	50	40×40	AQ	SFC-010DA2-4B-8B	XGT2-19C-4-8		
OMRON Corporation	OMNUC G5	R88M-K05030	50	40×40	AQ	SFC-010DA2-4B-8B	XGT2-19C-4-8		
FANUC CORPORATION	βis Series	βis0.2/5000	50	40×40	AQ	SFC-010DA2-4B-8B	XGT2-19C-4-8		

Motor type	Manufacturer	Series	Motor model	Flange size	Housing A/ Intermediate flange	Compatible coupling models		
						MIKI PULLEY CO., LTD.	Nabeya Bi-tech Kaisha (NBK)	
Stepper motor	ORIENTAL MOTOR CO., LTD.	α step	AZ2*, AR2*	28×28	AS	SFC-010DA2-4B-5B-L32	XGT2-15C-4-5	
			AZ4*, AR4* (excluding AZM48)	42×42	AR	SFC-010DA2-4B-6B	XGT2-15C-4-6	
			AZM48			SFC-010DA2-4B-8B	XGT2-19C-4-8	
		5-phase	CRK	CRK52*	28×28	AS	SFC-010DA2-4B-5B-L32	XGT2-15C-4-5
				CRK54*	42×42	AR	SFC-010DA2-4B-5B	
				RK54*	42×42	AR	SFC-010DA2-4B-6B	
			PKP	PKP52*	28×28	AS	SFC-010DA2-4B-5B-L32	XGT2-15C-4-5
				PKP54*	42×42	AR	SFC-010DA2-4B-5B	
				PKP22*	28×28	AS	SFC-010DA2-4B-5B-L32	
		2-phase	PKP/CVD	PKP24*	42×42	AR	SFC-010DA2-4B-5B	XGT2-15C-4-5
				QS-M28	28×28	AS	SFC-010DA2-4B-5B-L32	XGT2-15C-4-5
		KEYENCE CORPORATION	2-phase	QS-M42	42×42	AR	SFC-010DA2-4B-5B	
	PBDM28*			28×28	AS	SFC-010DA2-4B-5B	XGT2-15C-4-5	
	SANYO DENKI CO., LTD.	PB	PBDM423, PBA**423	42×42	AR	SFC-010DA2-4B-6B	XGT2-15C-4-6	
			FAF/FDF52*	28×28	AS	SFC-010DA2-4B-5B-L32	XGT2-15C-4-5	
			FAF54*/FDF54*/FA511M42/FB511M42	42×42	AR	SFC-010DA2-4B-6B	XGT2-15C-4-6	
		5-phase	D*14S28*	28×28	AS	SFC-010DA2-4B-5B-L32	XGT2-15C-4-5	
			2-phase	DB14H52*	42×42	AR	SFC-010DA2-4B-5B	XGT2-15C-4-5
DU15H52*								

Notes: 1. The table shows only a portion of the model numbers for motors. For details regarding model numbers, please see the catalog for each respective motor manufacturer.  
 2. If the maximum torque for motors exceeds the permissible input torque (p. 19), please consider a safety measure to limit the torque.  
 3. When installing a motor other than the motor model numbers listed above, contact THK.

Housing A

KR20
A0

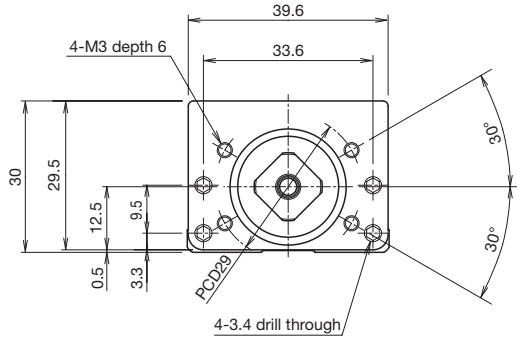

KR**	Actuator model
●◇	●: Housing A ◇: Intermediate flange

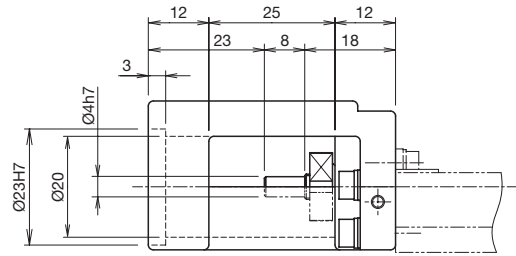

Intermediate Flange

KR20
AP

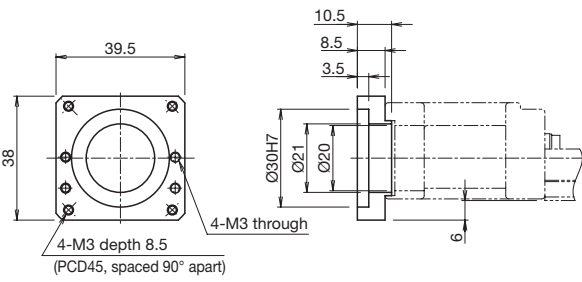

KR20
AQ

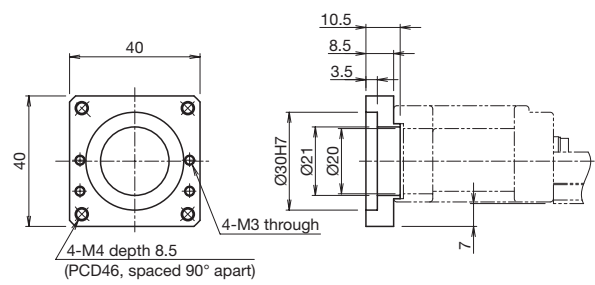

KR20
AR

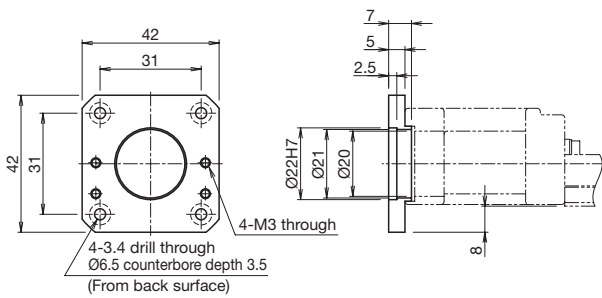

KR20
AS

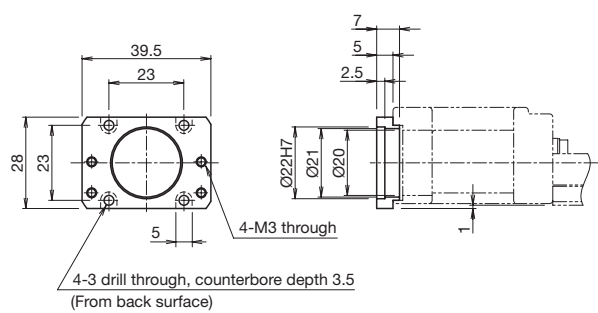

KR20
AN

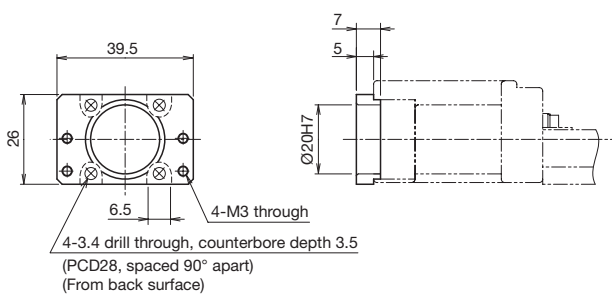

# Options

## Intermediate Flange (Motor Wrap)

Several types of intermediate flanges for mounting motors are available.

When selecting "R1," "R2," "R3," "R4," "R5," or "R6" for Model Number Coding ⑥ With/without motor, specify an intermediate flange that matches the motor used.

### Symbol Coding

Motor wrap symbol ①	Intermediate flange ②	Motor shaft diameter (mm) ③	Motor shaft securing method ④
W	Q	08	D
w	Refer to the Compatibility Table: Motors Used and Motor Wrap Symbols below.	Specify a motor shaft diameter. (Refer to the Compatibility Table: Motors Used and Motor Wrap Symbols below.)	K: Key D: D-cut

### Motor Shaft Securing Method

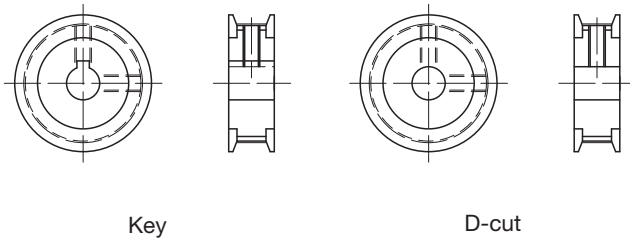

Compatibility Table: Motors Used and Motor Wrap Symbols

Motor type	Manufacturer	Series	Motor model	Motor rated output (W)	Flange size	Housing A/Intermediate flange	
AC servo motor	YASKAWA Electric Corporation	Σ-Vmini	SGMMV-A1	10	25×25	WN-05D	
			SGMMV-A2	20			
			SGMMV-A3	30			
		Σ-V	SGMJV-A5	50	40×40	WQ-08K	
							SGMAV-A5
			SGM7J-A5	50	40×40		
							SGM7A-A5
		Σ-X	SGMXJ-A5	50	40×40	WQ-08K	
			SGMXA-A5				
		Mitsubishi Electric Corporation	MELSERVO	J4	HG-AK0136	10	25×25
	HG-AK0236				20		
	HG-AK0336				30		
	J5			HG-KR053	50	40×40	WQ-08D
				HG-MR053			
				HK-KT053W			
	JN	HF-KN053	50	40×40	WQ-08D		
	TAMAGAWA SEIKI CO., LTD.	TBL-iii	TS4602	50	40×40	WQ-08D	
		TBL-iv	TSM3102				
	Panasonic Corporation	MINAS	A5	MSMD5A	50	38×38	WP-08D, WP-08K
				MSME5A			
A6			MSMF5A	50	38×38		
			MHMF5A		40×40		
KEYENCE CORPORATION	SV	SV-M005	50	40×40	WQ-08K		
	SV2	SV2-M005					
SANYO DENKI CO., LTD.	SANMOTION R	R2□A04005	50	40×40	WQ-08K		
OMRON Corporation	OMNUC G5	R88M-K05030	50	40×40	WQ-08K		
FANUC CORPORATION	βis Series	βis0.2/5000	50	40×40	WQ-08K		

Notes: 1. The table shows only a portion of the model numbers for motors. For details regarding model numbers, please see the catalog for each respective motor manufacturer.  
 2. If the maximum torque for motors exceeds the permissible input torque (p. 19), please consider a safety measure to limit the torque.  
 3. When installing a motor other than the motor model numbers listed above, contact THK.

Motor Wrap Housing A

KR20
20

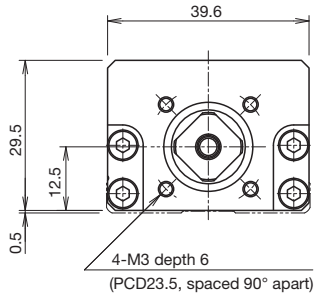

KR**	Actuator model
●◇	●: Housing A ◇: Intermediate flange

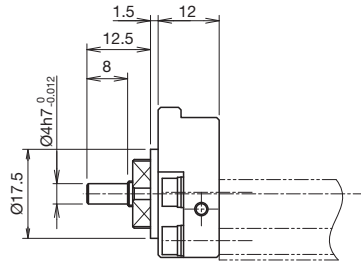

Note: The shaft end must be considered separately with motor wrap types. Contact THK for details.

Motor Wrap Specification (Intermediate Flange)

KR20
WP

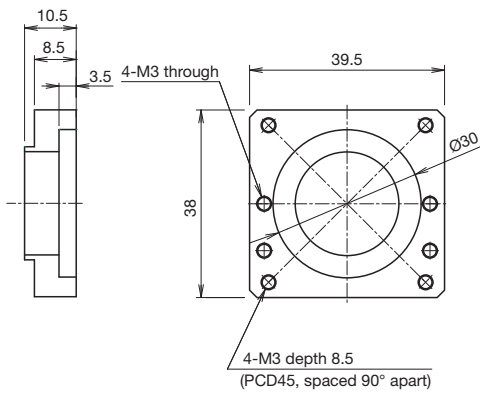

KR20
WQ

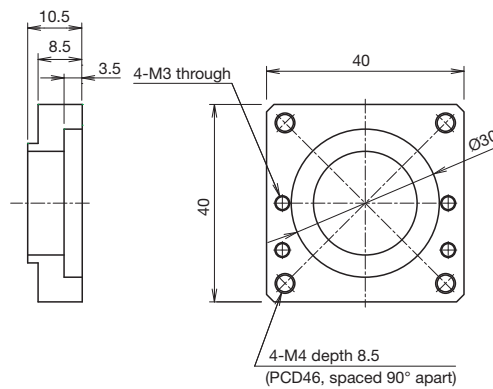

KR**	Actuator model
W□	□: Intermediate flange

KR20
WN

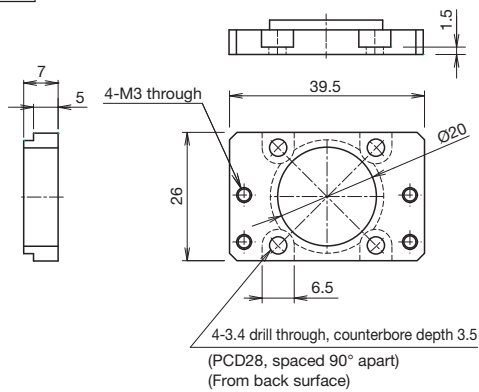

# KR26 A/B

Direct motor coupling

Motor wrap

Width 50 mm

Height 26 mm

Max. stroke 210 mm

## Model Number Coding

Model	Ball screw lead	Block type	Stroke	Accuracy grade	With/without motor	Cover	Sensors	Housing A/ Intermediate flange
①	②	③	④	⑤	⑥	⑦	⑧	⑨
KR26	02	A	0060	P	0	1	2	AQ
<b>KR26</b>	<b>02: 2 mm</b> <b>06: 6 mm</b>	<b>A: x1</b> <b>B: x2</b>	<b>0045: 45 mm</b> to <b>0210: 210 mm</b>	<b>No symbol:</b> Normal grade <b>H:</b> High accuracy grade <b>P:</b> Precision grade	<b>0:</b> Direct coupling (without motor) <b>1:</b> Direct coupling (THK will purchase and mount the motor you specify.) <b>With motor wrap</b> <b>R1:</b> Non-standard side wrap (without motor) <b>R2:</b> Standard side wrap (without motor) <b>R3:</b> Bottom side wrap (without motor) <b>R4:</b> Non-standard side wrap (THK will purchase and mount the motor you specify.) <b>R5:</b> Standard side wrap (THK will purchase and mount the motor you specify.) <b>R6:</b> Bottom side wrap (THK will purchase and mount the motor you specify.)	<b>0:</b> Without cover <b>1:</b> With cover <b>2:</b> With bellows	<b>0</b> <b>1</b> <b>2</b> <b>6</b> <b>7</b> <b>B</b> <b>E</b> <b>H</b> <b>L</b> <b>J</b> <b>M</b>	<b>With direct coupling</b> <b>A0</b> <b>AN</b> <b>AP</b> <b>AQ</b> <b>AR</b> <b>AS</b> <b>20</b> <b>With motor wrap</b> <b>WN-05D</b> <b>WP-08D</b> <b>WP-08K</b> <b>WQ-08D</b> <b>WQ-08K</b>
			When selecting 2: With bellows for ⑦ Cover, specify the stroke with bellows. → p. 165 to p. 166		When selecting "0": A coupling is not provided. Indicate when placing an order if a coupling is required.		Sensor details → p. 37	
			When selecting "1," "R4," "R5," or "R6": The specified motor will be installed. Indicate the motor cable direction separately. Select ⑨ Intermediate flange to match the specified motor.				With direct coupling → p. 39 With motor wrap → p. 41	

### ③ Block Type

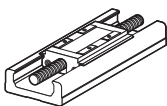

A: 1 block (A type)

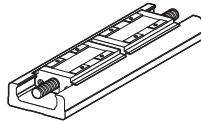

B: 2 blocks (B type)

### ⑥ Motor Mounting Method

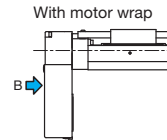
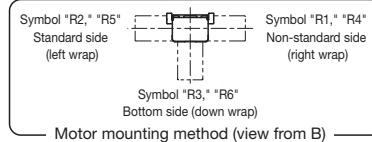

## Selection Information

### Basic Specifications

LM Guide	Basic dynamic load rating C (N)		8,650
	Basic static load rating C <sub>0</sub> (N)		14,100
	Radial clearance (mm)	Normal grade/High accuracy grade (H)	-0.004 to +0.002
		Precision grade (P)	-0.01 to -0.004
Geometric moment of inertia	I <sub>x</sub> <sup>1</sup> (mm <sup>4</sup> )	1.7×10 <sup>4</sup>	
	I <sub>y</sub> <sup>2</sup> (mm <sup>4</sup> )	1.5×10 <sup>5</sup>	
	Mass (kg/m)	3.9	
Ball screw	Ball screw lead (mm)		2      6
	Basic dynamic load rating C <sub>a</sub> (N)	Normal grade/High accuracy grade (H)	2,350      1,950
		Precision grade (P)	2,390
	Basic static load rating C <sub>0a</sub> (N)	Normal grade/High accuracy grade (H)	4,020      3,510
		Precision grade (P)	3,900
	Screw shaft diameter (mm)		Ø8
	Thread minor diameter (mm)		Ø6.6      Ø6.7
	Ball center-to-center diameter (mm)		Ø8.3      Ø8.4
Permissible rotational speed <sup>3</sup> (min <sup>-1</sup> )	Normal grade/High accuracy grade (H)	5,900	
	Precision grade (P)	6,000	
Bearing unit (fixed side)	Axial direction	Basic dynamic load rating C <sub>a</sub> (N)	1,380
		Static permissible load P <sub>0a</sub> (N)	1,760
Permissible input torque (N·m)	Direct coupling	0.62      0.80	
	Motor wrap	0.40	
Static permissible moment <sup>4,5</sup> (N·m)		M <sub>A</sub> : 84 (480), M <sub>B</sub> : 84 (480) M <sub>C</sub> : 208 (416)	
Service life <sup>6</sup> (km)		3,000      5,000	
Standard grease/Grease nipple used		THK AFA Grease/PB107	

<sup>1</sup> I<sub>x</sub> is the geometric moment of inertia about the X axis.

<sup>2</sup> I<sub>y</sub> is the geometric moment of inertia about the Y axis.

<sup>3</sup> The permissible rotational speed may decrease as the stroke becomes longer.

<sup>4</sup> The value in parentheses is with 2 blocks (B type) attached.

<sup>5</sup> See p. 172 for the values if "1" or "2" is selected for item ⑦ in the Model Number Coding.

<sup>6</sup> Calculated under the following conditions.

Stroke: 160 mm (A type), 95 mm (B type) / Speed: 100 mm/s (for 2 mm lead), 300 mm/s (for 6 mm lead) / Load mass: Maximum load capacity (p. 9) / Acceleration/deceleration: As when set to maximum load capacity (p. 9) / Center of gravity: Center of the table's upper surface.

Note 1: LM Guide load rating is the load rating per block.

### Accuracy

Accuracy grade	Item	Stroke <sup>7</sup>			
		60	110	160	210
Normal grade (no symbol)	Positioning repeatability (mm)	±0.01			
	Positioning accuracy (mm)	Not specified			
	Running parallelism (vertical direction) (mm)	Not specified			
	Backlash (mm)	0.015			
	Starting torque (N·cm)	1.5			

Accuracy grade	Item	Stroke <sup>7</sup>			
		60	110	160	210
High accuracy grade (H)	Positioning repeatability (mm)	±0.004			
	Positioning accuracy (mm)	0.04			
	Running parallelism (vertical direction) (mm)	0.025			
	Backlash (mm)	0.01			
	Starting torque (N·cm)	1.5			

Accuracy grade	Item	Stroke <sup>7</sup>			
		60	110	160	210
Precision grade (P)	Positioning repeatability (mm)	±0.003			
	Positioning accuracy (mm)	0.02			
	Running parallelism (vertical direction) (mm)	0.01			
	Backlash (mm)	0.003			
	Starting torque (N·cm)	4			

<sup>7</sup> Stroke with 1 block (A type).

Notes: 2. Precision evaluation in accordance with THK standards.

3. Measured using a motor for inspection. With motor wrap specifications, measurements are not made in the completed motor wrap state.

4. The starting torque represents the value when containing THK AFA Grease.

5. The starting torque may exceed standards if using vacuum grease, clean room grease, or other high-viscosity greases, so care should be taken when selecting a motor.

6. Contact THK for accuracy higher than the standard stroke.

### Geometric Moment of Inertia

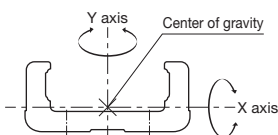

### Static Permissible Moment

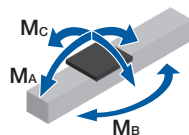

### Motor Selection Information

Stroke <sup>1</sup> (mm)	Outer rail length (mm)	LM Guide				Ball screw		Motor mounting part	
		Moving part mass (kg)			Sliding resistance value <sup>2</sup> (N)	Lead (mm)	Shaft length (mm)	Direct coupling	Motor wrap
		Block mass	Sub-table mass	Total mass				Shaft end diameter (mm)	Timing pulley (sum of two) Inertial moment x 10 <sup>-4</sup> (kg·m <sup>2</sup> )
60 to 210	150 to 300	A type: 0.19 B type: 0.38	A type: 0.09 B type: 0.18	A type: 0.28 B type: 0.56	1.4	2, 6	190 to 340	Ø5h7	0.013

<sup>1</sup> Stroke with 1 block (A type).

<sup>2</sup> Value with 1 block (A type). This value is the sum of the rolling resistance value and seal resistance value.

Note: Refer to p. 39 for applicable couplings.

### Permissible Overhang Length<sup>3</sup>

Horizontal

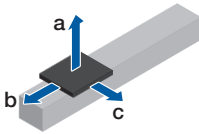

Wall-Mounted

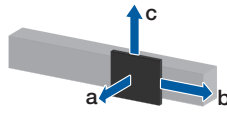

Vertical

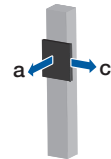

Estimated motor capacity 50 W	Ball screw lead (mm)	Load mass (kg)	a	b	c	
			(mm)	(mm)	(mm)	
Direct coupling	A type	2	6.5	500	120	330
			13.5	270	60	160
			27.5	120	20	70
		6	6.5	500	100	260
			13.5	270	40	120
			27.5	120	20	50
	B type	2	9.5	500	500	500
			19	500	240	250
			38.5	470	110	120
		6	9.5	500	430	420
			19	500	200	200
			38.5	470	90	90

Estimated motor capacity 50 W	Ball screw lead (mm)	Load mass (kg)	a	b	c	
			(mm)	(mm)	(mm)	
Direct coupling	A type	2	5.5	170	110	390
			11	70	50	190
			22	20	20	90
		6	4.5	220	140	480
			9	90	60	240
			18.5	30	20	110
	B type	2	7.5	270	240	500
			15.5	110	110	390
			31	40	50	190
		6	7.5	270	240	500
			15.5	110	110	390
			31	40	50	190

Estimated motor capacity 50 W	Ball screw lead (mm)	Load mass (kg)	a	c	
			(mm)	(mm)	
Direct coupling	A type	2	2	350	250
			4.5	160	110
			9.5	70	50
		6	1.5	400	330
			3.5	180	140
			7	80	70
	B type	2	2	500	500
			4.5	500	310
			9.5	440	140
		6	2	500	500
			4.5	500	310
			9.5	410	140

<sup>3</sup> This is the value with the service life of the LM Guide limited to 5,000 km (3,000 km for 2 mm lead only). The calculation conditions are as follows.  
Stroke: 135 mm (A type), 95 mm (B type) / Acceleration/deceleration: 0.3 G / Speed: 100 mm/s (for 2 mm lead), 300 mm/s (for 6 mm lead) / Overhang direction: Loaded only in a single direction.  
Dimensions a, b, and c are from the center of the table's upper surface.

With Cover  
Direct Motor Coupling

Dimensions

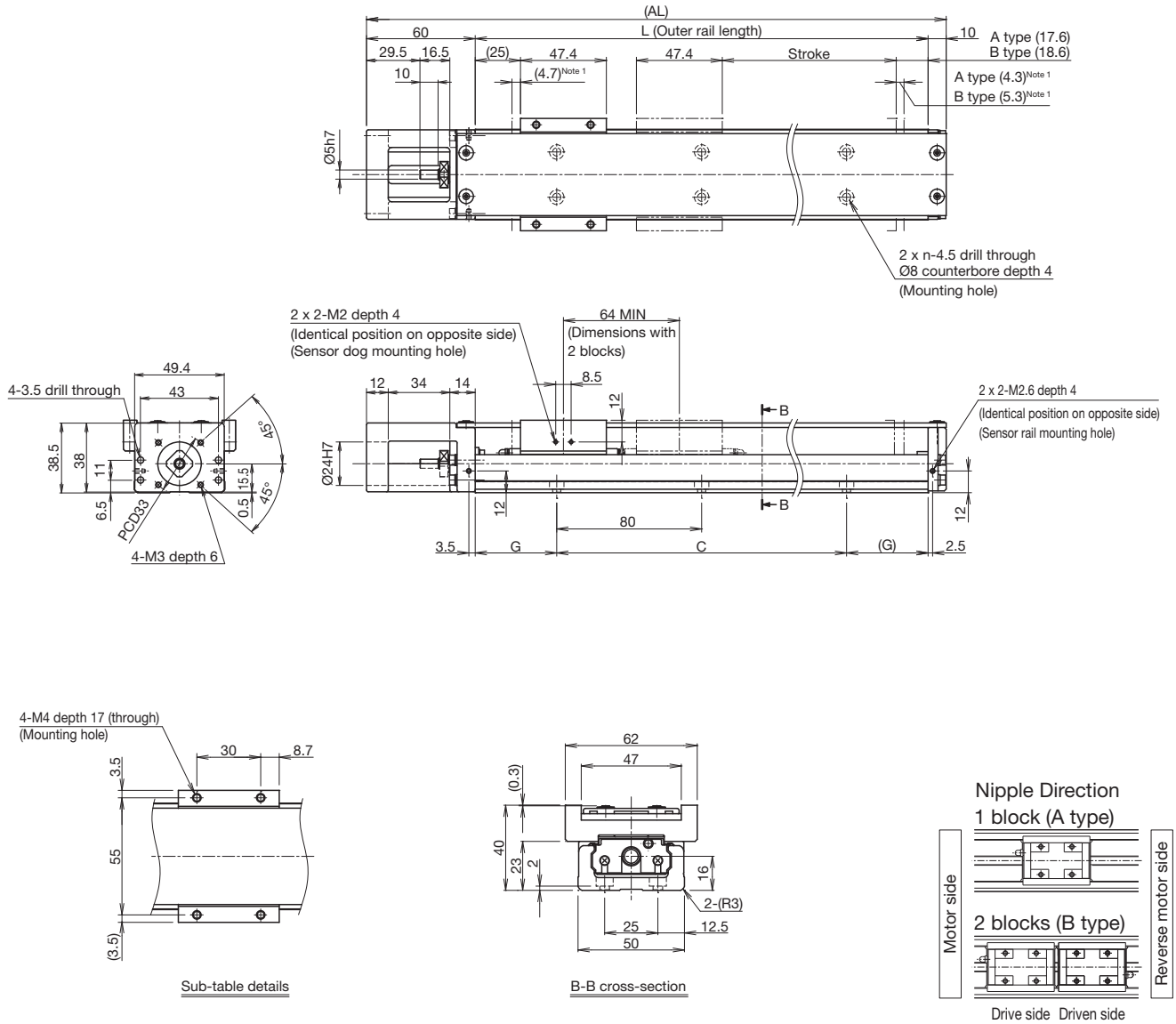

<sup>1</sup> Dimensions from the mechanical stopper to the stroke start position.

Stroke (mm) (Stroke between mechanical stoppers)	A type	60 (69)	110 (119)	160 (169)	210 (219)
	B type <sup>2</sup>	-	45 (55)	95 (105)	145 (155)
Maximum speed <sup>3</sup> (mm/s)	Ball screw lead: 2 mm		200		
	Ball screw lead: 6 mm	Normal grade/High accuracy grade	590		
		Precision grade	600		
Dimensions (mm)	AL	220	270	320	370
	L	150	200	250	300
	C	80	160	160	240
	G	35	20	45	30
No. of mounting holes	n	2	3	3	4
Mass <sup>4</sup> (kg)		1.2	1.42	1.65	1.87

<sup>2</sup> The value with 2 blocks (B type) attached.

<sup>3</sup> The maximum speed is restricted by the actuator's permissible speed.

<sup>4</sup> The mass with 2 blocks (B type) has 0.28 kg added.

Without Cover  
Direct Motor Coupling

**Dimensions**

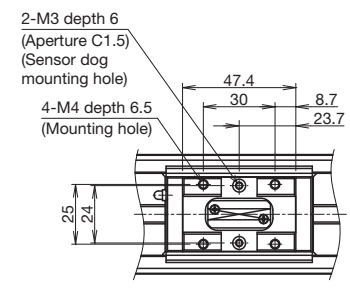
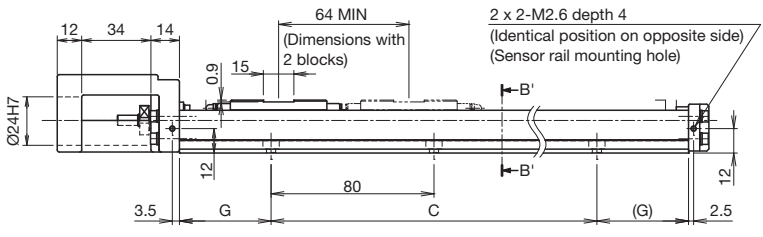
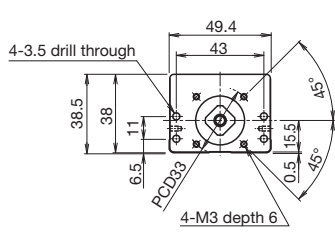
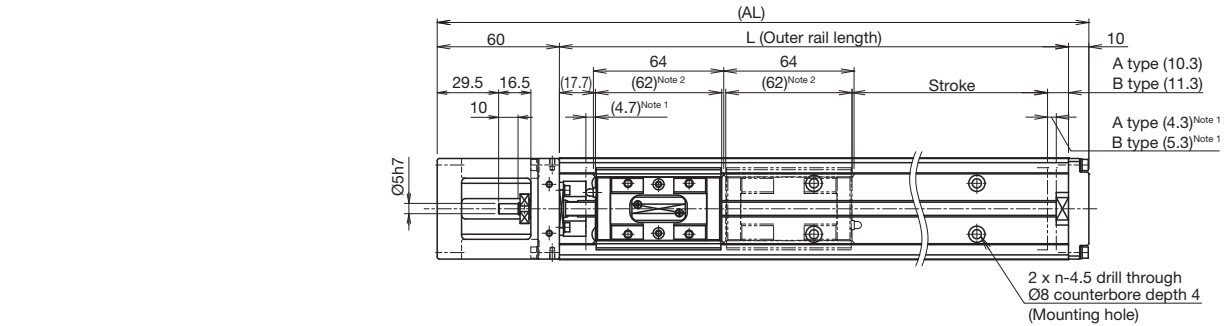

Block details

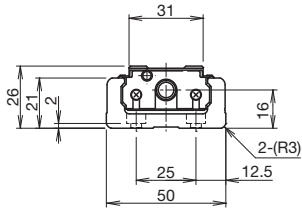

B'-B' cross-section

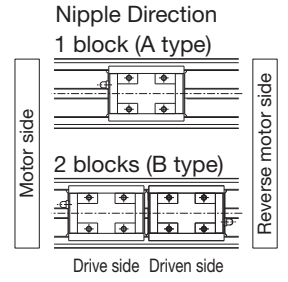

<sup>1</sup> Dimensions from the mechanical stopper to the stroke start position.  
<sup>2</sup> Shows the block length when calculating the enabled stroke range. 126 mm (2 blocks total) for KR26 with 2 blocks (B type).

Stroke (mm) (Stroke between mechanical stoppers)	A type	60 (69)	110 (119)	160 (169)	210 (219)
	B type <sup>3</sup>	-	45 (55)	95 (105)	145 (155)
Maximum speed <sup>4</sup> (mm/s)	Ball screw lead: 2 mm		200		
	Ball screw lead: 6 mm	Normal grade/High accuracy grade	590		
		Precision grade	600		
Dimensions (mm)	AL	220	270	320	370
	L	150	200	250	300
	C	80	160	160	240
	G	35	20	45	30
No. of mounting holes	n	2	3	3	4
Mass <sup>5</sup> (kg)		1.04	1.25	1.46	1.67

<sup>3</sup> The value with 2 blocks (B type) attached.  
<sup>4</sup> The maximum speed is restricted by the actuator's permissible speed.  
<sup>5</sup> The mass with 2 blocks (B type) has 0.19 kg added.

With Cover  
Motor Wrap

Dimensions

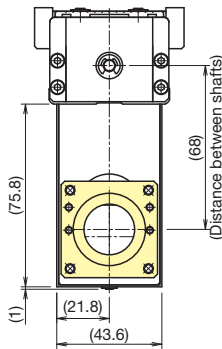
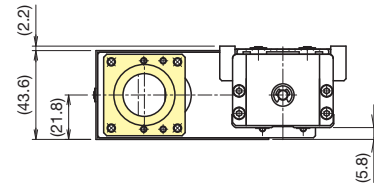
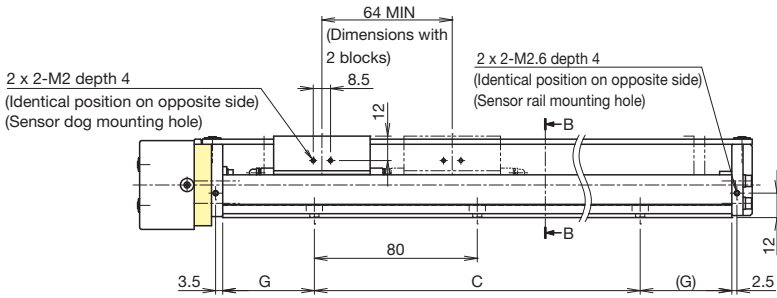
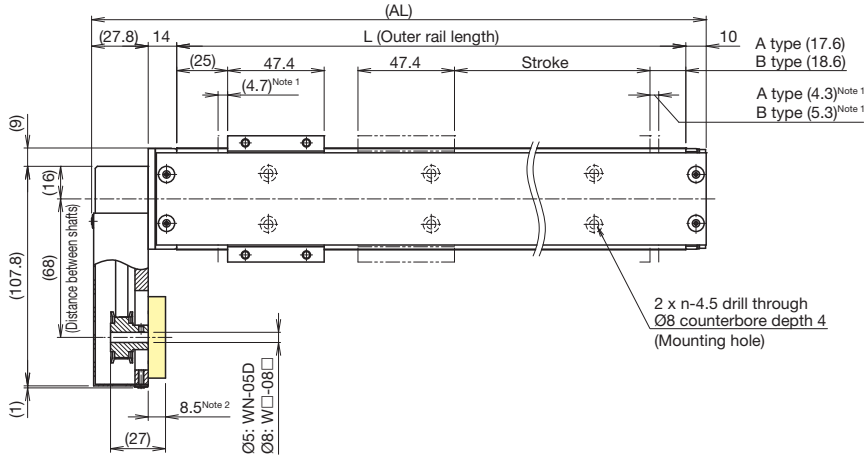

With bottom side wrap selected

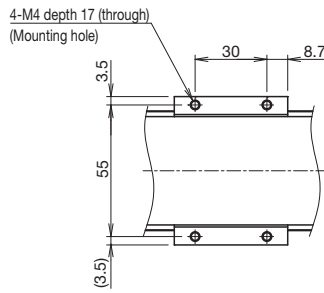

Sub-table details

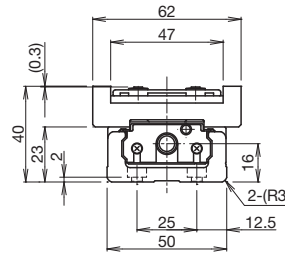

B-B cross-section

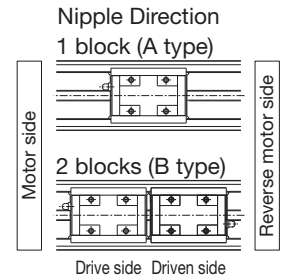

<sup>1</sup> Dimensions from the mechanical stopper to the stroke start position.  
<sup>2</sup> This dimension will be different if "WN" was selected for (9) Housing A/ Intermediate flange in the model number coding. See p. 42 for details.

Stroke (mm) (Stroke between mechanical stoppers)	A type	60 (69)	110 (119)	160 (169)	210 (219)
	B type <sup>2</sup>	-	45 (55)	95 (105)	145 (155)
	Ball screw lead: 2 mm				
Maximum speed <sup>3</sup> (mm/s)	Ball screw lead: 6 mm	Normal grade/High accuracy grade		200	
		Precision grade		590	
Dimensions (mm)	AL	201.8	251.8	301.8	351.8
	L	150	200	250	300
	C	80	160	160	240
	G	35	20	45	30
No. of mounting holes	n	2	3	3	4
	Mass <sup>4</sup> (kg)	1.43	1.65	1.87	2.1

<sup>2</sup> The value with 2 blocks (B type) attached.  
<sup>3</sup> The maximum speed is restricted by the actuator's permissible speed.  
<sup>4</sup> The mass with 2 blocks (B type) has 0.28 kg added.

Without Cover  
Motor Wrap

Dimensions

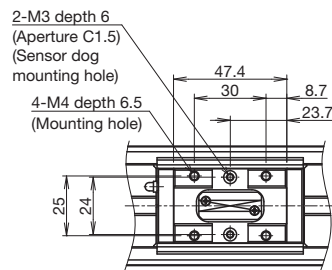
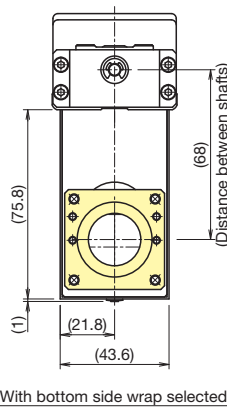
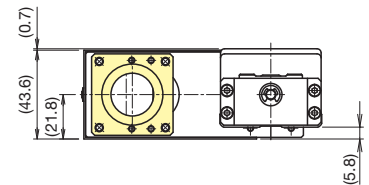
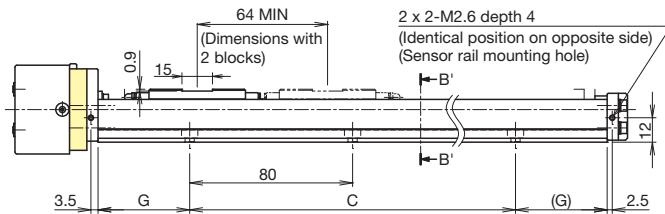
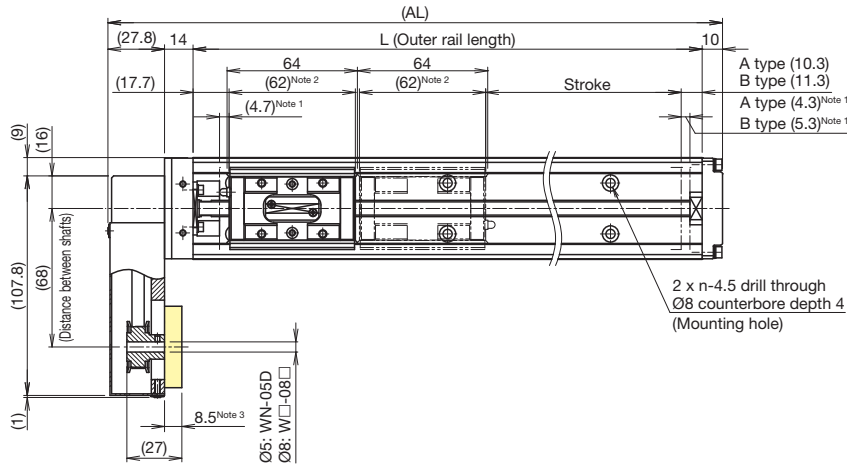

Block details

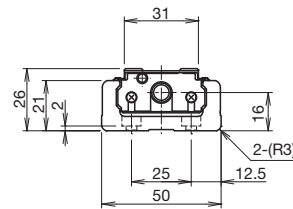

B'-B' cross-section

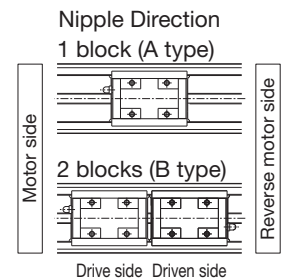

<sup>1</sup> Dimensions from the mechanical stopper to the stroke start position.  
<sup>2</sup> Shows the block length when calculating the enabled stroke range.  
126 mm (2 blocks total) for KR26 with 2 blocks (B type).  
<sup>3</sup> This dimension will be different if "WN" was selected for ⑨ Housing A/  
Intermediate flange in the model number coding. See p. 42 for details.

Stroke (mm) (Stroke between mechanical stoppers)	A type	60 (69)	110 (119)	160 (169)	210 (219)
	B type <sup>3</sup>	-	45 (55)	95 (105)	145 (155)
Maximum speed <sup>4</sup> (mm/s)	Ball screw lead: 2 mm	200			
	Ball screw lead: 6 mm	Normal grade/High accuracy grade	590		
		Precision grade	600		
Dimensions (mm)	AL	201.8	251.8	301.8	351.8
	L	150	200	250	300
	C	80	160	160	240
	G	35	20	45	30
No. of mounting holes	n	2	3	3	4
Mass <sup>5</sup> (kg)		1.26	1.47	1.69	1.9

<sup>3</sup> The value with 2 blocks (B type) attached.  
<sup>4</sup> The maximum speed is restricted by the actuator's permissible speed.  
<sup>5</sup> The mass with 2 blocks (B type) has 0.19 kg added.

# Options

## Sensors

Optional photo sensors and proximity sensors are available. Sensor-equipped models also feature a dedicated sensor rail and sensor dog.

Sensors, sensor rails, and sensor dogs can be mounted on both sides when the stroke is less than 70 mm.

Mounting example

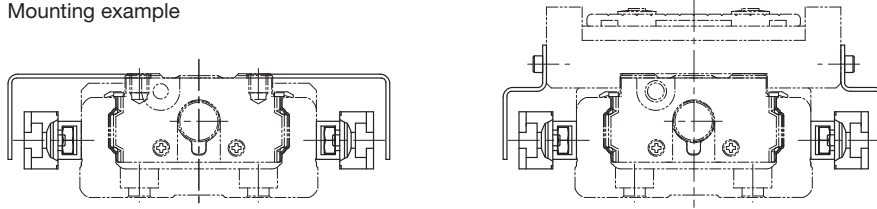

Symbol	Description	Model	Accessories
0	None	-	-
1	With sensor rail	-	Mounting screws, sensor rail (x1 or 2)
2	Photo sensor <sup>1</sup> (x3)	EE-SX671 (OMRON Corporation)	Mounting screws, nuts, sensor dog (x1 or 2), sensor rail (x1 or 2), mounting plates (x3), connectors (EE-1001 x3)
6	Photo sensor <sup>1</sup> (x3)	EE-SX674 (OMRON Corporation)	Mounting screws, nuts, sensor dog (x1 or 2), sensor rail (x1 or 2), mounting plates (x3), connectors (EE-1001 x3)
7	Proximity sensor N.O. contact <sup>2</sup> (x3)	APM-D3A1-001 (Azbil Corporation)	Mounting screws, nuts, sensor dog (x1 or 2), sensor rail (x1 or 2)
B	Proximity sensor N.C. contact <sup>3</sup> (x3)	APM-D3B1-003 (Azbil Corporation)	Mounting screws, nuts, sensor dog (x1 or 2), sensor rail (x1 or 2)
E	Proximity sensor N.O. contact <sup>2</sup> (x1) N.C. contact <sup>3</sup> (x2)	APM-D3A1-001 (Azbil Corporation) APM-D3B1-003 (Azbil Corporation)	Mounting screws, nuts, sensor dog (x1 or 2), sensor rail (x1 or 2)
H	Proximity sensor N.O. contact <sup>2</sup> (x3)	GX-F12A (Panasonic Industry Co., Ltd.)	Mounting screws, nuts, sensor dog (x1 or 2), sensor rail (x1 or 2)
L	Proximity sensor N.C. contact <sup>3</sup> (x3)	GX-F12B (Panasonic Industry Co., Ltd.)	Mounting screws, nuts, sensor dog (x1 or 2), sensor rail (x1 or 2)
J	Proximity sensor N.O. contact <sup>2</sup> (x1) N.C. contact <sup>3</sup> (x2)	GX-F12A (Panasonic Industry Co., Ltd.) GX-F12B (Panasonic Industry Co., Ltd.)	Mounting screws, nuts, sensor dog (x1 or 2), sensor rail (x1 or 2)
M	Proximity sensor N.O. contact <sup>2</sup> (x1) (PNP output) N.C. contact <sup>3</sup> (x2) (PNP output)	GX-F12A-P (Panasonic Industry Co., Ltd.) GX-F12B-P (Panasonic Industry Co., Ltd.)	Mounting screws, nuts, sensor dog (x1 or 2), sensor rail (x1 or 2)

<sup>1</sup> The photo sensors can be switched between ON when lit and ON when unlit.

<sup>2</sup> N.O. contact: Normally open contact point

<sup>3</sup> N.C. contact: Normally closed contact point

Notes: 1. If proximity sensors are close to one another, they may not function properly. If that happens, please prepare a type with a different frequency.

2. Mounting of sensors other than those in the table above is possible. Contact THK for details.

## Sensor Rail Mounting Dimensions

Mounting only a sensor rail is also possible.

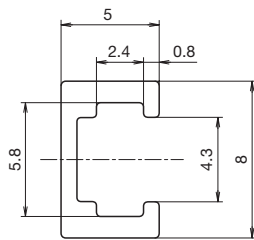

Sensor rail details

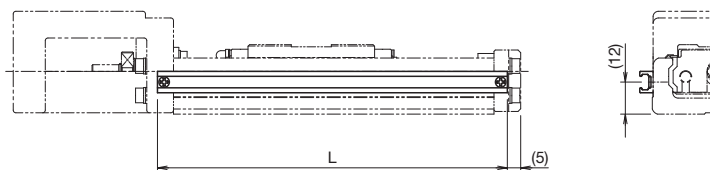

Stroke <sup>4</sup> (mm)	Outer rail length (mm)	L (mm)
60	150	161
110	200	211
160	250	261
210	300	311

<sup>4</sup> Stroke with 1 block (A type).

### Photo Sensor Mounting Dimensions

Connector: EE-1001 (OMRON Corporation) x3 included.  
To be mounted by the customer.

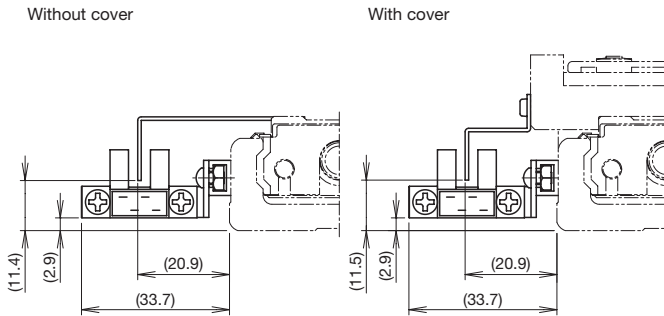

Symbol	Model	Manufacturer
2	EE-SX671	OMRON Corporation

Sensor dog width: 15 mm

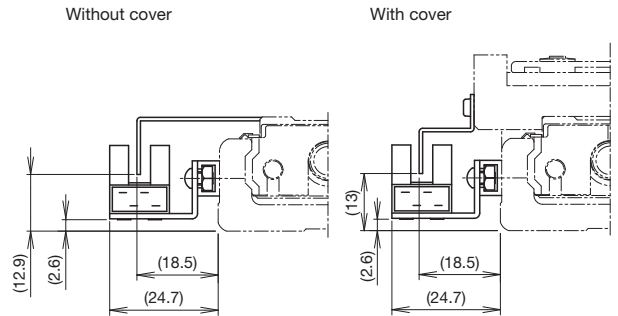

Symbol	Model	Manufacturer
6	EE-SX674	OMRON Corporation

Sensor dog width: 15 mm

### Proximity Sensor Mounting Dimensions

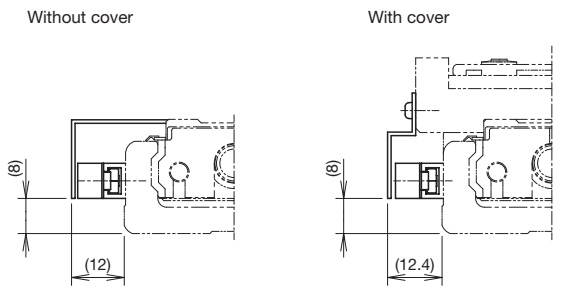

Symbol	Model	Manufacturer
7, B, E	APM-D3A1-001	Azbil Corporation
	APM-D3B1-003	

Sensor dog width: 15 mm

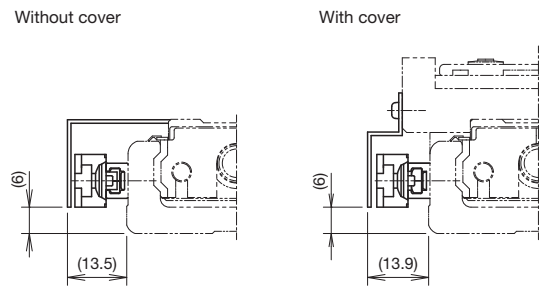

Symbol	Model	Manufacturer
H, L, J	GX-F12A	Panasonic Industry Co., Ltd.
	GX-F12B	
M	GX-F12A-P	
	GX-F12B-P	

Sensor dog width: 15 mm

# Options

## Intermediate Flange (Direct Coupling)

Several types of intermediate flanges for mounting motors are available.

When selecting "0" or "1" for Model Number Coding ⑥ With/without motor, specify an intermediate flange that matches the motor used.

Compatibility Table: Motors Used, Intermediate Flanges, and Couplings

Motor type	Manufacturer	Series	Motor model	Motor rated output (W)	Flange size	Housing A/ Intermediate flange	Compatible coupling models		
							MIKI PULLEY CO., LTD.	Nabeya Bi-tech Kaisha (NBK)	
AC servo motor	YASKAWA Electric Corporation	Σ-Vmini	SGMMV-A1	10	25×25	AN	SFC-010DA2-5B-5B-L37	XGL2-15C-5-5	
			SGMMV-A2	20					
			SGMMV-A3	30					
		Σ-V	SGMJV-A5	50	40×40	AQ	SFC-010DA2-5B-8B-L32	XGT2-19C-5-8	
			SGMAV-A5						
			SGM7J-A5						
		Σ-7	SGM7A-A5	50	40×40	AQ	SFC-010DA2-5B-8B-L32	XGT2-19C-5-8	
			SGMXA-A5	50	40×40	AQ	SFC-010DA2-5B-8B-L32	XGT2-19C-5-8	
		SGMJJ-A5							
		Mitsubishi Electric Corporation	MELSERVO	J4	HG-AK0136	10	25×25	AN	SFC-010DA2-5B-5B-L37
	HG-AK0236				20				
	HG-AK0336				30				
	J5			HG-KR053	50	40×40	AQ	SFC-010DA2-5B-8B-L32	XGT2-19C-5-8
				HG-MR053					
				HK-KT053W					
	JN		HF-KN053	50	40×40	AQ	SFC-010DA2-5B-8B-L32	XGT2-19C-5-8	
			TAMAGAWA SEIKI CO., LTD.	TBL-iii	TS4602	50	40×40	AQ	SFC-010DA2-5B-8B-L32
	TBL-iv		TSM3102						
	Panasonic Corporation		MINAS	A5	MSMD5A	50	38×38	AP	SFC-010DA2-5B-8B-L32
		MSME5A							
A6		MSMF5A		50	38×38	AP	SFC-010DA2-5B-8B-L32	XGT2-19C-5-8	
		MHMF5A			40×40	AQ	SFC-010DA2-5B-8B-L32	XGT2-19C-5-8	
KEYENCE CORPORATION	SV	SV-M005	50	40×40	AQ	SFC-010DA2-5B-8B-L32	XGT2-19C-5-8		
SV2	SV2-M005								
SANYO DENKI CO., LTD.	SANMOTION R	R2□A04005	50	40×40	AQ	SFC-010DA2-5B-8B-L32	XGT2-19C-5-8		
OMRON Corporation	OMNUC G5	R88M-K05030	50	40×40	AQ	SFC-010DA2-5B-8B-L32	XGT2-19C-5-8		
FANUC CORPORATION	βis Series	βis0.2/5000	50	40×40	AQ	SFC-010DA2-5B-8B-L32	XGT2-19C-5-8		

Motor type	Manufacturer	Series	Motor model	Flange size	Housing A/ Intermediate flange	Compatible coupling models		
						MIKI PULLEY CO., LTD.	Nabeya Bi-tech Kaisha (NBK)	
Stepper motor	ORIENTAL MOTOR CO., LTD.	α step	AZ2*, AR2*	28×28	AS	SFC-010DA2-5B-5B-L39	XGL2-15C-5-5	
			AZ4*, AR4* (excluding AZM48)	42×42	AR	SFC-010DA2-5B-6B-L37	XGL2-15C-5-6	
			AZM48	42×42	AR	SFC-010DA2-5B-8B-L32	XGT2-19C-5-8	
			CRK52*	28×28	AS	SFC-010DA2-5B-5B-L39	XGL2-15C-5-5	
		5-phase	CRK	CRK54*	42×42	AR	SFC-010DA2-5B-5B-L37	XGL2-15C-5-5
				RKS54*	42×42	AR	SFC-010DA2-5B-6B-L37	XGL2-15C-5-6
			PKP	PKP52*	28×28	AS	SFC-010DA2-5B-5B-L39	XGL2-15C-5-5
				PKP54*	42×42	AR	SFC-010DA2-5B-5B-L37	XGL2-15C-5-5
		2-phase	PKP/CVD	PKP22*	28×28	AS	SFC-010DA2-5B-5B-L39	XGL2-15C-5-5
				PKP24*	42×42	AR	SFC-010DA2-5B-5B-L37	XGL2-15C-5-5
		KEYENCE CORPORATION	2-phase	QS-M28	28×28	AS	SFC-010DA2-5B-5B-L39	XGL2-15C-5-5
				QS-M42	42×42	AR	SFC-010DA2-5B-5B-L37	XGL2-15C-5-5
		SANYO DENKI CO., LTD.	PB	PBDM28*	28×28	AS	SFC-010DA2-5B-5B-L39	XGL2-15C-5-5
				PBDM423, PBA**423	42×42	AR	SFC-010DA2-5B-6B-L37	XGL2-15C-5-6
	FAF/FDF52*			28×28	AS	SFC-010DA2-5B-5B-L39	XGL2-15C-5-5	
	FAF54*/FDF54*/FA511M42/FB511M42			42×42	AR	SFC-010DA2-5B-6B-L37	XGL2-15C-5-6	
	2-phase		D*14S28*	28×28	AS	SFC-010DA2-5B-5B-L39	XGL2-15C-5-5	
			DB14H52*	42×42	AR	SFC-010DA2-5B-5B-L37	XGT2-15C-5-5	
			DU15H52*					

Notes: 1. The table shows only a portion of the model numbers for motors. For details regarding model numbers, please see the catalog for each respective motor manufacturer.  
 2. If the maximum torque for motors exceeds the permissible input torque (p. 31), please consider a safety measure to limit the torque.  
 3. When installing a motor other than the motor model numbers listed above, contact THK.

Housing A

KR26
A0

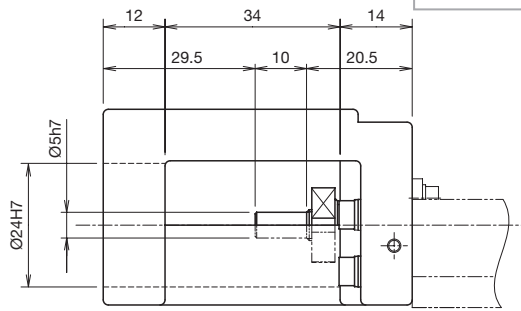
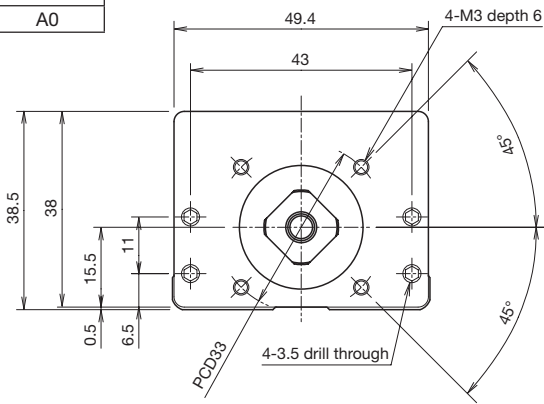

KR**	Actuator model
●◇	●: Housing A ◇: Intermediate flange

Intermediate Flange

KR26
AP

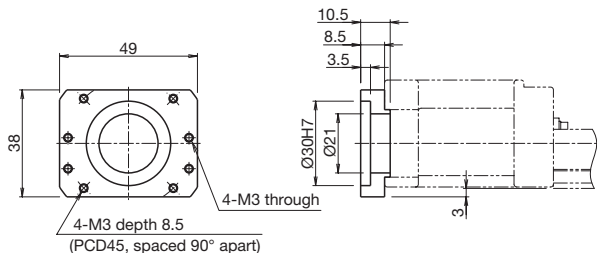

KR26
AQ

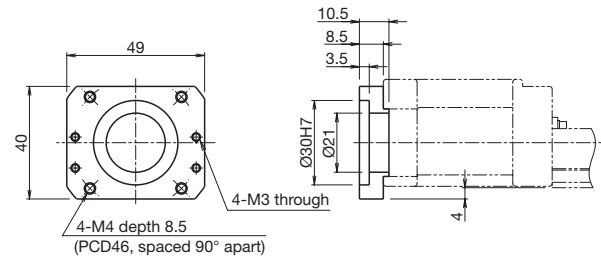

KR26
AR

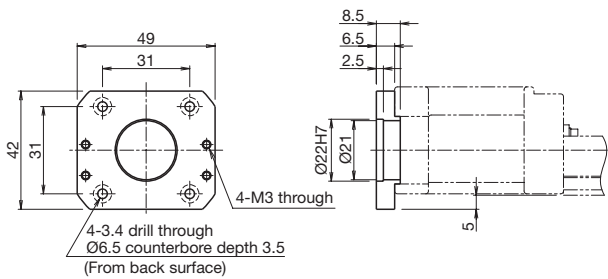

KR26
AS

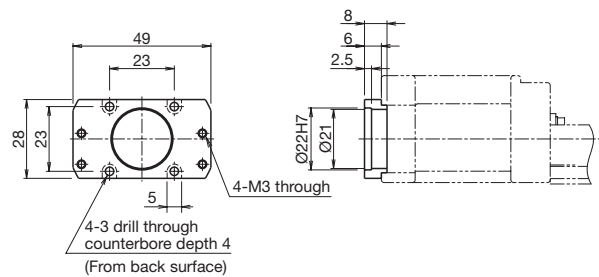

KR26
AN

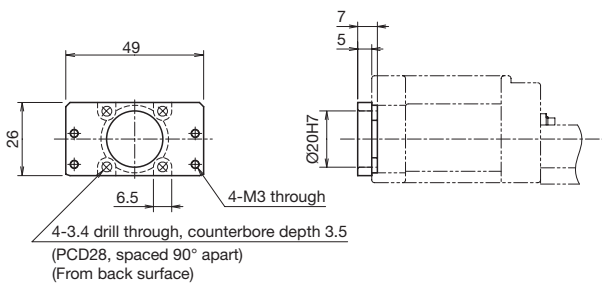

# Options

## Intermediate Flange (Motor Wrap)

Several types of intermediate flanges for mounting motors are available.

When selecting "R1," "R2," "R3," "R4," "R5," or "R6" for Model Number Coding ⑥ With/without motor, specify an intermediate flange that matches the motor used.

### Symbol Coding

Motor wrap symbol ①	Intermediate flange ②	Motor shaft diameter (mm) ③	Motor shaft securing method ④
W	Q	08	D
w	Refer to the Compatibility Table: Motors Used and Motor Wrap Symbols below.	Specify a motor shaft diameter. (Refer to the Compatibility Table: Motors Used and Motor Wrap Symbols below.)	K: Key D: D-cut

### Motor Shaft Securing Method

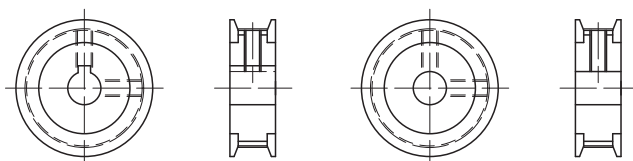

Key

D-cut

### Compatibility Table: Motors Used and Motor Wrap Symbols

Motor type	Manufacturer	Series	Motor model	Motor rated output (W)	Flange size	Housing A/Intermediate flange	
AC servo motor	YASKAWA Electric Corporation	Σ-Vmini	SGMMV-A1	10	25×25	WN-05D	
			SGMMV-A2	20			
			SGMMV-A3	30			
		Σ-V	SGMJV-A5	50	40×40	WQ-08K	
			SGMAV-A5				
		Σ-7	SGM7J-A5	50	40×40	WQ-08K	
			SGM7A-A5				
		Σ-X	SGMXJ-A5	50	40×40	WQ-08K	
	SGMXA-A5						
	Mitsubishi Electric Corporation	MELSERVO	J4	HG-AK0136	10	25×25	WN-05D
				HG-AK0236	20		
				HG-AK0336	30		
			J5	HG-KR053	50	40×40	WQ-08D
				HG-MR053			
				HK-KT053W			
	JN	HF-KN053	50	40×40	WQ-08D		
	TAMAGAWA SEIKI CO., LTD.	TBL-iii	TS4602	50	40×40	WQ-08D	
		TBL-iv	TSM3102				
	Panasonic Corporation	MINAS	A5	MSMD5A	50	38×38	WP-08D, WP-08K
				MSME5A			
A6			MSMF5A	50	38×38	WP-08K	
			MHMF5A		40×40	WQ-08K	
KEYENCE CORPORATION	SV	SV-M005	50	40×40	WQ-08K		
	SV2	SV2-M005					
SANYO DENKI CO., LTD.	SANMOTION R	R2□A04005	50	40×40	WQ-08K		
OMRON Corporation	OMNUC G5	R88M-K05030	50	40×40	WQ-08K		
FANUC CORPORATION	βis Series	βis0.2/5000	50	40×40	WQ-08K		

Notes: 1. The table shows only a portion of the model numbers for motors. For details regarding model numbers, please see the catalog for each respective motor manufacturer.  
 2. If the maximum torque for motors exceeds the permissible input torque (p. 31), please consider a safety measure to limit the torque.  
 3. When installing a motor other than the motor model numbers listed above, contact THK.

### Motor Wrap Housing A

KR26
20

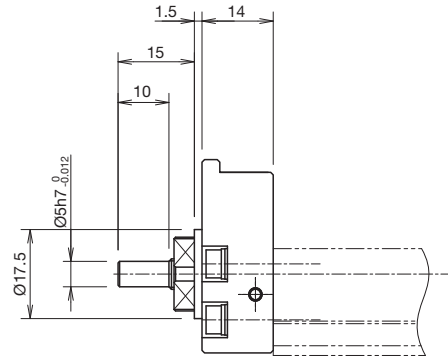
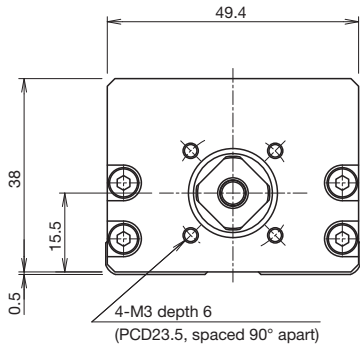

Note: The shaft end must be considered separately with motor wrap types. Contact THK for details.

KR**	Actuator model
●◇	●: Housing A ◇: Intermediate flange

### Motor Wrap Specification (Intermediate Flange)

KR26
WP

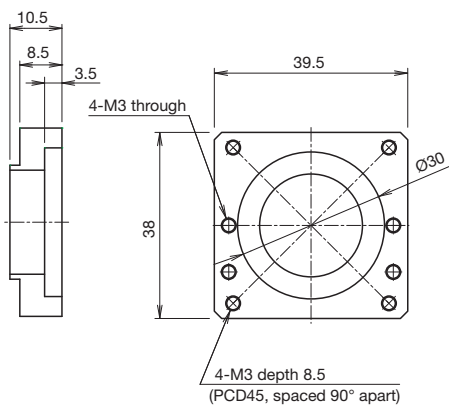

KR26
WQ

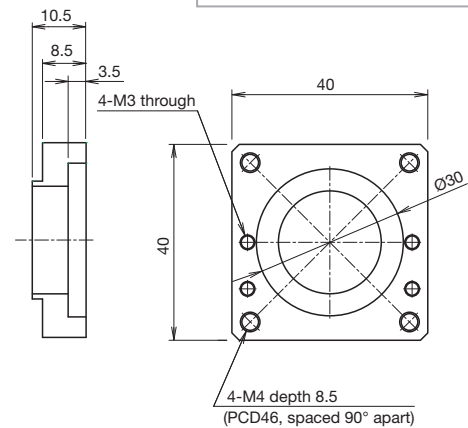

KR**	Actuator model
W□	□: Intermediate flange

KR26
WN

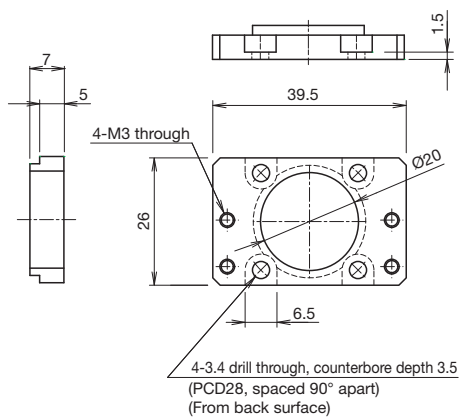

# KR30H A/B

Direct motor coupling	Motor wrap	Width 60 mm	Height 30 mm	Max. stroke 500 mm
-----------------------	------------	-------------	--------------	--------------------

## Model Number Coding

Model	Ball screw lead	Block type	Stroke	Accuracy grade	With/without motor	Cover	Sensors	Housing A/ Intermediate flange
①	②	③	④	⑤	⑥	⑦	⑧	⑨
KR30H	06	A	0050	P	0	1	2	AQ
<b>KR30H</b>	<b>05: 5 mm</b>	<b>A: x1</b>	<b>0050: 50 mm</b>	<b>No symbol: Normal grade</b>	<b>With direct coupling</b>	<b>0: Without cover</b>	<b>0</b>	<b>With direct coupling</b>
	<b>06: 6 mm</b>	<b>B: x2</b>	to	<b>H: High accuracy grade</b>	<b>0: Direct coupling (without motor)</b>	<b>1: With cover</b>	<b>1</b>	<b>A0</b>
	<b>10: 10 mm</b>		<b>0500: 500 mm</b>	<b>P: Precision grade</b>	<b>1: Direct coupling (THK will purchase and mount the motor you specify.)</b>	<b>2: With bellows</b>	<b>2</b>	<b>AP</b>
					<b>With motor wrap</b>		<b>6</b>	<b>AQ</b>
					<b>R1: Non-standard side wrap (without motor)</b>		<b>7</b>	<b>AR</b>
					<b>R2: Standard side wrap (without motor)</b>		<b>B</b>	<b>AT</b>
					<b>R3: Bottom side wrap (without motor)</b>		<b>E</b>	<b>AU</b>
					<b>R4: Non-standard side wrap (THK will purchase and mount the motor you specify.)</b>		<b>H</b>	<b>40</b>
					<b>R5: Standard side wrap (THK will purchase and mount the motor you specify.)</b>		<b>L</b>	<b>With motor wrap</b>
					<b>R6: Bottom side wrap (THK will purchase and mount the motor you specify.)</b>		<b>J</b>	<b>WP-08D</b>
							<b>M</b>	<b>WP-08K</b>
								<b>WP-08M</b>
							Sensor details → p. 55	<b>WQ-08D</b>
								<b>WQ-08K</b>
								<b>WQ-08M</b>
								<b>WQ-08M</b>

When selecting 2: With bellows for ⑦ Cover, specify the stroke with bellows.  
→ p. 165 to p. 166

When selecting "0":  
A coupling is not provided. Indicate when placing an order if a coupling is required.

When selecting "1," "R4," "R5," or "R6":  
The specified motor will be installed. Indicate the motor cable direction separately. Select ⑨ Intermediate flange to match the specified motor.

With direct coupling → p. 57  
With motor wrap → p. 59

### ③ Block Type

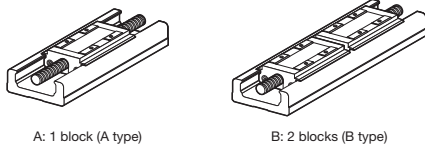

### ④ Motor Mounting Method

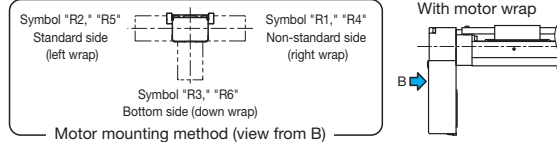

## Selection Information

### Basic Specifications

LM Guide	Basic dynamic load rating C (N)		14,800
	Basic static load rating C <sub>0</sub> (N)		22,900
	Radial clearance (mm)	Normal grade/High accuracy grade (H)	-0.004 to +0.002
		Precision grade (P)	-0.012 to -0.004
	Geometric moment of inertia	I <sub>x</sub> <sup>1</sup> (mm <sup>4</sup> )	2.7×10 <sup>4</sup>
I <sub>y</sub> <sup>2</sup> (mm <sup>4</sup> )		2.8×10 <sup>5</sup>	
Mass (kg/m)		5	
Ball screw	Ball screw lead (mm)		5   6   10
	Basic dynamic load rating C <sub>a</sub> (N)	Normal grade/High accuracy grade (H)	2,950   2,840   1,760
		Precision grade (P)	1,860   2,250   1,370
	Basic static load rating C <sub>0a</sub> (N)	Normal grade/High accuracy grade (H)	5,390   4,900   2,840
		Precision grade (P)	2,690   2,740   1,570
	Screw shaft diameter (mm)		Ø10
	Thread minor diameter (mm)		Ø7.8
	Ball center-to-center diameter (mm)		Ø10.5
Permissible rotational speed <sup>3</sup> (min <sup>-1</sup> )	Normal grade/High accuracy grade (H)	4,700	
	Precision grade (P)	6,000	
Bearing unit (fixed side)	Axial direction	Basic dynamic load rating C <sub>a</sub> (N)	1,790
		Static permissible load P <sub>0a</sub> (N)	2,590
Permissible input torque (N·m)	Direct coupling	1.2	
	Motor wrap	0.98	
Static permissible moment <sup>4,5</sup> (N·m)		M <sub>A</sub> : 166 (908), M <sub>B</sub> : 166 (908), M <sub>C</sub> : 428 (857)	
Service life <sup>6</sup> (km)		5,000   10,000	
Standard grease/Grease nipple used		THK AFB-LF Grease/PB107	

<sup>1</sup> I<sub>x</sub> is the geometric moment of inertia about the X axis.

<sup>2</sup> I<sub>y</sub> is the geometric moment of inertia about the Y axis.

<sup>3</sup> The permissible rotational speed may decrease as the stroke becomes longer.

<sup>4</sup> The value in parentheses is with 2 blocks (B type) attached.

<sup>5</sup> See p. 172 for the values if "1" or "2" is selected for item ⑦ in the Model Number Coding.

<sup>6</sup> Calculated under the following conditions.

Stroke: 300 mm (A type), 320 mm (B type) / Speed: 250 mm/s (for 5 mm lead), 300 mm/s (for 6 mm lead), 500 mm/s (for 10 mm lead) / Load mass: Maximum load capacity (p. 9) / Acceleration/deceleration: As when set to maximum load capacity (p. 9) / Center of gravity: Center of the table's upper surface.

Notes: 1. LM Guide load rating is the load rating per block.

2. Precision grade (P-grade) ball screws have integrated spacer balls with a 1:1 ratio.

### Accuracy

Accuracy grade	Item	Stroke <sup>7</sup>					
		50	100	200	300	400	500
Normal grade (no symbol)	Positioning repeatability (mm)	±0.01					
	Positioning accuracy (mm)	Not specified					
	Running parallelism (vertical direction) (mm)	Not specified					
	Backlash (mm)	0.02					
	Starting torque (N·cm)	7					

Accuracy grade	Item	Stroke <sup>7</sup>					
		50	100	200	300	400	500
High accuracy grade (H)	Positioning repeatability (mm)	±0.005					
	Positioning accuracy (mm)	0.06			0.08		
	Running parallelism (vertical direction) (mm)	0.02			0.03		
	Backlash (mm)	0.01					
	Starting torque (N·cm)	7					

Accuracy grade	Item	Stroke <sup>7</sup>					
		50	100	200	300	400	500
Precision grade (P)	Positioning repeatability (mm)	±0.003					
	Positioning accuracy (mm)	0.02			0.025		
	Running parallelism (vertical direction) (mm)	0.01			0.015		
	Backlash (mm)	0.003					
	Starting torque (N·cm)	15					

<sup>7</sup> Stroke with 1 block (A type).

Notes: 3. Precision evaluation in accordance with THK standards.

4. Measured using a motor for inspection. With motor wrap specifications, measurements are not made in the completed motor wrap state.

5. The starting torque represents the value when containing THK AFB-LF Grease.

6. The starting torque may exceed standards if using vacuum grease, clean room grease, or other high-viscosity greases, so care should be taken when selecting a motor.

7. Contact THK for accuracy higher than the standard stroke.

### Geometric Moment of Inertia

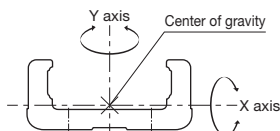

### Static Permissible Moment

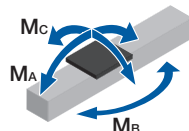

### Motor Selection Information

Stroke <sup>1</sup> (mm)	Outer rail length (mm)	LM Guide				Ball screw		Motor mounting part	
		Moving part mass (kg)			Sliding resistance value <sup>2</sup> (N)	Lead (mm)	Shaft length (mm)	Direct coupling	Motor wrap
		Block mass	Sub-table mass	Total mass				Shaft end diameter (mm)	Timing pulley (sum of two) Inertial moment x 10 <sup>-4</sup> (kg·m <sup>2</sup> )
50 to 500	150 to 600	A type: 0.4 B type: 0.8	A type: 0.2 B type: 0.4	A type: 0.6 B type: 1.2	3.5	5, 6, 10	191 to 641	Ø6h7	0.041

<sup>1</sup> Stroke with 1 block (A type).

<sup>2</sup> Value with 1 block (A type). This value is the sum of the rolling resistance value and seal resistance value.

Note: Refer to p. 57 for applicable couplings.

### Permissible Overhang Length<sup>3</sup>

Horizontal

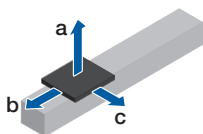

Wall-Mounted

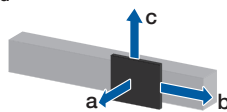

Vertical

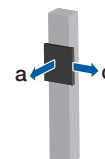

Estimated motor capacity 100 W	Ball screw lead (mm)	Load mass (kg)	a	b	c		
			(mm)	(mm)	(mm)		
Direct coupling	A type	5	8.5	450	140	200	
			17.5	200	60	100	
			35	90	30	50	
		6	8.5	450	140	200	
			17.5	200	60	100	
			35	90	30	50	
	10	7	550	140	250		
		14	260	70	120		
		28.5	110	30	60		
		B type	5	12	600	600	320
				24.5	600	290	160
				49	600	130	80
6	12		600	600	320		
	24.5		600	290	160		
	49		600	130	80		
10	9	600	600	430			
	18.5	600	300	210			
	37.5	600	140	100			

Estimated motor capacity 100 W	Ball screw lead (mm)	Load mass (kg)	a	b	c		
			(mm)	(mm)	(mm)		
Direct coupling	A type	5	7	220	150	530	
			14	90	60	250	
			28	30	20	120	
		6	7	220	170	590	
			14	90	80	290	
			28	30	30	140	
	10	5.5	290	170	600		
		11.5	120	80	360		
		23	40	30	180		
		B type	5	9.5	300	290	600
				19.5	130	140	480
				39.5	50	70	240
6	9.5		380	360	600		
	19.5		170	170	580		
	39.5		70	80	290		
10	8	460	420	600			
	16	210	210	600			
	32.5	90	100	350			

Estimated motor capacity 100 W	Ball screw lead (mm)	Load mass (kg)	a	c		
			(mm)	(mm)		
Direct coupling	A type	5	3.5	240	270	
			7	100	130	
			14.5	40	60	
		6	3.5	240	270	
			7.5	100	120	
			15	30	60	
	10	2	440	450		
		4.5	180	210		
		9	80	90		
		B type	5	3.5	600	600
				7	600	370
				14	510	180
6	3.5		600	600		
	7.5		600	350		
	15		470	170		
10	3	600	600			
	6	600	440			
	12.5	450	210			

<sup>3</sup> This is the value with the service life of the LM Guide limited to 5,000 km (for 5 or 6 mm lead) or 10,000 km (for 10 mm lead). The calculation conditions are as follows.  
Stroke: 275 mm (A type), 270 mm (B type) / Acceleration/deceleration: 0.3 G / Speed: 250 mm/s (for 5 mm lead), 300 mm/s (for 6 mm lead), 500 mm/s (for 10 mm lead) / Overhang direction:  
Loaded only in a single direction. Dimensions a, b, and c are from the center of the table's upper surface.

With Cover  
Direct Motor Coupling

Dimensions

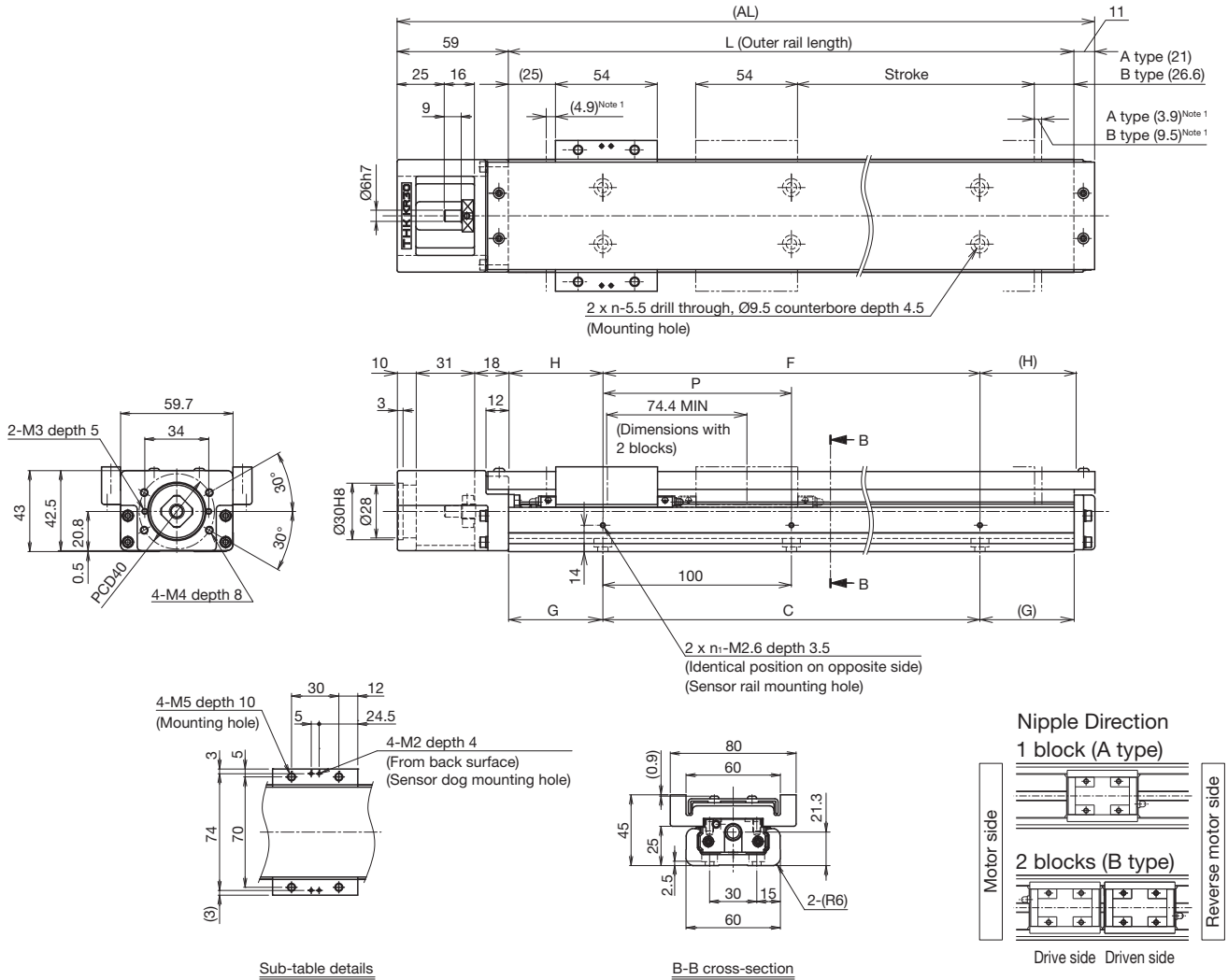

<sup>1</sup> Dimensions from the mechanical stopper to the stroke start position.

Stroke (mm) (Stroke between mechanical stoppers)	A type	50 (58.8)	100 (108.8)	200 (208.8)	300 (308.8)	400 (408.8)	500 (508.8)
		B type <sup>2</sup>	-	-	120 (134.4)	220 (234.4)	320 (334.4)
Maximum speed <sup>3</sup> (mm/s)	Ball screw lead: 5 mm	Normal grade/High accuracy grade			390	330	
		Precision grade			500	330	
	Ball screw lead: 6 mm	Normal grade/High accuracy grade			470	390	
		Precision grade			600	590	390
	Ball screw lead: 10 mm	Normal grade/High accuracy grade			790	650	
		Precision grade			1,000	980	650
Dimensions (mm)	AL	220	270	370	470	570	670
	L	150	200	300	400	500	600
	C	100	100	200	300	400	500
	G	25	50	50	50	50	50
	P	100	100	200	200	200	200
	F	100	100	200	200	400	400
	H	25	50	50	100	50	100
No. of mounting holes	n	2	2	3	4	5	6
	n <sub>1</sub>	2	2	2	2	3	3
Mass <sup>4</sup> (kg)		1.9	2.2	2.8	3.4	4	4.6

<sup>2</sup> The value with 2 blocks (B type) attached.

<sup>3</sup> The maximum speed is restricted by the actuator's permissible speed.

<sup>4</sup> The mass with 2 blocks (B type) has 0.6 kg added.

Without Cover  
Direct Motor Coupling

**Dimensions**

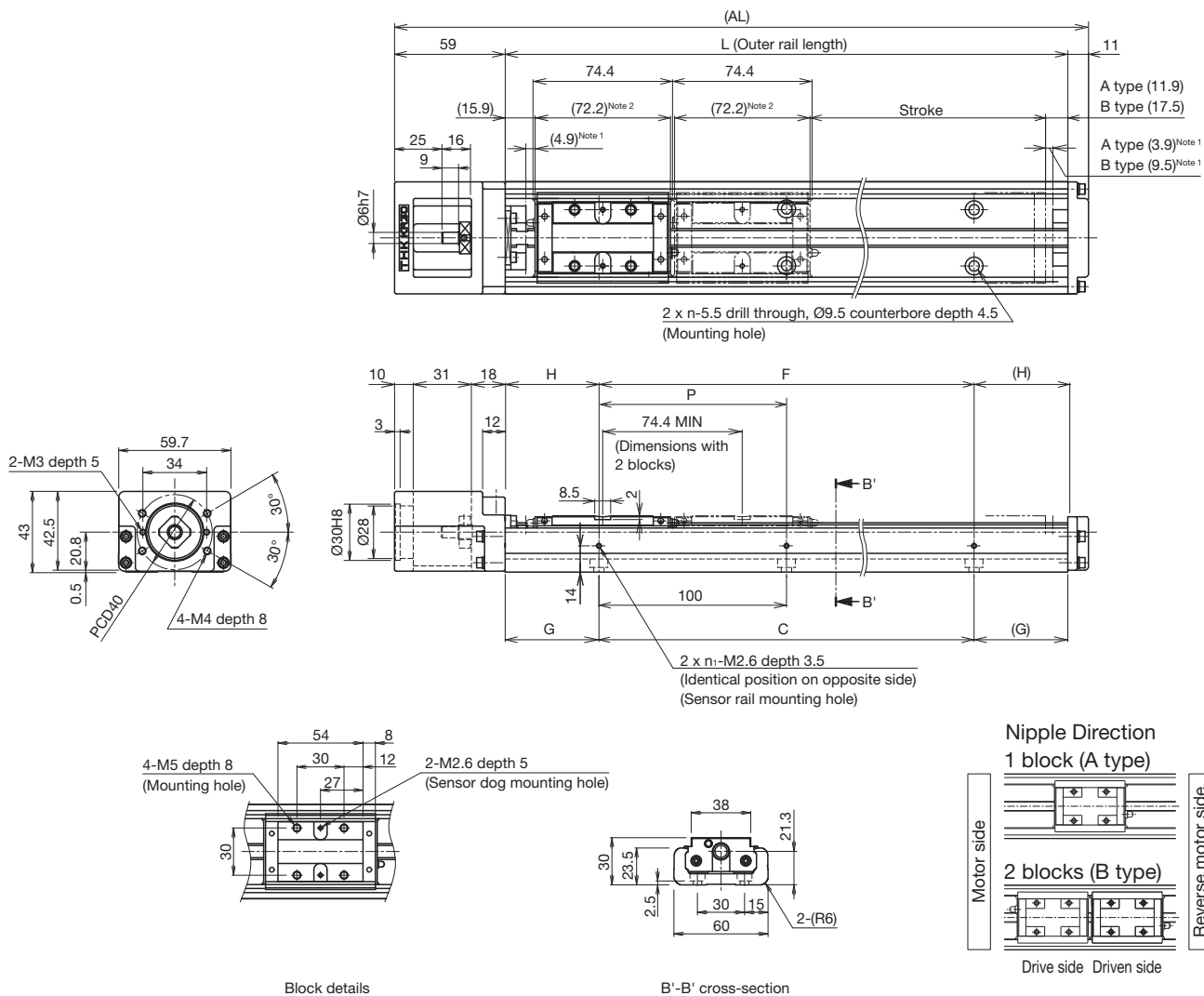

<sup>1</sup> Dimensions from the mechanical stopper to the stroke start position.  
<sup>2</sup> Shows the block length when calculating the enabled stroke range. 146.6 mm (2 blocks total) for KR30H with 2 blocks (B type).

Stroke (mm) (Stroke between mechanical stoppers)	A type	50 (58.8)	100 (108.8)	200 (208.8)	300 (308.8)	400 (408.8)	500 (508.8)	
	B type <sup>3</sup>	-	-	120 (134.4)	220 (234.4)	320 (334.4)	420 (434.4)	
Maximum speed <sup>4</sup> (mm/s)	Ball screw lead: 5 mm	Normal grade/High accuracy grade		390			330	
		Precision grade			500		330	
	Ball screw lead: 6 mm	Normal grade/High accuracy grade			470			390
		Precision grade		600			590	390
Ball screw lead: 10 mm	Normal grade/High accuracy grade			790			650	
	Precision grade		1,000			980	650	
Dimensions (mm)	AL	220	270	370	470	570	670	
	L	150	200	300	400	500	600	
	C	100	100	200	300	400	500	
	G	25	50	50	50	50	50	
	P	100	100	200	200	200	200	
	F	100	100	200	200	400	400	
	H	25	50	50	100	50	100	
No. of mounting holes	n	2	2	3	4	5	6	
	n <sub>1</sub>	2	2	2	2	3	3	
Mass <sup>5</sup> (kg)		1.6	1.9	2.5	3	3.6	4.2	

<sup>3</sup> The value with 2 blocks (B type) attached.  
<sup>4</sup> The maximum speed is restricted by the actuator's permissible speed.  
<sup>5</sup> The mass with 2 blocks (B type) has 0.4 kg added.

With Cover  
Motor Wrap

Dimensions

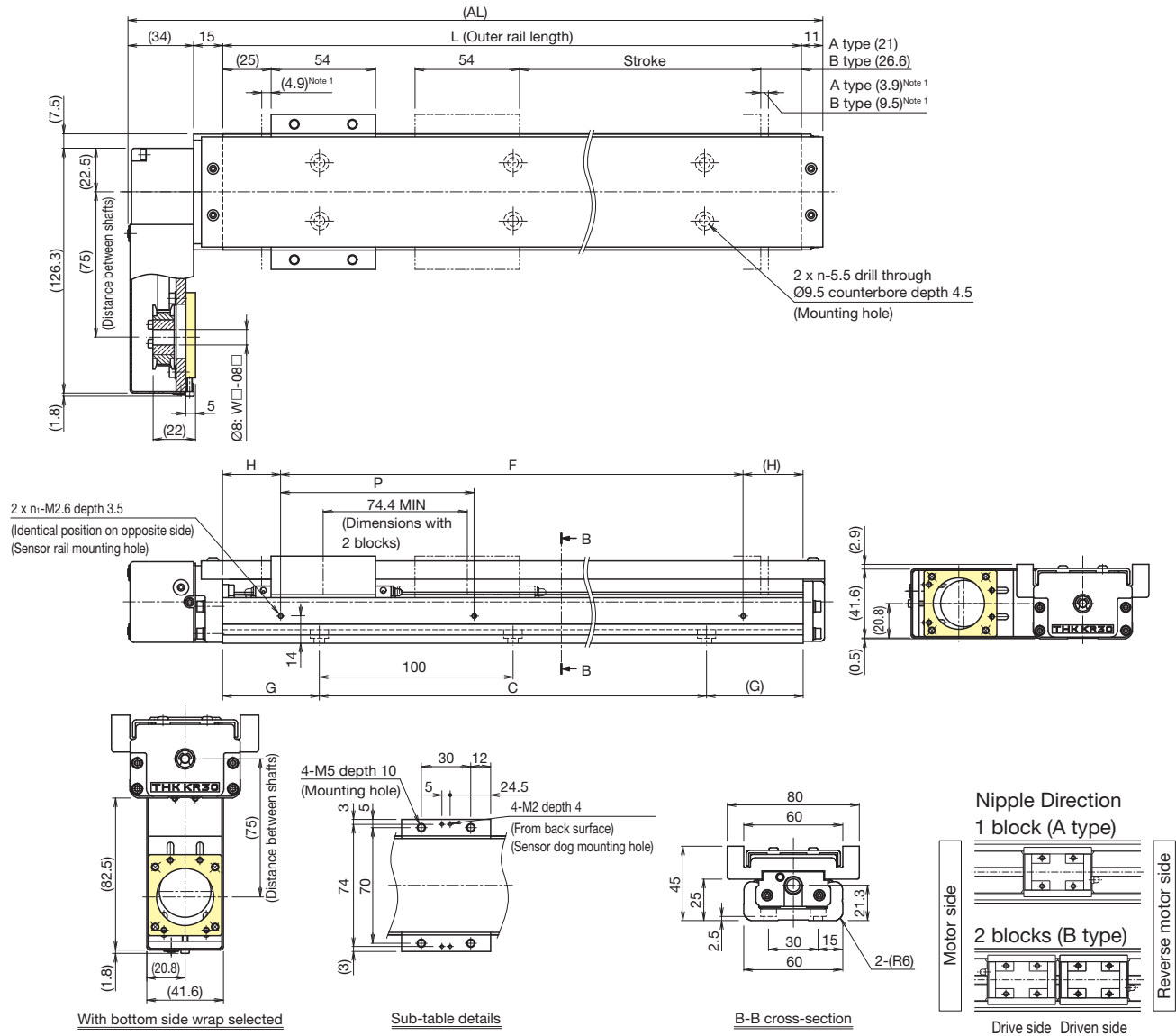

<sup>1</sup> Dimensions from the mechanical stopper to the stroke start position.

Stroke (mm) (Stroke between mechanical stoppers)	A type	50 (58.8)	100 (108.8)	200 (208.8)	300 (308.8)	400 (408.8)	500 (508.8)
	B type <sup>2</sup>	-	-	120 (134.4)	220 (234.4)	320 (334.4)	420 (434.4)
Maximum speed <sup>3</sup> (mm/s)	Ball screw lead: 5 mm			390			330
					500		330
	Ball screw lead: 6 mm			470			390
					600	590	390
	Ball screw lead: 10 mm			790			650
				1,000		980	650
Dimensions (mm)	AL	210	260	360	460	560	660
	L	150	200	300	400	500	600
	C	100	100	200	300	400	500
	G	25	50	50	50	50	50
	P	100	100	200	200	200	200
	F	100	100	200	200	400	400
No. of mounting holes	H	25	50	50	100	50	100
	n	2	2	3	4	5	6
	n <sub>1</sub>	2	2	2	2	3	3
	Mass <sup>4</sup> (kg)	2.2	2.5	3.1	3.7	4.4	5

<sup>2</sup> The value with 2 blocks (B type) attached.

<sup>3</sup> The maximum speed is restricted by the actuator's permissible speed.

<sup>4</sup> The mass with 2 blocks (B type) has 0.6 kg added.

Without Cover  
Motor Wrap

**Dimensions**

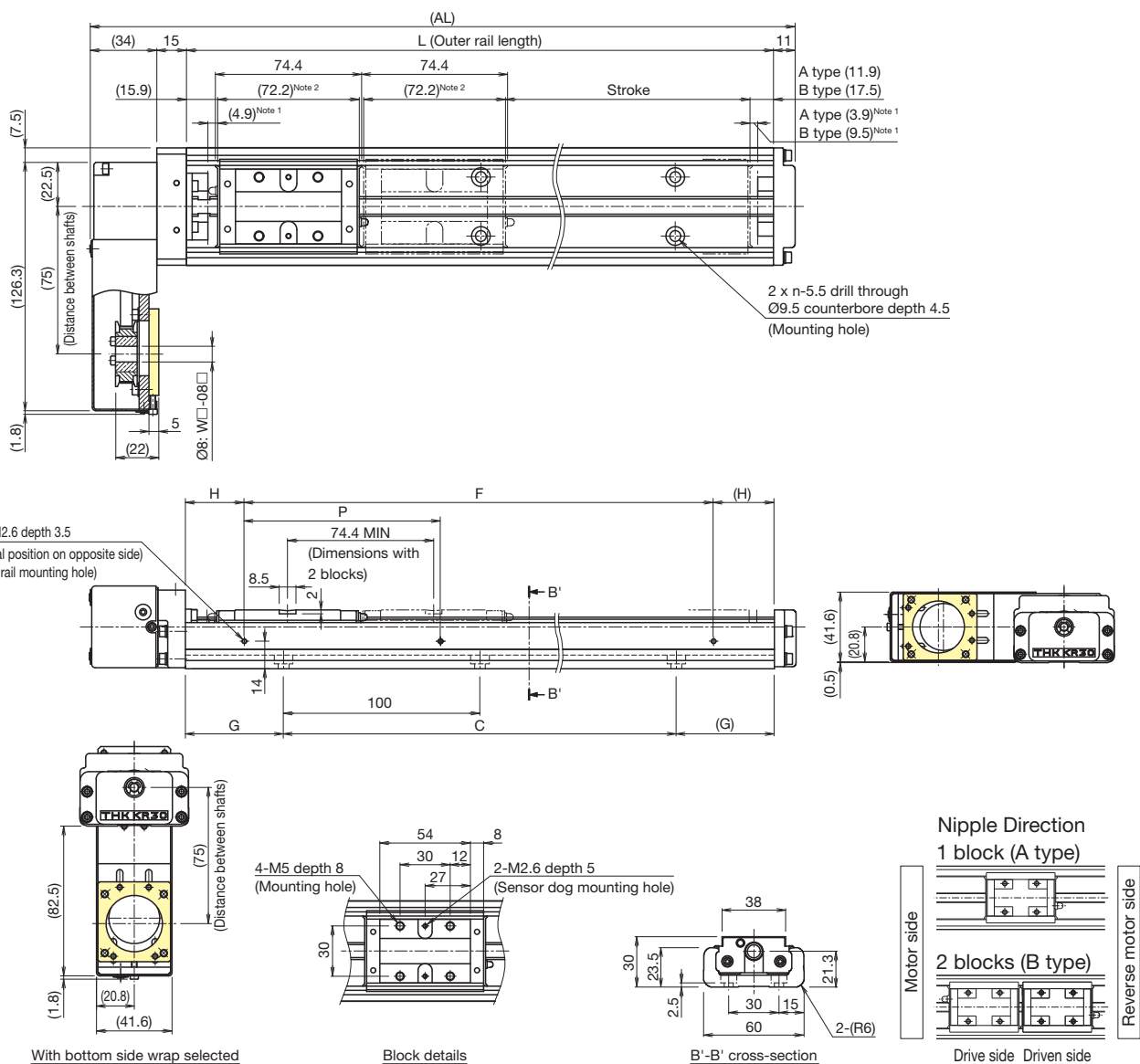

<sup>1</sup> Dimensions from the mechanical stopper to the stroke start position.  
<sup>2</sup> Shows the block length when calculating the enabled stroke range.  
146.6 mm (2 blocks total) for KR30H with 2 blocks (B type).

Stroke (mm) (Stroke between mechanical stoppers)	A type		50 (58.8)	100 (108.8)	200 (208.8)	300 (308.8)	400 (408.8)	500 (508.8)
	B type <sup>3</sup>		-	-	120 (134.4)	220 (234.4)	320 (334.4)	420 (434.4)
Maximum speed <sup>4</sup> (mm/s)	Ball screw lead: 5 mm	Normal grade/High accuracy grade	390			330		
		Precision grade	500			330		
	Ball screw lead: 6 mm	Normal grade/High accuracy grade	470			390		
		Precision grade	600			390		
Ball screw lead: 10 mm	Normal grade/High accuracy grade	790			650			
	Precision grade	1,000			650			
Dimensions (mm)	AL		210	260	360	460	560	660
	L		150	200	300	400	500	600
	C		100	100	200	300	400	500
	G		25	50	50	50	50	50
	P		100	100	200	200	200	200
	F		100	100	200	200	400	400
No. of mounting holes	n		2	2	3	4	5	6
	n <sub>1</sub>		2	2	2	2	3	3
Mass <sup>5</sup> (kg)			1.9	2.2	2.8	3.4	3.9	4.5

<sup>3</sup> The value with 2 blocks (B type) attached.  
<sup>4</sup> The maximum speed is restricted by the actuator's permissible speed.  
<sup>5</sup> The mass with 2 blocks (B type) has 0.4 kg added.

# KR30H C/D

Direct motor coupling

Motor wrap

Width 60 mm

Height 30 mm

Max. stroke 520 mm

## Model Number Coding

Model ①	Ball screw lead ②	Block type ③	Stroke ④	Accuracy grade ⑤	With/without motor ⑥	Cover ⑦	Sensors ⑧	Housing A/ Intermediate flange ⑨
KR30H	06	C	0070	P	0	1	2	AQ
<b>KR30H</b>	<b>05: 5 mm</b> <b>06: 6 mm</b> <b>10: 10 mm</b>	<b>C: x1</b> <b>D: x2</b>	<b>0020: 20 mm</b> to <b>0520: 520 mm</b>	<b>No symbol:</b> Normal grade <b>H:</b> High accuracy grade <b>P:</b> Precision grade	<b>0:</b> Direct coupling (without motor) <b>1:</b> Direct coupling (THK will purchase and mount the motor you specify.) <b>With motor wrap</b> <b>R1:</b> Non-standard side wrap (without motor) <b>R2:</b> Standard side wrap (without motor) <b>R3:</b> Bottom side wrap (without motor) <b>R4:</b> Non-standard side wrap (THK will purchase and mount the motor you specify.) <b>R5:</b> Standard side wrap (THK will purchase and mount the motor you specify.) <b>R6:</b> Bottom side wrap (THK will purchase and mount the motor you specify.)	<b>0:</b> Without cover <b>1:</b> With cover <b>2:</b> With bellows	<b>0</b> <b>1</b> <b>2</b> <b>6</b> <b>7</b> <b>B</b> <b>E</b> <b>H</b> <b>L</b> <b>J</b> <b>M</b>	<b>With direct coupling</b> <b>A0</b> <b>AP</b> <b>AQ</b> <b>AR</b> <b>AT</b> <b>AU</b> <b>40</b> <b>With motor wrap</b> <b>WP-08D</b> <b>WP-08K</b> <b>WP-08M</b> <b>WQ-08D</b> <b>WQ-08K</b> <b>WQ-08M</b>
			When selecting 2: With bellows for ⑦ Cover, specify the stroke with bellows. → p. 167 to p. 168		When selecting "0": A coupling is not provided. Indicate when placing an order if a coupling is required.		Sensor details → p. 55	
			When selecting "1," "R4," "R5," or "R6": The specified motor will be installed. Indicate the motor cable direction separately. Select ⑨ Intermediate flange to match the specified motor.				With direct coupling → p. 57 With motor wrap → p. 59	

### ③ BlockType

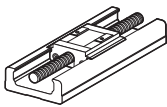

C: 1 short block (C type)

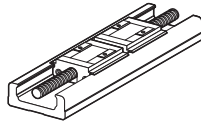

D: 2 short blocks (D type)

### ④ Motor Mounting Method

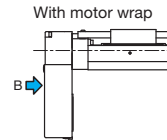
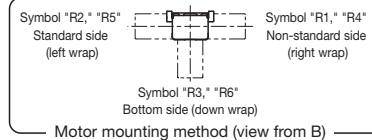

## Selection Information

### Basic Specifications

LM Guide	Basic dynamic load rating C (N)		9,500		
	Basic static load rating C <sub>0</sub> (N)		12,100		
	Radial clearance (mm)	Normal grade/High accuracy grade (H)	-0.004 to +0.002		
		Precision grade (P)	-0.012 to -0.004		
	Geometric moment of inertia	I <sub>x</sub> <sup>1</sup> (mm <sup>4</sup> )	2.7×10 <sup>4</sup>		
I <sub>y</sub> <sup>2</sup> (mm <sup>4</sup> )		2.8×10 <sup>5</sup>			
Mass (kg/m)		5			
Ball screw	Ball screw lead (mm)		5	6	10
	Basic dynamic load rating Ca (N)	Normal grade/High accuracy grade (H)	2,950	2,840	1,760
		Precision grade (P)	1,860	2,250	1,370
	Basic static load rating C <sub>0a</sub> (N)	Normal grade/High accuracy grade (H)	5,390	4,900	2,840
		Precision grade (P)	2,690	2,740	1,570
	Screw shaft diameter (mm)		Ø10		
	Thread minor diameter (mm)		Ø7.8		
	Ball center-to-center diameter (mm)		Ø10.5		
Permissible rotational speed <sup>3</sup> (min <sup>-1</sup> )	Normal grade/High accuracy grade (H)	4,700			
	Precision grade (P)	6,000			
Bearing unit (fixed side)	Axial direction	Basic dynamic load rating Ca (N)	1,790		
		Static permissible load P <sub>0a</sub> (N)	2,590		
Permissible input torque (N·m)	Direct coupling	1.2			
	Motor wrap	0.98			
Static permissible moment <sup>4,5</sup> (N·m)		M <sub>A</sub> : 44 (319), M <sub>B</sub> : 44 (319), M <sub>C</sub> : 214 (427)			
Service life <sup>6</sup> (km)		5,000	10,000		
Standard grease/Grease nipple used		THK AFB-LF Grease/PB107			

<sup>1</sup> I<sub>x</sub> is the geometric moment of inertia about the X axis.

<sup>2</sup> I<sub>y</sub> is the geometric moment of inertia about the Y axis.

<sup>3</sup> The permissible rotational speed may decrease as the stroke becomes longer.

<sup>4</sup> The value in parentheses is with 2 short blocks (D type) attached.

<sup>5</sup> See p. 172 for the values if "1" or "2" is selected for item ⑦ in the Model Number Coding.

<sup>6</sup> Calculated under the following conditions.

Stroke: 320 mm (C type), 270 mm (D type) / Speed: 250 mm (for 5 mm lead), 300 mm/s (for 6 mm lead), 500 mm/s (for 10 mm lead) / Load mass: Maximum load capacity (p. 9) / Acceleration/deceleration: As when set to maximum load capacity (p. 9) / Center of gravity: Center of the table's upper surface.

Notes: 1. LM Guide load rating is the load rating per short block.

2. Precision grade (P-grade) ball screws have integrated spacer balls with a 1:1 ratio.

### Accuracy

Accuracy grade	Item	Stroke <sup>7</sup>					
		70	120	220	320	420	520
Normal grade (no symbol)	Positioning repeatability (mm)	±0.01					
	Positioning accuracy (mm)	Not specified					
	Running parallelism (vertical direction) (mm)	Not specified					
	Backlash (mm)	0.02					
	Starting torque (N·cm)	7					

Accuracy grade	Item	Stroke <sup>7</sup>					
		70	120	220	320	420	520
High accuracy grade (H)	Positioning repeatability (mm)	±0.005					
	Positioning accuracy (mm)	0.06		0.08			
	Running parallelism (vertical direction) (mm)	0.02		0.03			
	Backlash (mm)	0.01					
	Starting torque (N·cm)	7					

Accuracy grade	Item	Stroke <sup>7</sup>					
		70	120	220	320	420	520
Precision grade (P)	Positioning repeatability (mm)	±0.003					
	Positioning accuracy (mm)	0.02		0.025			
	Running parallelism (vertical direction) (mm)	0.01		0.015			
	Backlash (mm)	0.003					
	Starting torque (N·cm)	15					

<sup>7</sup> Stroke with 1 short block (C type).

Notes: 3. Precision evaluation in accordance with THK standards.

4. Measured using a motor for inspection. With motor wrap specifications, measurements are not made in the completed motor wrap state.

5. The starting torque represents the value when containing THK AFB-LF Grease.

6. The starting torque may exceed standards if using vacuum grease, clean room grease, or other high-viscosity greases, so care should be taken when selecting a motor.

7. Contact THK for accuracy higher than the standard stroke.

### Geometric Moment of Inertia

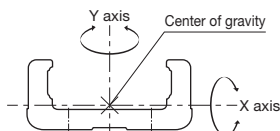

### Static Permissible Moment

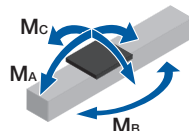

### Motor Selection Information

Stroke <sup>1</sup> (mm)	Outer rail length (mm)	LM Guide				Ball screw		Motor mounting part	
		Moving part mass (kg)			Sliding resistance value <sup>2</sup> (N)	Lead (mm)	Shaft length (mm)	Direct coupling	Motor wrap
		Block mass	Sub-table mass	Total mass				Shaft end diameter (mm)	Timing pulley (sum of two) Inertial moment x 10 <sup>-4</sup> (kg·m <sup>2</sup> )
70 to 520	150 to 600	C type: 0.2 D type: 0.4	C type: 0.1 D type: 0.2	C type: 0.3 D type: 0.6	3.2	5, 6, 10	191 to 641	Ø6h7	0.041

<sup>1</sup> Stroke with 1 short block (C type).

<sup>2</sup> Value with 1 short block (C type). This value is the sum of the rolling resistance value and seal resistance value.

Note: Refer to p. 57 for applicable couplings.

### Permissible Overhang Length<sup>3</sup>

Horizontal

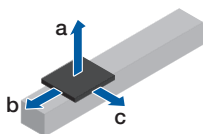

Wall-Mounted

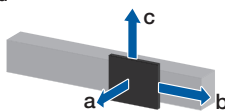

Vertical

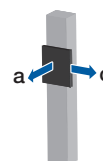

Estimated motor capacity 100 W		Ball screw lead (mm)	Load mass (kg)	a (mm)	b (mm)	c (mm)	
Direct coupling	C type	5	6	180	40	120	
			12.5	70	20	60	
			25	20	0	30	
		6	6	180	40	120	
			12.5	70	20	60	
			25	20	0	30	
	10	3	390	70	250		
		6.5	160	30	110		
		13	70	10	50		
		D type	5	8.5	600	240	230
				17.5	580	110	110
				35.5	270	50	50
6	8.5		600	240	230		
	17.5		580	110	110		
	35.5		270	50	50		
10	7	600	230	280			
	14.5	600	100	130			
	29	300	40	60			

Estimated motor capacity 100 W		Ball screw lead (mm)	Load mass (kg)	a (mm)	b (mm)	c (mm)	
Direct coupling	C type	5	3.5	180	70	420	
			7	70	30	210	
			14.5	20	10	100	
		6	3.5	180	70	420	
			7	70	30	210	
			14.5	20	10	100	
	10	2	350	90	600		
		4.5	140	40	280		
		9.5	50	10	110		
		D type	5	7	250	200	600
				14	110	100	330
				28.5	30	40	160
6	7		250	200	600		
	14		110	100	330		
	28.5		30	40	160		
10	5.5	320	250	600			
	11	140	120	420			
	22.5	50	40	200			

Estimated motor capacity 100 W		Ball screw lead (mm)	Load mass (kg)	a (mm)	c (mm)	
Direct coupling	C type	5	1	250	250	
			2	110	110	
			4.5	40	40	
		6	1	250	250	
			2	110	110	
			4.5	40	40	
	10	0.5	250	250		
		1.5	110	110		
		3.5	40	40		
		D type	5	3.5	580	300
				7	280	150
				14.5	120	70
6	3.5		560	300		
	7.5		270	140		
	15		120	70		
10	2	600	540			
	4.5	350	240			
	9	160	120			

<sup>3</sup> This is the value with the service life of the LM Guide limited to 5,000 km (for 5 or 6 mm lead) or 10,000 km (for 10 mm lead). The calculation conditions are as follows.  
Stroke: 295 mm (C type), 245 mm (D type) / Acceleration/deceleration: 0.3 G / Speed: 250 mm/s (for 5 mm lead), 300 mm/s (for 6 mm lead), 500 mm/s (for 10 mm lead) / Overhang direction:  
Loaded only in a single direction. Dimensions a, b, and c are from the center of the table's upper surface.

With Cover  
Direct Motor Coupling

Dimensions

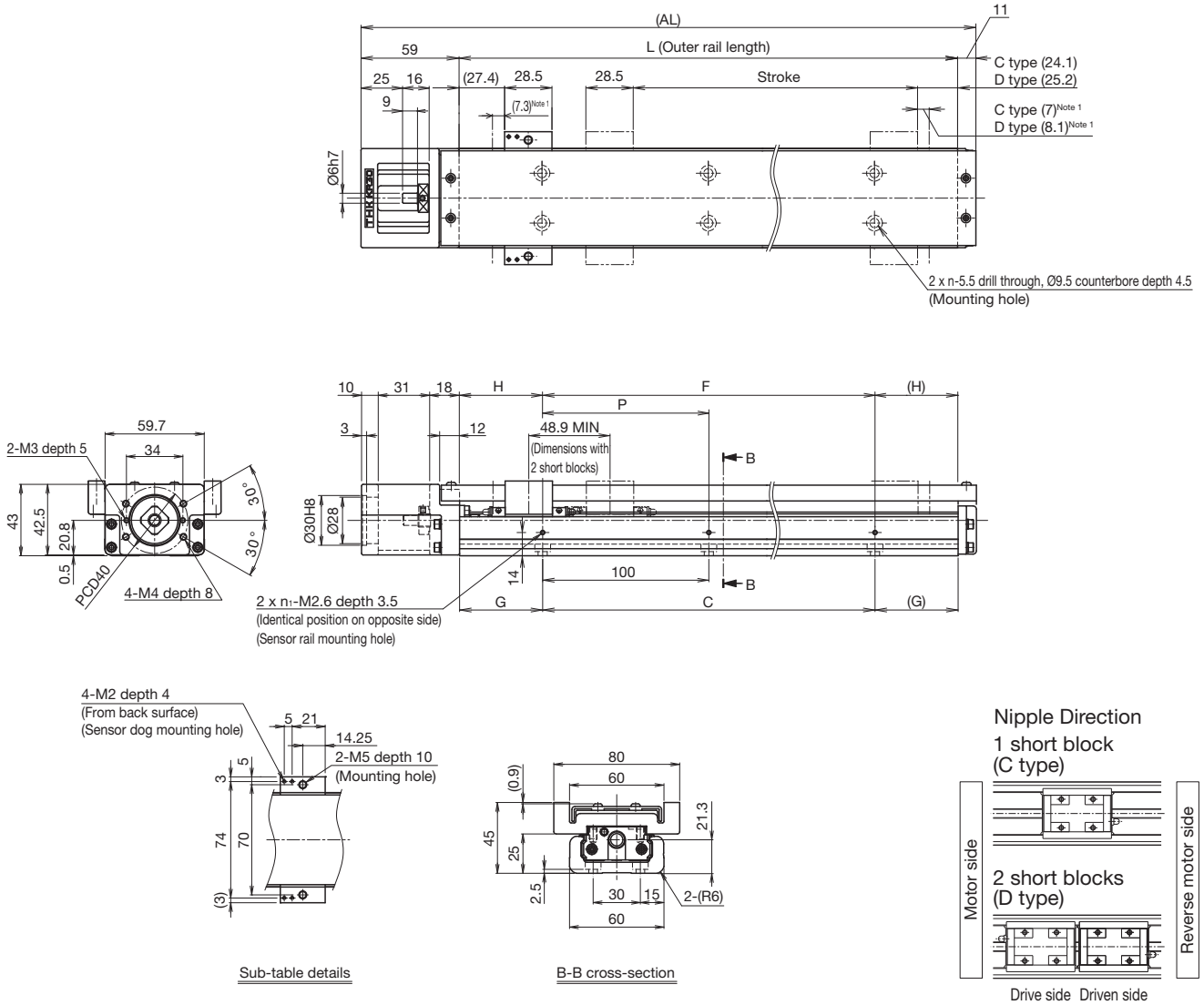

<sup>1</sup> Dimensions from the mechanical stopper to the stroke start position.

Stroke (mm) (Stroke between mechanical stoppers)	C type		70 (84.3)	120 (134.3)	220 (234.3)	320 (334.3)	420 (434.3)	520 (534.3)
	D type <sup>2</sup>		20 (35.4)	70 (85.4)	170 (185.4)	270 (285.4)	370 (385.4)	470 (485.4)
Maximum speed <sup>3</sup> (mm/s)	Ball screw lead: 5 mm	Normal grade/High accuracy grade	390				450	300
		Precision grade	500				450	300
	Ball screw lead: 6 mm	Normal grade/High accuracy grade	470				530	360
		Precision grade	600				530	360
Ball screw lead: 10 mm	Normal grade/High accuracy grade	790				880	600	
	Precision grade	1,000				880	600	
Dimensions (mm)	AL	220	270	370	470	570	670	
	L	150	200	300	400	500	600	
	C	100	100	200	300	400	500	
	G	25	50	50	50	50	50	
	P	100	100	200	200	200	200	
	F	100	100	200	200	400	400	
	H	25	50	50	100	50	100	
No. of mounting holes	n	2	2	3	4	5	6	
	n <sub>1</sub>	2	2	2	2	3	3	
Mass <sup>4</sup> (kg)		1.6	1.9	2.5	3.1	3.7	4.3	

<sup>2</sup> The value with 2 short blocks (D type) attached.

<sup>3</sup> The maximum speed is restricted by the actuator's permissible speed.

<sup>4</sup> The mass with 2 short blocks (D type) has 0.3 kg added.

Without Cover  
Direct Motor Coupling

Dimensions

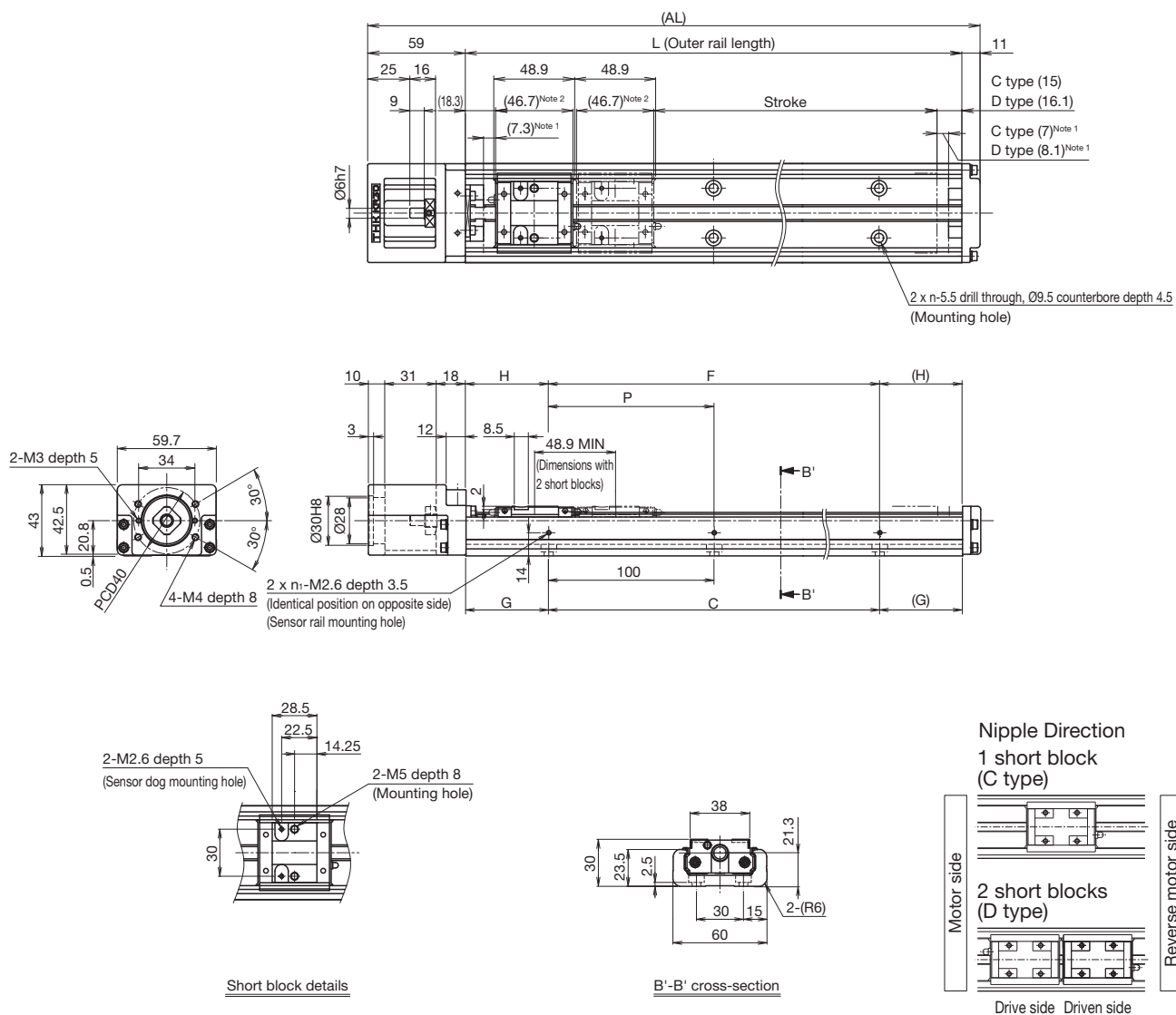

<sup>1</sup> Dimensions from the mechanical stopper to the stroke start position.  
<sup>2</sup> Shows the short block length when calculating the enabled stroke range. 95.6 mm (2 blocks total) for KR30H with 2 short blocks (D type).

Stroke (mm) (Stroke between mechanical stoppers)	C type	70 (84.3)	120 (134.3)	220 (234.3)	320 (334.3)	420 (434.3)	520 (534.3)	
	D type <sup>3</sup>	20 (35.4)	70 (85.4)	170 (185.4)	270 (285.4)	370 (385.4)	470 (485.4)	
Maximum speed <sup>4</sup> (mm/s)	Ball screw lead: 5 mm	Normal grade/High accuracy grade	390				300	300
		Precision grade	500				450	300
	Ball screw lead: 6 mm	Normal grade/High accuracy grade	470					360
		Precision grade	600				530	360
	Ball screw lead: 10 mm	Normal grade/High accuracy grade	790					600
		Precision grade	1,000				880	600
Dimensions (mm)	AL	220	270	370	470	570	670	
	L	150	200	300	400	500	600	
	C	100	100	200	300	400	500	
	G	25	50	50	50	50	50	
	P	100	100	200	200	200	200	
	F	100	100	200	200	400	400	
	H	25	50	50	100	50	100	
No. of mounting holes	n	2	2	3	4	5	6	
	n <sub>1</sub>	2	2	2	2	3	3	
Mass <sup>5</sup> (kg)		1.4	1.7	2.3	2.8	3.4	4	

<sup>3</sup> The value with 2 short blocks (D type) attached.  
<sup>4</sup> The maximum speed is restricted by the actuator's permissible speed.  
<sup>5</sup> The mass with 2 short blocks (D type) has 0.2 kg added.

With Cover  
Motor Wrap

Dimensions

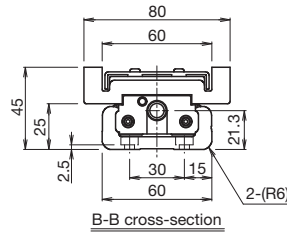
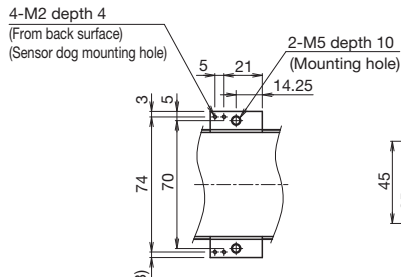
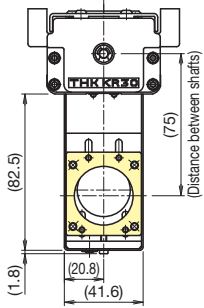
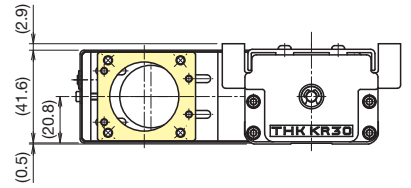
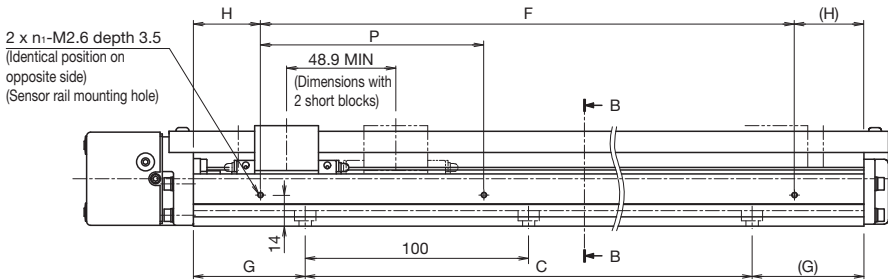
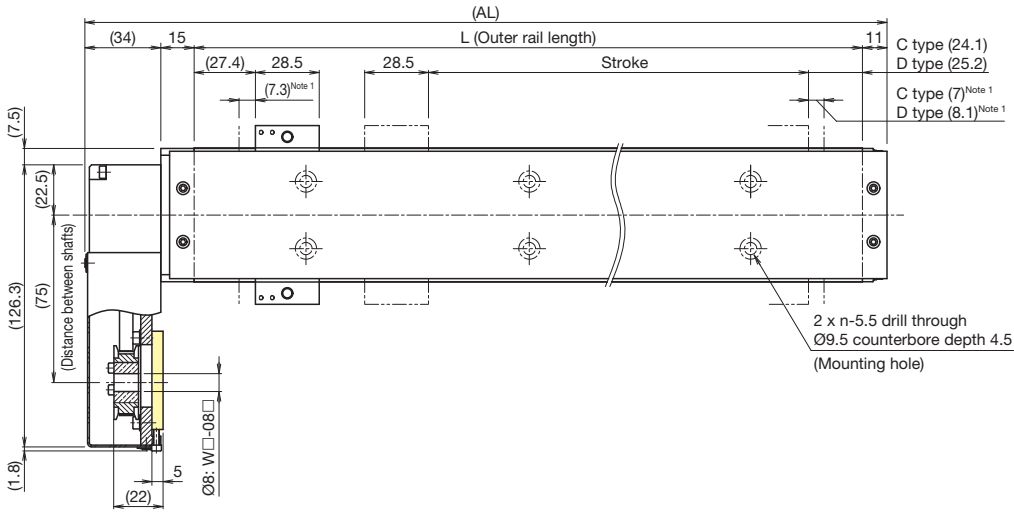

Nipple Direction  
1 short block  
(C type)

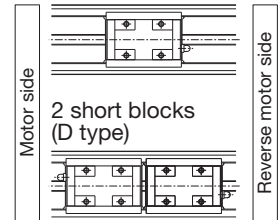

Drive side Driven side

<sup>1</sup> Dimensions from the mechanical stopper to the stroke start position.

Stroke (mm) (Stroke between mechanical stoppers)	C type	70 (84.3)	120 (134.3)	220 (234.3)	320 (334.3)	420 (434.3)	520 (534.3)
	D type <sup>2</sup>	20 (35.4)	70 (85.4)	170 (185.4)	270 (285.4)	370 (385.4)	470 (485.4)
Maximum speed <sup>3</sup> (mm/s)	Ball screw lead: 5 mm			390		450	300
					500		300
	Ball screw lead: 6 mm			470		530	360
				600			360
	Ball screw lead: 10 mm			790		880	600
				1,000			600
Dimensions (mm)	AL	210	260	360	460	560	660
	L	150	200	300	400	500	600
	C	100	100	200	300	400	500
	G	25	50	50	50	50	50
	P	100	100	200	200	200	200
	F	100	100	200	200	400	400
No. of mounting holes	H	25	50	50	100	50	100
	n	2	2	3	4	5	6
	n <sub>1</sub>	2	2	2	2	3	3
	Mass <sup>4</sup> (kg)	1.9	2.2	2.8	3.4	4.1	4.7

<sup>2</sup> The value with 2 short blocks (D type) attached.

<sup>3</sup> The maximum speed is restricted by the actuator's permissible speed.

<sup>4</sup> The mass with 2 short blocks (D type) has 0.3 kg added.

Without Cover  
Motor Wrap

Dimensions

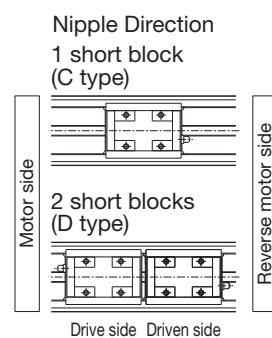
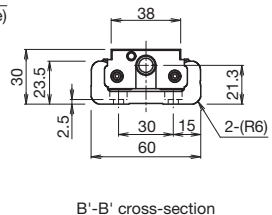
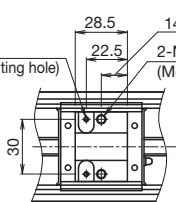
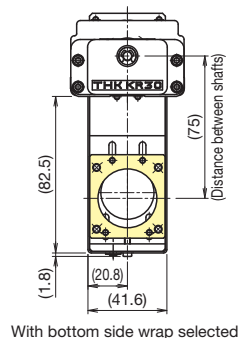
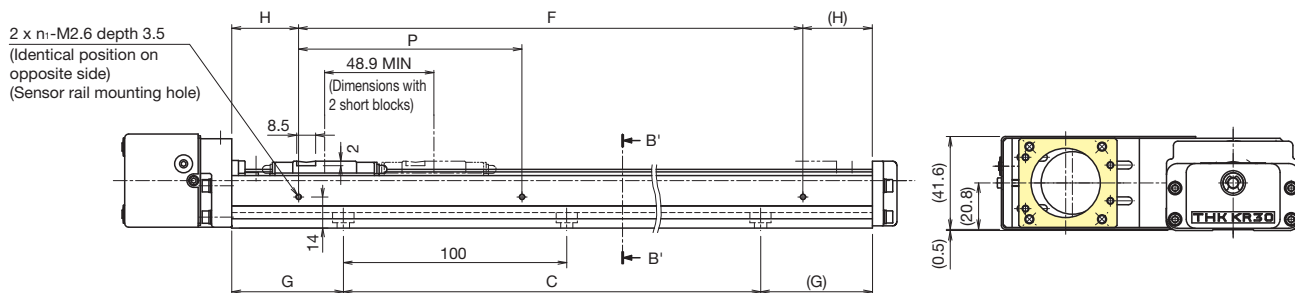
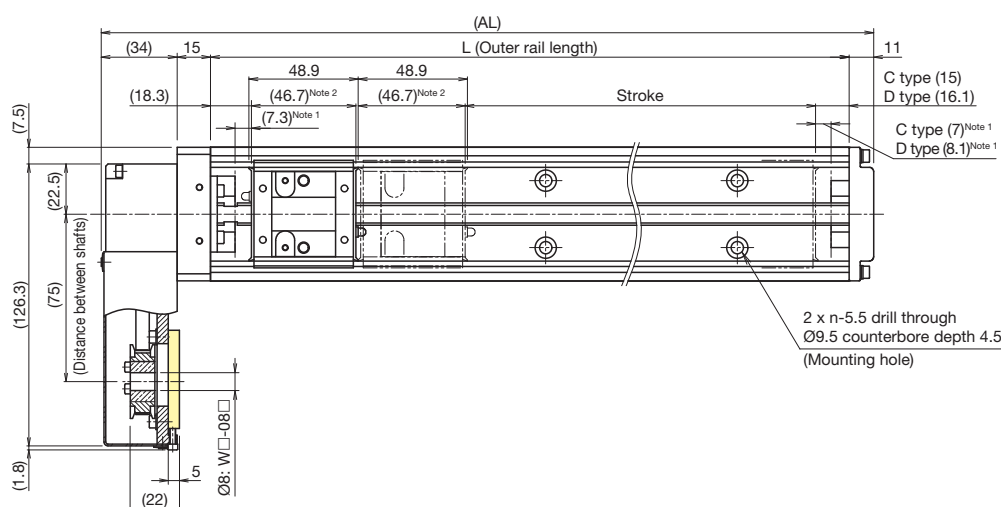

<sup>1</sup> Dimensions from the mechanical stopper to the stroke start position.  
<sup>2</sup> Shows the short block length when calculating the enabled stroke range. 95.6 mm (2 blocks total) for KR30H with 2 short blocks (D type).

Stroke (mm) (Stroke between mechanical stoppers)	C type	70 (84.3)	120 (134.3)	220 (234.3)	320 (334.3)	420 (434.3)	520 (534.3)	
	D type <sup>3</sup>	20 (35.4)	70 (85.4)	170 (185.4)	270 (285.4)	370 (385.4)	470 (485.4)	
Maximum speed <sup>4</sup> (mm/s)	Ball screw lead: 5 mm	Normal grade/High accuracy grade	390				300	300
		Precision grade	500				450	360
	Ball screw lead: 6 mm	Normal grade/High accuracy grade	470				360	360
		Precision grade	600				530	600
Ball screw lead: 10 mm	Normal grade/High accuracy grade	790				600	600	
	Precision grade	1,000				880	600	
Dimensions (mm)	AL	210	260	360	460	560	660	
	L	150	200	300	400	500	600	
	C	100	100	200	300	400	500	
	G	25	50	50	50	50	50	
	P	100	100	200	200	200	200	
	F	100	100	200	200	400	400	
No. of mounting holes	n	2	2	3	4	5	6	
	n <sub>1</sub>	2	2	2	2	3	3	
Mass <sup>5</sup> (kg)		1.7	2	2.6	3.2	3.7	4.3	

<sup>3</sup> The value with 2 short blocks (D type) attached.  
<sup>4</sup> The maximum speed is restricted by the actuator's permissible speed.  
<sup>5</sup> The mass with 2 short blocks (D type) has 0.2 kg added.

# Options

## Sensors

Optional photo sensors and proximity sensors are available. Sensor-equipped models also feature a dedicated sensor rail and sensor dog.

Sensors, sensor rails, and sensor dogs can be mounted on both sides when the stroke is less than 70 mm.

Mounting example

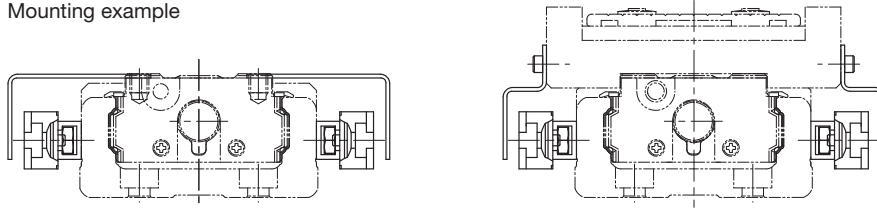

Symbol	Description	Model	Accessories
0	None	-	-
1	With sensor rail	-	Mounting screws, sensor rail (x1 or 2)
2	Photo sensor <sup>1</sup> (x3)	EE-SX671 (OMRON Corporation)	Mounting screws, nuts, sensor dog (x1 or 2), sensor rail (x1 or 2), mounting plates (x3), connectors (EE-1001 x3)
6	Photo sensor <sup>1</sup> (x3)	EE-SX674 (OMRON Corporation)	Mounting screws, nuts, sensor dog (x1 or 2), sensor rail (x1 or 2), mounting plates (x3), connectors (EE-1001 x3)
7	Proximity sensor N.O. contact <sup>2</sup> (x3)	APM-D3A1-001 (Azbil Corporation)	Mounting screws, nuts, sensor dog (x1 or 2), sensor rail (x1 or 2)
B	Proximity sensor N.C. contact <sup>3</sup> (x3)	APM-D3B1-003 (Azbil Corporation)	Mounting screws, nuts, sensor dog (x1 or 2), sensor rail (x1 or 2)
E	Proximity sensor N.O. contact <sup>2</sup> (x1) N.C. contact <sup>3</sup> (x2)	APM-D3A1-001 (Azbil Corporation) APM-D3B1-003 (Azbil Corporation)	Mounting screws, nuts, sensor dog (x1 or 2), sensor rail (x1 or 2)
H	Proximity sensor N.O. contact <sup>2</sup> (x3)	GX-F12A (Panasonic Industry Co., Ltd.)	Mounting screws, nuts, sensor dog (x1 or 2), sensor rail (x1 or 2)
L	Proximity sensor N.C. contact <sup>3</sup> (x3)	GX-F12B (Panasonic Industry Co., Ltd.)	Mounting screws, nuts, sensor dog (x1 or 2), sensor rail (x1 or 2)
J	Proximity sensor N.O. contact <sup>2</sup> (x1) N.C. contact <sup>3</sup> (x2)	GX-F12A (Panasonic Industry Co., Ltd.) GX-F12B (Panasonic Industry Co., Ltd.)	Mounting screws, nuts, sensor dog (x1 or 2), sensor rail (x1 or 2)
M	Proximity sensor N.O. contact <sup>2</sup> (x1) (PNP output) N.C. contact <sup>3</sup> (x2) (PNP output)	GX-F12A-P (Panasonic Industry Co., Ltd.) GX-F12B-P (Panasonic Industry Co., Ltd.)	Mounting screws, nuts, sensor dog (x1 or 2), sensor rail (x1 or 2)

<sup>1</sup> The photo sensors can be switched between ON when lit and ON when unlit.

<sup>2</sup> N.O. contact: Normally open contact point

<sup>3</sup> N.C. contact: Normally closed contact point

Notes: 1. If proximity sensors are close to one another, they may not function properly. If that happens, please prepare a type with a different frequency.

2. Mounting of sensors other than those in the table above is possible. Contact THK for details.

## Sensor Rail Mounting Dimensions

Mounting only a sensor rail is also possible.

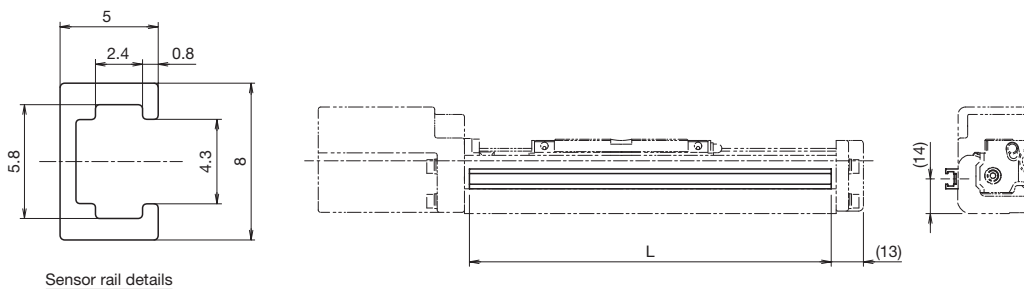

Sensor rail details

Stroke <sup>4</sup> (mm)	Outer rail length (mm)	L (mm)
50	150	146
100	200	196
200	300	296
300	400	396
400	500	496
500	600	596

<sup>4</sup> Stroke with 1 block (A type).

### Photo Sensor Mounting Dimensions

Connector: EE-1001 (OMRON Corporation) x3 included.  
To be mounted by the customer.

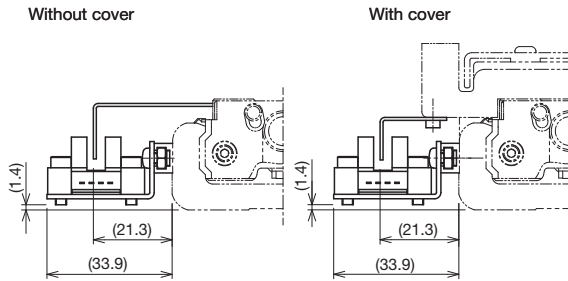

Symbol	Model	Manufacturer
2	EE-SX671	OMRON Corporation

Sensor dog width (without cover): 8.5 mm  
Sensor dog width (with cover): 10 mm

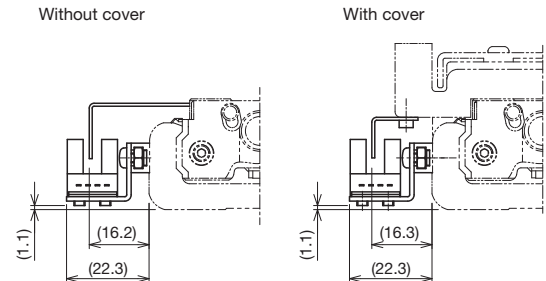

Symbol	Model	Manufacturer
6	EE-SX674	OMRON Corporation

Sensor dog width (without cover): 8.5 mm  
Sensor dog width (with cover): 10 mm

### Proximity Sensor Mounting Dimensions

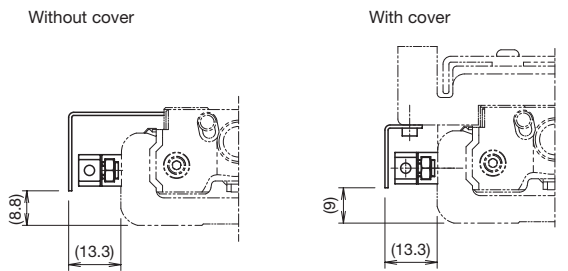

Symbol	Model	Manufacturer
7, B, E	APM-D3A1-001	Azbil Corporation
	APM-D3B1-003	

Sensor dog width (without cover): 8.5 mm  
Sensor dog width (with cover): 10 mm

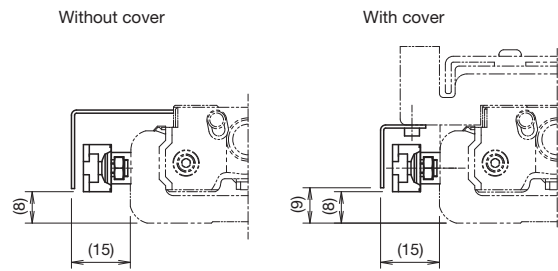

Symbol	Model	Manufacturer
H, L, J	GX-F12A	Panasonic Industry Co., Ltd.
	GX-F12B	
M	GX-F12A-P	
	GX-F12B-P	

Sensor dog width (without cover): 8.5 mm  
Sensor dog width (with cover): 10 mm

# Options

## Intermediate Flange (Direct Coupling)

Several types of intermediate flanges for mounting motors are available.

When selecting "0" or "1" for Model Number Coding ⑥ With/without motor, specify an intermediate flange that matches the motor used.

Compatibility Table: Motors Used, Intermediate Flanges, and Couplings

Motor type	Manufacturer	Series	Motor model	Motor rated output (W)	Flange size	Housing A/ Intermediate flange	Compatible coupling models							
							MIKI PULLEY CO., LTD.	Nabeya Bi-tech Kaisha (NBK)						
AC servo motor	YASKAWA Electric Corporation	Σ-V	SGMJV-A5	50	40×40	AQ	SFC-020DA2-6B-8B	XGT2-19C-6-8						
			SGMAV-A5											
			SGMJV-01	100										
			SGMAV-C2											
		Σ-7	SGM7J-A5	50	40×40	AQ	SFC-020DA2-6B-8B	XGT2-19C-6-8						
			SGM7A-A5											
			SGM7J-01	100										
			SGM7A-01											
		Σ-X	SGMXJ-A5	50	40×40	AQ	SFC-020DA2-6B-8B	XGT2-19C-6-8						
			SGMXA-A5											
			SGMXJ-01	100										
			SGMXA-01											
	Mitsubishi Electric Corporation	MELSERVO	J4	HG-KR053	50	40×40	AQ	SFC-020DA2-6B-8B	XGT2-19C-6-8					
				HG-MR053										
				HG-KR13										
			J5	HG-MR13	100									
				HK-KT053W										
				HK-KT13W										
	JN	HF-KN053	50	40×40	AQ	SFC-020DA2-6B-8B	XGT2-19C-6-8							
		HF-KN13												
	TAMAGAWA SEIKI CO., LTD.	TBL-iii	TS4602	TS4603	50	40×40	AQ	SFC-020DA2-6B-8B	XGT2-19C-6-8					
				TS4604										
				TS4604										
			TBL-iiV	TSM3102	50					40×40	AQ	SFC-020DA2-6B-8B	XGT2-19C-6-8	
				TSM3104										
				TSM3104										
	Panasonic Corporation	MINAS	A5	MSMD5A	50	38×38	AP	SFC-020DA2-6B-8B	XGT2-19C-6-8					
				MSME5A										
				MSMD01										
				MSME01										
A6			MSMF5A	50	38×38					AP	SFC-020DA2-6B-8B	XGT2-19C-6-8		
			MHMF5A		40×40					AQ				
			MSMF01	100	38					AP	SFC-020DA2-6B-8B	XGT2-19C-6-8		
			MHMF01		40×40					AQ				
			KEYENCE CORPORATION	SV	SV-M005					50	40×40	AQ	SFC-020DA2-6B-8B	XGT2-19C-6-8
					SV-M010									
SV2	SV2-M005	50												
	SV2-M010													
SANYO DENKI CO., LTD.	SANMOTION R	R2□A04005	50	40×40	AQ	SFC-020DA2-6B-8B	XGT2-19C-6-8							
		R2EA04008												
		R2□A04010												
OMRON Corporation	OMNUC G5	R88M-K05030	50	40×40	AQ	SFC-020DA2-6B-8B	XGT2-19C-6-8							
		R88M-K10030												
FANUC CORPORATION	βis Series	R88M-1M10030	100	40×40	AQ	SFC-020DA2-6B-8B	XGT2-19C-6-8							
		βis0.2/5000												
		βis0.3/5000	100											

Motor type	Manufacturer	Series	Motor model	Flange size	Housing A/ Intermediate flange	Compatible coupling models		
						MIKI PULLEY CO., LTD.	Nabeya Bi-tech Kaisha (NBK)	
Stepper motor	ORIENTAL MOTOR CO., LTD.	α step	AZ4*, AR4* (excluding AZM48)	42×42	AR	SFC-010DA2-6B-6B-L32	XGT2-15C-6-6	
			AZM48	42×42	AR	SFC-010DA2-6B-8B-L32	XGT2-19C-6-8	
		5-phase	CRK <sup>1</sup>	AZ6*, AR6*	60×60	AU	SFC-020DA2-6B-10B	XGT2-25C-6-10
				CRK54*	42×42	AR	SFC-010DA2-5B-6B-L32	XGT2-15C-5-6
				CRK56* (CRK569PM*)	60×60	AU	SFC-020DA2-6B-8B (SFC-020DA2-6B-10B)	XGT2-25C-6-8 (XGT2-25C-6-10)
				RKS54*	42×42	AR	SFC-010DA2-6B-6B-L32	XGT2-15C-6-6
			RK II	RKS56*	60×60	AU	SFC-020DA2-6B-10B	XGT2-25C-6-10
				PKP54*	42×42	AR	SFC-010DA2-5B-6B-L32	XGT2-15C-5-6
				PKP56*	56.4×56.4	AT	SFC-020DA2-6B-8B	XGT2-19C-6-8
				PKP56* (PKP569FM*)	60×60	AU	SFC-020DA2-6B-8B (SFC-020DA2-6B-10B)	XGT2-25C-6-8 (XGT2-25C-6-10)
		2-phase	PKP/CVD	PKP24*	42×42	AR	SFC-010DA2-5B-6B-L32	XGT2-15C-5-6
			PKP26*	56.4×56.4	AT	SFC-020DA2-6B-8B	XGT2-25C-6-8	
		KEYENCE CORPORATION	2-phase	QS-M42	42×42	AR	SFC-010DA2-5B-6B-L32	XGT2-15C-5-6
				QS-M60	60×60	AU	SFC-020DA2-6B-8B	XGT2-25C-6-8
	SANYO DENKI CO., LTD.	PB	PBDM423, PBA**423	42×42	AR	SFC-010DA2-6B-6B-L32	XGT2-15C-6-6	
			PBDM60*, PBA**60*	60×60	AU	SFC-020DA2-6B-10B-L34	XGT2-25C-6-10	
		5-phase	FAF54*/FDF54*/FA511M42/FB511M42	42×42	AR	SFC-010DA2-6B-6B-L32	XGT2-15C-6-6	
			FAM56*/FDM56*/FA512M60/FB512M60	60×60	AU	SFC-020DA2-6B-10B-L34	XGT2-25C-6-10	
			2-phase	DB14H52*	42×42	AR	SFC-010DA2-5B-6B-L32	XGT2-15C-5-6
		DU15H52*		AR		SFC-010DA2-5B-6B-L32	XGT2-15C-5-6	
D*16H71*		56×56		AT	SFC-020DA2-6B-6.35B-L34	XGT2-19C-6-6.35		
DB16H78*		60×60		AU	SFC-020DA2-6B-8B-L34	XGT2-25C-6-8		

<sup>1</sup> Items in parentheses have different motor shaft diameters and require a coupling to be specified.  
 Notes: 1. The table shows only a portion of the model numbers for motors. For details regarding model numbers, please see the catalog for each respective motor manufacturer.  
 2. If the maximum torque for motors exceeds the permissible input torque (A/B → p. 43, C/D → p. 49), please consider a safety measure to limit the torque.  
 3. When installing a motor other than the motor model numbers listed above, contact THK.

Housing A

KR30H
A0

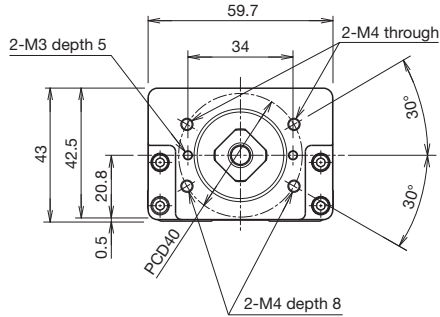

KR**	Actuator model
●◇	●: Housing A ◇: Intermediate flange

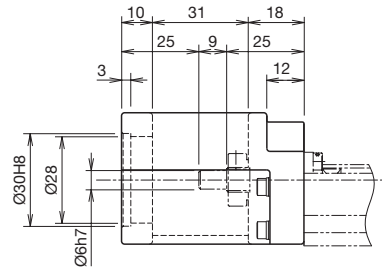

Intermediate Flange

KR30H
AP

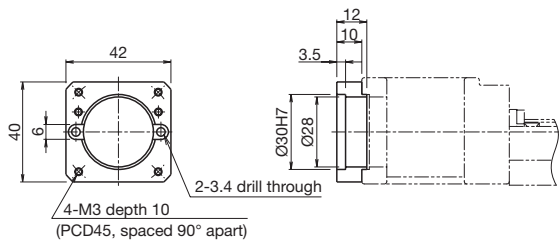

KR30H
AQ

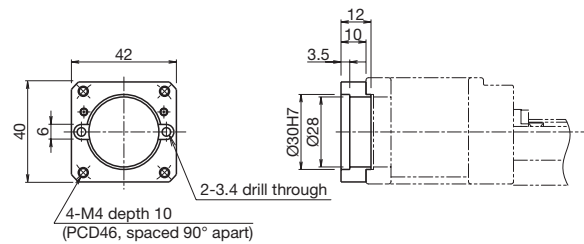

KR30H
AR

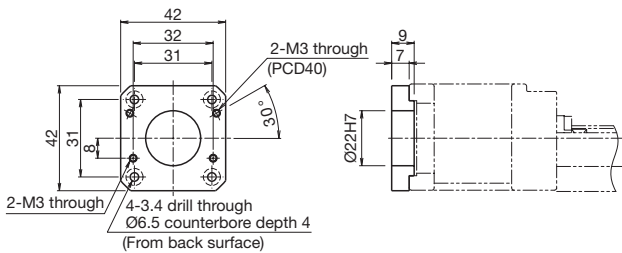

KR30H
AT

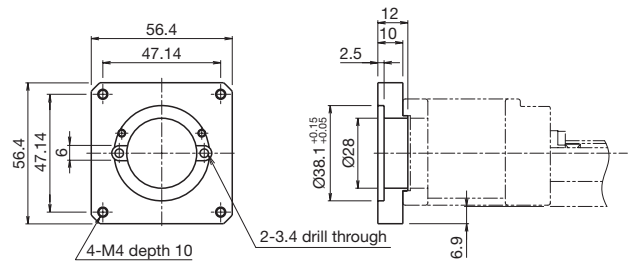

KR30H
AU

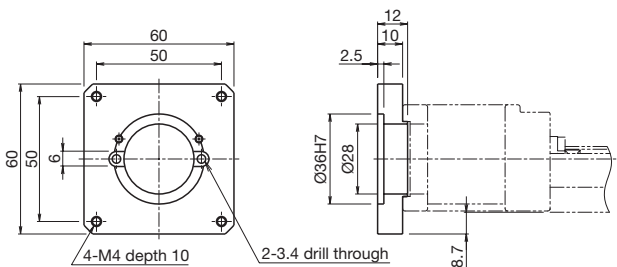

# Options

## Intermediate Flange (Motor Wrap)

Several types of intermediate flanges for mounting motors are available.

When selecting "R1," "R2," "R3," "R4," "R5," or "R6" for Model Number Coding ⑥ With/without motor, specify an intermediate flange that matches the motor used.

### Symbol Coding

Motor wrap symbol ①	Intermediate flange ②	Motor shaft diameter (mm) ③	Motor shaft securing method ④
W	Q	08	D
W	Refer to the Compatibility Table: Motors Used and Motor Wrap Symbols below.	Specify a motor shaft diameter. (Refer to the Compatibility Table: Motors Used and Motor Wrap Symbols below.)	K: Key D: D-cut M: Friction tightening tool

### Motor Shaft Securing Method

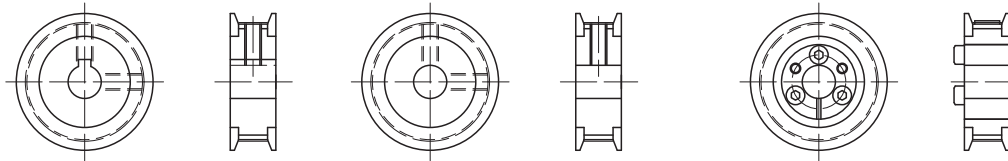

Key

D-cut

Friction tightening tool

Compatibility Table: Motors Used and Motor Wrap Symbols

Motor type	Manufacturer	Series	Motor model	Motor rated output (W)	Flange size	Housing A/Intermediate flange		
AC servo motor	YASKAWA Electric Corporation	Σ-V	SGMJV-A5	50	40×40	WQ-08K, WQ-08M		
			SGMAV-A5					
			SGMJV-01	100				
			SGMAV-01					
		SGMJV-C2	150					
		Σ-7	SGM7J-A5	50	40×40			
			SGM7A-A5					
			SGM7J-01	100				
			SGM7A-01					
		SGM7J-C2	150					
		Σ-X	SGMXJ-A5	50	40×40			
			SGMXA-A5					
	SGMXJ-01		100					
	SGMXA-01							
	SGMXJ-C2	150						
	SGMXA-C2							
	Mitsubishi Electric Corporation	MELSERVO	J4	HG-KR053	50	40×40	WQ-08D, WQ-08M	
				HG-MR053				
			HG-KR13	100				
			HG-MR13					
		J5	HK-KT053W	50	40×40			
			HK-KT13W	100				
		JN	HF-KN053	50	40×40			
			HF-KN13	100				
	TAMAGAWA SEIKI CO., LTD.	TBL-III	TS4602	50	40×40	WQ-08D, WQ-08M		
			TS4603	100				
			TS4604	150				
		TBL-IV	TSM3102	50	40×40			
			TSM3104	100				
	Panasonic Corporation	MINAS	A5	MSMD5A	50	38×38	WP-08D, WP-08K, WP-08M	
				MSME5A				
			MSMD01	100				
			MSME01					
		A6	MSMF5A	50	38×38			WP-08K, WP-08M
			MHMF5A	50	40×40			WQ-08K, WQ-08M
MSMF01			100	38×38	WP-08K, WP-08M			
MHMF01				40×40	WQ-08K, WQ-08M			
KEYENCE CORPORATION	SV	SV-M005	50	40×40	WQ-08K, WQ-08M			
		SV-M010	100					
	SV2	SV2-M005	50					
		SV2-M010	100					
SANYO DENKI CO., LTD.	SANMOTION R	R2□A04005	50	40×40	WQ-08M			
		R2EA04008	80					
		R2□A04010	100					
		R2EA04010	100					
OMRON Corporation	OMNUC G5	R88M-K05030	50	40×40	WQ-08K, WQ-08M			
		R88M-K10030	100					
	1S	R88M-1M10030	100			40×40	WQ-08K, WQ-08M	

Notes: 1. The table shows only a portion of the model numbers for motors. For details regarding model numbers, please see the catalog for each respective motor manufacturer.  
 2. If the maximum torque for motors exceeds the permissible input torque (A/B → p. 43, C/D → p. 49), please consider a safety measure to limit the torque.  
 3. When installing a motor other than the motor model numbers listed above, contact THK.

### Motor Wrap Housing A

KR30H
40

KR**	Actuator model
●◇	●: Housing A ◇: Intermediate flange

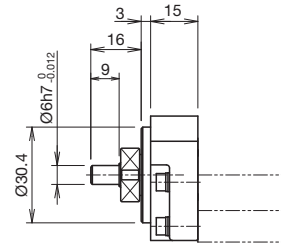
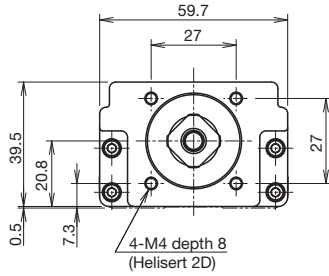

Note: The shaft end must be considered separately with motor wrap types. Contact THK for details.

### Motor Wrap Specification (Intermediate Flange)

KR30H
WQ

Thickness: 5 mm

KR30H
WP

Thickness: 5 mm

KR**	Actuator model
W□	□: Intermediate flange

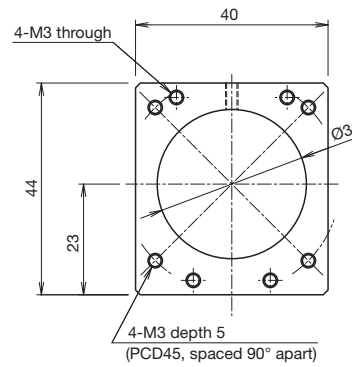
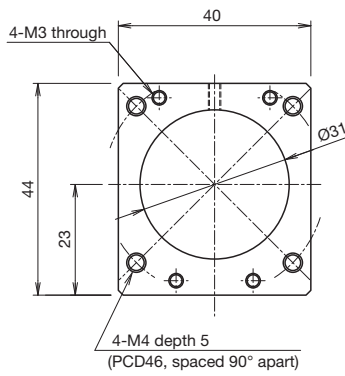

# KR33 A/B

Direct motor coupling

Motor wrap

Width 60 mm

Height 33 mm

Max. stroke 600 mm

## Model Number Coding

Model	Ball screw lead	Block type	QZ specification	Stroke	Accuracy grade	With/without motor	Cover	Sensors	Housing A/ Intermediate flange
①	②	③	④	⑤	⑥	⑦	⑧	⑨	⑩
KR33	06	A	QZA	0085	P	0	1	2	AQ
<b>KR33</b>	<b>05: 5 mm</b> <b>06: 6 mm</b> <b>10: 10 mm</b>	<b>A: x1</b> <b>B: x2</b>	<b>No symbol: Without QZ</b> <b>QZ</b> <b>QZA</b> <b>QZB</b> <b>QZAD</b>	<b>0050: 50 mm</b> to <b>0600: 600 mm</b>	<b>No symbol: Normal grade</b> <b>H: High accuracy grade</b> <b>P: Precision grade</b>	<b>With direct coupling</b> <b>0: Direct coupling (without motor)</b> <b>1: Direct coupling (THK will purchase and mount the motor you specify.)</b> <b>With motor wrap</b> <b>R1: Non-standard side wrap (without motor)</b> <b>R2: Standard side wrap (without motor)</b> <b>R3: Bottom side wrap (without motor)</b> <b>R4: Non-standard side wrap (THK will purchase and mount the motor you specify.)</b> <b>R5: Standard side wrap (THK will purchase and mount the motor you specify.)</b> <b>R6: Bottom side wrap (THK will purchase and mount the motor you specify.)</b>	<b>0: Without cover</b> <b>1: With cover</b> <b>2: With bellows</b>	<b>0</b> <b>1</b> <b>2</b> <b>6</b> <b>7</b> <b>B</b> <b>E</b> <b>H</b> <b>L</b> <b>J</b> <b>M</b> Sensor details → p. 73	<b>With direct coupling</b> <b>A0</b> <b>AP</b> <b>AQ</b> <b>AR</b> <b>AT</b> <b>AU</b> <b>40</b> <b>With motor wrap</b> <b>WP-08D</b> <b>WP-08K</b> <b>WP-08M</b> <b>WQ-08D</b> <b>WQ-08K</b> <b>WQ-08M</b>
<p>When selecting "05" for "② Ball screw lead," QZ specification cannot be selected.</p> <p>Check the stroke for type with QZ when selecting anything other than "No symbol." → p. 79 to p. 84</p> <p>When selecting "0": A coupling is not provided. Indicate when placing an order if a coupling is required.</p> <p>When selecting "1," "R4," "R5," or "R6": The specified motor will be installed. Indicate the motor cable direction separately. Select ⑩ Intermediate flange to match the specified motor.</p> <p>With direct coupling → p. 75 With motor wrap → p. 77</p>									

### ③ Block Type

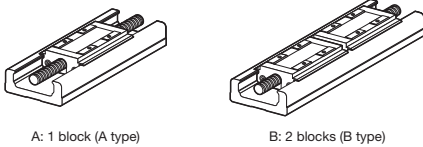

### ⑦ Motor Mounting Method

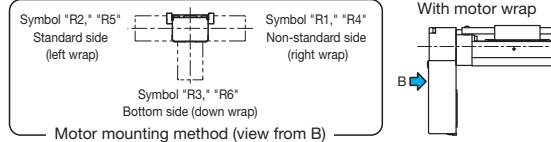

## Selection Information

### Basic Specifications

LM Guide	Basic dynamic load rating C (N)		14,800
	Basic static load rating C <sub>0</sub> (N)		22,900
	Radial clearance (mm)	Normal grade/High accuracy grade (H)	-0.004 to +0.002
		Precision grade (P)	-0.012 to -0.004
	Geometric moment of inertia	I <sub>x</sub> <sup>1</sup> (mm <sup>4</sup> )	6.2×10 <sup>4</sup>
I <sub>y</sub> <sup>2</sup> (mm <sup>4</sup> )		3.8×10 <sup>5</sup>	
Mass (kg/m)		6.6	
Ball screw	Ball screw lead (mm)		5   6   10
	Basic dynamic load rating Ca (N)	Normal grade/High accuracy grade (H)	2,950   2,840   1,760
		Precision grade (P)	1,860   2,250   1,370
	Basic static load rating C <sub>0a</sub> (N)	Normal grade/High accuracy grade (H)	5,390   4,900   2,840
		Precision grade (P)	2,690   2,740   1,570
	Screw shaft diameter (mm)		Ø10
	Thread minor diameter (mm)		Ø7.8
	Ball center-to-center diameter (mm)		Ø10.5
Permissible rotational speed <sup>3</sup> (min <sup>-1</sup> )	Normal grade/High accuracy grade (H)	4,700	
	Precision grade (P)	6,000	
Bearing unit (fixed side)	Axial direction	Basic dynamic load rating Ca (N)	1,790
		Static permissible load P <sub>0a</sub> (N)	2,590
Permissible input torque (N·m)	Direct coupling		1.2
	Motor wrap		0.98
Static permissible moment <sup>4,5</sup> (N·m)		M <sub>A</sub> : 166 (908), M <sub>B</sub> : 166 (908), M <sub>C</sub> : 428 (857)	
Service life <sup>6</sup> (km)		5,000   10,000	
Standard grease/Grease nipple used		THK AFB-LF Grease/PB107	

- <sup>1</sup> I<sub>x</sub> is the geometric moment of inertia about the X axis.  
<sup>2</sup> I<sub>y</sub> is the geometric moment of inertia about the Y axis.  
<sup>3</sup> The permissible rotational speed may decrease as the stroke becomes longer.  
<sup>4</sup> The value in parentheses is with 2 blocks (B type) attached.  
<sup>5</sup> See p. 172 for the values if "1" or "2" is selected for item ⑧ in the Model Number Coding.  
<sup>6</sup> Calculated under the following conditions.  
 Stroke: 400 mm (A type), 325 mm (B type) / Speed: 250 mm/s (for 5 mm lead), 300 mm/s (for 6 mm lead), 500 mm/s (for 10 mm lead) / Load mass: Maximum load capacity (p. 9) / Acceleration/deceleration: As when set to maximum load capacity (p. 9) / Center of gravity: Center of the table's upper surface.
- Notes: 1. LM Guide load rating is the load rating per block.  
 2. Precision grade (P-grade) ball screws have integrated spacer balls with a 1:1 ratio.

### Geometric Moment of Inertia

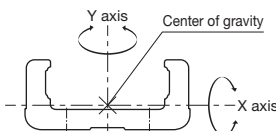

### Static Permissible Moment

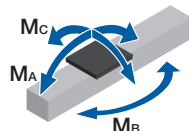

### Accuracy

Accuracy grade	Item	Stroke <sup>7</sup>						
		50	100	200	300	400	500	600
Normal grade (no symbol)	Positioning repeatability (mm)	±0.01						
	Positioning accuracy (mm)	Not specified						
	Running parallelism (vertical direction) (mm)	Not specified						
	Backlash (mm)	0.02						
	Starting torque (N·cm)	7						
High accuracy grade (H)	Positioning repeatability (mm)	±0.005						
	Positioning accuracy (mm)	0.06		0.1		0.14		
	Running parallelism (vertical direction) (mm)	0.02		0.035				
	Backlash (mm)	0.01						
	Starting torque (N·cm)	7						
Precision grade (P)	Positioning repeatability (mm)	±0.003						
	Positioning accuracy (mm)	0.02		0.025		0.03		
	Running parallelism (vertical direction) (mm)	0.01		0.015				
	Backlash (mm)	0.003						
	Starting torque (N·cm)	15						

- <sup>7</sup> Stroke with 1 block (A type, without QZ).  
 Notes: 3. Precision evaluation in accordance with THK standards.  
 4. Measured using a motor for inspection. With motor wrap specifications, measurements are not made in the completed motor wrap state.  
 5. The starting torque represents the value when containing THK AFB-LF Grease.  
 6. The starting torque may exceed standards if using vacuum grease, clean room grease, or other high-viscosity greases, so care should be taken when selecting a motor.  
 7. Contact THK for accuracy higher than the standard stroke.

### Motor Selection Information

Stroke <sup>1</sup> (mm)	Outer rail length (mm)	LM Guide				Ball screw		Motor mounting part	
		Moving part mass (kg)			Sliding resistance value <sup>2</sup> (N)	Lead (mm)	Shaft length (mm)	Direct coupling	Motor wrap
		Block mass	Sub-table mass	Total mass				Shaft end diameter (mm)	Timing pulley (sum of two) Inertial moment x 10 <sup>-4</sup> (kg·m <sup>2</sup> )
50 to 600	150 to 700	A type: 0.4 B type: 0.8	A type: 0.2 B type: 0.4	A type: 0.6 B type: 1.2	3.4	5, 6, 10	194 to 744	Ø6h7	0.041

<sup>1</sup> Stroke with 1 block (A type, without QZ).

<sup>2</sup> Value with 1 block (A type, without QZ). This value is the sum of the rolling resistance value and seal resistance value.

Note: Refer to p. 75 for applicable couplings.

### Permissible Overhang Length<sup>3</sup>

Horizontal

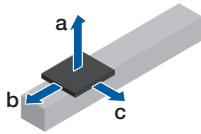

Wall-Mounted

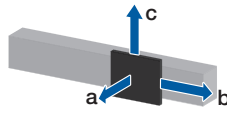

Vertical

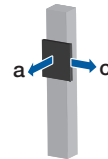

Estimated motor capacity 100 W	Ball screw lead (mm)	Load mass (kg)	a	b	c		
			(mm)	(mm)	(mm)		
Direct coupling	A type	5	10.5	600	120	180	
			21.5	280	50	90	
			43.5	120	20	40	
		6	10.5	600	120	180	
			21.5	280	50	90	
			43.5	120	20	40	
	10	9	600	110	210		
		18.5	320	50	100		
		37.5	150	20	50		
		B type	5	15	600	510	260
				30.5	600	240	120
				61.5	510	110	60
6	15		600	510	260		
	30.5		600	240	120		
	61.5		510	110	60		
10	9	600	600	430			
	18.5	600	320	210			
	37.5	600	150	100			

Estimated motor capacity 100 W	Ball screw lead (mm)	Load mass (kg)	a	b	c		
			(mm)	(mm)	(mm)		
Direct coupling	A type	5	8	220	150	530	
			16.5	90	60	250	
			33	30	20	120	
		6	8	220	150	530	
			16	90	70	260	
			32.5	30	20	130	
	10	6	300	160	600		
		12	130	70	350		
		24	50	30	170		
		B type	5	12	300	290	600
				24.5	130	140	480
				49	50	70	240
6	12		300	290	600		
	24.5		130	140	480		
	49		50	70	240		
10	9	410	390	600			
	18.5	180	190	600			
	37.5	70	90	310			

Estimated motor capacity 100 W	Ball screw lead (mm)	Load mass (kg)	a	c		
			(mm)	(mm)		
Direct coupling	A type	5	3.5	350	270	
			7	160	130	
			14.5	70	60	
		6	3.5	340	280	
			7.5	150	130	
			15	60	60	
	10	3	330	320		
		6	150	150		
		12	60	60		
		B type	5	3.5	600	600
				7	600	390
				14	520	190
6	3.5		600	600		
	7.5		600	360		
	15		480	180		
10	3	600	600			
	6	600	450			
	12.5	480	210			

<sup>3</sup> This is the value with the service life of the LM Guide limited to 5,000 km (for leads of 5 mm and 6 mm) or 10,000 km (for leads of 10 mm). The calculation conditions are as follows.  
Stroke: 325 mm (A type, B type) / Acceleration/deceleration: 0.3 G / Speed: 250 mm/s (for 5 mm lead), 300 mm/s (for 6 mm lead), 500 mm/s (for 10 mm lead) / Overhang direction: Loaded only in a single direction. Dimensions a, b, and c are from the center of the table's upper surface.

With Cover  
Direct Motor Coupling

Dimensions

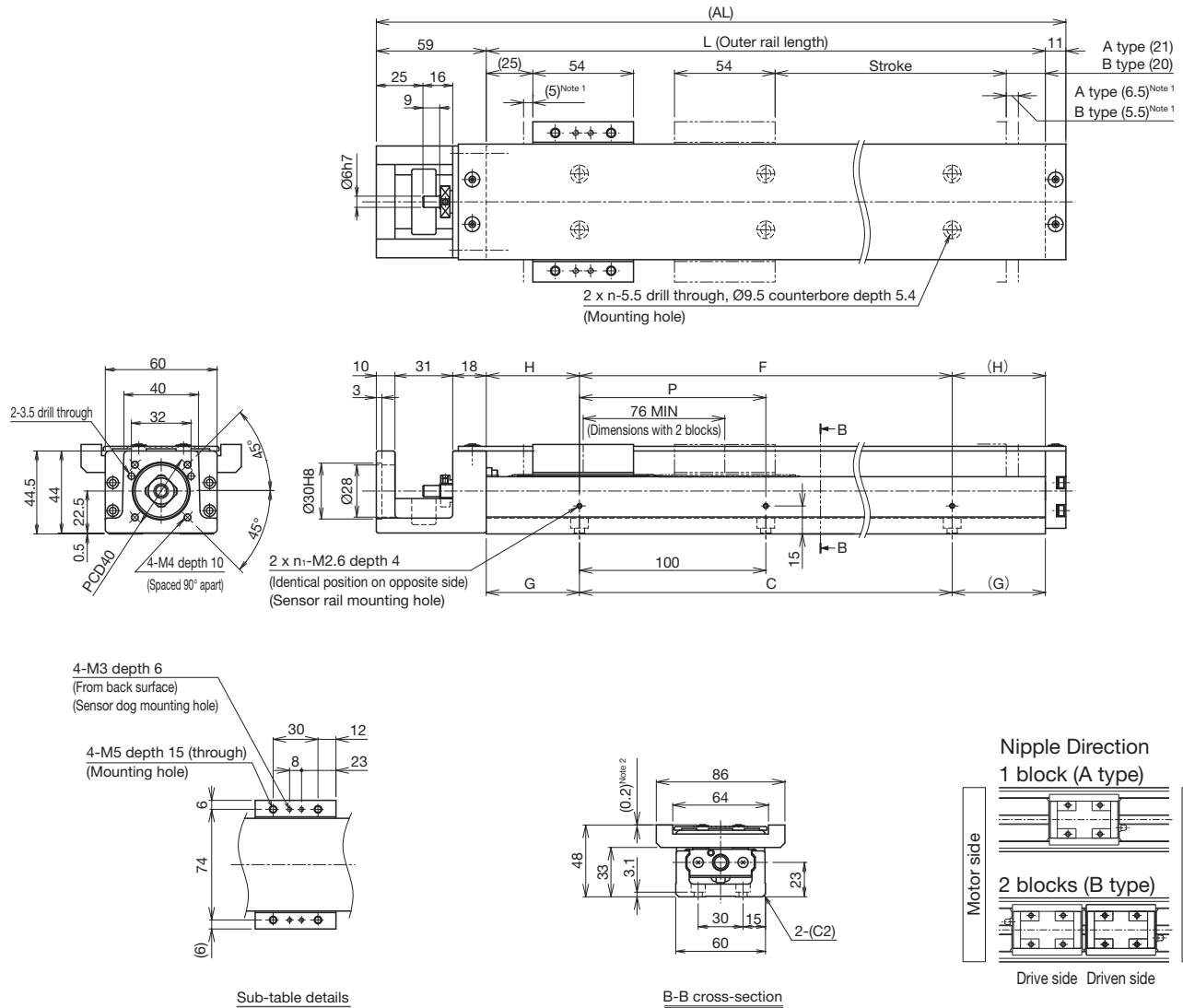

<sup>1</sup> Dimensions from the mechanical stopper to the stroke start position.  
<sup>2</sup> When designing the components that will be mounted to the sub-table, please note that the upper surface of the cover mounting bolts will be higher than the upper surface of the sub-table.

Stroke (mm) (Stroke between mechanical stoppers)	A type	50 (61.5)	100 (111.5)	200 (211.5)	300 (311.5)	400 (411.5)	500 (511.5)	600 (611.5)
	B type <sup>3</sup>	-	-	125 (135.5)	225 (235.5)	325 (335.5)	425 (435.5)	525 (535.5)
Maximum speed <sup>4</sup> (mm/s)	Ball screw lead: 5 mm	Normal grade/High accuracy grade	390		330	230		
		Precision grade	500		330	230		
	Ball screw lead: 6 mm	Normal grade/High accuracy grade	470		390	280		
		Precision grade	600		590	390	280	
Ball screw lead: 10 mm	Normal grade/High accuracy grade	790		650	470			
	Precision grade	1,000		980	650	470		
Dimensions (mm)	AL	220	270	370	470	570	670	770
	L	150	200	300	400	500	600	700
	C	100	100	200	300	400	500	600
	G	25	50	50	50	50	50	50
	P	100	100	200	200	200	200	200
	F	100	100	200	200	400	400	600
	H	25	50	50	100	50	100	50
No. of mounting holes	n	2	2	3	4	5	6	7
	n <sub>1</sub>	2	2	2	2	3	3	4
Mass <sup>5</sup> (kg)		2.2	2.6	3.3	4.1	4.9	5.6	6.4

<sup>3</sup> The value with 2 blocks (B type, without QZ) attached.  
<sup>4</sup> The maximum speed is restricted by the actuator's permissible speed.  
<sup>5</sup> The mass with 2 blocks (B type) has 0.6 kg added.

Without Cover  
Direct Motor Coupling

**Dimensions**

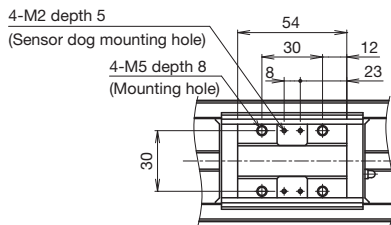
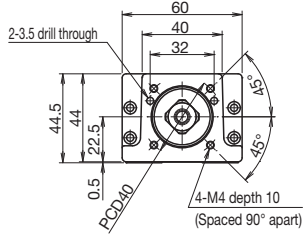
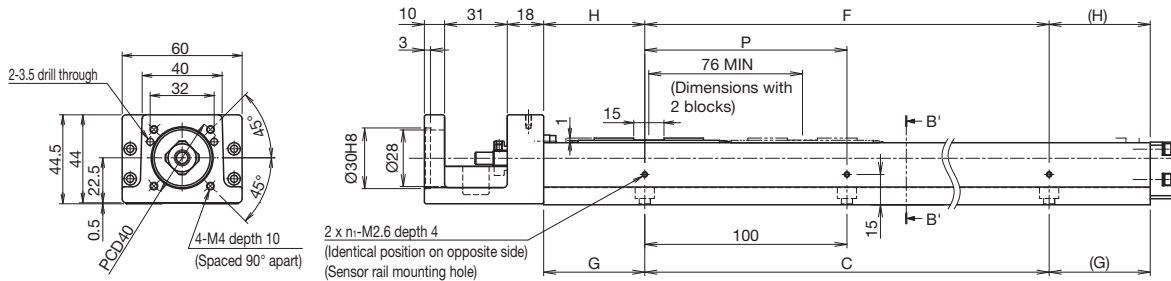
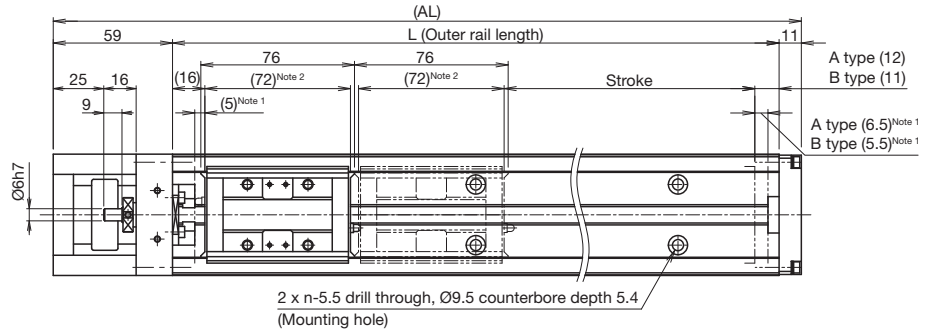

Block details

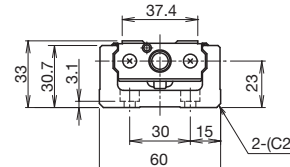

B'-B' cross-section

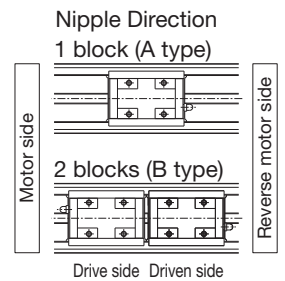

<sup>1</sup> Dimensions from the mechanical stopper to the stroke start position.  
<sup>2</sup> Shows the block length when calculating the enabled stroke range. 148 mm (2 blocks total) for KR33 with 2 blocks (B type, without QZ).

Stroke (mm) (Stroke between mechanical stoppers)	A type	50 (61.5)	100 (111.5)	200 (211.5)	300 (311.5)	400 (411.5)	500 (511.5)	600 (611.5)	
	B type <sup>3</sup>	-	-	125 (135.5)	225 (235.5)	325 (335.5)	425 (435.5)	525 (535.5)	
Maximum speed <sup>4</sup> (mm/s)	Ball screw lead: 5 mm	Normal grade/High accuracy grade		390			330	230	
		Precision grade		500			330	230	
	Ball screw lead: 6 mm	Normal grade/High accuracy grade			470			390	280
		Precision grade		600			590	390	280
Ball screw lead: 10 mm	Normal grade/High accuracy grade			790			650	470	
	Precision grade		1,000			980	650	470	
Dimensions (mm)	AL	220	270	370	470	570	670	770	
	L	150	200	300	400	500	600	700	
	C	100	100	200	300	400	500	600	
	G	25	50	50	50	50	50	50	
	P	100	100	200	200	200	200	200	
	F	100	100	200	200	400	400	600	
No. of mounting holes	n	2	2	3	4	5	6	7	
	n <sub>1</sub>	2	2	2	2	3	3	4	
Mass <sup>5</sup> (kg)		1.9	2.2	3	3.7	4.4	5.2	5.9	

<sup>3</sup> The value with 2 blocks (B type, without QZ) attached.  
<sup>4</sup> The maximum speed is restricted by the actuator's permissible speed.  
<sup>5</sup> The mass with 2 blocks (B type) has 0.4 kg added.

With Cover  
Motor Wrap

Dimensions

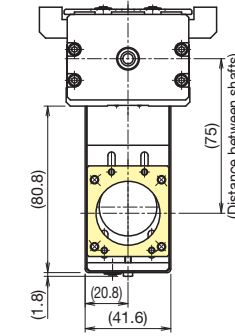
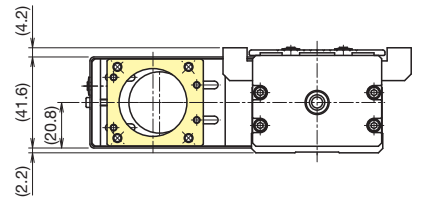
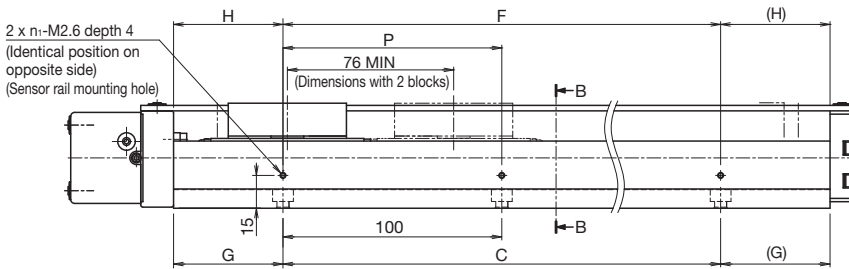
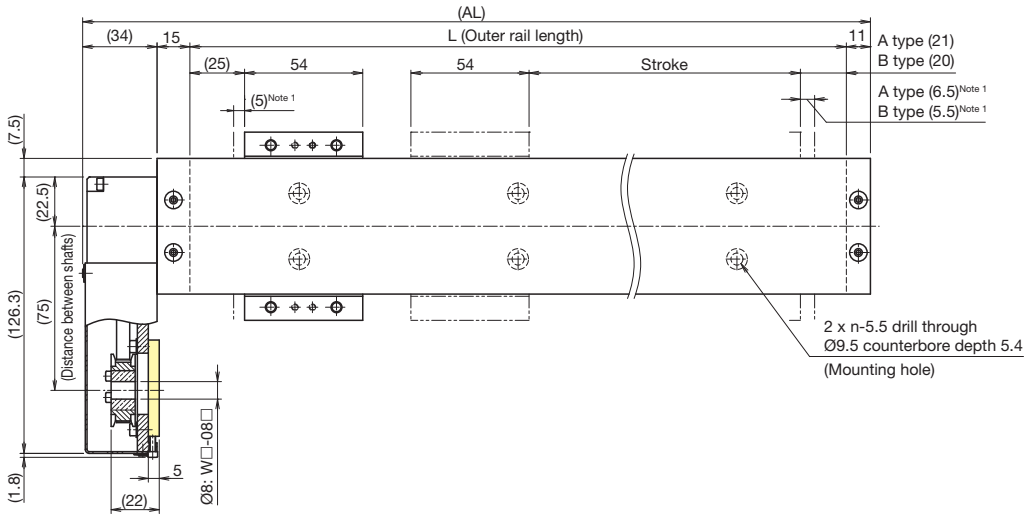

With bottom side wrap selected

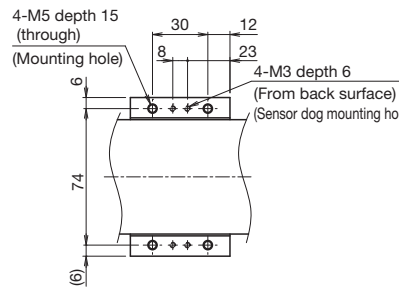

Sub-table details

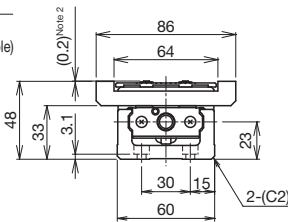

B-B cross-section

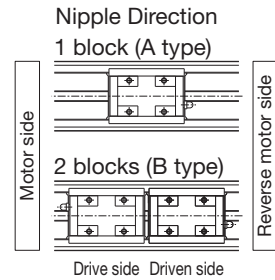

<sup>1</sup> Dimensions from the mechanical stopper to the stroke start position.  
<sup>2</sup> When designing the components that will be mounted to the sub-table, please note that the upper surface of the cover mounting bolts will be higher than the upper surface of the sub-table.

Stroke (mm) (Stroke between mechanical stoppers)	A type	50 (61.5)	100 (111.5)	200 (211.5)	300 (311.5)	400 (411.5)	500 (511.5)	600 (611.5)
	B type <sup>3</sup>	-	-	125 (135.5)	225 (235.5)	325 (335.5)	425 (435.5)	525 (535.5)
Maximum speed <sup>4</sup> (mm/s)	Ball screw lead: 5 mm	Normal grade/High accuracy grade			390		330	230
		Precision grade			500		330	230
	Ball screw lead: 6 mm	Normal grade/High accuracy grade			470		390	280
		Precision grade			600		390	280
Ball screw lead: 10 mm	Normal grade/High accuracy grade	790			590		650	470
	Precision grade	1,000			980		650	470
Dimensions (mm)	AL	210	260	360	460	560	660	760
	L	150	200	300	400	500	600	700
	C	100	100	200	300	400	500	600
	G	25	50	50	50	50	50	50
	P	100	100	200	200	200	200	200
	F	100	100	200	200	400	400	600
	H	25	50	50	100	50	100	50
No. of mounting holes	n	2	2	3	4	5	6	7
	n <sub>1</sub>	2	2	2	2	3	3	4
Mass <sup>5</sup> (kg)		2.5	2.9	3.6	4.4	5.2	5.9	6.7

<sup>3</sup> The value with 2 blocks (B type, without Q2) attached.  
<sup>4</sup> The maximum speed is restricted by the actuator's permissible speed.  
<sup>5</sup> The mass with 2 blocks (B type) has 0.6 kg added.

Without Cover  
Motor Wrap

Dimensions

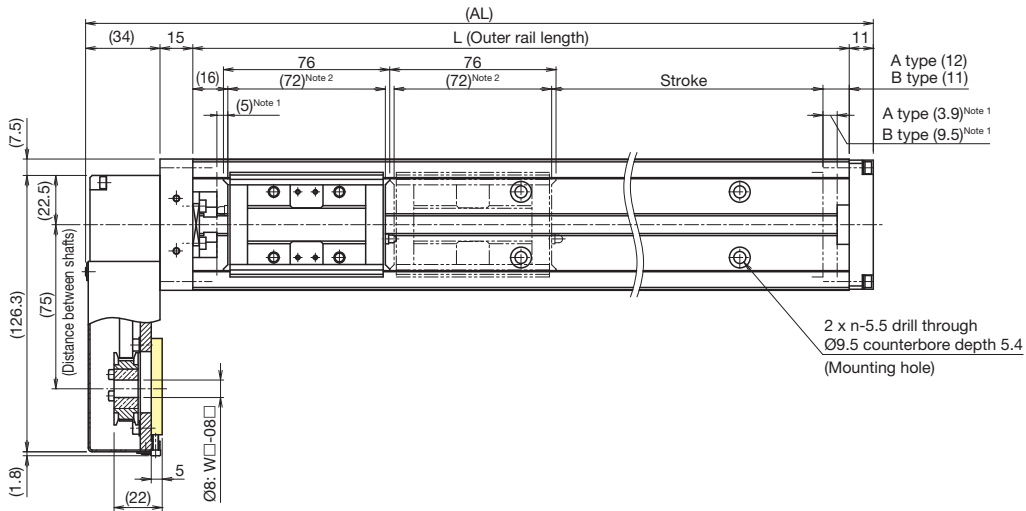

A type (12)  
B type (11)  
A type (3.9)<sup>Note 1</sup>  
B type (9.5)<sup>Note 1</sup>

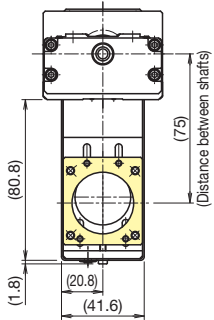
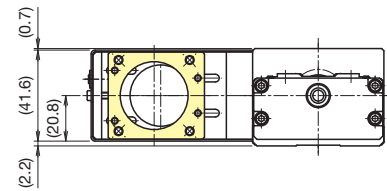
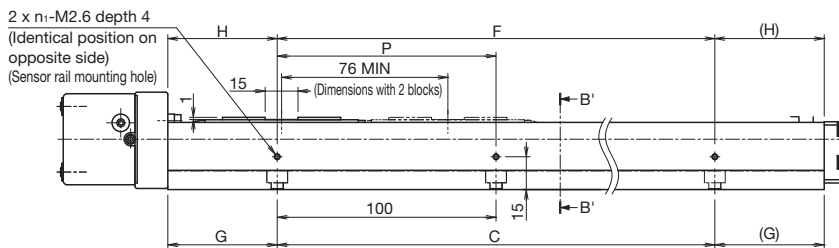

With bottom side wrap selected

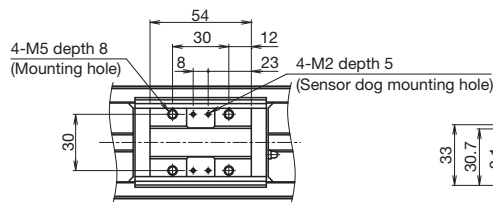

Block details

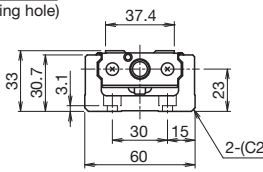

B'-B' cross-section

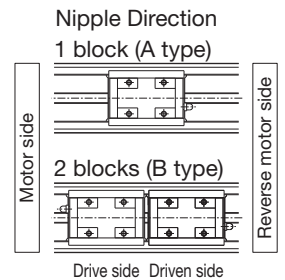

<sup>1</sup> Dimensions from the mechanical stopper to the stroke start position.  
<sup>2</sup> Shows the block length when calculating the enabled stroke range.  
148 mm (2 blocks total) for KR33 with 2 blocks (B type, without QZ).

Stroke (mm) (Stroke between mechanical stoppers)	A type	50 (61.5)	100 (111.5)	200 (211.5)	300 (311.5)	400 (411.5)	500 (511.5)	600 (611.5)
	B type <sup>3</sup>	-	-	125 (135.5)	225 (235.5)	325 (335.5)	425 (435.5)	525 (535.5)
Maximum speed <sup>4</sup> (mm/s)	Ball screw lead: 5 mm	Normal grade/High accuracy grade		390		330		230
		Precision grade		500		330		230
	Ball screw lead: 6 mm	Normal grade/High accuracy grade		470		390		280
		Precision grade		600		590		390
Ball screw lead: 10 mm	Normal grade/High accuracy grade		790		650		470	
	Precision grade		1,000		980		650	470
Dimensions (mm)	AL	210	260	360	460	560	660	760
	L	150	200	300	400	500	600	700
	C	100	100	200	300	400	500	600
	G	25	50	50	50	50	50	50
	P	100	100	200	200	200	200	200
	F	100	100	200	200	400	400	600
	H	25	50	50	100	50	100	50
No. of mounting holes	n	2	2	3	4	5	6	7
	n <sub>1</sub>	2	2	2	2	3	3	4
Mass <sup>5</sup> (kg)		2.2	2.6	3.3	4	4.7	5.5	6.2

<sup>3</sup> The value with 2 blocks (B type, without QZ) attached.

<sup>4</sup> The maximum speed is restricted by the actuator's permissible speed.

<sup>5</sup> The mass with 2 blocks (B type) has 0.4 kg added.

# KR33 C/D

Direct motor coupling	Motor wrap	Width 60 mm	Height 33 mm	Max. stroke 625 mm
-----------------------	------------	-------------	--------------	--------------------

## Model Number Coding

Model	Ball screw lead	Block type	QZ specification	Stroke	Accuracy grade	With/without motor	Cover	Sensors	Housing A/ Intermediate flange
①	②	③	④	⑤	⑥	⑦	⑧	⑨	⑩
KR33	06	C	QZA	0060	P	0	1	2	AQ
<b>KR33</b>	<b>05: 5 mm</b> <b>06: 6 mm</b> <b>10: 10 mm</b>	<b>C: x1</b> <b>D: x2</b>	<b>No symbol: Without QZ</b> <b>QZ</b> <b>QZA</b> <b>QZB</b> <b>QZAD</b>	<b>0025: 25 mm</b> to <b>0625: 625 mm</b>	<b>No symbol: Normal grade</b> <b>H: High accuracy grade</b> <b>P: Precision grade</b>	<b>With direct coupling</b> <b>0: Direct coupling (without motor)</b> <b>1: Direct coupling (THK will purchase and mount the motor you specify.)</b> <b>With motor wrap</b> <b>R1: Non-standard side wrap (without motor)</b> <b>R2: Standard side wrap (without motor)</b> <b>R3: Bottom side wrap (without motor)</b> <b>R4: Non-standard side wrap (THK will purchase and mount the motor you specify.)</b> <b>R5: Standard side wrap (THK will purchase and mount the motor you specify.)</b> <b>R6: Bottom side wrap (THK will purchase and mount the motor you specify.)</b>	<b>0: Without cover</b> <b>1: With cover</b> <b>2: With bellows</b>	<b>0</b> <b>1</b> <b>2</b> <b>6</b> <b>7</b> <b>B</b> <b>E</b> <b>H</b> <b>L</b> <b>J</b> <b>M</b> <b>Sensor details</b> → p. 73	<b>With direct coupling</b> <b>A0</b> <b>AP</b> <b>AQ</b> <b>AR</b> <b>AT</b> <b>AU</b> <b>40</b> <b>With motor wrap</b> <b>WP-08D</b> <b>WP-08K</b> <b>WP-08M</b> <b>WQ-08D</b> <b>WQ-08K</b> <b>WQ-08M</b>
<p>When selecting "05" for "② Ball screw lead," QZ specification cannot be selected.</p> <p>Check the stroke for type with QZ when selecting anything other than "No symbol." → p. 79 to p. 84</p> <p>When selecting "0": A coupling is not provided. Indicate when placing an order if a coupling is required.</p> <p>When selecting "1," "R4," "R5," or "R6": The specified motor will be installed. Indicate the motor cable direction separately. Select ⑩ Intermediate flange to match the specified motor.</p> <p>With direct coupling → p. 75 With motor wrap → p. 77</p>									

### ③ Block Type

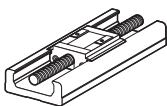

C: 1 short block (C type)

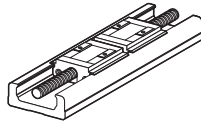

D: 2 short blocks (D type)

### ⑦ Motor Mounting Method

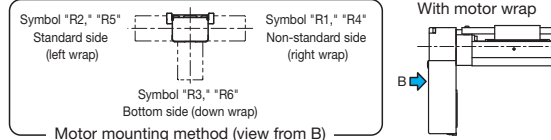

## Selection Information

### Basic Specifications

LM Guide	Basic dynamic load rating C (N)		9,500		
	Basic static load rating C <sub>0</sub> (N)		12,100		
	Radial clearance (mm)	Normal grade/High accuracy grade (H)	-0.004 to +0.002		
		Precision grade (P)	-0.012 to -0.004		
	Geometric moment of inertia	I <sub>x</sub> <sup>1</sup> (mm <sup>4</sup> )	6.2×10 <sup>4</sup>		
I <sub>y</sub> <sup>2</sup> (mm <sup>4</sup> )		3.8×10 <sup>5</sup>			
Mass (kg/m)		6.6			
Ball screw	Ball screw lead (mm)		5	6	10
	Basic dynamic load rating Ca (N)	Normal grade/High accuracy grade (H)	2,950	2,840	1,760
		Precision grade (P)	1,860	2,250	1,370
	Basic static load rating C <sub>0a</sub> (N)	Normal grade/High accuracy grade (H)	5,390	4,900	2,840
		Precision grade (P)	2,690	2,740	1,570
	Screw shaft diameter (mm)		Ø10		
	Thread minor diameter (mm)		Ø7.8		
	Ball center-to-center diameter (mm)		Ø10.5		
Permissible rotational speed <sup>3</sup> (min <sup>-1</sup> )	Normal grade/High accuracy grade (H)	4,700			
	Precision grade (P)	6,000			
Bearing unit (fixed side)	Axial direction	Basic dynamic load rating Ca (N)	1,790		
		Static permissible load P <sub>0a</sub> (N)	2,590		
Permissible input torque (N·m)	Direct coupling	1.2			
	Motor wrap	0.98			
Static permissible moment <sup>4,5</sup> (N·m)		M <sub>A</sub> : 44 (319), M <sub>B</sub> : 44 (319), M <sub>C</sub> : 214 (427)			
Service life <sup>6</sup> (km)		5,000	10,000		
Standard grease/Grease nipple used		THK AFB-LF Grease/PB107			

<sup>1</sup> I<sub>x</sub> is the geometric moment of inertia about the X axis.

<sup>2</sup> I<sub>y</sub> is the geometric moment of inertia about the Y axis.

<sup>3</sup> The permissible rotational speed may decrease as the stroke becomes longer.

<sup>4</sup> The value in parentheses is with 2 short blocks (D type) attached.

<sup>5</sup> See p. 172 for the values if "1" or "2" is selected for item ⑧ in the Model Number Coding.

<sup>6</sup> Calculated under the following conditions.

Stroke: 425 mm (C type), 375 mm (D type) / Speed: 250 mm/s (for 5 mm lead), 300 mm/s (for 6 mm lead), 500 mm/s (for 10 mm lead) / Load mass: Maximum load capacity (p. 9) / Acceleration/deceleration: As when set to maximum load capacity (p. 9) / Center of gravity: Center of the table's upper surface.

Notes: 1. LM Guide load rating is the load rating per short block.

2. Precision grade (P-grade) ball screws have integrated spacer balls with a 1:1 ratio.

### Accuracy

Accuracy grade	Item	Stroke <sup>7</sup>					
		75	125	225	325	425	525
Normal grade (no symbol)	Positioning repeatability (mm)	±0.01					
	Positioning accuracy (mm)	Not specified					
	Running parallelism (vertical direction) (mm)	Not specified					
	Backlash (mm)	0.02					
	Starting torque (N·cm)	7					

Accuracy grade	Item	Stroke <sup>7</sup>					
		75	125	225	325	425	525
High accuracy grade (H)	Positioning repeatability (mm)	±0.005					
	Positioning accuracy (mm)	0.06		0.1		0.14	
	Running parallelism (vertical direction) (mm)	0.02		0.035			
	Backlash (mm)	0.01					
	Starting torque (N·cm)	7					

Accuracy grade	Item	Stroke <sup>7</sup>					
		75	125	225	325	425	525
Precision grade (P)	Positioning repeatability (mm)	±0.003					
	Positioning accuracy (mm)	0.02		0.025		0.03	
	Running parallelism (vertical direction) (mm)	0.01		0.015			
	Backlash (mm)	0.003					
	Starting torque (N·cm)	15					

<sup>7</sup> Stroke with 1 short block (C type, without QZ).

Notes: 3. Precision evaluation in accordance with THK standards.

4. Measured using a motor for inspection. With motor wrap specifications, measurements are not made in the completed motor wrap state.

5. The starting torque represents the value when containing THK AFB-LF Grease.

6. The starting torque may exceed standards if using vacuum grease, clean room grease, or other high-viscosity greases, so care should be taken when selecting a motor.

7. Contact THK for accuracy higher than the standard stroke.

### Geometric Moment of Inertia

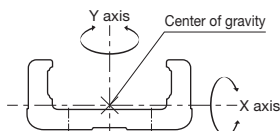

### Static Permissible Moment

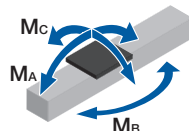

### Motor Selection Information

Stroke <sup>1</sup> (mm)	Outer rail length (mm)	LM Guide				Ball screw		Motor mounting part	
		Moving part mass (kg)			Sliding resistance value <sup>2</sup> (N)	Lead (mm)	Shaft length (mm)	Direct coupling	Motor wrap
		Block mass	Sub-table mass	Total mass				Shaft end diameter (mm)	Timing pulley (sum of two) Inertial moment x 10 <sup>-4</sup> (kg·m <sup>2</sup> )
75 to 625	150 to 700	C type: 0.2 D type: 0.4	C type: 0.1 D type: 0.2	C type: 0.3 D type: 0.6	3.1	5, 6, 10	191 to 741	Ø6h7	0.041

<sup>1</sup> Stroke with 1 short block (C type, without QZ).

<sup>2</sup> Value with 1 short block (C type, without QZ). This value is the sum of the rolling resistance value and seal resistance value.

Note: Refer to p. 75 for applicable couplings.

### Permissible Overhang Length<sup>3</sup>

Horizontal

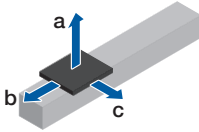

Wall-Mounted

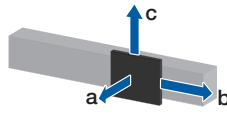

Vertical

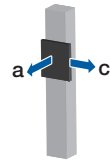

Estimated motor capacity 100 W	Ball screw lead (mm)	Load mass (kg)	a (mm)	b (mm)	c (mm)		
Direct coupling	C type	5	7.5	90	30	130	
			15.5	30	10	60	
			31	0	0	30	
		6	7	100	30	130	
			14	40	10	60	
			28	0	0	30	
	10	3.5	230	60	270		
		7	100	30	130		
		14	40	10	70		
		D type	5	11	600	210	170
				22	470	90	80
				44.5	220	40	40
6	11		600	210	170		
	22		470	90	80		
	44.5		220	40	40		
10	9	600	190	210			
	18.5	570	90	100			
	37.5	260	30	50			

Estimated motor capacity 100 W	Ball screw lead (mm)	Load mass (kg)	a (mm)	b (mm)	c (mm)		
Direct coupling	C type	5	3.5	230	70	410	
			7.5	90	30	190	
			15	30	10	90	
		6	3.5	230	70	420	
			7.5	90	30	190	
			15	30	10	90	
	10	2.5	340	90	590		
		5	190	40	290		
		10	70	10	110		
		D type	5	7	250	210	600
				14.5	110	100	340
				29	40	50	170
6	7		250	200	400		
	14.5		110	100	330		
	29		40	50	160		
10	5.5	330	260	600			
	11.5	140	120	420			
	23	60	50	210			

Estimated motor capacity 100 W	Ball screw lead (mm)	Load mass (kg)	a (mm)	c (mm)		
Direct coupling	C type	5	1	180	250	
			2	80	110	
			4.5	20	40	
		6	1	180	250	
			2	80	110	
			4.5	20	40	
	10	0.5	250	250		
		1.5	110	110		
		3.5	30	40		
		D type	5	3.5	600	320
				7	330	160
				14	150	80
6	3.5		600	320		
	7.5		310	150		
	15		140	70		
10	3	600	370			
	6	400	180			
	12	170	90			

<sup>3</sup> This is the value with the service life of the LM Guide limited to 5,000 km (for leads of 5 mm and 6 mm) or 10,000 km (for leads of 10 mm). The calculation conditions are as follows.  
Stroke: 350 mm (C type), 300 mm (D type) / Acceleration/deceleration: 0.3 G / Speed: 250 mm/s (for 5 mm lead), 300 mm/s (for 6 mm lead), 500 mm/s (for 10 mm lead) / Overhang direction: Loaded only in a single direction. Dimensions a, b, and c are from the center of the table's upper surface.

With Cover  
Direct Motor Coupling

Dimensions

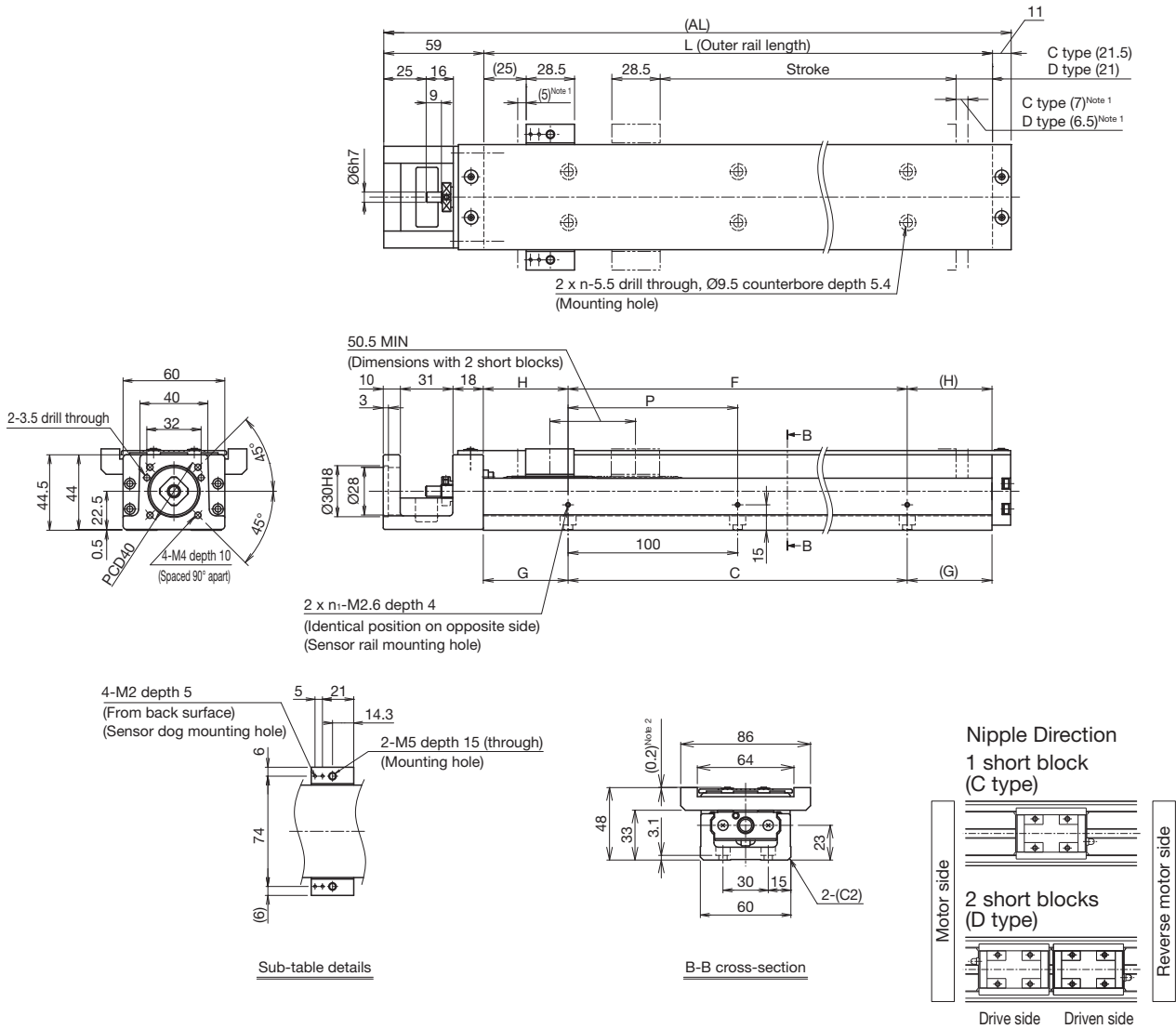

<sup>1</sup> Dimensions from the mechanical stopper to the stroke start position.  
<sup>2</sup> When designing the components that will be mounted to the sub-table, please note that the upper surface of the cover mounting bolts will be higher than the upper surface of the sub-table.

Stroke (mm) (Stroke between mechanical stoppers)	C type	75 (87)	125 (137)	225 (237)	325 (337)	425 (437)	525 (537)	625 (637)
	D type <sup>3</sup>	25 (36.5)	75 (86.5)	175 (186.5)	275 (286.5)	375 (386.5)	475 (486.5)	575 (586.5)
Maximum speed <sup>4</sup> (mm/s)	Ball screw lead: 5 mm	Normal grade/High accuracy grade		390		300	220	
		Precision grade		500		450	300	220
	Ball screw lead: 6 mm	Normal grade/High accuracy grade		470			360	260
		Precision grade		600		530	360	260
	Ball screw lead: 10 mm	Normal grade/High accuracy grade		790			600	430
		Precision grade		1,000		880	600	430
Dimensions (mm)	AL	220	270	370	470	570	670	770
	L	150	200	300	400	500	600	700
	C	100	100	200	300	400	500	600
	G	25	50	50	50	50	50	50
	P	100	100	200	200	200	200	200
	F	100	100	200	200	400	400	600
	H	25	50	50	100	50	100	50
No. of mounting holes	n	2	2	3	4	5	6	7
	n <sub>1</sub>	2	2	2	2	3	3	4
Mass <sup>5</sup> (kg)		1.9	2.3	3	3.8	4.6	5.3	6.1

<sup>3</sup> The value with 2 short blocks (D type, without QZ) attached.

<sup>4</sup> The maximum speed is restricted by the actuator's permissible speed.

<sup>5</sup> The mass with 2 short blocks (D type) has 0.3 kg added.



With Cover  
Motor Wrap

Dimensions

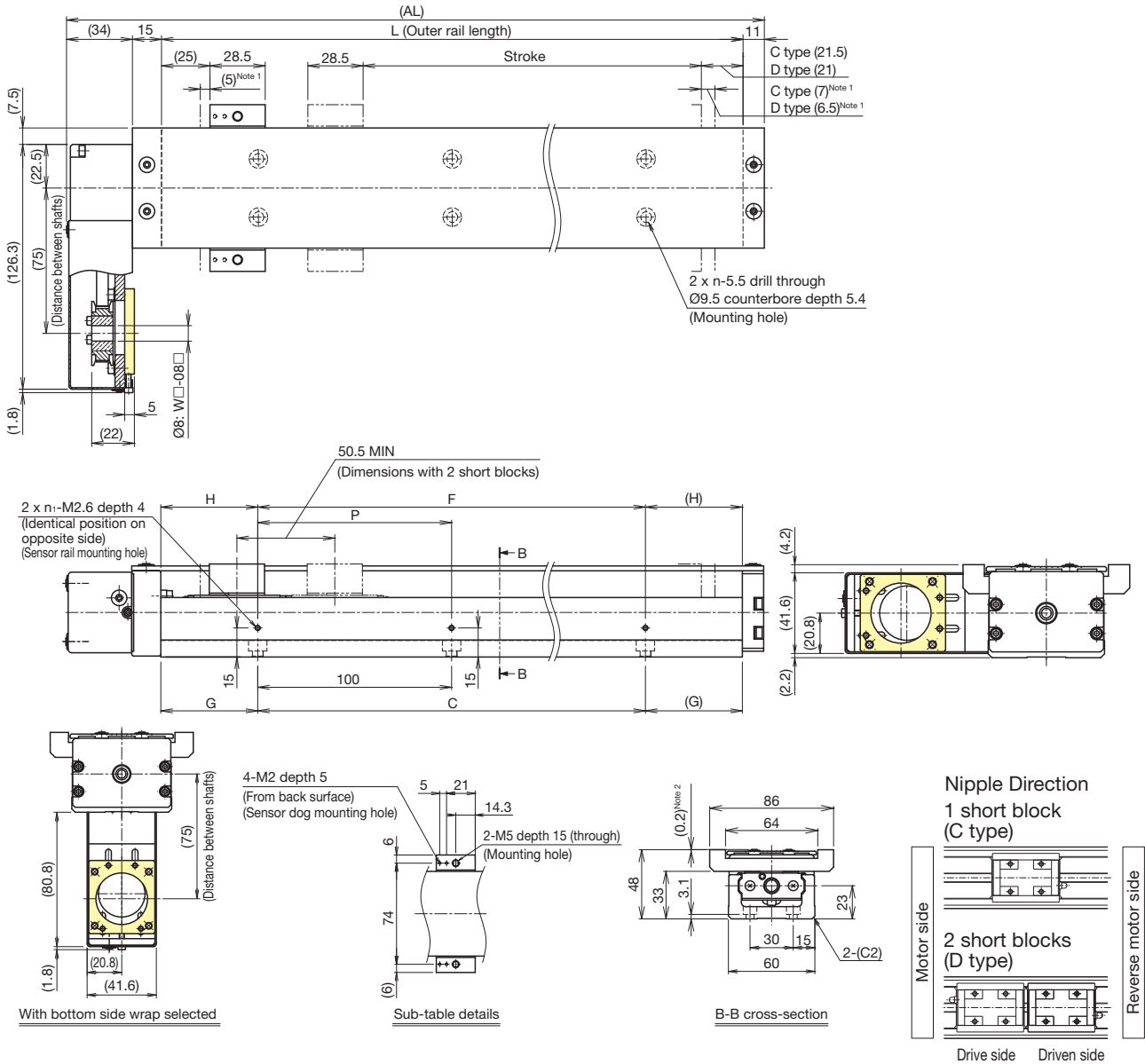

<sup>1</sup> Dimensions from the mechanical stopper to the stroke start position.  
<sup>2</sup> When designing the components that will be mounted to the sub-table, please note that the upper surface of the cover mounting bolts will be higher than the upper surface of the sub-table.

Stroke (mm) (Stroke between mechanical stoppers)	C type	75 (87)	125 (137)	225 (237)	325 (337)	425 (437)	525 (537)	625 (637)
	D type <sup>3</sup>	25 (36.5)	75 (86.5)	175 (186.5)	275 (286.5)	375 (386.5)	475 (486.5)	575 (586.5)
Maximum speed <sup>4</sup> (mm/s)	Ball screw lead: 5 mm	Normal grade/High accuracy grade		390		300		220
		Precision grade		500		450		300
	Ball screw lead: 6 mm	Normal grade/High accuracy grade		470		360		260
		Precision grade		600		530		360
Dimensions (mm)	Ball screw lead: 10 mm	Normal grade/High accuracy grade		790		600		430
		Precision grade		1,000		880		600
	AL	210	260	360	460	560	660	760
	L	150	200	300	400	500	600	700
No. of mounting holes	C	100	100	200	300	400	500	600
	G	25	50	50	50	50	50	50
	P	100	100	200	200	200	200	200
	F	100	100	200	200	400	400	600
	H	25	50	50	100	50	100	50
	n	2	2	3	4	5	6	7
Mass <sup>5</sup> (kg)	n <sub>1</sub>	2	2	2	2	3	3	4
	Mass <sup>5</sup> (kg)	2.2	2.6	3.3	4.1	4.9	5.6	6.4

<sup>3</sup> The value with 2 short blocks (D type, without QZ) attached.  
<sup>4</sup> The maximum speed is restricted by the actuator's permissible speed.  
<sup>5</sup> The mass with 2 short blocks (D type) has 0.3 kg added.

Without Cover  
Motor Wrap

Dimensions

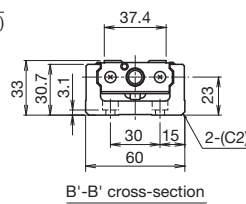
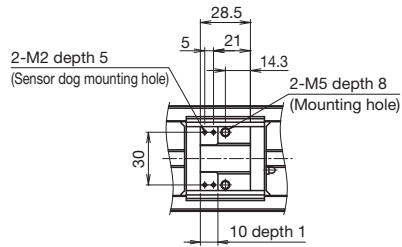
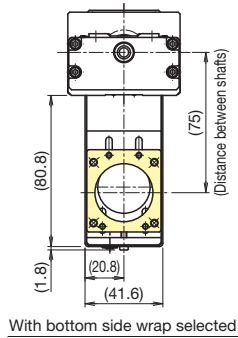
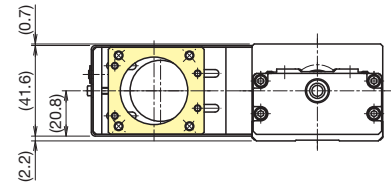
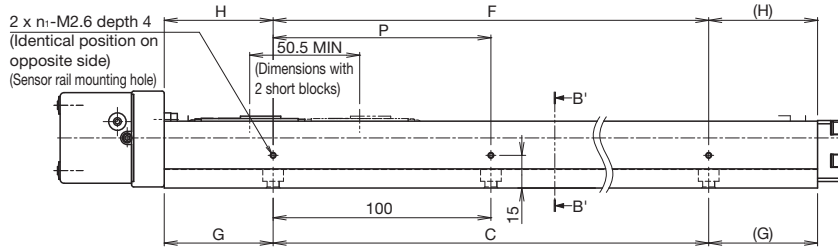
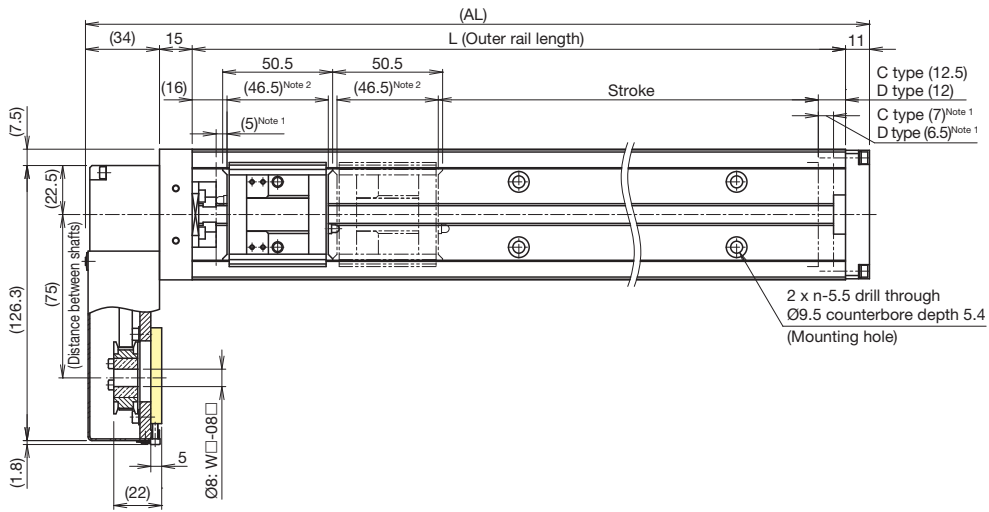

Nipple Direction  
1 short block  
(C type)

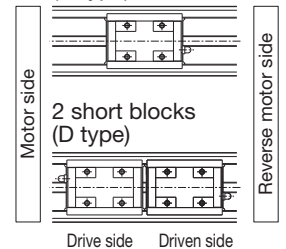

<sup>1</sup> Dimensions from the mechanical stopper to the stroke start position.  
<sup>2</sup> Shows the short block length when calculating the enabled stroke range.  
97.2 mm (2 blocks total) for KR33 with 2 short blocks (D type, without QZ).

Stroke (mm) (Stroke between mechanical stoppers)	C type		75 (87)	125 (137)	225 (237)	325 (337)	425 (437)	525 (537)	625 (637)
	D type <sup>3</sup>		25 (36.5)	75 (86.5)	175 (186.5)	275 (286.5)	375 (386.5)	475 (486.5)	575 (586.5)
Maximum speed <sup>4</sup> (mm/s)	Ball screw lead: 5 mm	Normal grade/High accuracy grade	390				450	300	220
		Precision grade	500				300	220	
	Ball screw lead: 6 mm	Normal grade/High accuracy grade	470				530	360	260
		Precision grade	600				360	260	
Ball screw lead: 10 mm	Normal grade/High accuracy grade	790				880	600	430	
	Precision grade	1,000				600	430		
Dimensions (mm)	AL		210	260	360	460	560	660	760
	L		150	200	300	400	500	600	700
	C		100	100	200	300	400	500	600
	G		25	50	50	50	50	50	50
	P		100	100	200	200	200	200	200
	F		100	100	200	200	400	400	600
	H		25	50	50	100	50	100	50
No. of mounting holes	n		2	2	3	4	5	6	7
	n <sub>1</sub>		2	2	2	2	3	3	4
Mass <sup>5</sup> (kg)		2		2.4	3.1	3.8	4.5	5.3	6

<sup>3</sup> The value with 2 short blocks (D type, without QZ) attached.  
<sup>4</sup> The maximum speed is restricted by the actuator's permissible speed.  
<sup>5</sup> The mass with 2 short blocks (D type) has 0.2 kg added.

# Options

## Sensors

Optional photo sensors and proximity sensors are available. Sensor-equipped models also feature a dedicated sensor rail and sensor dog.

Sensors, sensor rails, and sensor dogs can be mounted on both sides when the stroke is less than 70 mm.

Mounting example

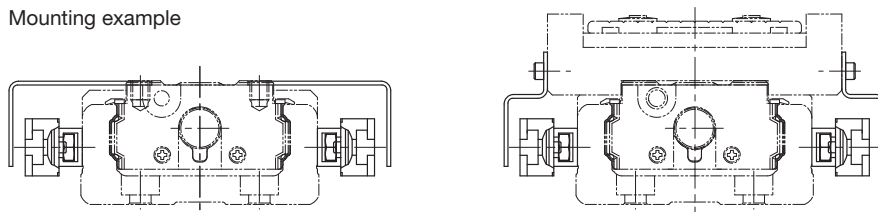

Symbol	Description	Model	Accessories
0	None	-	-
1	With sensor rail	-	Mounting screws, sensor rail (x1 or 2)
2	Photo sensor <sup>1</sup> (x3)	EE-SX671 (OMRON Corporation)	Mounting screws, nuts, sensor dog (x1 or 2), sensor rail (x1 or 2), mounting plates (x3), connectors (EE-1001 x3)
6	Photo sensor <sup>1</sup> (x3)	EE-SX674 (OMRON Corporation)	Mounting screws, nuts, sensor dog (x1 or 2), sensor rail (x1 or 2), mounting plates (x3), connectors (EE-1001 x3)
7	Proximity sensor N.O. contact <sup>2</sup> (x3)	APM-D3A1-001 (Azbil Corporation)	Mounting screws, nuts, sensor dog (x1 or 2), sensor rail (x1 or 2)
B	Proximity sensor N.C. contact <sup>3</sup> (x3)	APM-D3B1-003 (Azbil Corporation)	Mounting screws, nuts, sensor dog (x1 or 2), sensor rail (x1 or 2)
E	Proximity sensor N.O. contact <sup>2</sup> (x1) N.C. contact <sup>3</sup> (x2)	APM-D3A1-001 (Azbil Corporation) APM-D3B1-003 (Azbil Corporation)	Mounting screws, nuts, sensor dog (x1 or 2), sensor rail (x1 or 2)
H	Proximity sensor N.O. contact <sup>2</sup> (x3)	GX-F12A (Panasonic Industry Co., Ltd.)	Mounting screws, nuts, sensor dog (x1 or 2), sensor rail (x1 or 2)
L	Proximity sensor N.C. contact <sup>3</sup> (x3)	GX-F12B (Panasonic Industry Co., Ltd.)	Mounting screws, nuts, sensor dog (x1 or 2), sensor rail (x1 or 2)
J	Proximity sensor N.O. contact <sup>2</sup> (x1) N.C. contact <sup>3</sup> (x2)	GX-F12A (Panasonic Industry Co., Ltd.) GX-F12B (Panasonic Industry Co., Ltd.)	Mounting screws, nuts, sensor dog (x1 or 2), sensor rail (x1 or 2)
M	Proximity sensor N.O. contact <sup>2</sup> (x1) (PNP output) N.C. contact <sup>3</sup> (x2) (PNP output)	GX-F12A-P (Panasonic Industry Co., Ltd.) GX-F12B-P (Panasonic Industry Co., Ltd.)	Mounting screws, nuts, sensor dog (x1 or 2), sensor rail (x1 or 2)

<sup>1</sup> The photo sensors can be switched between ON when lit and ON when unlit.

<sup>2</sup> N.O. contact: Normally open contact point

<sup>3</sup> N.C. contact: Normally closed contact point

Notes: 1. If proximity sensors are close to one another, they may not function properly. If that happens, please prepare a type with a different frequency.

2. Mounting of sensors other than those in the table above is possible. Contact THK for details.

## Sensor Rail Mounting Dimensions

Mounting only a sensor rail is also possible.

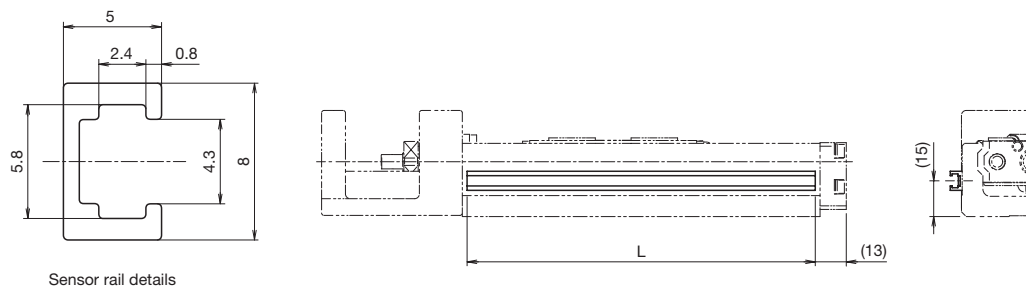

Stroke <sup>4</sup> (mm)	Outer rail length (mm)	L (mm)
50	150	146
100	200	196
200	300	296
300	400	396
400	500	496
500	600	596
600	700	696

<sup>4</sup> Stroke with 1 block (A type).

### Photo Sensor Mounting Dimensions

Connector: EE-1001 (OMRON Corporation) x3 included.  
To be mounted by the customer.

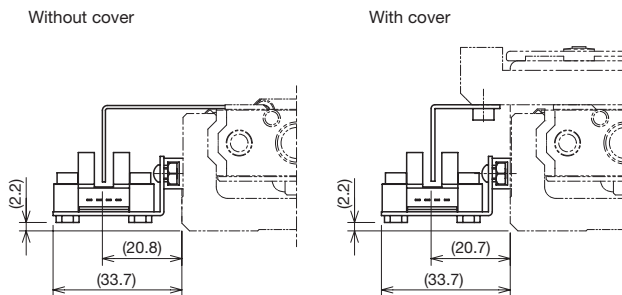

Symbol	Model	Manufacturer
2	EE-SX671	OMRON Corporation

Sensor dog width: 15 mm (10 mm)<sup>1</sup>

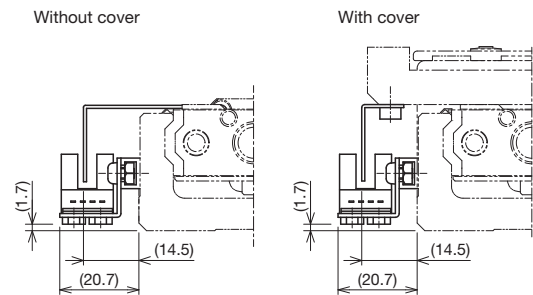

Symbol	Model	Manufacturer
6	EE-SX674	OMRON Corporation

Sensor dog width: 15 mm (10 mm)<sup>1</sup>

<sup>1</sup> The value in parentheses is for short block specifications.

### Proximity Sensor Mounting Dimensions

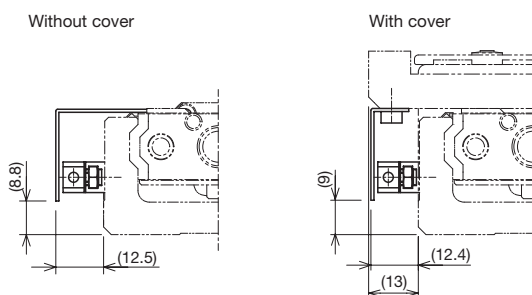

Symbol	Model	Manufacturer
7, B, E	APM-D3A1-001	Azbil Corporation
	APM-D3B1-003	

Sensor dog width: 15 mm (10 mm)<sup>2</sup>

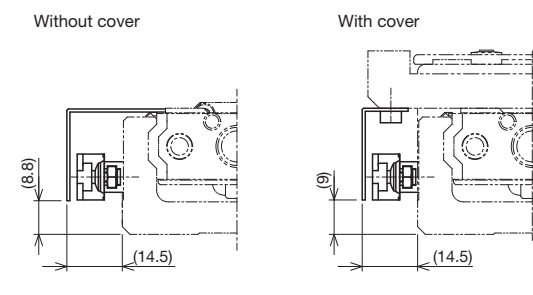

Symbol	Model	Manufacturer
H, L, J	GX-F12A	Panasonic Industry Co., Ltd.
	GX-F12B	
M	GX-F12A-P	
	GX-F12B-P	

Sensor dog width: 15 mm (10 mm)<sup>2</sup>

<sup>2</sup> The value in parentheses is for short block specifications.

# Options

## Intermediate Flange (Direct Coupling)

Several types of intermediate flanges for mounting motors are available.

When selecting "0" or "1" for Model Number Coding ⑦ With/without motor, specify an intermediate flange that matches the motor used.

Compatibility Table: Motors Used, Intermediate Flanges, and Couplings

Motor type	Manufacturer	Series	Motor model	Motor rated output (W)	Flange size	Housing A/ Intermediate flange	Compatible coupling models									
							MIKI PULLEY CO., LTD.	Nabeya Bi-tech Kaisha (NBK)								
AC servo motor	YASKAWA Electric Corporation	Σ-V	SGMJV-A5	50	40×40	AQ	SFC-020DA2-6B-8B	XGT2-19C-6-8								
			SGMAV-A5													
			SGMJV-01	100												
			SGMAV-01													
			SGMJV-C2	150												
			SGM7J-A5													
		Σ-7	SGM7A-A5	50	40×40	AQ	SFC-020DA2-6B-8B	XGT2-19C-6-8								
			SGM7J-01													
			SGM7A-01	100												
			SGM7J-C2													
			SGMJV-C2	150												
			SGM7J-C2													
	Σ-X	SGMXJ-A5	50	40×40	AQ	SFC-020DA2-6B-8B	XGT2-19C-6-8									
		SGMXA-A5														
		SGMXJ-01	100													
		SGMXA-01														
		SGMXJ-C2	150													
		SGMXA-C2														
	Mitsubishi Electric Corporation	MELSERVO	J4	HG-KR053	50	40×40	AQ	SFC-020DA2-6B-8B	XGT2-19C-6-8							
				HG-MR053												
				HG-KR13	100											
			HG-MR13													
			J5	HK-KT053W	50					40×40	AQ	SFC-020DA2-6B-8B	XGT2-19C-6-8			
				HK-KT13W												
		HF-KN053		100												
		HF-KN13														
		JN	TS4602	50	40×40	AQ	SFC-020DA2-6B-8B	XGT2-19C-6-8								
			TS4603													
			TS4604	100												
			TSM3102													
TSM3104	100															
TSM3104																
TAMAGAWA SEIKI CO., LTD.	TBL-III	A5	MSMD5A	50	38×38	AP	SFC-020DA2-6B-8B	XGT2-19C-6-8								
			MSME5A													
			MSMD01	100												
			MSME01													
			TBL-IV	A6					MSMF5A	50	38×38	AP	SFC-020DA2-6B-8B	XGT2-19C-6-8		
									MHMF5A							
	MSMF01	100			40×40	AQ	SFC-020DA2-6B-8B	XGT2-19C-6-8								
	MHMF01															
	SV-M005	50							40×40	AQ					SFC-020DA2-6B-8B	XGT2-19C-6-8
	SV-M010															
	SV2-M005	50	40×40	AQ							SFC-020DA2-6B-8B	XGT2-19C-6-8				
	SV2-M010															
SV2-M010	100	40×40			AQ	SFC-020DA2-6B-8B	XGT2-19C-6-8									
SV2-M010																
KEYENCE CORPORATION	SV							A5	SV-M005	50			40×40	AQ	SFC-020DA2-6B-8B	XGT2-19C-6-8
									SV-M010							
			SV2-M005	50												
SV2-M010																
SANYO DENKI CO., LTD.	SANMOTION R	A5	R2□A04005	50	40×40	AQ	SFC-020DA2-6B-8B	XGT2-19C-6-8								
			R2EA04008													
			R2□A04010	100												
R88M-K05030	50	40×40	AQ						SFC-020DA2-6B-8B	XGT2-19C-6-8						
R88M-K10030																
R88M-1M10030	100			40×40							AQ	SFC-020DA2-6B-8B	XGT2-19C-6-8			
R88M-1M10030																
OMRON Corporation	1S				A5	R88M-1M10030	100	40×40						AQ	SFC-020DA2-6B-8B	XGT2-19C-6-8
						R88M-1M10030										
FANUC CORPORATION	βis Series	A5	βis0.2/5000		50	40×40	AQ		SFC-020DA2-6B-8B	XGT2-19C-6-8						
			βis0.3/5000													
FANUC CORPORATION	βis Series	A5	βis0.3/5000	100	40×40						AQ	SFC-020DA2-6B-8B	XGT2-19C-6-8			
			βis0.3/5000													

Motor type	Manufacturer	Series	Motor model	Flange size	Housing A/ Intermediate flange	Compatible coupling models		
						MIKI PULLEY CO., LTD.	Nabeya Bi-tech Kaisha (NBK)	
Stepper motor	ORIENTAL MOTOR CO., LTD.	α step	AZ4*, AR4* (excluding AZM48)	42×42	AR	SFC-010DA2-6B-6B-L32	XGT2-15C-6-6	
			AZM48	42×42	AR	SFC-010DA2-6B-8B-L32	XGT2-19C-6-8	
			AZ6*, AR6*	60×60	AU	SFC-020DA2-6B-10B	XGT2-25C-6-10	
			CRK54*	42×42	AR	SFC-010DA2-5B-6B-L32	XGT2-15C-5-6	
			CRK56* (CRK569PM*)	60×60	AU	SFC-020DA2-6B-8B (SFC-020DA2-6B-10B)	XGT2-25C-6-8 (XGT2-25C-6-10)	
			RKS54*	42×42	AR	SFC-010DA2-6B-6B-L32	XGT2-15C-6-6	
		5-phase	RK II	RKS56*	60×60	AU	SFC-020DA2-6B-10B	XGT2-25C-6-10
				PKP54*	42×42	AR	SFC-010DA2-5B-6B-L32	XGT2-15C-5-6
				PKP56*	56.4×56.4	AT	SFC-020DA2-6B-8B	XGT2-19C-6-8
			PKP <sup>1</sup>	PKP56* (PKP569FM*)	60×60	AU	SFC-020DA2-6B-8B (SFC-020DA2-6B-10B)	XGT2-25C-6-8 (XGT2-25C-6-10)
				PKP24*	42×42	AR	SFC-010DA2-5B-6B-L32	XGT2-15C-5-6
				PKP26*	56.4×56.4	AT	SFC-020DA2-6B-8B	XGT2-25C-6-8
		KEYENCE CORPORATION	2-phase	QS-M42	42×42	AR	SFC-010DA2-5B-6B-L32	XGT2-15C-5-6
				QS-M60	60×60	AU	SFC-020DA2-6B-8B	XGT2-25C-6-8
		SANYO DENKI CO., LTD.	PB	PBDM423, PBA**423	42×42	AR	SFC-010DA2-6B-6B-L32	XGT2-15C-6-6
				PBDM60*, PBA**60*	60×60	AU	SFC-020DA2-6B-10B-L34	XGT2-25C-6-10
				FAF54*/FDF54*/FA511M42/FB511M42	42×42	AR	SFC-010DA2-6B-6B-L32	XGT2-15C-6-6
				FAM56*/FDM56*/FA512M60/FB512M60	60×60	AU	SFC-020DA2-6B-10B-L34	XGT2-25C-6-10
	5-phase		A5	DB14H52*	42×42	AR	SFC-010DA2-5B-6B-L32	XGT2-15C-5-6
				DU15H52*		AR	SFC-010DA2-5B-6B-L32	XGT2-15C-5-6
				D*16H71*	56×56	AT	SFC-020DA2-6B-6.35B-L34	XGT2-19C-6-6.35
				DB16H78*	60×60	AU	SFC-020DA2-6B-8B-L34	XGT2-25C-6-8

<sup>1</sup> Items in parentheses have different motor shaft diameters and require a coupling to be specified.  
 Notes: 1. The table shows only a portion of the model numbers for motors. For details regarding model numbers, please see the catalog for each respective motor manufacturer.  
 2. If the maximum torque for motors exceeds the permissible input torque (A/B → p. 61, C/D → p. 67), please consider a safety measure to limit the torque.  
 3. When installing a motor other than the motor model numbers listed above, contact THK.

### Housing A

KR33
A0

KR**	Actuator model
●	Housing A
◇	Intermediate flange

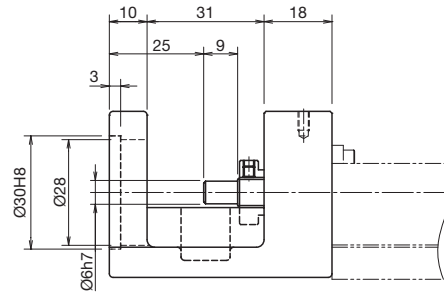
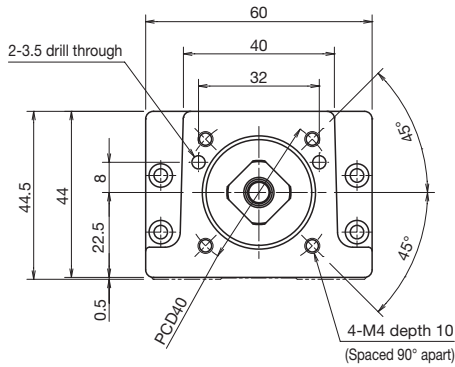

### Intermediate Flange

KR33
AP

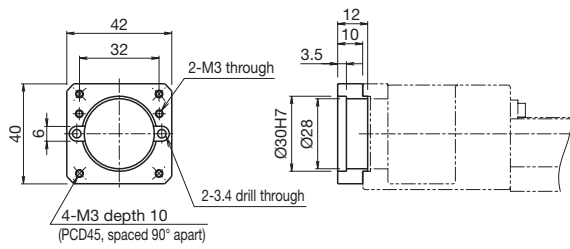

KR33
AQ

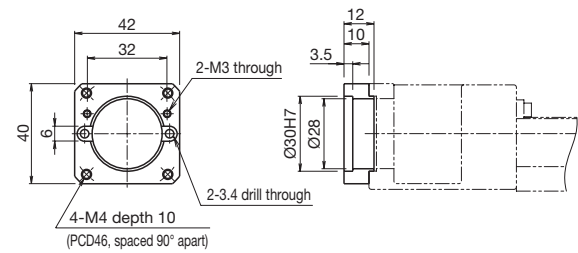

KR33
AR

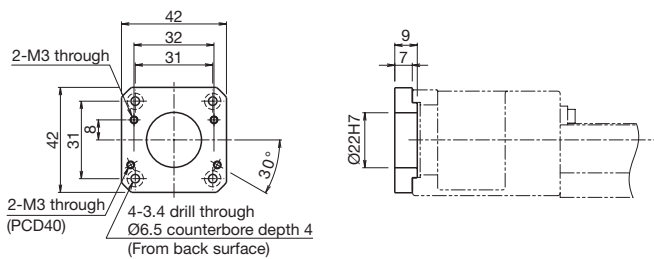

KR33
AT

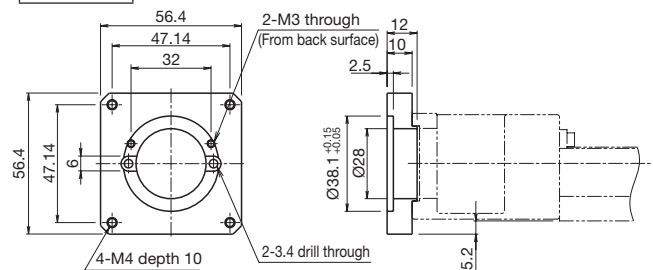

KR33
AU

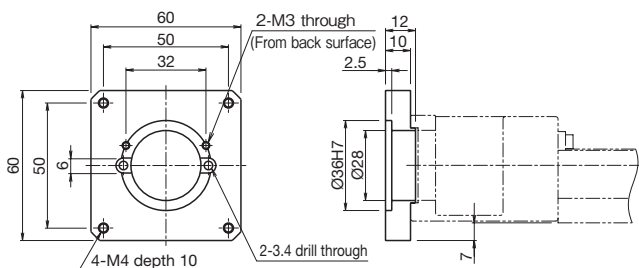

# Options

## Intermediate Flange (Motor Wrap)

Several types of intermediate flanges for mounting motors are available.

When selecting "R1," "R2," "R3," "R4," "R5," or "R6" for Model Number Coding ⑦ With/without motor, specify an intermediate flange that matches the motor used.

Symbol Coding

Motor wrap symbol ①	Intermediate flange ②	Motor shaft diameter (mm) ③	Motor shaft securing method ④
W	Q	08	D
W	Refer to the Compatibility Table: Motors Used and Motor Wrap Symbols below.	Specify a motor shaft diameter. (Refer to the Compatibility Table: Motors Used and Motor Wrap Symbols below.)	K: Key D: D-cut M: Friction tightening tool

Motor Shaft Securing Method

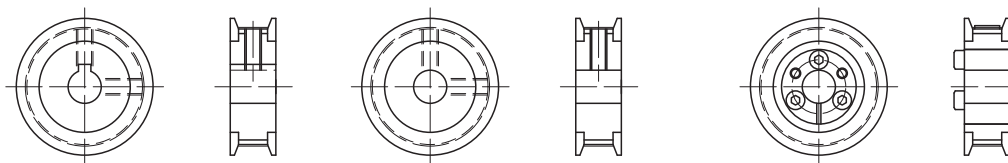

Key

D-cut

Friction tightening tool

Compatibility Table: Motors Used and Motor Wrap Symbols

Motor type	Manufacturer	Series	Motor model	Motor rated output (W)	Flange size	Housing A/Intermediate flange		
AC servo motor	YASKAWA Electric Corporation	Σ-V	SGMJV-A5	50	40×40	WQ-08K, WQ-08M		
			SGMAV-A5					
			SGMJV-01	100				
			SGMAV-01					
		SGMJV-C2	150					
		Σ-7	SGM7J-A5	50	40×40			
			SGM7A-A5					
			SGM7J-01	100				
			SGM7A-01					
		SGM7J-C2	150					
		Σ-X	SGMXJ-A5	50	40×40			
			SGMXA-A5					
	SGMXJ-01		100					
	SGMXA-01							
	SGMXJ-C2	150						
	Mitsubishi Electric Corporation	MELSERVO	J4	HG-KR053	50	40×40	WQ-08D, WQ-08M	
				HG-MR053				
				HG-KR13	100			
			HG-MR13					
			J5	HK-KT053W	50			40×40
				HK-KT13W	100			
	JN	HF-KN053	50	40×40				
		HF-KN13	100					
	TAMAGAWA SEIKI CO., LTD.	TBL-III	TS4602	50	40×40	WQ-08D, WQ-08M		
			TS4603	100				
			TS4604	150				
		TBL-IIV	TSM3102	50			40×40	
			TSM3104	100				
			MSMD5A	50				38×38
	MSME5A							
	Panasonic Corporation	MINAS	A5	MSMD01	100			
				MSME01				
				MSMF5A		50	38×38	
		A6	MHMF5A	50	40×40	WQ-08K, WQ-08M		
			MSMF01	100	38×38	WP-08K, WP-08M		
			MHMF01		40×40	WQ-08K, WQ-08M		
KEYENCE CORPORATION	SV	SV-M005	50	40×40	WQ-08K, WQ-08M			
		SV-M010	100					
	SV2	SV2-M005	50					
		SV2-M010	100					
SANYO DENKI CO., LTD.	SANMOTION R	R2□A04005	50	40×40	WQ-08M			
		R2EA04008	80					
		R2□A04010	100					
OMRON Corporation	OMNUC G5	R88M-K05030	50	40×40	WQ-08K, WQ-08M			
		R88M-K10030	100					
	1S	R88M-1M10030	100			40×40	WQ-08K, WQ-08M	

Notes: 1. The table shows only a portion of the model numbers for motors. For details regarding model numbers, please see the catalog for each respective motor manufacturer.  
 2. If the maximum torque for motors exceeds the permissible input torque (A/B → p. 61, C/D → p. 67), please consider a safety measure to limit the torque.  
 3. When installing a motor other than the motor model numbers listed above, contact THK.

### Motor Wrap Housing A

KR33
40

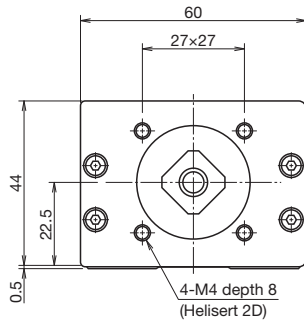

KR**	Actuator model
● ◇	●: Housing A ◇: Intermediate flange

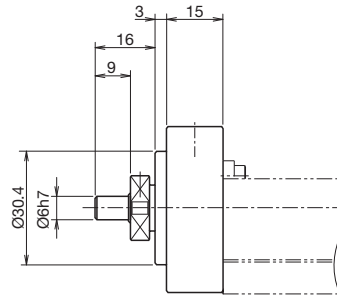

Note: The shaft end must be considered separately with motor wrap types. Contact THK for details.

### Motor Wrap Specification (Intermediate Flange)

KR33
WQ

Thickness: 5 mm

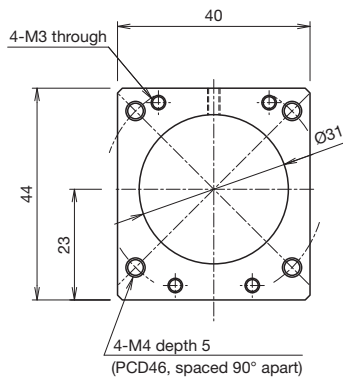

KR33
WP

Thickness: 5 mm

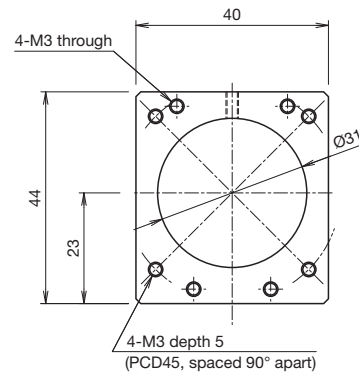

KR**	Actuator model
W□	□: Intermediate flange

## Options

### QZ Lubricator

The QZ Lubricator for KR feeds the right amount of lubricant to the outer rail and ball screw shaft raceways. This allows an oil film to be constantly formed between the balls and the raceway, and it significantly extends the lubrication maintenance interval.

Note 1: QZ cannot be selected when 5 mm lead is selected.

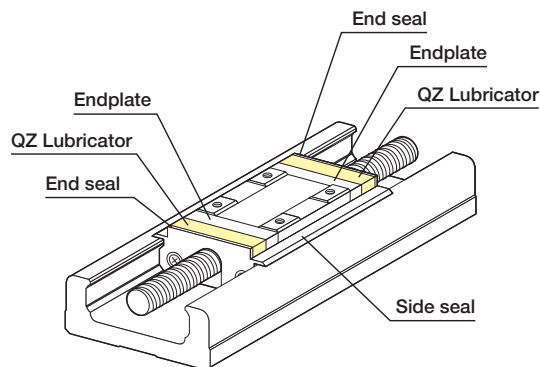

Appearance

### Features

- Since it compensates for oil loss, the lubrication maintenance interval can be significantly extended.
- It is an eco-friendly lubrication system that does not contaminate the surrounding area, as it feeds the right amount of lubricant to the ball raceway.

### QZ Configuration

Symbol	Block type	Description
QZ	A/B/C/D	QZ all-block double-sided specification
QZA	A/C	QZ fixed side specification
QZB	A/C	QZ supported side specification
QZAD	B/D	QZ fixed side (drive side block) + QZ supported side (driven side block) specification

Note 2: QZ specification types do not have a grease nipple mounted. Contact THK if a grease nipple is required.

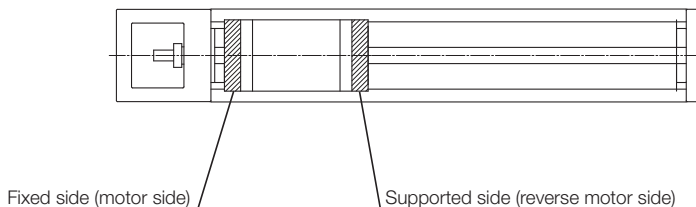

Block type \ QZ configuration	QZ	QZA	QZB	QZAD
A type (1 block)	 Fixed side      Supported side	 Fixed side	 Supported side	-
B type (2 blocks)	 Fixed side      Supported side	-	-	 Fixed side      Supported side
C type (1 short block)	 Fixed side      Supported side	 Fixed side	 Supported side	-
D type (2 short blocks)	 Fixed side      Supported side	-	-	 Fixed side      Supported side

### Dimensions with QZ Lubricator

QZ (With Cover)  
Block Type: A/B/C/D

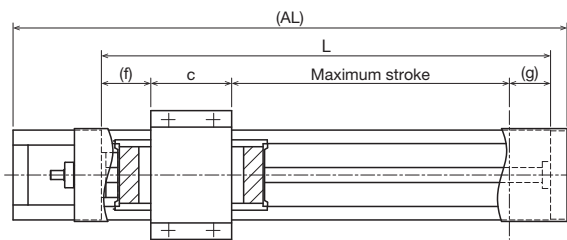

Block Type A/C

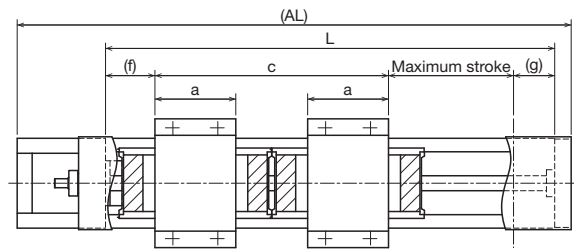

Block Type B/D

Unit: mm

Block type	Overall length AL	Outer rail length L	Stroke <sup>1</sup>	Maximum stroke <sup>1</sup>	a	c	f	g
A	270	200	75	85.5	-	54	33	27.5
	370	300	175	185.5				
	470	400	275	285.5				
	570	500	375	385.5				
	670	600	475	485.5				
	770	700	575	585.5				
B	370	300	70	83.5	54	156	33	27.5
	470	400	170	183.5				
	570	500	270	283.5				
	670	600	370	383.5				
	770	700	470	483.5				
C	220	150	50	61	-	28.5	33	27.5
	270	200	100	111				
	370	300	200	211				
	470	400	300	311				
	570	500	400	411				
	670	600	500	511				
	770	700	600	611				
D	370	300	125	134.5	28.5	105	33	27.5
	470	400	225	234.5				
	570	500	325	334.5				
	670	600	425	434.5				
	770	700	525	534.5				

<sup>1</sup> The value for B/D block types is with 2 blocks attached.

## Options

### Dimensions with QZ Lubricator

QZ (Without Cover)  
Block Type: A/B/C/D

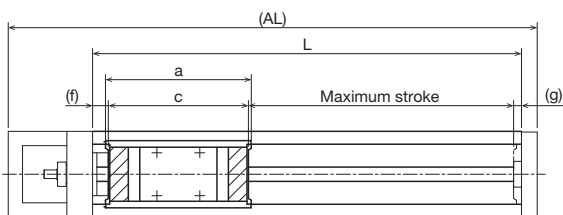

Block Type A/C

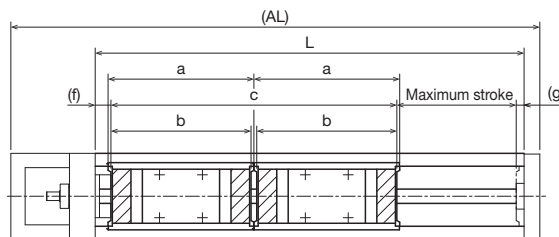

Block Type B/D

Unit: mm

Block type	Overall length AL	Outer rail length L	Stroke <sup>1</sup>	Maximum stroke <sup>1</sup>	a	b	c	f	g
A	270	200	75	85.5	102	-	98	11	5.5
	370	300	175	185.5					
	470	400	275	285.5					
	570	500	375	385.5					
	670	600	475	485.5					
	770	700	575	585.5					
B	370	300	70	83.5	102	98	200	11	5.5
	470	400	170	183.5					
	570	500	270	283.5					
	670	600	370	383.5					
	770	700	470	483.5					
C	220	150	50	61	76.5	-	72.5	11	5.5
	270	200	100	111					
	370	300	200	211					
	470	400	300	311					
	570	500	400	411					
	670	600	500	511					
	770	700	600	611					
D	370	300	125	134.5	76.5	72.5	149	11	5.5
	470	400	225	234.5					
	570	500	325	334.5					
	670	600	425	434.5					
	770	700	525	534.5					

<sup>1</sup> The value for B/D block types is with 2 blocks attached.

### Dimensions with QZ Lubricator

**QZA (With Cover)**  
Block Type: A/C

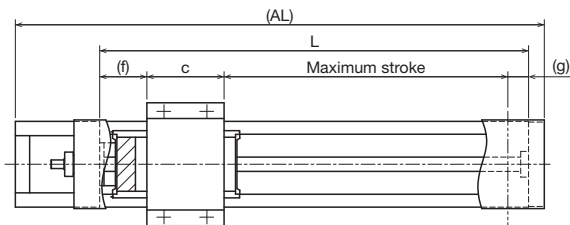

Block Type A/C

**QZA (Without Cover)**  
Block Type: A/C

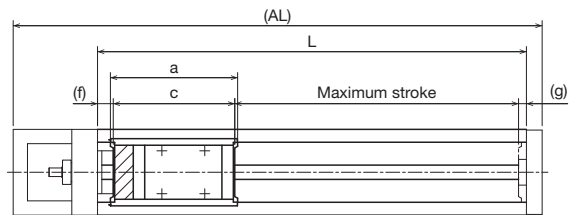

Block Type A/C

**QZA (With Cover)**

Unit: mm

Block type	Overall length AL	Outer rail length L	Stroke	Maximum stroke	c	f	g
A	270	200	85	98.5	54	33	14.5
	370	300	185	198.5			
	470	400	285	298.5			
	570	500	385	398.5			
	670	600	485	498.5			
	770	700	585	598.5			
C	220	150	60	74	28.5	33	14.5
	270	200	110	124			
	370	300	210	224			
	470	400	310	324			
	570	500	410	424			
	670	600	510	524			
	770	700	610	624			

Note 1: B/D block types cannot be selected for QZA.

**QZA (Without Cover)**

Unit: mm

Block type	Overall length AL	Outer rail length L	Stroke	Maximum stroke	a	c	f	g
A	270	200	85	98.5	89	85	11	5.5
	370	300	185	198.5				
	470	400	285	298.5				
	570	500	385	398.5				
	670	600	485	498.5				
	770	700	585	598.5				
C	220	150	60	74	63.5	59.5	11	5.5
	270	200	110	124				
	370	300	210	224				
	470	400	310	324				
	570	500	410	424				
	670	600	510	524				
	770	700	610	624				

Note 2: B/D block types cannot be selected for QZA.

## Options

### Dimensions with QZ Lubricator

QZB (With Cover)  
Block Type: A/C

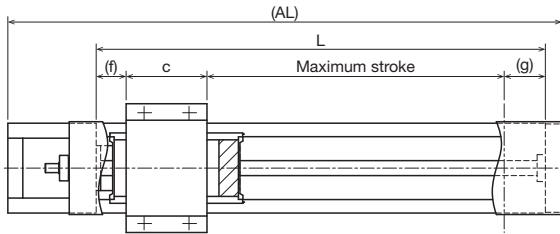

Block Type A/C

QZB (Without Cover)  
Block Type: A/C

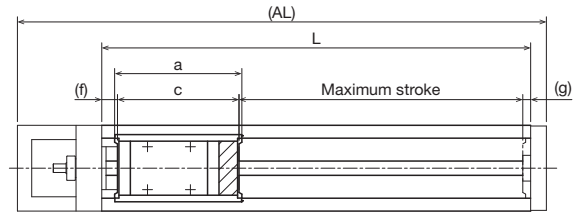

Block Type A/C

QZB (With Cover)

Unit: mm

Block type	Overall length AL	Outer rail length L	Stroke	Maximum stroke	c	f	g
A	270	200	85	98.5	54	20	27.5
	370	300	185	198.5			
	470	400	285	298.5			
	570	500	385	398.5			
	670	600	485	498.5			
	770	700	585	598.5			
C	220	150	60	74	28.5	20	27.5
	270	200	110	124			
	370	300	210	224			
	470	400	310	324			
	570	500	410	424			
	670	600	510	524			
	770	700	610	624			

Note 1: B/D block types cannot be selected for QZB.

QZB (Without Cover)

Unit: mm

Block type	Overall length AL	Outer rail length L	Stroke	Maximum stroke	a	c	f	g
A	270	200	85	98.5	89	85	11	5.5
	370	300	185	198.5				
	470	400	285	298.5				
	570	500	385	398.5				
	670	600	485	498.5				
	770	700	585	598.5				
C	220	150	60	74	63.5	59.5	11	5.5
	270	200	110	124				
	370	300	210	224				
	470	400	310	324				
	570	500	410	424				
	670	600	510	524				
	770	700	610	624				

Note 2: B/D block types cannot be selected for QZB.

### Dimensions with QZ Lubricator

#### QZAD (With Cover)

Block Type: B/D

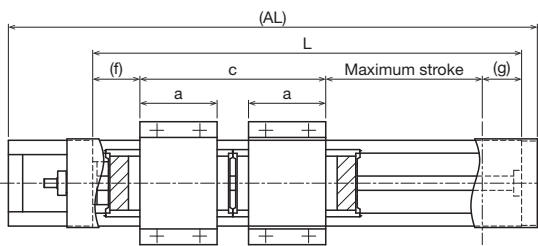

Block Type B/D

#### QZAD (Without Cover)

Block Type: B/D

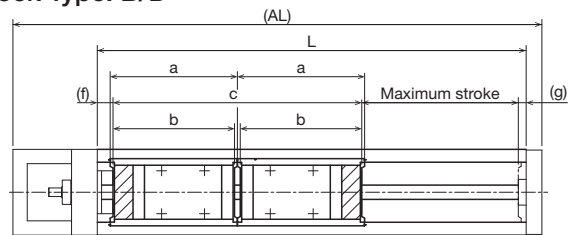

Block Type B/D

#### QZAD (With Cover)

Unit: mm

Block type	Overall length AL	Outer rail length L	Stroke <sup>1</sup>	Maximum stroke <sup>1</sup>	a	c	f	g
B	370	300	100	109.5	54	130	33	27.5
	470	400	200	209.5				
	570	500	300	309.5				
	670	600	400	409.5				
	770	700	500	509.5				
D	270	200	50	60.5	28.5	79	33	27.5
	370	300	150	160.5				
	470	400	250	260.5				
	570	500	350	360.5				
	670	600	450	460.5				
	770	700	550	560.5				

<sup>1</sup> The value for B/D block types is with 2 blocks attached.

Note 1: A/C block types cannot be selected for QZAD.

#### QZAD (Without Cover)

Unit: mm

Block type	Overall length AL	Outer rail length L	Stroke <sup>2</sup>	Maximum stroke <sup>2</sup>	a	b	c	f	g
B	370	300	100	109.5	89	85	174	11	5.5
	470	400	200	209.5					
	570	500	300	309.5					
	670	600	400	409.5					
	770	700	500	509.5					
D	270	200	50	60.5	63.5	59.5	123	11	5.5
	370	300	150	160.5					
	470	400	250	260.5					
	570	500	350	360.5					
	670	600	450	460.5					
	770	700	550	560.5					

<sup>2</sup> The value for B/D block types is with 2 blocks attached.

Note 2: A/C block types cannot be selected for QZAD.

# KR45H A/B

Direct motor coupling

Motor wrap

Width 80 mm

Height 45 mm

Max. stroke 800 mm

## Model Number Coding

Model ①	Ball screw lead ②	Block type ③	Stroke ④	Accuracy grade ⑤	With/without motor ⑥	Cover ⑦	Sensors ⑧	Housing A/ Intermediate flange ⑨
KR45H	10	A	0200	P	0	1	2	A0
<b>KR45H</b>	<b>05: 5 mm</b>	<b>A: x1</b>	<b>0090: 90 mm</b> to <b>0800: 800 mm</b>	<b>No symbol:</b> Normal grade <b>H:</b> High accuracy grade <b>P:</b> Precision grade	<b>0:</b> Direct coupling <b>1:</b> Direct coupling (THK will purchase and mount the motor you specify.) <b>With motor wrap</b> <b>R1:</b> Non-standard side wrap (without motor) <b>R2:</b> Standard side wrap (without motor) <b>R3:</b> Bottom side wrap (without motor) <b>R4:</b> Non-standard side wrap (THK will purchase and mount the motor you specify.) <b>R5:</b> Standard side wrap (THK will purchase and mount the motor you specify.) <b>R6:</b> Bottom side wrap (THK will purchase and mount the motor you specify.)	<b>0:</b> Without cover <b>1:</b> With cover <b>2:</b> With bellows	<b>0</b> <b>1</b> <b>2</b> <b>6</b> <b>7</b> <b>B</b> <b>E</b> <b>H</b> <b>L</b> <b>J</b> <b>M</b>	<b>With direct coupling</b> <b>A0</b> <b>AU</b> <b>AY</b> <b>60</b> <b>With motor wrap</b> <b>WV-14M</b> <b>WY-11M</b> <b>WY-14M</b> <b>With direct coupling</b> → p. 99 <b>With motor wrap</b> → p. 101
			When selecting 2: With bellows for ⑦ Cover, specify the stroke with bellows. → p. 165 to p. 166			Sensor details → p. 97		
			When selecting "0": A coupling is not provided. Indicate when placing an order if a coupling is required.					
			When selecting "1," "R4," "R5," or "R6": The specified motor will be installed. Indicate the motor cable direction separately. Select ⑨ Intermediate flange to match the specified motor.					

### ③ Block Type

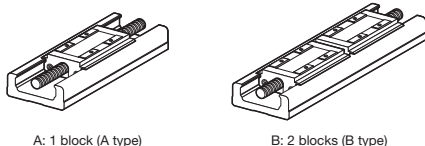

### ④ Motor Mounting Method

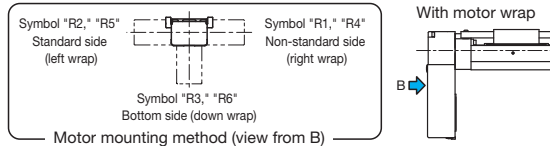

## Selection Information

### Basic Specifications

LM Guide	Basic dynamic load rating C (N)		26,700		
	Basic static load rating C <sub>0</sub> (N)		42,100		
	Radial clearance (mm)	Normal grade/High accuracy grade (H)	-0.006 to +0.003		
		Precision grade (P)	-0.016 to -0.006		
	Geometric moment of inertia	I <sub>x</sub> <sup>1</sup> (mm <sup>4</sup> )	8.4×10 <sup>4</sup>		
I <sub>y</sub> <sup>2</sup> (mm <sup>4</sup> )		8.9×10 <sup>5</sup>			
Mass (kg/m)		9			
Ball screw	Ball screw lead (mm)		5	10	20
	Basic dynamic load rating C <sub>a</sub> (N)	Normal grade/High accuracy grade (H)	5,500	3,140	3,040
		Precision grade (P)	4,100	2,940	3,430
	Basic static load rating C <sub>0a</sub> (N)	Normal grade/High accuracy grade (H)	13,900	6,760	7,150
		Precision grade (P)	6,960	3,720	5,290
	Screw shaft diameter (mm)		Ø16	Ø15	
	Thread minor diameter (mm)		Ø13.4	Ø12.4	
	Ball center-to-center diameter (mm)		Ø16.75	Ø15.75	
Permissible rotational speed <sup>3</sup> (min <sup>-1</sup> )	Normal grade/High accuracy grade (H)	2,980	3,170		
	Precision grade (P)	4,170	4,440		
Bearing unit (fixed side)	Axial direction	Basic dynamic load rating C <sub>a</sub> (N)	6,660		
		Static permissible load P <sub>0a</sub> (N)	3,240		
Permissible input torque (N·m)	Direct coupling	2.8	5.3		
	Motor wrap	2.8	4.5		
Static permissible moment <sup>4,5</sup> (N·m)		M <sub>x</sub> : 486 (2,732), M <sub>y</sub> : 486 (2,732), M <sub>z</sub> : 925 (1,850)			
Service life <sup>6</sup> (km)		5,000	10,000		
Standard grease/Grease nipple used		THK AFB-LF Grease/A-M6F			

- <sup>1</sup> I<sub>x</sub> is the geometric moment of inertia about the X axis.
  - <sup>2</sup> I<sub>y</sub> is the geometric moment of inertia about the Y axis.
  - <sup>3</sup> The permissible rotational speed may decrease as the stroke becomes longer.
  - <sup>4</sup> The value in parentheses is with 2 blocks (B type) attached.
  - <sup>5</sup> See p. 172 for the values if "1" or "2" is selected for item ⑦ in the Model Number Coding.
  - <sup>6</sup> Calculated under the following conditions:  
Stroke: 500 mm (A type), 390 mm (B type) / Speed: 240 mm/s (for 5 mm lead), 500 mm/s (for 10 mm lead), 1,000 mm/s (for 20 mm lead) / Load mass: Maximum load capacity (p. 9) / Acceleration/deceleration: As when set to maximum load capacity (p. 9) / Center of gravity: Center of the table's upper surface.
- Notes: 1. LM Guide load rating is the load rating per block.  
2. KR45H05, KR45H10 precision grade (P-grade) ball screws have integrated spacer balls with a 1:1 ratio.  
3. KR45H20 precision grade (P-grade) ball screws have integrated spacer balls with a 2:1 ratio.

### Geometric Moment of Inertia

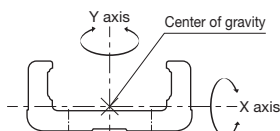

### Static Permissible Moment

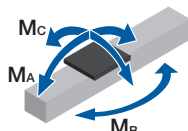

### Accuracy

Accuracy grade	Item	Stroke <sup>7</sup>						
		200	300	400	500	600	700	800
Normal grade (no symbol)	Positioning repeatability (mm)	±0.01						
	Positioning accuracy (mm)	Not specified						
	Running parallelism (vertical direction) (mm)	Not specified						
	Backlash (mm)	0.02						
	Starting torque (N·cm)	10						
High accuracy grade (H)	Positioning repeatability (mm)	±0.005						
	Positioning accuracy (mm)	0.06		0.12		0.15		
	Running parallelism (vertical direction) (mm)	0.03		0.04				
	Backlash (mm)	0.01						
	Starting torque (N·cm)	10						
Precision grade (P)	Positioning repeatability (mm)	±0.003				±0.005		
	Positioning accuracy (mm)	0.025		0.03		0.035		
	Running parallelism (vertical direction) (mm)	0.015		0.02		0.025		
	Backlash (mm)	0.003						
	Starting torque (N·cm)	15		17				

- <sup>7</sup> Stroke with 1 block (A type).
- Notes: 4. Precision evaluation in accordance with THK standards.  
5. Measured using a motor for inspection. With motor wrap specifications, measurements are not made in the completed motor wrap state.  
6. The starting torque represents the value when containing THK AFB-LF Grease.  
7. The starting torque may exceed standards if using vacuum grease, clean room grease, or other high-viscosity greases, so care should be taken when selecting a motor.  
8. Contact THK for accuracy higher than the standard stroke.

### Motor Selection Information

Stroke <sup>1</sup> (mm)	Outer rail length (mm)	LM Guide				Ball screw		Motor mounting part	
		Moving part mass (kg)			Sliding resistance value <sup>2</sup> (N)	Lead (mm)	Shaft length (mm)	Direct coupling	Motor wrap
		Block mass	Sub-table mass	Total mass				Shaft end diameter (mm)	Timing pulley (sum of two) Inertial moment x 10 <sup>-4</sup> (kg·m <sup>2</sup> )
200 to 800	340 to 940	A type: 1 B type: 2	A type: 0.4 B type: 0.8	A type: 1.4 B type: 2.8	5.1	5, 10, 20	403 to 1,003	Ø10h7	0.86

<sup>1</sup> Stroke with 1 block (A type).

<sup>2</sup> Value with 1 block (A type). This value is the sum of the rolling resistance value and seal resistance value.

Note: Refer to p. 99 for applicable couplings.

### Permissible Overhang Length<sup>3</sup>

Horizontal

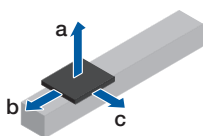

Wall-Mounted

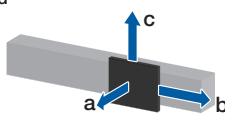

Vertical

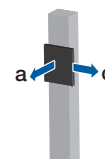

Estimated motor capacity 200 W	Ball screw lead (mm)	Load mass (kg)	a (mm)	b (mm)	c (mm)		
			Direct coupling	A type	5	16 230 80 70 32.5 90 30 30 65 20 10 10	10
Motor wrap	A type	5	22.5 800 270 100 45.5 410 130 50 91.5 180 60 20	10	22.5 800 270 100 45.5 410 130 50 91.5 180 60 20	20	4.5 800 800 530 9.5 800 640 250 19.5 800 310 120
			B type	5	16 230 80 70 32.5 90 30 30 65 20 10 10	10	16 230 80 70 32.5 90 30 30 65 20 10 10

Estimated motor capacity 200 W	Ball screw lead (mm)	Load mass (kg)	a (mm)	b (mm)	c (mm)		
			Direct coupling	A type	5	13 40 180 620 26 0 90 310 52 0 40 150	10
Motor wrap	A type	5	18 80 380 800 36.5 20 180 620 73.5 0 90 310	10	18 80 380 800 36.5 20 180 620 73.5 0 90 310	20	4.5 490 800 800 9.5 210 720 800 19.5 70 350 800
			B type	5	13 40 180 620 26 0 90 310 52 0 40 150	10	13 40 180 620 26 0 90 310 52 0 30 150

Estimated motor capacity 200 W	Ball screw lead (mm)	Load mass (kg)	a (mm)	c (mm)			
			Direct coupling	A type	5	8.5 80 210 17.5 20 100 43.5 0 50	10
Motor wrap	A type	5	10.5 410 500 21.5 180 240 43.5 70 120	10	5.5 800 800 11.5 370 460 23 160 230	20	2 800 800 4 800 800 8 550 660
			B type	5	4.5 180 410 9 70 200 18.5 10 100	10	4.5 180 410 9 70 200 18 10 100

Estimated motor capacity 400 W	Ball screw lead (mm)	Load mass (kg)	a (mm)	b (mm)	c (mm)		
			Direct coupling	A type	5	16 230 80 70 32.5 90 30 30 65 20 10 10	10
Motor wrap	A type	5	22.5 800 270 100 45.5 410 130 50 91.5 180 60 20	10	22.5 800 270 100 45.5 410 130 50 91.5 180 60 20	20	12 800 500 200 24 800 250 100 48.5 380 120 50
			B type	5	16 230 80 70 32.5 90 30 30 65 20 10 10	10	16 230 80 70 32.5 90 30 30 65 20 10 10

Estimated motor capacity 400 W	Ball screw lead (mm)	Load mass (kg)	a (mm)	b (mm)	c (mm)		
			Direct coupling	A type	5	13 40 180 620 26 0 90 310 52 0 40 150	10
Motor wrap	A type	5	18 80 380 800 36.5 20 180 620 73.5 0 90 310	10	18 80 380 800 36.5 20 180 620 73.5 0 90 310	20	12 150 570 800 24 50 280 800 48 0 140 470
			B type	5	13 40 180 620 26 0 90 310 52 0 40 150	10	13 40 180 620 26 0 90 310 52 0 30 150

Estimated motor capacity 400 W	Ball screw lead (mm)	Load mass (kg)	a (mm)	c (mm)			
			Direct coupling	A type	5	8.5 80 210 17.5 20 100 35.5 0 50	10
Motor wrap	A type	5	10.5 410 500 21.5 180 240 43.5 70 120	10	5.5 800 800 11.5 370 460 23 160 230	20	4.5 800 800 9 480 580 18.5 210 280
			B type	5	4.5 180 410 9 70 200 18.5 10 100	10	4.5 180 410 9 70 200 18 10 100

<sup>3</sup> This is the value with the service life of the LM Guide limited to 5,000 km (for 5 mm lead) or 10,000 km (for 10 mm or 20 mm lead). The calculation conditions are as follows.  
Stroke: 500 mm (A type), 390 mm (B type) / Acceleration/deceleration: 0.3 G / Speed: 240 mm/s (for 5 mm lead), 500 mm/s (for 10 mm lead), 1,000 mm/s (for 20 mm lead) / Overhang direction: Loaded only in a single direction. Dimensions a, b, and c are from the center of the table's upper surface.

With Cover  
Direct Motor Coupling

Dimensions

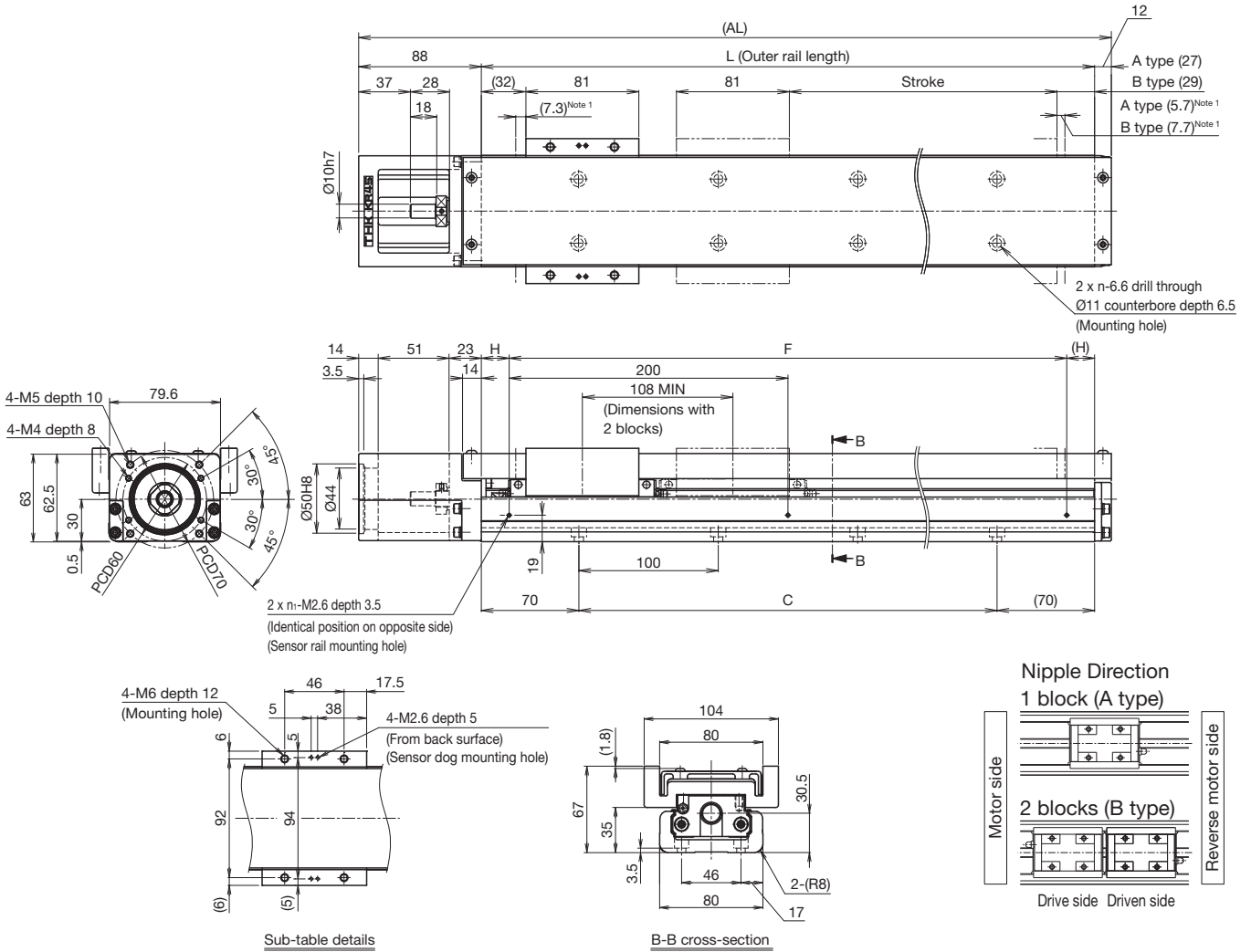

<sup>1</sup> Dimensions from the mechanical stopper to the stroke start position.

Stroke (mm) (Stroke between mechanical stoppers)	A type	200 (213)	300 (313)	400 (413)	500 (513)	600 (613)	700 (713)	800 (813)
	B type <sup>2</sup>	90 (105)	190 (205)	290 (305)	390 (405)	490 (505)	590 (605)	690 (705)
Maximum speed <sup>3</sup> (mm/s)	Ball screw lead: 5 mm	Normal grade/high accuracy grade		240		230		230
		Precision grade		340		290		230
	Ball screw lead: 10 mm	Normal grade/high accuracy grade		520		430		430
		Precision grade		740		730		550
Ball screw lead: 20 mm	Normal grade/high accuracy grade	1,050		840		840		840
	Precision grade	1,480		1,430		1,080		840
Dimensions (mm)	AL	440	540	640	740	840	940	1,040
	L	340	440	540	640	740	840	940
	C	200	300	400	500	600	700	800
	F	200	400	400	600	600	800	800
	H	70	20	70	20	70	20	70
No. of mounting holes	n	3	4	5	6	7	8	9
	n <sub>1</sub>	2	3	3	4	4	5	5
Mass <sup>4</sup> (kg)		6.4	7.6	8.7	9.9	11	12.2	13.3

<sup>2</sup> The value with 2 blocks (B type) attached.

<sup>3</sup> The maximum speed is restricted by the actuator's permissible speed.

<sup>4</sup> The mass with 2 blocks (B type) has 1.4 kg added.

Without Cover  
Direct Motor Coupling

**Dimensions**

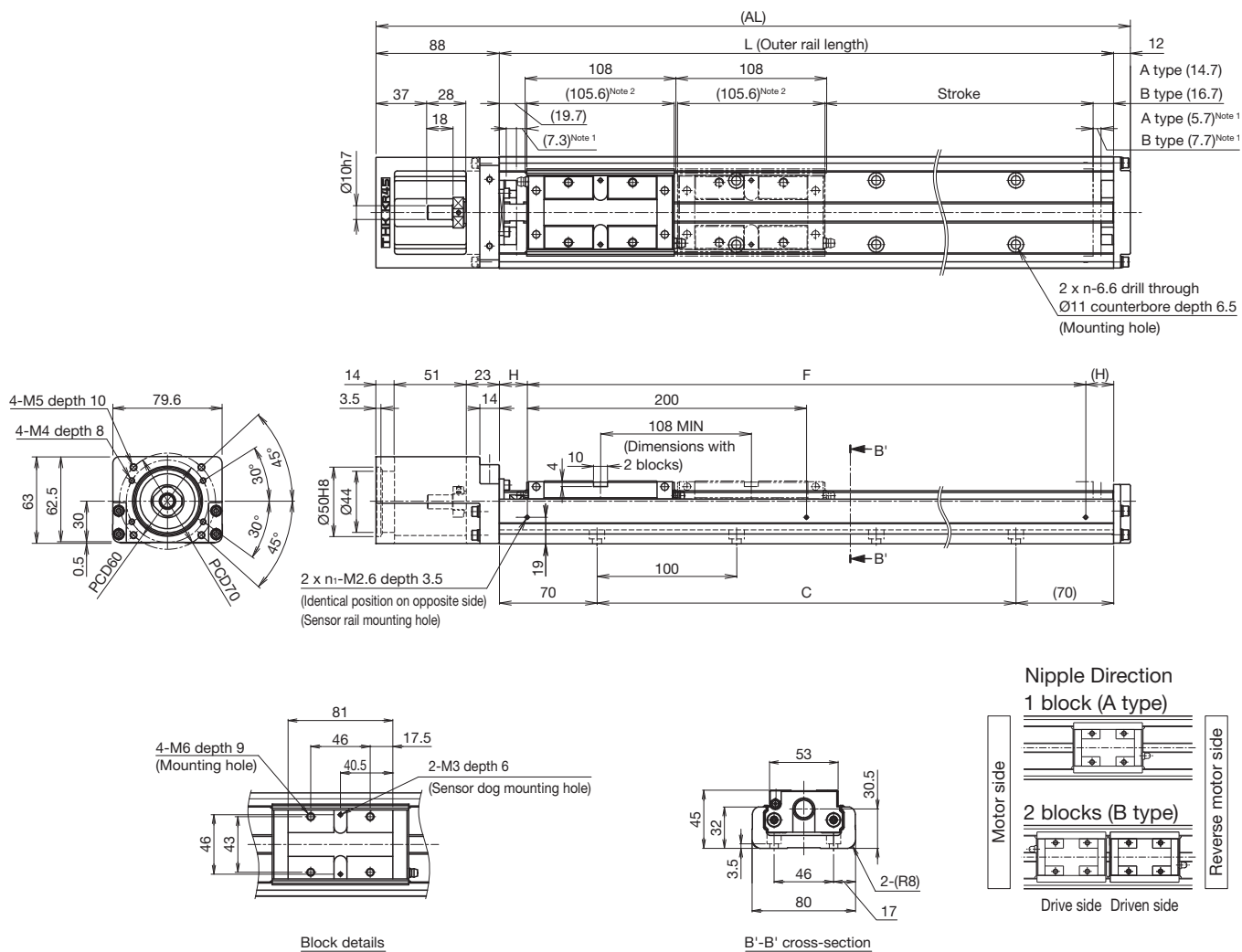

<sup>1</sup> Dimensions from the mechanical stopper to the stroke start position.  
<sup>2</sup> Shows the block length when calculating the enabled stroke range.  
213.6 mm (2 blocks total) for KR45H with 2 blocks (B type).

Stroke (mm)	A type	200 (213)	300 (313)	400 (413)	500 (513)	600 (613)	700 (713)	800 (813)
(Stroke between mechanical stoppers)	B type <sup>3</sup>	90 (105)	190 (205)	290 (305)	390 (405)	490 (505)	590 (605)	690 (705)
Maximum speed <sup>4</sup> (mm/s)	Ball screw lead: 5 mm	Normal grade/high accuracy grade		240		230		230
		Precision grade		340		290		230
	Ball screw lead: 10 mm	Normal grade/high accuracy grade		520		430		430
		Precision grade		740		730		550
Ball screw lead: 20 mm	Normal grade/high accuracy grade	1,050		840		840		840
	Precision grade	1,480		1,430		1,080		840
Dimensions (mm)	AL	440	540	640	740	840	940	1,040
	L	340	440	540	640	740	840	940
	C	200	300	400	500	600	700	800
	F	200	400	400	600	600	800	800
	H	70	20	70	20	70	20	70
No. of mounting holes	n	3	4	5	6	7	8	9
	n <sub>1</sub>	2	3	3	4	4	5	5
Mass <sup>5</sup> (kg)		5.4	6.5	7.5	8.6	9.7	10.7	11.8

<sup>3</sup> The value with 2 blocks (B type) attached.  
<sup>4</sup> The maximum speed is restricted by the actuator's permissible speed.  
<sup>5</sup> The mass with 2 blocks (B type) has 1 kg added.

With Cover  
Motor Wrap

Dimensions

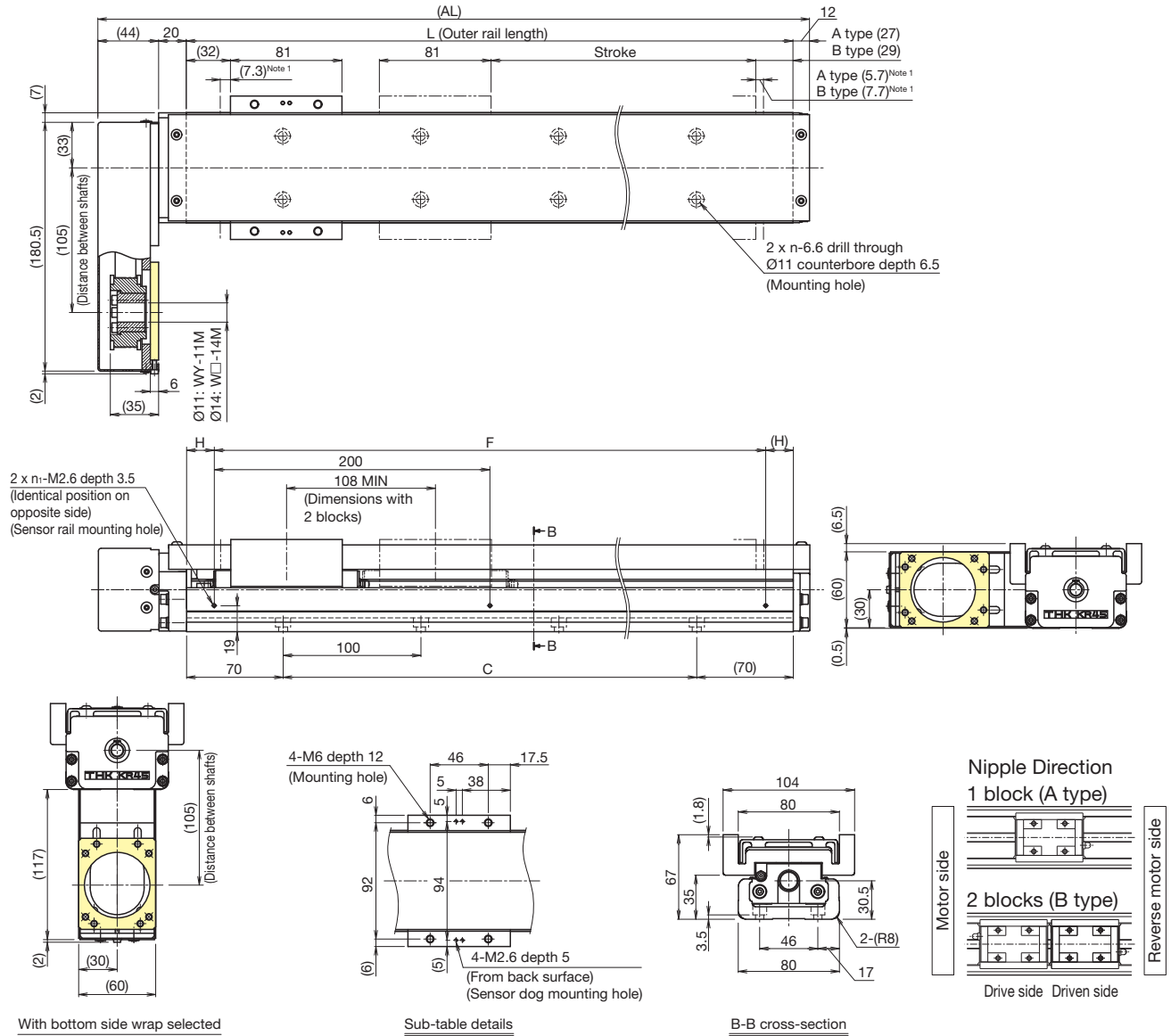

<sup>1</sup> Dimensions from the mechanical stopper to the stroke start position.

Stroke (mm) (Stroke between mechanical stoppers)	A type	200 (213)	300 (313)	400 (413)	500 (513)	600 (613)	700 (713)	800 (813)	
	B type <sup>2</sup>	90 (105)	190 (205)	290 (305)	390 (405)	490 (505)	590 (605)	690 (705)	
Maximum speed <sup>3</sup> (mm/s)	Ball screw lead: 5 mm	Normal grade/high accuracy grade	240						230
		Precision grade	340						230
	Ball screw lead: 10 mm	Normal grade/high accuracy grade	520						430
		Precision grade	740						430
Ball screw lead: 20 mm	Normal grade/high accuracy grade	1,050						840	
	Precision grade	1,480						840	
Dimensions (mm)	AL	416	516	616	716	816	916	1,016	
	L	340	440	540	640	740	840	940	
	C	200	300	400	500	600	700	800	
	F	200	400	400	600	600	800	800	
	H	70	20	70	20	70	20	70	
No. of mounting holes	n	3	4	5	6	7	8	9	
	n <sub>1</sub>	2	3	3	4	4	5	5	
Mass <sup>4</sup> (kg)		7.4	8.5	9.7	10.8	12	13.1	14.2	

<sup>2</sup> The value with 2 blocks (B type) attached.  
<sup>3</sup> The maximum speed is restricted by the actuator's permissible speed.  
<sup>4</sup> The mass with 2 blocks (B type) has 1.4 kg added.

Without Cover  
Motor Wrap

Dimensions

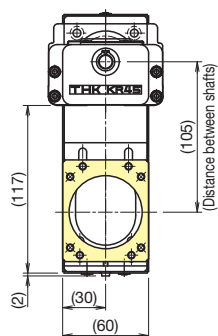
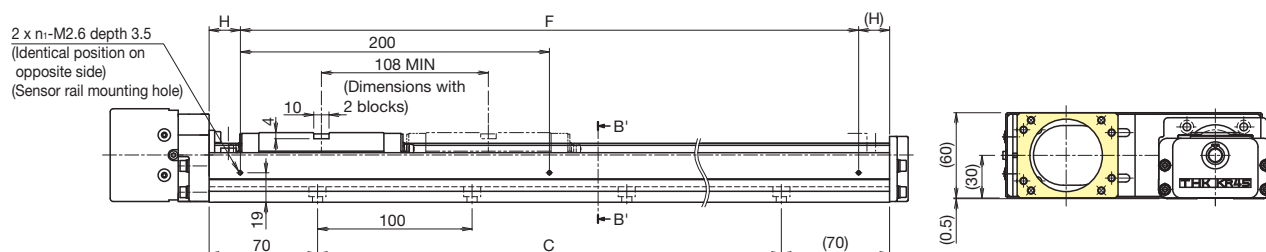
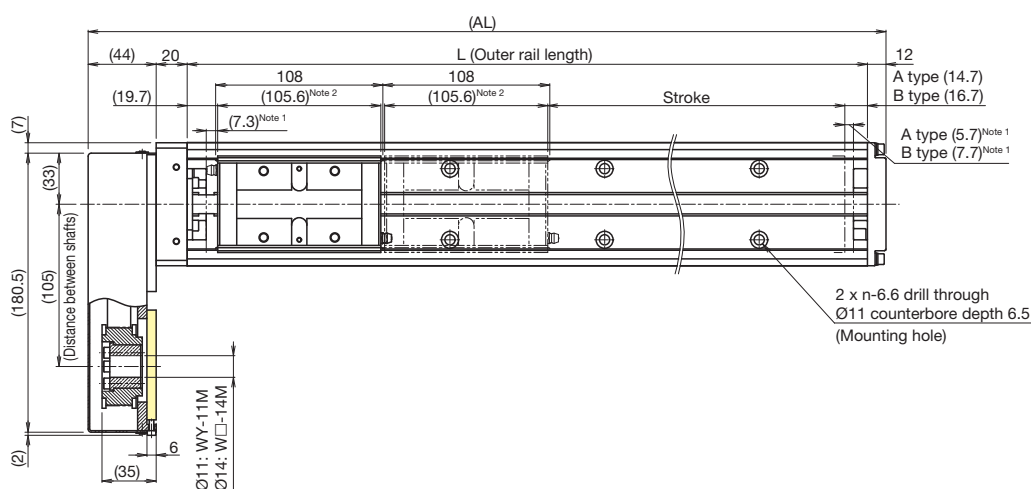

With bottom side wrap selected

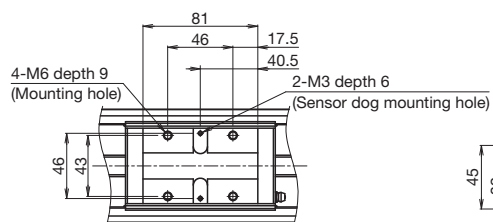

Block details

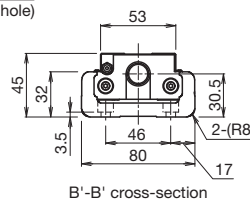

B'-B' cross-section

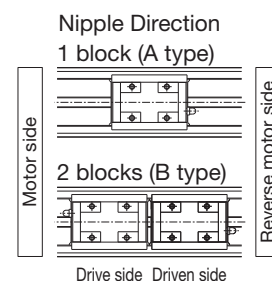

<sup>1</sup> Dimensions from the mechanical stopper to the stroke start position.  
<sup>2</sup> Shows the block length when calculating the enabled stroke range.  
213.6 mm (2 blocks total) for KR45H with 2 blocks (B type).

Stroke (mm) (Stroke between mechanical stoppers)	A type	200 (213)	300 (313)	400 (413)	500 (513)	600 (613)	700 (713)	800 (813)	
	B type <sup>3</sup>	90 (105)	190 (205)	290 (305)	390 (405)	490 (505)	590 (605)	690 (705)	
Maximum speed <sup>4</sup> (mm/s)	Ball screw lead: 5 mm	Normal grade/high accuracy grade						240	230
		Precision grade						340	290
	Ball screw lead: 10 mm	Normal grade/high accuracy grade						520	430
		Precision grade						740	430
Ball screw lead: 20 mm	Normal grade/high accuracy grade						1,050	840	
	Precision grade						1,480	840	
Dimensions (mm)	AL	416	516	616	716	816	916	1,016	
	L	340	440	540	640	740	840	940	
	C	200	300	400	500	600	700	800	
	F	200	400	400	600	600	800	800	
	H	70	20	70	20	70	20	70	
No. of mounting holes	n	3	4	5	6	7	8	9	
	n <sub>1</sub>	2	3	3	4	4	5	5	
Mass <sup>5</sup> (kg)		6.4	7.4	8.5	9.5	10.6	11.7	12.7	

<sup>3</sup> The value with 2 blocks (B type) attached.

<sup>4</sup> The maximum speed is restricted by the actuator's permissible speed.

<sup>5</sup> The mass with 2 blocks (B type) has 1 kg added.

# KR45H C/D

Direct motor coupling

Motor wrap

Width 80 mm

Height 45 mm

Max. stroke 830 mm

## Model Number Coding

Model ①	Ball screw lead ②	Block type ③	Stroke ④	Accuracy grade ⑤	With/without motor ⑥	Cover ⑦	Sensors ⑧	Housing A/ Intermediate flange ⑨
KR45H	10	C	0230	P	0	1	2	A0
<b>KR45H</b>	<b>05:</b> 5 mm <b>10:</b> 10 mm <b>20:</b> 20 mm	<b>C:</b> x1 <b>D:</b> x2	<b>0160:</b> 160 mm to <b>0830:</b> 830 mm	<b>No symbol:</b> Normal grade <b>H:</b> High accuracy grade <b>P:</b> Precision grade	<b>0:</b> Direct coupling <b>1:</b> Direct coupling (THK will purchase and mount the motor you specify.) <b>With motor wrap</b> <b>R1:</b> Non-standard side wrap (without motor) <b>R2:</b> Standard side wrap (without motor) <b>R3:</b> Bottom side wrap (without motor) <b>R4:</b> Non-standard side wrap (THK will purchase and mount the motor you specify.) <b>R5:</b> Standard side wrap (THK will purchase and mount the motor you specify.) <b>R6:</b> Bottom side wrap (THK will purchase and mount the motor you specify.)	<b>0:</b> Without cover <b>1:</b> With cover <b>2:</b> With bellows	<b>0</b> <b>1</b> <b>2</b> <b>6</b> <b>7</b> <b>B</b> <b>E</b> <b>H</b> <b>L</b> <b>J</b> <b>M</b>	<b>With direct coupling</b> <b>A0</b> <b>AU</b> <b>AY</b> <b>60</b> <b>With motor wrap</b> <b>WV-14M</b> <b>WY-11M</b> <b>WY-14M</b> <b>With direct coupling</b> → p. 99 <b>With motor wrap</b> → p. 101
			When selecting 2: With bellows for ⑦ Cover, specify the stroke with bellows. → p. 167 to p. 168			When selecting "0": A coupling is not provided. Indicate when placing an order if a coupling is required.		
			When selecting "1," "R4," "R5," or "R6": The specified motor will be installed. Indicate the motor cable direction separately. Select ⑨ Intermediate flange to match the specified motor.			Sensor details → p. 97		

### ③ Block Type

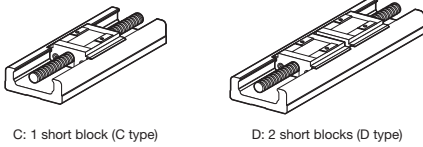

### ⑥ Motor Mounting Method

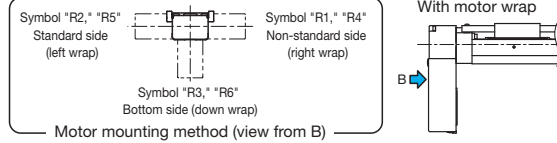

## Selection Information

### Basic Specifications

LM Guide	Basic dynamic load rating C (N)		17,600		
	Basic static load rating C <sub>0</sub> (N)		23,100		
	Radial clearance (mm)	Normal grade/High accuracy grade (H)	-0.006 to +0.003		
		Precision grade (P)	-0.016 to -0.006		
	Geometric moment of inertia	I <sub>x</sub> <sup>1</sup> (mm <sup>4</sup> )	8.4×10 <sup>4</sup>		
I <sub>y</sub> <sup>2</sup> (mm <sup>4</sup> )		8.9×10 <sup>5</sup>			
Mass (kg/m)		9			
Ball screw	Ball screw lead (mm)		5	10	20
	Basic dynamic load rating Ca (N)	Normal grade/High accuracy grade (H)	5,500	3,140	3,040
		Precision grade (P)	4,100	2,940	3,430
	Basic static load rating C <sub>0a</sub> (N)	Normal grade/High accuracy grade (H)	13,900	6,760	7,150
		Precision grade (P)	6,960	3,720	5,290
	Screw shaft diameter (mm)		Ø16	Ø15	
	Thread minor diameter (mm)		Ø13.4	Ø12.4	
	Ball center-to-center diameter (mm)		Ø16.75	Ø15.75	
Permissible rotational speed <sup>3</sup> (min <sup>-1</sup> )	Normal grade/High accuracy grade (H)	2,980	3,170		
	Precision grade (P)	4,170	4,440		
Bearing unit (fixed side)	Axial direction	Basic dynamic load rating Ca (N)	6,660		
		Static permissible load P <sub>0a</sub> (N)	3,240		
Permissible input torque (N·m)	Direct coupling	2.8	5.3		
	Motor wrap	2.8	4.5		
Static permissible moment <sup>4,5</sup> (N·m)		M <sub>A</sub> : 130 (994), M <sub>C</sub> : 130 (994), M <sub>B</sub> : 463 (925)			
Service life <sup>6</sup> (km)		5,000	10,000		
Standard grease/Grease nipple used		THK AFB-LF Grease/A-M6F			

- <sup>1</sup> I<sub>x</sub> is the geometric moment of inertia about the X axis.  
<sup>2</sup> I<sub>y</sub> is the geometric moment of inertia about the Y axis.  
<sup>3</sup> The permissible rotational speed may decrease as the stroke becomes longer.  
<sup>4</sup> The value in parentheses is with 2 short blocks (D type) attached.  
<sup>5</sup> See p. 172 for the values if "1" or "2" is selected for item ⑦ in the Model Number Coding.  
<sup>6</sup> Calculated under the following conditions.  
 Stroke: 530 mm (C type), 460 mm (D type) / Speed: 240 mm/s (for 5 mm lead), 500 mm/s (for 10 mm lead), 1,000 mm/s (for 20 mm lead) / Load mass: Maximum load capacity (p. 9) / Acceleration/deceleration: As when set to maximum load capacity (p. 9) / Center of gravity: Center of the table's upper surface.
- Notes: 1. LM Guide load rating is the load rating per short block.  
 2. KR45H05, KR45H10 precision grade (P-grade) ball screws have integrated spacer balls with a 1:1 ratio.  
 3. KR45H20 precision grade (P-grade) ball screws have integrated spacer balls with a 2:1 ratio.

### Geometric Moment of Inertia

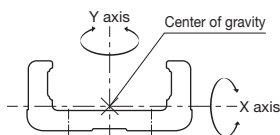

### Static Permissible Moment

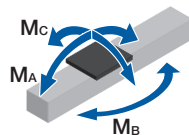

### Accuracy

Accuracy grade	Item	Stroke <sup>7</sup>						
		230	330	430	530	630	730	830
Normal grade (no symbol)	Positioning repeatability (mm)	±0.01						
	Positioning accuracy (mm)	Not specified						
	Running parallelism (vertical direction) (mm)	Not specified						
	Backlash (mm)	0.02						
	Starting torque (N·cm)	10						
High accuracy grade (H)	Positioning repeatability (mm)	±0.005						
	Positioning accuracy (mm)	0.06		0.12		0.15		
	Running parallelism (vertical direction) (mm)	0.03		0.04				
	Backlash (mm)	0.01						
	Starting torque (N·cm)	10						
Precision grade (P)	Positioning repeatability (mm)	±0.003			±0.005			
	Positioning accuracy (mm)	0.025		0.03		0.035		
	Running parallelism (vertical direction) (mm)	0.015		0.02		0.025		
	Backlash (mm)	0.003						
	Starting torque (N·cm)	15		17				

- <sup>7</sup> Stroke with 1 short block (C type).  
 Notes: 4. Precision evaluation in accordance with THK standards.  
 5. Measured using a motor for inspection. With motor wrap specifications, measurements are not made in the completed motor wrap state.  
 6. The starting torque represents the value when containing THK AFB-LF Grease.  
 7. The starting torque may exceed standards if using vacuum grease, clean room grease, or other high-viscosity greases, so care should be taken when selecting a motor.  
 8. Contact THK for accuracy higher than the standard stroke.

### Motor Selection Information

Stroke <sup>1</sup> (mm)	Outer rail length (mm)	LM Guide				Ball screw		Motor mounting part	
		Moving part mass (kg)			Sliding resistance value <sup>2</sup> (N)	Lead (mm)	Shaft length (mm)	Direct coupling	Motor wrap
		Block mass	Sub-table mass	Total mass				Shaft end diameter (mm)	Timing pulley (sum of two) Inertial moment x 10 <sup>-4</sup> (kg·m <sup>2</sup> )
230 to 830	340 to 940	C type: 0.6 D type: 1.2	C type: 0.2 D type: 0.4	C type: 0.8 D type: 1.6	4.6	5, 10, 20	403 to 1,003	Ø10h7	0.86

<sup>1</sup> Stroke with 1 short block (C type).

<sup>2</sup> Value with 1 short block (C type). This value is the sum of the rolling resistance value and seal resistance value.

Note: Refer to p. 99 for applicable couplings.

### Permissible Overhang Length<sup>3</sup>

Horizontal

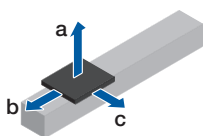

Wall-Mounted

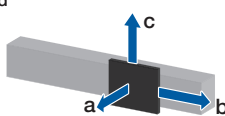

Vertical

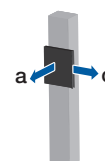

Estimated motor capacity	Ball screw lead	Load mass	a	b	c	
200 W	(mm)	(kg)	(mm)	(mm)	(mm)	
Direct coupling	C type	5	9.5	170	60	60
			19	70	30	30
			38.5	10	0	10
		10	9.5	170	60	60
			19	70	30	30
			38.5	10	10	10
	D type	5	3.5	540	170	170
			7.5	230	80	80
			15	90	40	40
		10	16.5	360	120	70
			33	160	60	30
			66.5	60	20	10
Motor wrap	C type	5	11.5	800	360	220
			23	250	80	50
			47	0	10	10
		10	11.5	140	50	50
			23.5	50	20	20
			47	0	10	10
	D type	5	9.5	170	60	60
			19	70	30	30
			38.5	10	10	10
		10	3.5	540	170	170
			7.5	230	80	80
			15	90	40	40

Estimated motor capacity	Ball screw lead	Load mass	a	b	c	
200 W	(mm)	(kg)	(mm)	(mm)	(mm)	
Direct coupling	C type	5	9	20	100	330
			18.5	0	0	160
			37.5	0	0	80
		10	6	50	130	500
			12.5	0	50	240
			25.5	0	20	110
	D type	5	3	150	210	800
			6.5	40	90	460
			13	0	40	190
		10	13	40	210	700
			26.5	0	100	340
			53	0	50	170
Motor wrap	C type	5	5.5	170	490	800
			11.5	60	230	790
			23	0	110	390
		10	9	20	100	330
			18.5	0	0	160
			37.5	0	0	80
	D type	5	6	50	130	500
			12.5	0	50	240
			25.5	0	20	110
		10	3	150	210	800
			6.5	40	90	460
			13	0	40	190

Estimated motor capacity	Ball screw lead	Load mass	a	c	
200 W	(mm)	(kg)	(mm)	(mm)	
Direct coupling	C type	5	3	120	230
			6	40	110
			12	0	50
		10	2	190	340
			4.5	60	150
			9.5	10	50
	D type	5	1	430	460
			2.5	150	210
			5.5	40	80
		10	9	130	230
			18	40	110
			36.5	0	50
Motor wrap	C type	5	4.5	300	460
			9	130	230
			18	40	110
		10	2	720	800
			4	340	520
			8	150	260
	D type	5	3	120	230
			6	40	110
			12	0	50
		10	2	190	340
			4.5	60	150
			9.5	10	50

Estimated motor capacity	Ball screw lead	Load mass	a	b	c	
400 W	(mm)	(kg)	(mm)	(mm)	(mm)	
Direct coupling	C type	5	17	140	50	50
			34.5	50	20	20
			69.5	0	0	10
		10	9.5	170	60	60
			19	70	30	30
			38.5	10	10	10
	D type	5	3.5	540	170	170
			7.5	230	80	80
			15	90	40	40
		10	24.5	360	120	70
			49	160	60	30
			98.5	60	20	10
Motor wrap	C type	5	17	140	50	50
			34.5	50	20	20
			69.5	0	0	10
		10	9.5	170	60	60
			19	70	30	30
			38.5	10	10	10
	D type	5	3.5	540	170	170
			7.5	230	80	80
			15	90	40	40
		10	24.5	360	120	70
			49	160	60	30
			98.5	60	20	10

Estimated motor capacity	Ball screw lead	Load mass	a	b	c	
400 W	(mm)	(kg)	(mm)	(mm)	(mm)	
Direct coupling	C type	5	11	50	130	500
			22.5	0	50	240
			45.5	0	20	110
		10	6	50	130	500
			12.5	0	50	240
			25.5	0	20	110
	D type	5	3	150	210	800
			6.5	40	90	460
			13	0	40	190
		10	13	40	210	700
			26.5	0	100	340
			53	0	50	170
Motor wrap	C type	5	9.5	80	280	800
			19.5	10	140	460
			39	0	70	230
		10	11	50	130	500
			22.5	0	50	240
			45.5	0	20	110
	D type	5	6	50	130	500
			12.5	0	50	240
			25.5	0	20	110
		10	3	150	210	800
			6.5	40	90	460
			13	0	40	190

Estimated motor capacity	Ball screw lead	Load mass	a	c	
400 W	(mm)	(kg)	(mm)	(mm)	
Direct coupling	C type	5	3	190	340
			6.5	60	150
			13.5	10	50
		10	2	190	340
			4.5	60	150
			9.5	10	50
	D type	5	1.5	270	350
			3.5	90	160
			7	30	60
		10	10	210	350
			20.5	90	170
			41	20	80
Motor wrap	C type	5	6	210	350
			12	90	170
			24	20	80
		10	4.5	300	460
			9	130	230
			18	40	110
	D type	5	3	190	340
			6.5	60	150
			13.5	10	50
		10	2	190	340
			4.5	60	150
			9.5	10	50

<sup>3</sup> This is the value with the service life of the LM Guide limited to 5,000 km (for 5 mm lead) or 10,000 km (for 10 mm or 20 mm lead). The calculation conditions are as follows.  
Stroke: 530 mm (C type), 460 mm (D type) / Acceleration/deceleration: 0.3 G / Speed: 240 mm/s (for 5 mm lead), 500 mm/s (for 10 mm lead), 1,000 mm/s (for 20 mm lead) / Overhang direction: Loaded only in a single direction. Dimensions a, b, and c are from the center of the table's upper surface.

With Cover  
Direct Motor Coupling

Dimensions

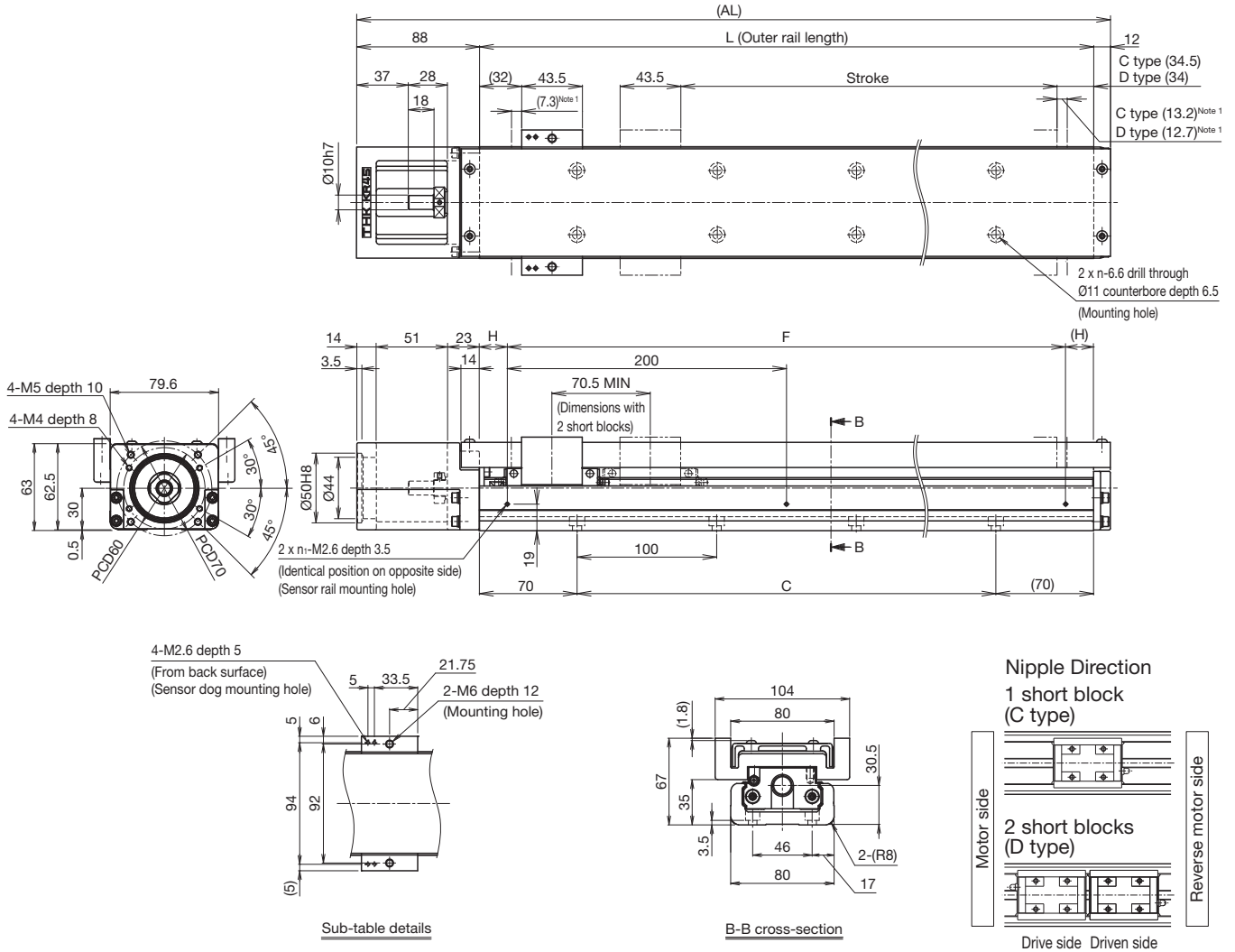

<sup>1</sup> Dimensions from the mechanical stopper to the stroke start position.

Stroke (mm) (Stroke between mechanical stoppers)	C type	230 (250.5)	330 (350.5)	430 (450.5)	530 (550.5)	630 (650.5)	730 (750.5)	830 (850.5)	
	D type <sup>2</sup>	160 (180)	260 (280)	360 (380)	460 (480)	560 (580)	660 (680)	760 (780)	
Maximum speed <sup>3</sup> (mm/s)	Ball screw lead: 5 mm	240						200	200
	Precision grade	340						260	200
		520						490	380
	Ball screw lead: 10 mm	740				640		490	380
Ball screw lead: 20 mm	Normal grade/high accuracy grade	1,050						980	770
	Precision grade	1,480				1,280		980	770
Dimensions (mm)	AL	440	540	640	740	840	940	1,040	
	L	340	440	540	640	740	840	940	
	C	200	300	400	500	600	700	800	
	F	200	400	400	600	600	800	800	
	H	70	20	70	20	70	20	70	
No. of mounting holes	n	3	4	5	6	7	8	9	
	n <sub>1</sub>	2	3	3	4	4	5	5	
Mass <sup>4</sup> (kg)		5.8	7	8.1	9.3	10.4	11.6	12.7	

<sup>2</sup> The value with 2 short blocks (D type) attached.

<sup>3</sup> The maximum speed is restricted by the actuator's permissible speed.

<sup>4</sup> The mass with 2 short blocks (D type) has 0.8 kg added.

Without Cover  
Direct Motor Coupling

Dimensions

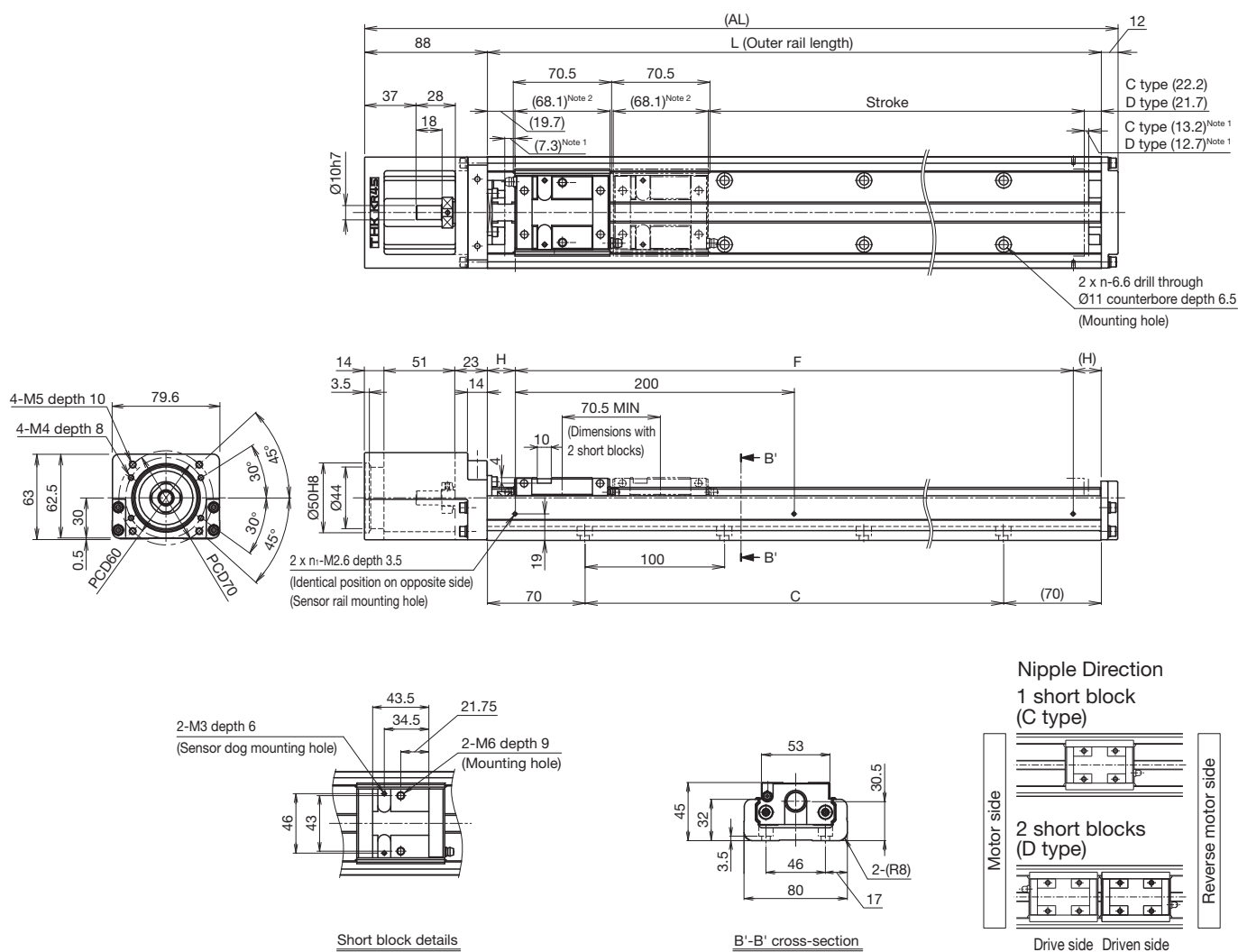

<sup>1</sup> Dimensions from the mechanical stopper to the stroke start position.  
<sup>2</sup> Shows the short block length when calculating the enabled stroke range.  
138.6 mm (2 blocks total) for KR45H with 2 short blocks (D type).

Stroke (mm) (Stroke between mechanical stoppers)	C type	230 (250.5)	330 (350.5)	430 (450.5)	530 (550.5)	630 (650.5)	730 (750.5)	830 (850.5)
	D type <sup>3</sup>	160 (180)	260 (280)	360 (380)	460 (480)	560 (580)	660 (680)	760 (780)
Maximum speed <sup>4</sup> (mm/s)	Ball screw lead: 5 mm	Normal grade/high accuracy grade		240				200
		Precision grade		340				200
	Ball screw lead: 10 mm	Normal grade/high accuracy grade		520				490
		Precision grade		740		640		380
Ball screw lead: 20 mm	Normal grade/high accuracy grade			1,050				980
	Precision grade			1,480		1,280		770
Dimensions (mm)	AL	440	540	640	740	840	940	1,040
	L	340	440	540	640	740	840	940
	C	200	300	400	500	600	700	800
	F	200	400	400	600	600	800	800
	H	70	20	70	20	70	20	70
No. of mounting holes	n	3	4	5	6	7	8	9
	n <sub>1</sub>	2	3	3	4	4	5	5
Mass <sup>5</sup> (kg)		5	6.1	7.1	8.2	9.3	10.3	11.4

<sup>3</sup> The value with 2 short blocks (D type) attached.  
<sup>4</sup> The maximum speed is restricted by the actuator's permissible speed.  
<sup>5</sup> The mass with 2 short blocks (D type) has 0.6 kg added.

With Cover  
Motor Wrap

Dimensions

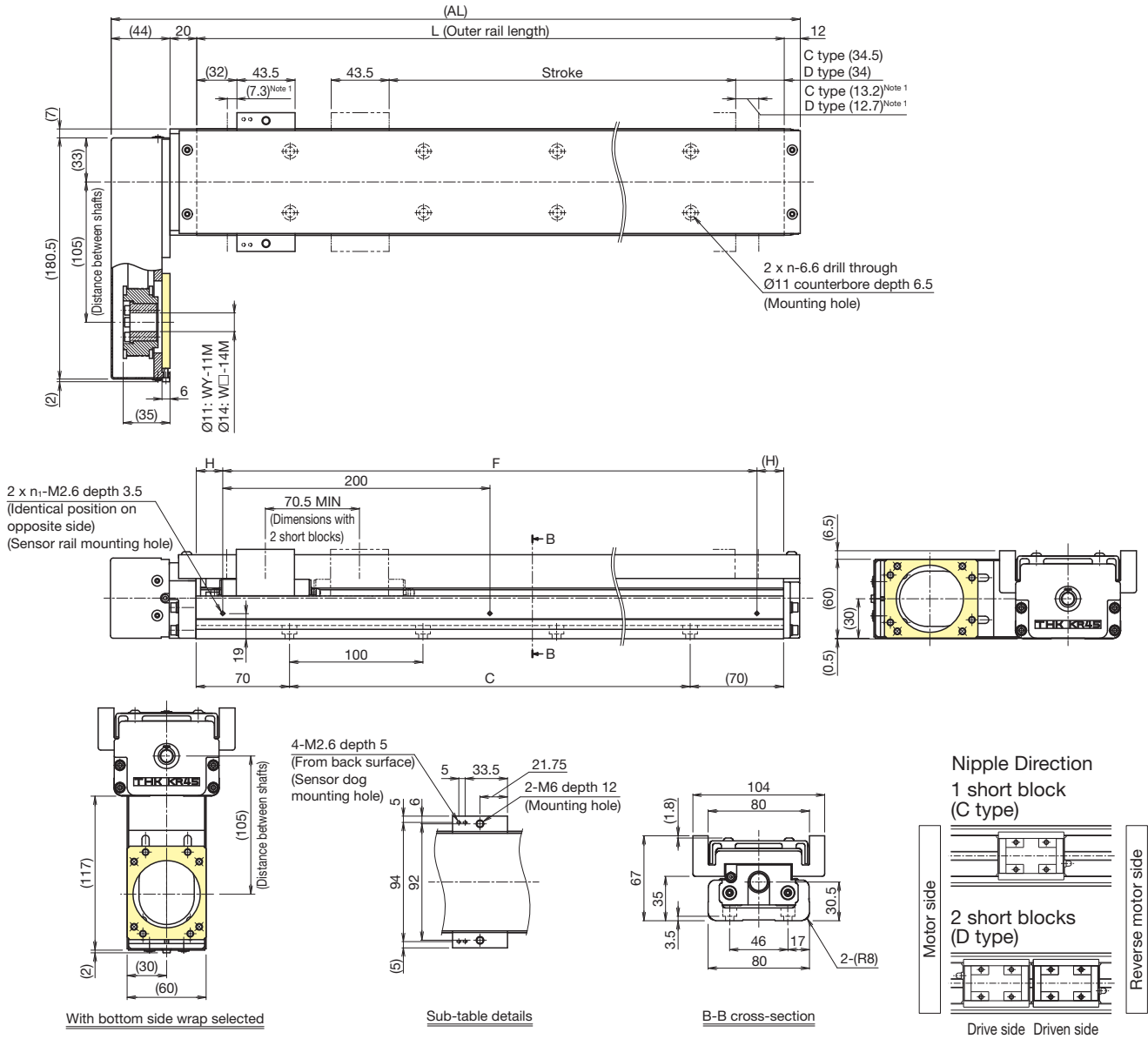

<sup>1</sup> Dimensions from the mechanical stopper to the stroke start position.

Stroke (mm) (Stroke between mechanical stoppers)	C type	230 (250.5)	330 (350.5)	430 (450.5)	530 (550.5)	630 (650.5)	730 (750.5)	830 (850.5)	
	D type <sup>2</sup>	160 (180)	260 (280)	360 (380)	460 (480)	560 (580)	660 (680)	760 (780)	
Maximum speed <sup>3</sup> (mm/s)	Ball screw lead: 5 mm	Normal grade/high accuracy grade						240	200
		Precision grade						340	260
	Ball screw lead: 10 mm	Normal grade/high accuracy grade						520	490
		Precision grade						740	380
Ball screw lead: 20 mm	Normal grade/high accuracy grade	1,050				640	490	380	
	Precision grade	1,480				1,280	980	770	
Dimensions (mm)	AL	416	516	616	716	816	916	1,016	
	L	340	440	540	640	740	840	940	
	C	200	300	400	500	600	700	800	
	F	200	400	400	600	600	800	800	
	H	70	20	70	20	70	20	70	
No. of mounting holes	n	3	4	5	6	7	8	9	
	n <sub>1</sub>	2	3	3	4	4	5	5	
Mass <sup>4</sup> (kg)		6.8	7.9	9.1	10.2	11.4	12.5	13.6	

<sup>2</sup> The value with 2 short blocks (D type) attached.  
<sup>3</sup> The maximum speed is restricted by the actuator's permissible speed.  
<sup>4</sup> The mass with 2 short blocks (D type) has 0.8 kg added.

Without Cover  
Motor Wrap

Dimensions

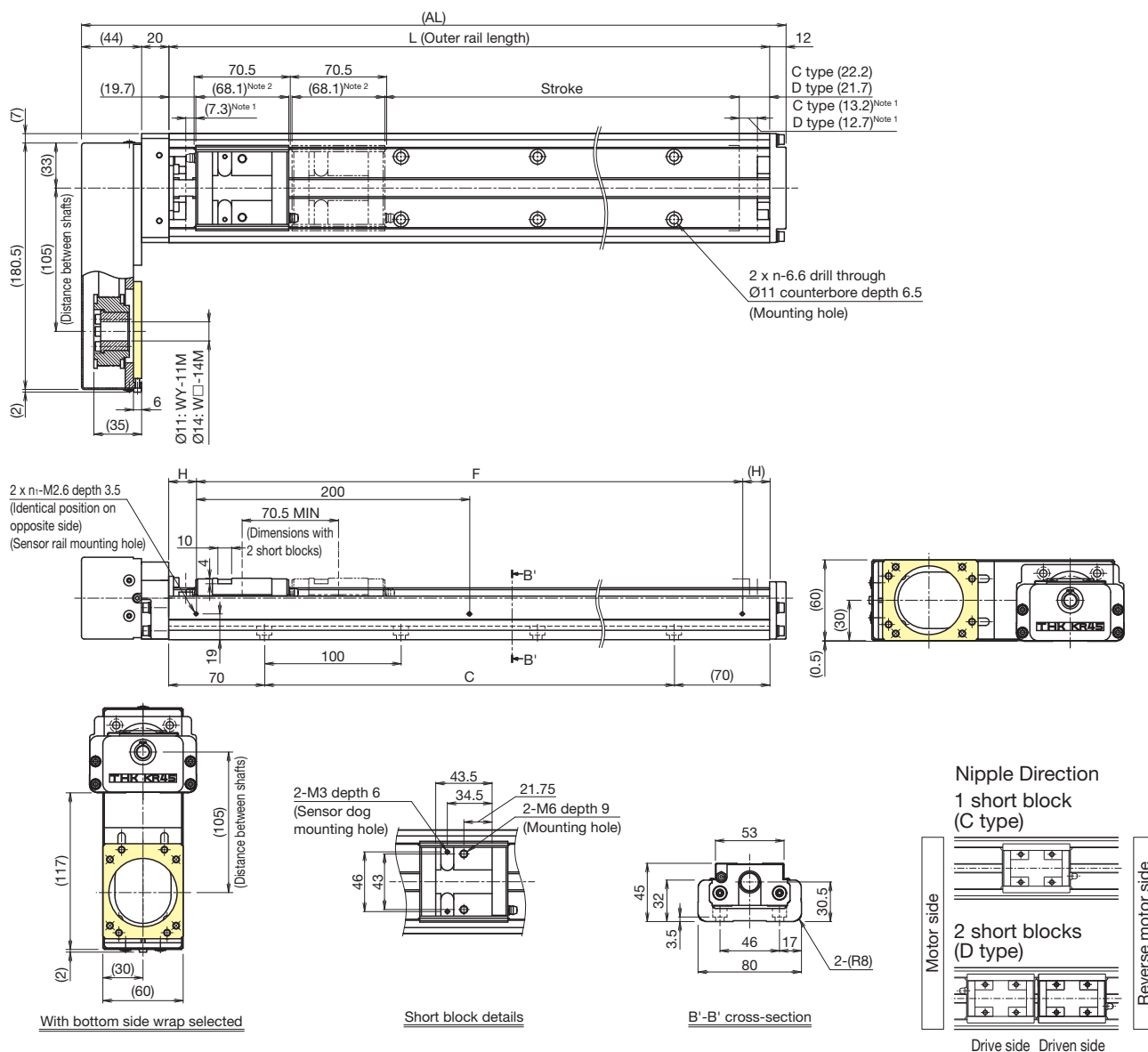

<sup>1</sup> Dimensions from the mechanical stopper to the stroke start position.  
<sup>2</sup> Shows the short block length when calculating the enabled stroke range. 138.6 mm (2 blocks total) for KR45H with 2 short blocks (D type).

Stroke (mm) (Stroke between mechanical stoppers)	C type		230 (250.5)	330 (350.5)	430 (450.5)	530 (550.5)	630 (650.5)	730 (750.5)	830 (850.5)
	D type <sup>3</sup>		160 (180)	260 (280)	360 (380)	460 (480)	560 (580)	660 (680)	760 (780)
Maximum speed <sup>4</sup> (mm/s)	Ball screw lead: 5 mm	Normal grade/high accuracy grade	240						200
		Precision grade	340						260
	Ball screw lead: 10 mm	Normal grade/high accuracy grade	520						490
		Precision grade	740						490
Ball screw lead: 20 mm	Normal grade/high accuracy grade	1,050						980	
	Precision grade	1,480						980	
Dimensions (mm)	AL		416	516	616	716	816	916	1,016
	L		340	440	540	640	740	840	940
	C		200	300	400	500	600	700	800
	F		200	400	400	600	600	800	800
	H		70	20	70	20	70	20	70
No. of mounting holes	n		3	4	5	6	7	8	9
	n <sub>1</sub>		2	3	3	4	4	5	5
Mass <sup>5</sup> (kg)			6	7	8.1	9.1	10.2	11.3	12.3

<sup>3</sup> The value with 2 short blocks (D type) attached.  
<sup>4</sup> The maximum speed is restricted by the actuator's permissible speed.  
<sup>5</sup> The mass with 2 short blocks (D type) has 0.6 kg added.

# Options

## Sensors

Optional photo sensors and proximity sensors are available. Sensor-equipped models also feature a dedicated sensor rail and sensor dog.

Sensors, sensor rails, and sensor dogs can be mounted on both sides when the stroke is less than 70 mm.

Mounting example

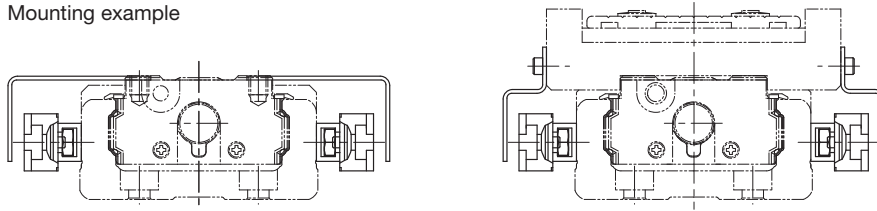

Symbol	Description	Model	Accessories
0	None	-	-
1	With sensor rail	-	Mounting screws, sensor rail (x1 or 2)
2	Photo sensor <sup>1</sup> (x3)	EE-SX671 (OMRON Corporation)	Mounting screws, nuts, sensor dog (x1 or 2), sensor rail (x1 or 2), mounting plates (x3), connectors (EE-1001 x3)
6	Photo sensor <sup>1</sup> (x3)	EE-SX674 (OMRON Corporation)	Mounting screws, nuts, sensor dog (x1 or 2), sensor rail (x1 or 2), mounting plates (x3), connectors (EE-1001 x3)
7	Proximity sensor N.O. contact <sup>2</sup> (x3)	APM-D3A1-001 (Azbil Corporation)	Mounting screws, nuts, sensor dog (x1 or 2), sensor rail (x1 or 2)
B	Proximity sensor N.C. contact <sup>3</sup> (x3)	APM-D3B1-003 (Azbil Corporation)	Mounting screws, nuts, sensor dog (x1 or 2), sensor rail (x1 or 2)
E	Proximity sensor N.O. contact <sup>2</sup> (x1) N.C. contact <sup>3</sup> (x2)	APM-D3A1-001 (Azbil Corporation) APM-D3B1-003 (Azbil Corporation)	Mounting screws, nuts, sensor dog (x1 or 2), sensor rail (x1 or 2)
H	Proximity sensor N.O. contact <sup>2</sup> (x3)	GX-F12A (Panasonic Industry Co., Ltd.)	Mounting screws, nuts, sensor dog (x1 or 2), sensor rail (x1 or 2)
L	Proximity sensor N.C. contact <sup>3</sup> (x3)	GX-F12B (Panasonic Industry Co., Ltd.)	Mounting screws, nuts, sensor dog (x1 or 2), sensor rail (x1 or 2)
J	Proximity sensor N.O. contact <sup>2</sup> (x1) N.C. contact <sup>3</sup> (x2)	GX-F12A (Panasonic Industry Co., Ltd.) GX-F12B (Panasonic Industry Co., Ltd.)	Mounting screws, nuts, sensor dog (x1 or 2), sensor rail (x1 or 2)
M	Proximity sensor N.O. contact <sup>2</sup> (x1) (PNP output) N.C. contact <sup>3</sup> (x2) (PNP output)	GX-F12A-P (Panasonic Industry Co., Ltd.) GX-F12B-P (Panasonic Industry Co., Ltd.)	Mounting screws, nuts, sensor dog (x1 or 2), sensor rail (x1 or 2)

<sup>1</sup> The photo sensors can be switched between ON when lit and ON when unlit.

<sup>2</sup> N.O. contact: Normally open contact point

<sup>3</sup> N.C. contact: Normally closed contact point

Notes: 1. If proximity sensors are close to one another, they may not function properly. If that happens, please prepare a type with a different frequency.

2. Mounting of sensors other than those in the table above is possible. Contact THK for details.

## Sensor Rail Mounting Dimensions

Mounting only a sensor rail is also possible.

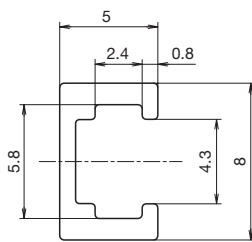

Sensor rail details

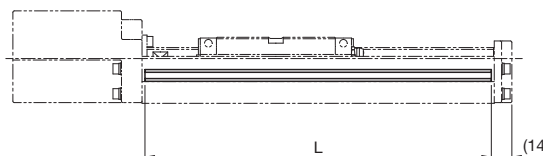

Stroke <sup>4</sup> (mm)	Outer rail length (mm)	L (mm)
200	340	336
300	440	436
400	540	536
500	640	636
600	740	736
700	840	836
800	940	936

<sup>4</sup> Stroke with 1 block (A type).

### Photo Sensor Mounting Dimensions

Connector: EE-1001 (OMRON Corporation) x3 included.  
To be mounted by the customer.

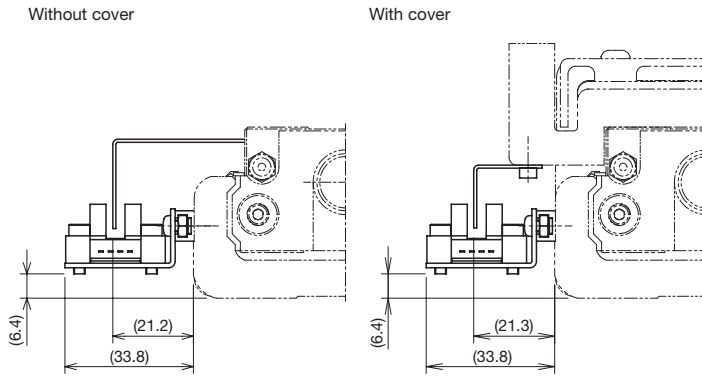

Symbol	Model	Manufacturer
2	EE-SX671	OMRON Corporation

Sensor dog width: 10 mm

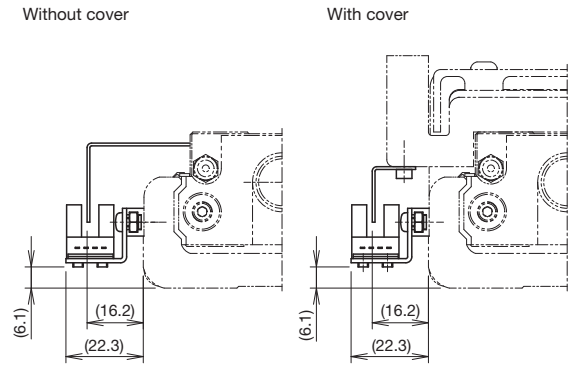

Symbol	Model	Manufacturer
6	EE-SX674	OMRON Corporation

Sensor dog width: 10 mm

### Proximity Sensor Mounting Dimensions

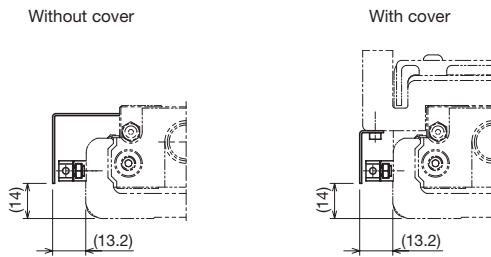

Symbol	Model	Manufacturer
7, B, E	APM-D3A1-001	Azbil Corporation
	APM-D3B1-003	

Sensor dog width: 10 mm

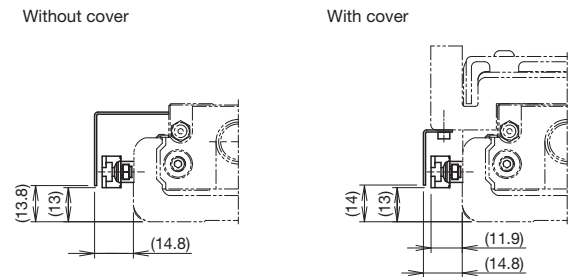

Symbol	Model	Manufacturer
H, L, J	GX-F12A	Panasonic Industry Co., Ltd.
	GX-F12B	
M	GX-F12A-P	
	GX-F12B-P	

Sensor dog width: 10 mm

# Options

## Intermediate Flange (Direct Coupling)

Several types of intermediate flanges for mounting motors are available.

When selecting "0" or "1" for Model Number Coding ⑥ With/without motor, specify an intermediate flange that matches the motor used.

Compatibility Table: Motors Used, Intermediate Flanges, and Couplings

Motor type	Manufacturer	Series	Motor model	Motor rated output (W)	Flange size	Housing A/ Intermediate flange	Compatible coupling models					
							MIKI PULLEY CO., LTD.	Nabeya Bi-tech Kaisha (NBK)				
AC servo motor	YASKAWA Electric Corporation	Σ-V	SGMJV-02	200	60×60	A0	SFC-030DA2-10B-14B	XGT2-27C-10-14				
			SGMAV-02									
			SGMJV-04	400								
			SGMAV-04									
			SGMJV-06	600								
		Σ-7	SGM7J-02	200	60×60	A0	SFC-030DA2-10B-14B	XGT2-27C-10-14				
			SGM7A-02									
			SGM7J-04	400								
			SGM7A-04									
			SGM7J-06	600								
		Σ-X	SGMXJ-02	200	60×60	A0	SFC-030DA2-10B-14B	XGT2-27C-10-14				
			SGMXA-02									
			SGMXJ-04	400								
			SGMXA-04									
			SGMXJ-06	600								
	SGMXA-06											
	Mitsubishi Electric Corporation	MELSERVO	J4	HG-KR23	200	60×60	A0	SFC-030DA2-10B-14B	XGT2-27C-10-14			
				HG-MR23								
				HG-KR43								
			HG-MR43	400								
			HK-KT23W									
		HK-KT43W	200									
		J5	HF-KN23	200	60×60	A0	SFC-030DA2-10B-14B	XGT2-27C-10-14				
			HF-KN43	400								
		TAMAGAWA SEIKI CO., LTD.	TBL-III	TS4607	200	60×60	A0	SFC-030DA2-10B-14B	XGT2-27C-10-14			
				TS4609	400							
	TSM3202		200									
	TSM3204		400									
	Panasonic Corporation	MINAS	A5	MSMD02	200	60×60	AY	SFC-030DA2-10B-11B	XGT2-30C-10-11			
				MSME02								
				MSMD04	400							
				MSME04								
		A6	MSMF02	200	60×60					AY	SFC-030DA2-10B-11B	XGT2-30C-10-11
			MHMF02									
			MSMF04	400								
			MHMF04									
	KEYENCE CORPORATION	SV	SV-M020	200	60×60	A0	SFC-030DA2-10B-14B	XGT2-27C-10-14				
			SV-M040	400								
		SV2	SV2-M020	200								
			SV2-M040	400								
	SANYO DENKI CO., LTD.	SANMOTION R	R2□A06020	200	60×60	A0	SFC-030DA2-10B-14B	XGT2-27C-10-14				
			R2AA06040	400								
OMRON Corporation	OMNUC G5	R88M-K20030	200	60×60	AY	SFC-030DA2-10B-11B	XGT2-30C-10-11					
		R88M-K40030	400									
	1S	R88M-1M20030	200									
		R88M-1M40030	400									

Motor type	Manufacturer	Series	Motor model	Flange size	Housing A/ Intermediate flange	Compatible coupling models			
						MIKI PULLEY CO., LTD.	Nabeya Bi-tech Kaisha (NBK)		
Stepper motor	ORIENTAL MOTOR CO., LTD.	α step	AZ6*, AR6*	60×60	AU	SFC-025DA2-10B-10B-L46	XGL2-25C-10-10		
			5-phase	CRK <sup>1</sup> (CRK569PM*)	60×60	AU	SFC-025DA2-8B-10B-L46 (SFC-025DA2-10B-10B-L46)	XGL2-25C-8-10 (XGL2-25C-10-10)	
		KEYENCE CORPORATION	2-phase	RK II	RKS56*	60×60	AU	SFC-025DA2-10B-10B-L46	XGL2-25C-10-10
				PKP <sup>1</sup>	PKP56* (PKP569FM*)	60×60	AU	SFC-025DA2-8B-10B-L46 (SFC-025DA2-10B-10B-L46)	XGL2-25C-8-10 (XGL2-25C-10-10)
	SANYO DENKI CO., LTD.	2-phase	QS-M60	QS-M60	60×60	AU	SFC-025DA2-8B-10B-L46	XGL2-25C-8-10	
			PB	PBDM60*, PBA**60*	60×60	AU	SFC-025DA2-10B-10B-L46	XGL2-25C-10-10	
		5-phase	FAM56*/FDM56*/ FA512M60/FB512M60	60×60	AU	SFC-025DA2-10B-10B-L46	XGL2-25C-10-10		
			2-phase	DB16H78*	60×60	AU	SFC-025DA2-8B-10B-L46	XGL2-25C-8-10	

<sup>1</sup> Items in parentheses have different motor shaft diameters and require a coupling to be specified.  
 Notes: 1. The table shows only a portion of the model numbers for motors. For details regarding model numbers, please see the catalog for each respective motor manufacturer.  
 2. If the maximum torque for motors exceeds the permissible input torque (A/B → p. 85, C/D → p. 91), please consider a safety measure to limit the torque.  
 3. When installing a motor other than the motor model numbers listed above, contact THK.

### Housing A

KR45H
A0

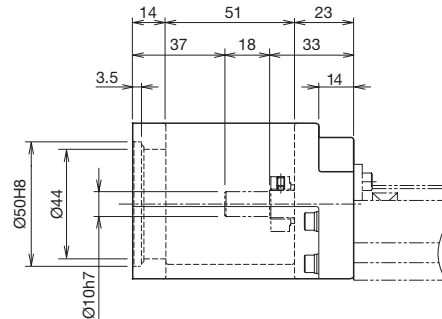
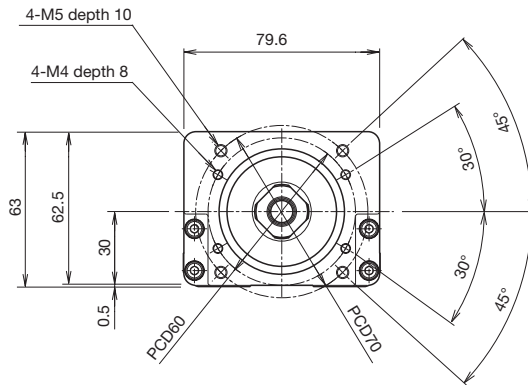

KR**	Actuator model
●◇	●: Housing A ◇: Intermediate flange

### Intermediate Flange

KR45H
AY

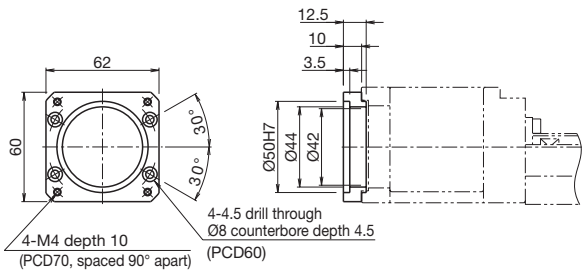

KR45H
AU

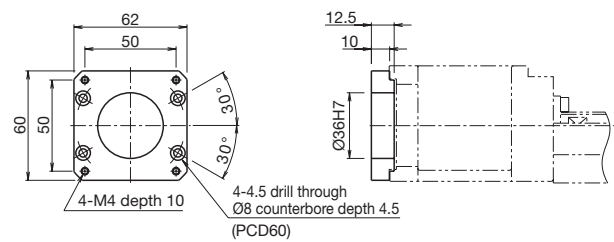

# Options

## Intermediate Flange (Motor Wrap)

Several types of intermediate flanges for mounting motors are available.

When selecting "R1," "R2," "R3," "R4," "R5," or "R6" for Model Number Coding ⑥ With/without motor, specify an intermediate flange that matches the motor used.

### Symbol Coding

Motor wrap symbol ①	Intermediate flange ②	Motor shaft diameter (mm) ③	Motor shaft securing method ④
W	V	14	M
W	Refer to the Compatibility Table: Motors Used and Motor Wrap Symbols below.	Specify a motor shaft diameter. (Refer to the Compatibility Table: Motors Used and Motor Wrap Symbols below.)	M: Friction tightening tool

### Motor Shaft Securing Method

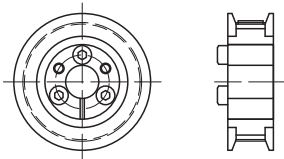

Friction tightening tool

Compatibility Table: Motors Used and Motor Wrap Symbols

Motor type	Manufacturer	Series	Motor model	Motor rated output (W)	Flange size	Housing A/Intermediate flange
AC servo motor	YASKAWA Electric Corporation	Σ-V	SGMJV-02	200	60×60	WV-14M
			SGMAV-02			
			SGMJV-04	400		
			SGMAV-04			
		SGMJV-06	600			
		Σ-7	SGM7J-02	200	60×60	
			SGM7A-02			
			SGM7J-04	400		
			SGM7A-04			
		SGM7J-06	600			
		Σ-X	SGMXJ-02	200	60×60	
			SGMXA-02			
	SGMXJ-04		400			
	SGMXA-04					
	SGMXJ-06	600				
	Mitsubishi Electric Corporation	MELSERVO	J4	HG-KR23	200	60×60
				HG-MR23		
			HG-KR43	400		
			HG-MR43			
		J5	HK-KT23W	200	60×60	
			HK-KT43W	400		
		JN	HF-KN23	200	60×60	
			HF-KN43	400		
	TAMAGAWA SEIKI CO., LTD.	TBL-iii	TS4607	200	60×60	
			TS4609	400		
		TBL-iv	TSM3202	200		60×60
			TSM3204	400		
	Panasonic Corporation	MINAS	A5	MSMD02	200	60×60
				MSME02		
			MSMD04	400		
			MSME04			
		A6	MSMF02	200	60×60	
MHMF02						
MSMF04			400			
MHMF04						
KEYENCE CORPORATION	SV	SV-M020	200	60×60		
		SV-M040	400			
	SV2	SV2-M020	200		60×60	
		SV2-M040	400			
SANYO DENKI CO., LTD.	SANMOTION R	R2□A06020	200	60×60		
		R2AA06040	400			
OMRON Corporation	OMNUC G5	R88M-K20030	200	60×60		
		R88M-K40030	400			
	1S	R88M-1M20030	200		60×60	
		R88M-1M40030	400			

Notes: 1. The table shows only a portion of the model numbers for motors. For details regarding model numbers, please see the catalog for each respective motor manufacturer.  
 2. If the maximum torque for motors exceeds the permissible input torque (A/B → p. 85, C/D → p. 91), please consider a safety measure to limit the torque.  
 3. When installing a motor other than the motor model numbers listed above, contact THK.

Motor Wrap Housing A

KR45H
60

KR**	Actuator model
●◇	●: Housing A ◇: Intermediate flange

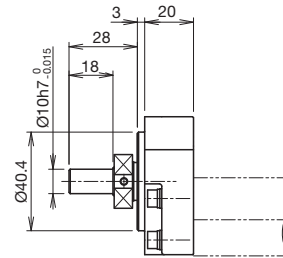
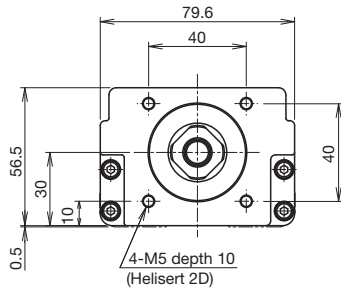

Motor Wrap Specification (Intermediate Flange)

KR45H
WV

Thickness: 6 mm

KR45H
WY

Thickness: 6 mm

KR**	Actuator model
W□	□: Intermediate flange

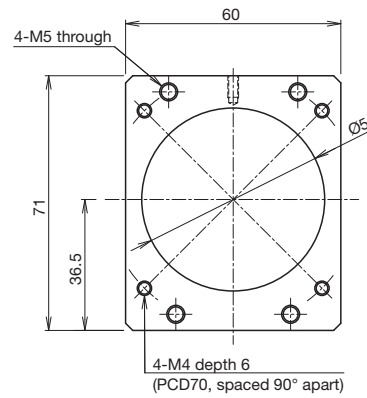
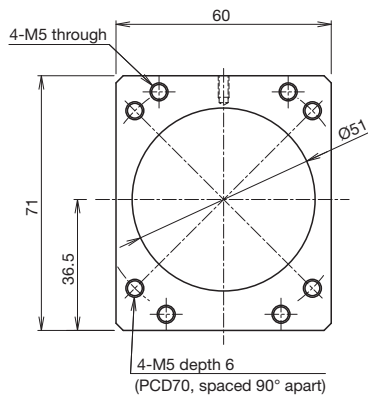

# KR46 A/B

Direct motor coupling

Motor wrap

Width 86 mm

Height 46 mm

Max. stroke 790 mm

## Model Number Coding

Model	Ball screw lead	Block type	QZ specification	Stroke	Accuracy grade	With/without motor	Cover	Sensors	Housing A/ Intermediate flange
①	②	③	④	⑤	⑥	⑦	⑧	⑨	⑩
KR46	10	A	QZA	0175	P	0	1	2	A0
<b>KR46</b>	<b>05: 5 mm</b> <b>10: 10 mm</b> <b>20: 20 mm</b>	<b>A: x1</b> <b>B: x2</b>	<b>No symbol: Without QZ</b> <b>QZ</b> <b>QZA</b> <b>QZB</b> <b>QZAD</b>	<b>0080: 80 mm</b> to <b>0790: 790 mm</b>	<b>No symbol: Normal grade</b> <b>H: High accuracy grade</b> <b>P: Precision grade</b>	<b>With direct coupling</b> <b>0: Direct coupling (without motor)</b> <b>1: Direct coupling (THK will purchase and mount the motor you specify.)</b> <b>With motor wrap</b> <b>R1: Non-standard side wrap (without motor)</b> <b>R2: Standard side wrap (without motor)</b> <b>R3: Bottom side wrap (without motor)</b> <b>R4: Non-standard side wrap (THK will purchase and mount the motor you specify.)</b> <b>R5: Standard side wrap (THK will purchase and mount the motor you specify.)</b> <b>R6: Bottom side wrap (THK will purchase and mount the motor you specify.)</b>	<b>0: Without cover</b> <b>1: With cover</b> <b>2: With bellows</b>	<b>0</b> <b>1</b> <b>2</b> <b>6</b> <b>7</b> <b>B</b> <b>E</b> <b>H</b> <b>L</b> <b>J</b> <b>M</b>	<b>With direct coupling</b> <b>A0</b> <b>10</b> <b>30</b> <b>40</b> <b>60</b> <b>With motor wrap</b> <b>WV - 14M</b> <b>WY - 11M</b> <b>WY - 14M</b> <b>With direct coupling → p. 121</b> <b>With motor wrap → p. 123</b>
<p>When selecting ⑧ Cover, specify the stroke with bellows. → p. 165 to p. 166</p> <p>When selecting ⑨ Sensors, specify the stroke with bellows. → p. 125 to p. 130</p> <p>When selecting "0": A coupling is not provided. Indicate when placing an order if a coupling is required.</p> <p>When selecting "1," "R4," "R5," or "R6": The specified motor will be installed. Indicate the motor cable direction separately. Select ⑩ Intermediate flange to match the specified motor.</p> <p>Sensor details → p. 119</p>									

### ③ Block Type

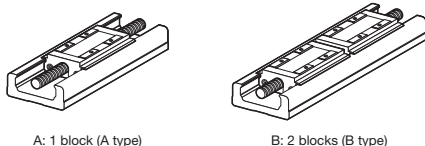

### ⑦ Motor Mounting Method

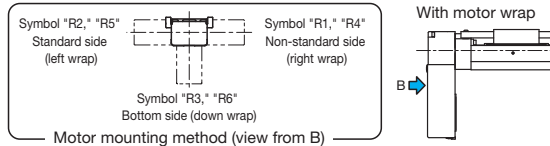

## Selection Information

### Basic Specifications

LM Guide	Basic dynamic load rating C (N)		35,200		
	Basic static load rating C <sub>0</sub> (N)		51,600		
	Radial clearance (mm)	Normal grade/High accuracy grade (H)	-0.006 to +0.003		
		Precision grade (P)	-0.016 to -0.006		
	Geometric moment of inertia	I <sub>x</sub> <sup>1</sup> (mm <sup>4</sup> )	2.4×10 <sup>5</sup>		
I <sub>y</sub> <sup>2</sup> (mm <sup>4</sup> )		1.5×10 <sup>5</sup>			
Mass (kg/m)		12.6			
Ball screw	Ball screw lead (mm)		5	10	20
	Basic dynamic load rating Ca (N)	Normal grade/High accuracy grade (H)	5,500	3,140	3,040
		Precision grade (P)	4,100	2,940	3,430
	Basic static load rating C <sub>0a</sub> (N)	Normal grade/High accuracy grade (H)	13,900	6,760	7,150
		Precision grade (P)	6,960	3,720	5,290
	Screw shaft diameter (mm)		Ø16	Ø15	
	Thread minor diameter (mm)		Ø13.4	Ø12.4	
	Ball center-to-center diameter (mm)		Ø16.75	Ø15.75	
Permissible rotational speed <sup>3</sup> (min <sup>-1</sup> )	Normal grade/High accuracy grade (H)	2,980	3,170		
	Precision grade (P)	4,170	4,440		
Bearing unit (fixed side)	Axial direction	Basic dynamic load rating Ca (N)	6,660		
		Static permissible load P <sub>0a</sub> (N)	3,240		
Permissible input torque (N·m)		Direct coupling	2.5	2.5	
		Motor wrap	2.8	4.5	
Static permissible moment <sup>4,5</sup> (N·m)		M <sub>A</sub> : 547 (2,940), M <sub>C</sub> : 547 (2,940), M <sub>B</sub> : 1,400 (2,800)			
Service life <sup>6</sup> (km)		5,000	10,000		
Standard grease/Grease nipple used		THK AFB-LF Grease/A-M6F			

- <sup>1</sup> I<sub>x</sub> is the geometric moment of inertia about the X axis.
  - <sup>2</sup> I<sub>y</sub> is the geometric moment of inertia about the Y axis.
  - <sup>3</sup> The permissible rotational speed may decrease as the stroke becomes longer.
  - <sup>4</sup> The value in parentheses is with 2 blocks (B type) attached.
  - <sup>5</sup> See p. 172 for the values if "1" or "2" is selected for item ⑧ in the Model Number Coding.
  - <sup>6</sup> Calculated under the following conditions:  
Stroke: 490 mm (A type), 380 mm (B type) / Speed: 240 mm/s (for 5 mm lead), 500 mm/s (for 10 mm lead), 1,000 mm/s (for 20 mm lead) / Load mass: Maximum load capacity (p. 9) / Acceleration/deceleration: As when set to maximum load capacity (p. 9) / Center of gravity: Center of the table's upper surface.
- Notes: 1. LM Guide load rating is the load rating per block.  
2. KR4610 precision grade (P-grade) ball screws have integrated spacer balls with a 1:1 ratio.  
3. KR4620 precision grade (P-grade) ball screws have integrated spacer balls with a 2:1 ratio.

### Geometric Moment of Inertia

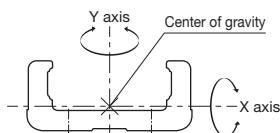

### Static Permissible Moment

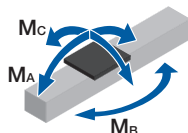

### Accuracy

Accuracy grade	Item	Stroke <sup>7</sup>						
		190	290	390	490	590	690	790
Normal grade (no symbol)	Positioning repeatability (mm)	±0.01						
	Positioning accuracy (mm)	Not specified						
	Running parallelism (vertical direction) (mm)	Not specified						
	Backlash (mm)	0.02						
	Starting torque (N·cm)	10						
High accuracy grade (H)	Positioning repeatability (mm)	±0.005						
	Positioning accuracy (mm)	0.05		0.12		0.15		
	Running parallelism (vertical direction) (mm)	0.03		0.04		0.05		
	Backlash (mm)	0.01						
	Starting torque (N·cm)	10						
Precision grade (P)	Positioning repeatability (mm)	±0.003			±0.005			
	Positioning accuracy (mm)	0.025		0.03		0.035		
	Running parallelism (vertical direction) (mm)	0.015		0.02		0.025		
	Backlash (mm)	0.003						
	Starting torque (N·cm)	15			17			

- <sup>7</sup> Stroke with 1 block (A type, without QZ).
- Notes: 4. Precision evaluation in accordance with THK standards.  
5. Measured using a motor for inspection. With motor wrap specifications, measurements are not made in the completed motor wrap state.  
6. The starting torque represents the value when containing THK AFB-LF Grease.  
7. The starting torque may exceed standards if using vacuum grease, clean room grease, or other high-viscosity greases, so care should be taken when selecting a motor.  
8. Contact THK for accuracy higher than the standard stroke.

## Motor Selection Information

Stroke <sup>1</sup> (mm)	Outer rail length (mm)	LM Guide				Ball screw		Motor mounting part	
		Moving part mass (kg)			Sliding resistance value <sup>2</sup> (N)	Lead (mm)	Shaft length (mm)	Direct coupling	Motor wrap
		Block mass	Sub-table mass	Total mass				Shaft end diameter (mm)	Timing pulley (sum of two) Inertial moment $\times 10^{-4}$ (kg·m <sup>2</sup> )
190 to 790	340 to 940	A type: 1 B type: 2	A type: 0.4 B type: 0.8	A type: 1.4 B type: 2.8	5	5, 10, 20	403 to 1,003	Ø8h7	0.86

<sup>1</sup> Stroke with 1 block (A type, without QZ).

<sup>2</sup> Value with 1 block (A type, without QZ). This value is the sum of the rolling resistance value and seal resistance value.

Note: Refer to p. 121 for applicable couplings.

# Permissible Overhang Length (200 W)<sup>1</sup>

Horizontal

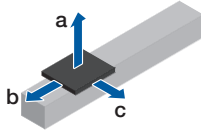

Wall-Mounted

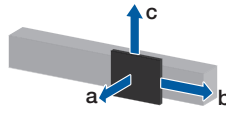

Vertical

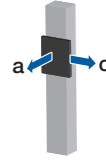

Estimated motor capacity 200 W		Ball screw lead (mm)	Load mass (kg)	a (mm)	b (mm)	c (mm)	
Direct coupling	A type	5	19	190	60	60	
			38.5	70	30	30	
			77	20	10	10	
		10	19	190	60	60	
			38.5	70	30	30	
			77	20	10	10	
	20	6	690	210	210		
		12.5	310	100	100		
		25.5	130	50	50		
		B type	5	27	740	230	230
				54	350	110	110
				108.5	150	50	50
10	27	860	230	90			
	54	860	110	40			
	108.5	150	50	20			
20	5	860	860	520			
	10.5	860	600	250			
	21	860	300	120			
Motor wrap	A type	5	19	190	60	60	
			38.5	70	30	30	
			77	20	10	10	
		10	17.5	210	70	70	
			35	80	30	30	
			70.5	20	10	10	
	20	3.5	860	370	370		
		7	590	180	180		
		14.5	260	90	90		
	B type	5	27	740	230	90	
			54	350	110	40	
			108.5	150	50	20	
10		20.5	860	300	120		
		41.5	860	150	60		
		83	210	70	30		
20	3	860	860	860			
	6.5	860	860	400			
	13	860	480	200			

Estimated motor capacity 200 W		Ball screw lead (mm)	Load mass (kg)	a (mm)	b (mm)	c (mm)
Direct coupling	A type	5	19	30	130	450
			38.5	0	60	220
			77	0	30	110
		10	15.5	40	160	550
			31	0	80	270
			62	0	40	130
	20	6	180	430	860	
		12.5	60	200	690	
		25.5	10	90	340	
	B type	5	27	60	260	860
			54	10	130	440
			108.5	0	60	220
10		27	60	260	860	
		54	10	130	440	
		108.5	0	60	220	
20	5	490	860	860		
	10.5	210	680	860		
	21	80	340	860		
Motor wrap	A type	5	19	30	130	450
			38.5	0	60	220
			77	0	30	110
		10	15.5	40	160	550
			31	0	80	270
			62	0	40	130
	20	3.5	340	740	860	
		7	150	370	860	
		14.5	50	170	590	
	B type	5	27	60	260	860
			54	10	130	440
			108.5	0	60	220
10		20.5	90	350	860	
		41.5	20	170	570	
		83	0	80	280	
20	3	840	860	860		
	6.5	360	860	860		
	13	160	550	860		

Estimated motor capacity 200 W		Ball screw lead (mm)	Load mass (kg)	a (mm)	c (mm)
Direct coupling	A type	5	10	60	200
			20	10	100
			40	0	50
		10	4.5	180	440
			9	70	220
			18	20	110
	20	2	470	860	
		4	210	500	
		8	90	250	
	B type	5	10	440	550
			20	200	270
			40	80	130
10		5.5	840	860	
		11	400	500	
		22.5	170	240	
20	2	860	860		
	4	860	860		
	8.5	530	650		
Motor wrap	A type	5	4.5	180	440
			9	70	220
			18	20	110
		10	4.5	180	440
			9	70	220
			18	20	110
	20	1.5	630	860	
		3.5	250	570	
		7	100	280	
	B type	5	4	860	860
			8	570	690
			16.5	250	330
10		4	860	860	
		8	570	690	
		16.5	250	330	
20	1.5	860	860		
	3	860	860		
	6	770	860		

<sup>1</sup> This is the value with the service life of the LM Guide limited to 5,000 km (for leads of 5 mm) or 10,000 km (for leads of 10 mm and 20 mm). The calculation conditions are as follows.  
 Stroke: 490 mm (A type), 380 mm (B type) / Acceleration/deceleration: 0.3 G / Speed: 240 mm/s (for 5 mm lead), 500 mm/s (for 10 mm lead), 1,000 mm/s (for 20 mm lead) / Overhang direction:  
 Loaded only in a single direction. Dimensions a, b, and c are from the center of the table's upper surface.

# Permissible Overhang Length (400 W)<sup>1</sup>

Horizontal

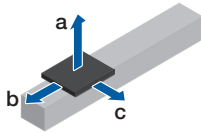

Wall-Mounted

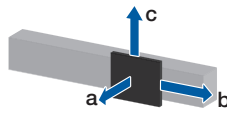

Vertical

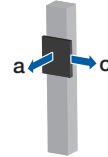

Estimated motor capacity 400 W		Ball screw lead (mm)	Load mass (kg)	a (mm)	b (mm)	c (mm)
Direct coupling	A type	5	24	140	50	50
			48	50	20	20
			96	0	10	10
		10	24	140	50	50
			48	50	20	20
			96	0	10	10
	20	12	320	100	100	
		24	140	50	50	
		48	50	20	20	
	B type	5	34	580	180	70
			68	270	90	30
			136	110	40	10
10		31.5	630	200	80	
		63.5	290	90	40	
		127.5	120	40	20	
20		11.5	860	540	220	
		23.5	850	260	110	
		47.5	400	130	50	

Estimated motor capacity 400 W		Ball screw lead (mm)	Load mass (kg)	a (mm)	b (mm)	c (mm)
Direct coupling	A type	5	19	30	130	860
			38.5	0	60	220
			77	0	30	110
		10	15.5	40	160	550
			31	0	80	270
			62	0	40	130
	20	9	110	280	860	
		18	30	140	480	
		36.5	0	60	230	
	B type	5	27	60	260	860
			54	10	130	440
			108.5	0	60	220
10		27	60	260	860	
		54	10	130	440	
		108.5	0	60	220	
20		11.5	190	620	860	
		23.5	70	300	860	
		47.5	10	150	500	

Estimated motor capacity 400 W		Ball screw lead (mm)	Load mass (kg)	a (mm)	c (mm)
Direct coupling	A type	5	10	60	200
			20	10	100
			40	0	50
		10	5.5	140	360
			11.5	50	170
			23	0	80
	20	4.5	180	440	
		9	70	220	
		18	20	110	
	B type	5	10	440	550
			20	200	270
			40	80	130
10		5.5	840	860	
		11	400	500	
		22.5	170	240	
20		4.5	860	860	
		9	500	610	
		18	230	300	

<sup>1</sup> This is the value with the service life of the LM Guide limited to 5,000 km (for leads of 5 mm) or 10,000 km (for leads of 10 mm and 20 mm). The calculation conditions are as follows.  
 Stroke: 490 mm (A type), 380 mm (B type) / Acceleration/deceleration: 0.3 G / Speed: 240 mm/s (for 5 mm lead), 500 mm/s (for 10 mm lead), 1,000 mm/s (for 20 mm lead) / Overhang direction:  
 Loaded only in a single direction. Dimensions a, b, and c are from the center of the table's upper surface.

With Cover  
Direct Motor Coupling

Dimensions

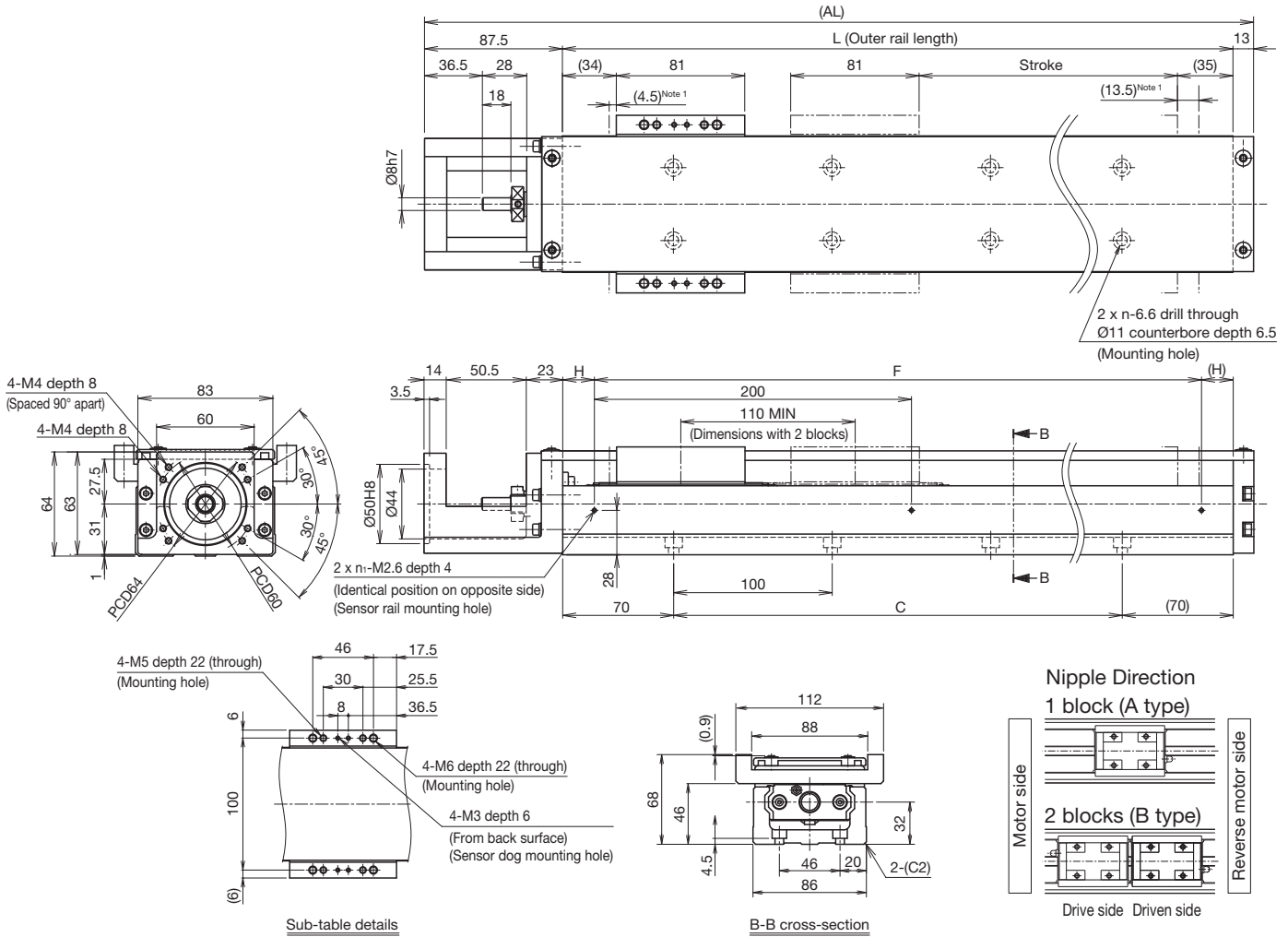

<sup>1</sup> Dimensions from the mechanical stopper to the stroke start position.

Stroke (mm) (Stroke between mechanical stoppers)	A type		190 (208)	290 (308)	390 (408)	490 (508)	590 (608)	690 (708)	790 (808)	
	B type <sup>2</sup>		80 (98)	180 (198)	280 (298)	380 (398)	480 (498)	580 (598)	680 (698)	
Maximum speed <sup>3</sup> (mm/s)	Ball screw lead: 5 mm	Normal grade/high accuracy grade	240						230	230
		Precision grade	340						300	430
	Ball screw lead: 10 mm	Normal grade/high accuracy grade	520						430	430
		Precision grade	740						550	850
Ball screw lead: 20 mm	Normal grade/high accuracy grade	1,050						850	850	
	Precision grade	1,480						1,440	1,090	850
Dimensions (mm)	AL		440.5	540.5	640.5	740.5	840.5	940.5	1,040.5	
	L		340	440	540	640	740	840	940	
	C		200	300	400	500	600	700	800	
	F		200	400	400	600	600	800	800	
	H		70	20	70	20	70	20	70	
No. of mounting holes	n		3	4	5	6	7	8	9	
	n <sub>1</sub>		2	3	3	4	4	5	5	
Mass <sup>4</sup> (kg)			7.5	9	10.5	12	13.5	14.9	16.4	

<sup>2</sup> The value with 2 blocks (B type, without QZ) attached.

<sup>3</sup> The maximum speed is restricted by the actuator's permissible speed.

<sup>4</sup> The mass with 2 blocks (B type) has 1.4 kg added.

Without Cover  
Direct Motor Coupling

**Dimensions**

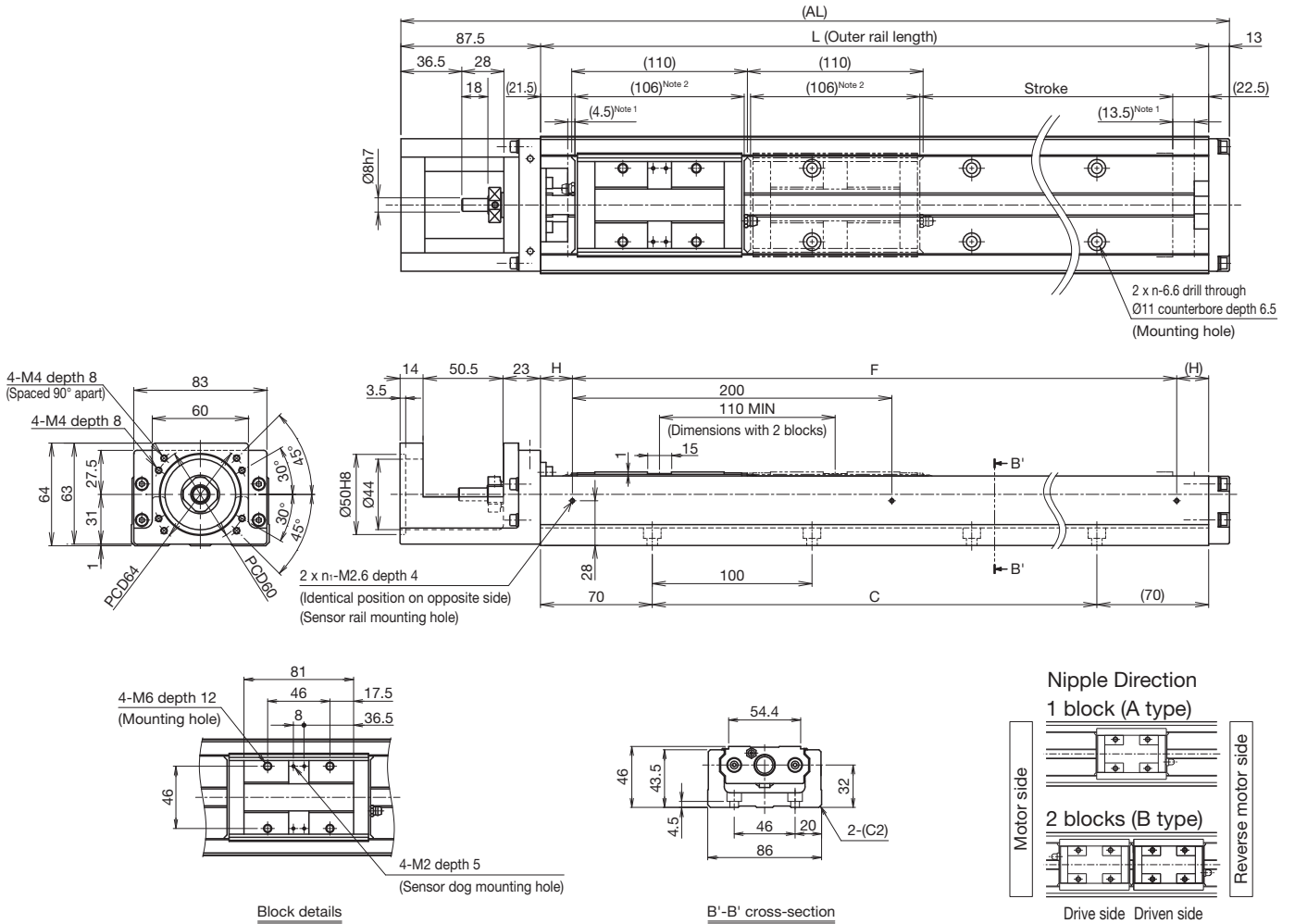

<sup>1</sup> Dimensions from the mechanical stopper to the stroke start position.  
<sup>2</sup> Shows the block length when calculating the enabled stroke range.  
 216 mm (2 blocks total) for KR46 with 2 blocks (B type, without QZ).

Stroke (mm) (Stroke between mechanical stoppers)	A type		190 (208)	290 (308)	390 (408)	490 (508)	590 (608)	690 (708)	790 (808)
	B type <sup>3</sup>		80 (98)	180 (198)	280 (298)	380 (398)	480 (498)	580 (598)	680 (698)
Maximum speed <sup>4</sup> (mm/s)	Ball screw lead: 5 mm	Normal grade/high accuracy grade	240						230
		Precision grade	340						300
	Ball screw lead: 10 mm	Normal grade/high accuracy grade	520						430
		Precision grade	740						550
Ball screw lead: 20 mm	Normal grade/high accuracy grade	1,050						850	
	Precision grade	1,480						1,440	1,090
Dimensions (mm)	AL		440.5	540.5	640.5	740.5	840.5	940.5	1,040.5
	L		340	440	540	640	740	840	940
	C		200	300	400	500	600	700	800
	F		200	400	400	600	600	800	800
	H		70	20	70	20	70	20	70
No. of mounting holes	n		3	4	5	6	7	8	9
	n <sub>i</sub>		2	3	3	4	4	5	5
Mass <sup>5</sup> (kg)			6.6	8	9.4	10.8	12.2	13.6	15

<sup>3</sup> The value with 2 blocks (B type, without QZ) attached.  
<sup>4</sup> The maximum speed is restricted by the actuator's permissible speed.  
<sup>5</sup> The mass with 2 blocks (B type) has 1 kg added.

With Cover  
Motor Wrap

Dimensions

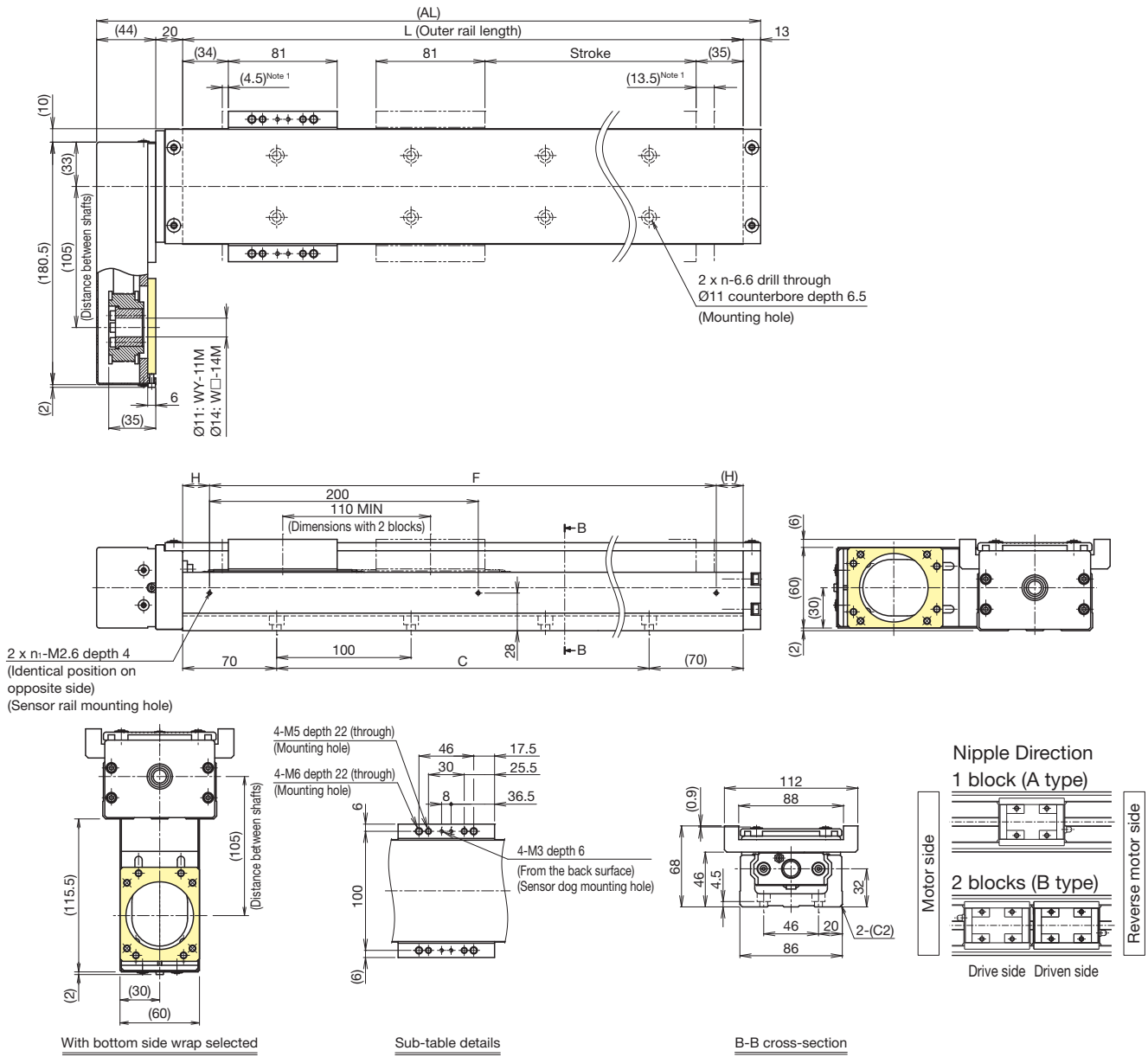

<sup>1</sup> Dimensions from the mechanical stopper to the stroke start position.

Stroke (mm) (Stroke between mechanical stoppers)	A type	190 (208)	290 (308)	390 (408)	490 (508)	590 (608)	690 (708)	790 (808)
	B type <sup>2</sup>	80 (98)	180 (198)	280 (298)	380 (398)	480 (498)	580 (598)	680 (698)
Maximum speed <sup>3</sup> (mm/s)	Ball screw lead: 5 mm	Normal grade/high accuracy grade		240		300		230
		Precision grade		340		300		230
	Ball screw lead: 10 mm	Normal grade/high accuracy grade		520		430		430
		Precision grade		740		550		430
Ball screw lead: 20 mm	Normal grade/high accuracy grade		1,050		850		850	
	Precision grade		1,480		1,440		1,090	850
Dimensions (mm)	AL	417	517	617	717	817	917	1,017
	L	340	440	540	640	740	840	940
	C	200	300	400	500	600	700	800
	F	200	400	400	600	600	800	800
	H	70	20	70	20	70	20	70
No. of mounting holes	n	3	4	5	6	7	8	9
	n <sub>1</sub>	2	3	3	4	4	5	5
Mass <sup>4</sup> (kg)		8.6	10	11.5	13	14.5	16	17.4

<sup>2</sup> The value with 2 blocks (B type, without QZ) attached.  
<sup>3</sup> The maximum speed is restricted by the actuator's permissible speed.  
<sup>4</sup> The mass with 2 blocks (B type) has 1.4 kg added.

Without Cover  
Motor Wrap

**Dimensions**

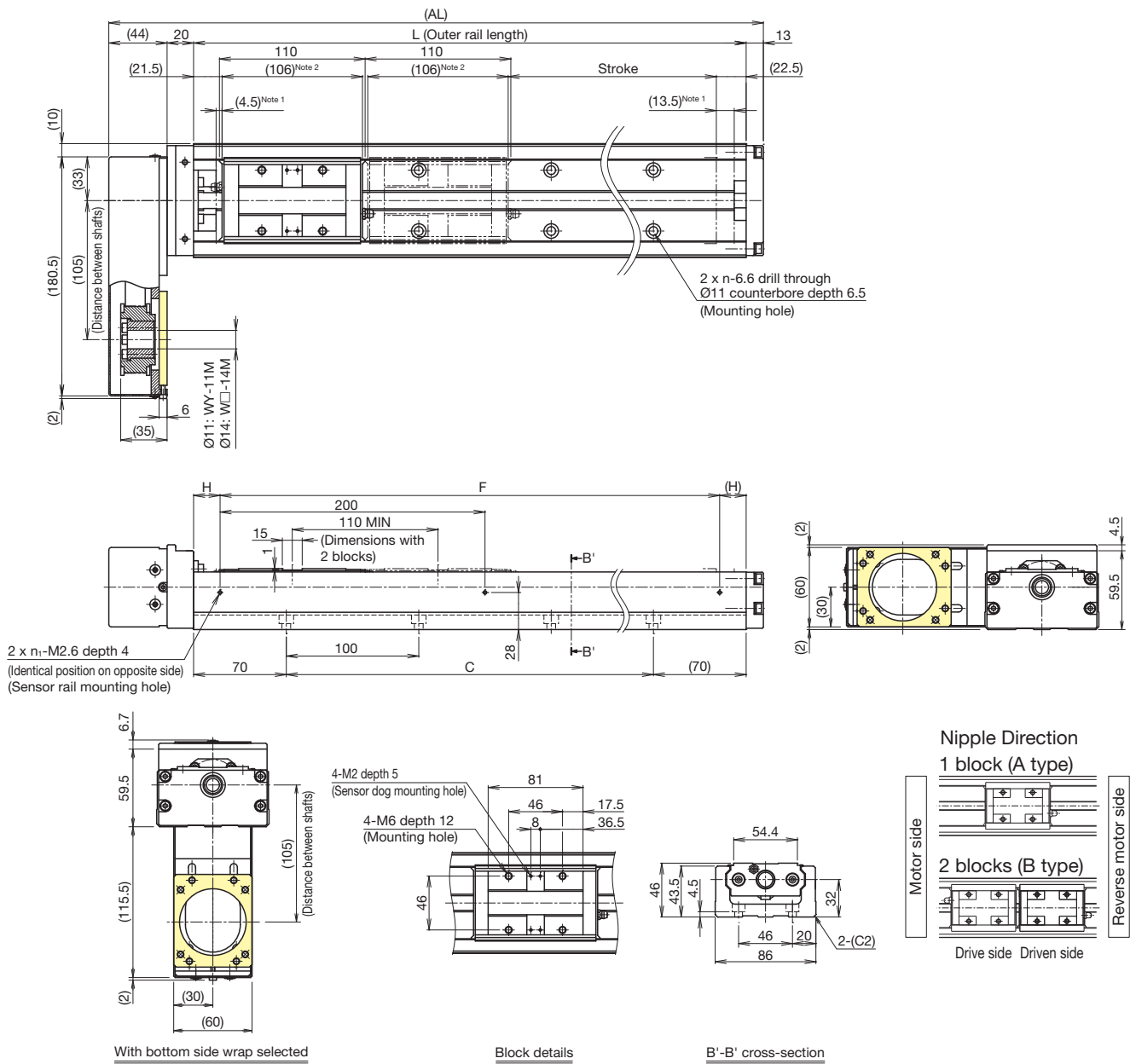

<sup>1</sup> Dimensions from the mechanical stopper to the stroke start position.  
<sup>2</sup> Shows the block length when calculating the enabled stroke range.  
 216 mm (2 blocks total) for KR46 with 2 blocks (B type, without QZ).

Stroke (mm) (Stroke between mechanical stoppers)	A type	190 (208)	290 (308)	390 (408)	490 (508)	590 (608)	690 (708)	790 (808)
	B type <sup>3</sup>	80 (98)	180 (198)	280 (298)	380 (398)	480 (498)	580 (598)	680 (698)
Maximum speed <sup>4</sup> (mm/s)	Ball screw lead: 5 mm	Normal grade/high accuracy grade		240				230
		Precision grade		340		300		230
	Ball screw lead: 10 mm	Normal grade/high accuracy grade		520				430
		Precision grade		740		550		430
Ball screw lead: 20 mm	Normal grade/high accuracy grade		1,050				850	
	Precision grade		1,480		1,440		1,090	850
Dimensions (mm)	AL	417	517	617	717	817	917	1,017
	L	340	440	540	640	740	840	940
	C	200	300	400	500	600	700	800
	F	200	400	400	600	600	800	800
	H	70	20	70	20	70	20	70
No. of mounting holes	n	3	4	5	6	7	8	9
	n <sub>1</sub>	2	3	3	4	4	5	5
Mass <sup>5</sup> (kg)		7.6	9	10.4	11.8	13.2	14.6	16

<sup>3</sup> The value with 2 blocks (B type, without QZ) attached.  
<sup>4</sup> The maximum speed is restricted by the actuator's permissible speed.  
<sup>5</sup> The mass with 2 blocks (B type) has 1 kg added.

# KR46 C/D

Direct motor coupling	Motor wrap	Width 86 mm	Height 46 mm	Max. stroke 820 mm
-----------------------	------------	-------------	--------------	--------------------

## Model Number Coding

Model	Ball screw lead	Block type	QZ specification	Stroke	Accuracy grade	With/without motor	Cover	Sensors	Housing A/ Intermediate flange
①	②	③	④	⑤	⑥	⑦	⑧	⑨	⑩
KR46	10	C	QZA	0205	P	0	1	2	A0
<b>KR46</b>	<b>05: 5 mm</b> <b>10: 10 mm</b> <b>20: 20 mm</b>	<b>C: x1</b> <b>D: x2</b>	<b>No symbol: Without QZ</b> <b>QZ</b> <b>QZA</b> <b>QZB</b> <b>QZAD</b>	<b>0150: 150 mm</b> to <b>0820: 820 mm</b>	<b>No symbol: Normal grade</b> <b>H: High accuracy grade</b> <b>P: Precision grade</b>	<b>With direct coupling</b> <b>0: Direct coupling (without motor)</b> <b>1: Direct coupling (THK will purchase and mount the motor you specify.)</b> <b>With motor wrap</b> <b>R1: Non-standard side wrap (without motor)</b> <b>R2: Standard side wrap (without motor)</b> <b>R3: Bottom side wrap (without motor)</b> <b>R4: Non-standard side wrap (THK will purchase and mount the motor you specify.)</b> <b>R5: Standard side wrap (THK will purchase and mount the motor you specify.)</b> <b>R6: Bottom side wrap (THK will purchase and mount the motor you specify.)</b>	<b>0: Without cover</b> <b>1: With cover</b> <b>2: With bellows</b>	<b>0</b> <b>1</b> <b>2</b> <b>6</b> <b>7</b> <b>B</b> <b>E</b> <b>H</b> <b>L</b> <b>J</b> <b>M</b>	<b>With direct coupling</b> <b>A0</b> <b>10</b> <b>30</b> <b>40</b> <b>60</b> <b>With motor wrap</b> <b>WV - 14M</b> <b>WY - 11M</b> <b>WY - 14M</b> <b>With direct coupling → p. 121</b> <b>With motor wrap → p. 123</b>
<p>Check the stroke for type with QZ when selecting anything other than "No symbol." → p. 125 to p. 130</p> <p>When selecting ⑧ Cover, specify the stroke with bellows. → p. 167 to p. 168</p> <p>When selecting "0": A coupling is not provided. Indicate when placing an order if a coupling is required.</p> <p>When selecting "1," "R4," "R5," or "R6": The specified motor will be installed. Indicate the motor cable direction separately. Select ⑩ Intermediate flange to match the specified motor.</p> <p>Sensor details → p. 119</p>									

### ③ Block Type

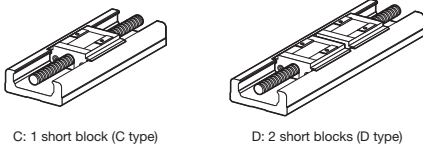

### ⑦ Motor Mounting Method

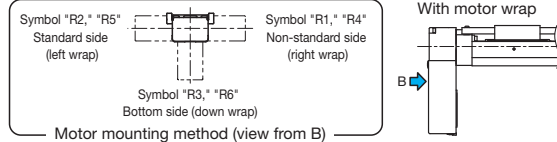

## Selection Information

### Basic Specifications

LM Guide	Basic dynamic load rating C (N)		22,500		
	Basic static load rating C <sub>0</sub> (N)		27,300		
	Radial clearance (mm)	Normal grade/High accuracy grade (H)	-0.006 to +0.003		
		Precision grade (P)	-0.016 to -0.006		
	Geometric moment of inertia	I <sub>x</sub> <sup>1</sup> (mm <sup>4</sup> )	2.4 × 10 <sup>5</sup>		
I <sub>y</sub> <sup>2</sup> (mm <sup>4</sup> )		1.5 × 10 <sup>5</sup>			
Mass (kg/m)		12.6			
Ball screw	Ball screw lead (mm)		5	10	20
	Basic dynamic load rating Ca (N)	Normal grade/High accuracy grade (H)	5,500	3,140	3,040
		Precision grade (P)	4,100	2,940	3,430
	Basic static load rating C <sub>0a</sub> (N)	Normal grade/High accuracy grade (H)	13,900	6,760	7,150
		Precision grade (P)	6,960	3,720	5,290
	Screw shaft diameter (mm)		Ø16	Ø15	
	Thread minor diameter (mm)		Ø13.4	Ø12.4	
Ball center-to-center diameter (mm)		Ø16.75	Ø15.75		
Permissible rotational speed <sup>3</sup> (min <sup>-1</sup> )	Normal grade/High accuracy grade (H)	2,980	3,170		
	Precision grade (P)	4,170	4,440		
Bearing unit (fixed side)	Axial direction	Basic dynamic load rating Ca (N)	6,660		
		Static permissible load P <sub>0a</sub> (N)	3,240		
Permissible input torque (N·m)		Direct coupling	2.8	2.5	
		Motor wrap	2.8	4.5	
Static permissible moment <sup>4,5</sup> (N·m)		M <sub>x</sub> : 149 (1,010), M <sub>y</sub> : 149 (1,010), M <sub>z</sub> : 700 (1,400)			
Service life <sup>6</sup> (km)		5,000	10,000		
Standard grease/Grease nipple used		THK AFB-LF Grease/A-M6F			

<sup>1</sup> I<sub>x</sub> is the geometric moment of inertia about the X axis.  
<sup>2</sup> I<sub>y</sub> is the geometric moment of inertia about the Y axis.  
<sup>3</sup> The permissible rotational speed may decrease as the stroke becomes longer.  
<sup>4</sup> The value in parentheses is with 2 short blocks (D type) attached.  
<sup>5</sup> See p. 172 for the values if "1" or "2" is selected for item ⑧ in the Model Number Coding.  
<sup>6</sup> Calculated under the following conditions.  
 Stroke: 520 mm (C type), 450 mm (D type) / Speed: 240 mm/s (for 5 mm lead), 500 mm/s (for 10 mm lead), 1,000 mm/s (for 20 mm lead) / Load mass: Maximum load capacity (p. 9) / Acceleration/deceleration: As when set to maximum load capacity (p. 9) / Center of gravity: Center of the table's upper surface.  
 Notes: 1. LM Guide load rating is the load rating per short block.  
 2. KR4610 precision grade (P-grade) ball screws have integrated spacer balls with a 1:1 ratio.  
 3. KR4620 precision grade (P-grade) ball screws have integrated spacer balls with a 2:1 ratio.

### Accuracy

Accuracy grade	Item	Stroke <sup>7</sup>							
		220	320	420	520	620	720	820	
		Normal grade (no symbol)	Positioning repeatability (mm)	±0.01					
			Positioning accuracy (mm)	Not specified					
			Running parallelism (vertical direction) (mm)	Not specified					
Backlash (mm)	0.02								
Starting torque (N·cm)		10							
Accuracy grade	Item	Stroke <sup>7</sup>							
		220	320	420	520	620	720	820	
		High accuracy grade (H)	Positioning repeatability (mm)	±0.005					
			Positioning accuracy (mm)	0.05	0.12	0.15			
			Running parallelism (vertical direction) (mm)	0.03	0.04	0.05			
Backlash (mm)	0.01								
Starting torque (N·cm)		10							
Accuracy grade	Item	Stroke <sup>7</sup>							
		220	320	420	520	620	720	820	
		Precision grade (P)	Positioning repeatability (mm)	±0.003					
			Positioning accuracy (mm)	0.025	0.03	0.035			
			Running parallelism (vertical direction) (mm)	0.015	0.02	0.025			
Backlash (mm)	0.003								
Starting torque (N·cm)		15	17						

<sup>7</sup> Stroke with 1 short block (C type, without QZ).  
 Notes: 4. Precision evaluation in accordance with THK standards.  
 5. Measured using a motor for inspection. With motor wrap specifications, measurements are not made in the completed motor wrap state.  
 6. The starting torque represents the value when containing THK AFB-LF Grease.  
 7. The starting torque may exceed standards if using vacuum grease, clean room grease, or other high-viscosity greases, so care should be taken when selecting a motor.  
 8. Contact THK for accuracy higher than the standard stroke.

### Geometric Moment of Inertia

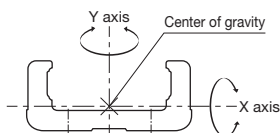

### Static Permissible Moment

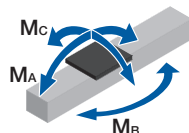

## Motor Selection Information

Stroke <sup>1</sup> (mm)	Outer rail length (mm)	LM Guide				Ball screw		Motor mounting part	
		Moving part mass (kg)			Sliding resistance value <sup>2</sup> (N)	Lead (mm)	Shaft length (mm)	Direct coupling	Motor wrap
		Block mass	Sub-table mass	Total mass				Shaft end diameter (mm)	Timing pulley (sum of two) Inertial moment $\times 10^{-4}$ (kg·m <sup>2</sup> )
220 to 820	340 to 940	C type: 0.6 D type: 1.2	C type: 0.2 D type: 0.4	C type: 0.8 D type: 1.6	4.5	5, 10, 20	405 to 1,005	Ø8h7	0.86

<sup>1</sup> Stroke with 1 short block (C type).

<sup>2</sup> Value with 1 short block (C type). This value is the sum of the rolling resistance value and seal resistance value.

Note: Refer to p. 121 for applicable couplings.

# Permissible Overhang Length (200 W)<sup>1</sup>

Horizontal

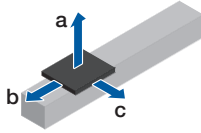

Wall-Mounted

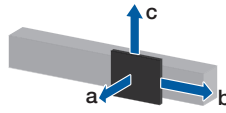

Vertical

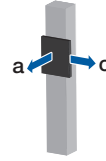

Estimated motor capacity 200 W	Ball screw lead (mm)	Load mass (kg)	a (mm)	b (mm)	c (mm)		
Direct coupling	C type	5	17	80	30	30	
			34.5	20	10	10	
			69.5	0	0	0	
		10	10.5	150	50	60	
			21.5	50	20	30	
			43.5	0	10	10	
	20	4	450	140	160		
		8.5	190	60	70		
		17	80	30	30		
		D type	5	24.5	240	80	50
				49	100	40	20
				98.5	30	20	10
	10	19.5	310	100	60		
			39.5	130	50	30	
			79	50	20	10	
		20	6	860	340	210	
				12	540	170	100
				24	250	80	50
Motor wrap	C type	5	17	80	30	30	
			34.5	20	10	10	
			69.5	0	0	0	
		10	10.5	150	50	60	
			21.5	50	20	30	
			43.5	0	10	10	
	20	4	450	140	160		
		8	210	70	80		
		16	80	30	40		
		D type	5	24.5	240	80	50
				49	100	40	20
				98.5	30	20	10
	10	19.5	310	100	60		
			39.5	130	50	30	
			79	50	20	10	
		20	4	860	520	320	
				8	830	260	160
				16.5	380	120	70

Estimated motor capacity 200 W	Ball screw lead (mm)	Load mass (kg)	a (mm)	b (mm)	c (mm)		
Direct coupling	C type	5	11	20	80	290	
			22.5	0	40	140	
			45.5	0	20	70	
		10	7.5	50	160	430	
			15	0	80	210	
			30	0	20	100	
	20	3.5	150	430	860		
		7.5	50	200	430		
		15	0	40	200		
		D type	5	19.5	30	140	490
				39.5	0	70	240
				79	0	30	120
	10	17	40	170	570		
			34	0	80	280	
			68	0	40	140	
		20	6	180	480	860	
				12	70	240	810
				24	10	120	400
Motor wrap	C type	5	11	20	80	290	
			22.5	0	40	140	
			45.5	0	20	70	
		10	7.5	50	160	430	
			15	0	80	210	
			30	0	20	100	
	20	3.5	150	740	860		
		7.5	50	370	430		
		15	0	170	200		
		D type	5	19.5	30	140	490
				39.5	0	70	240
				79	0	30	120
	10	17	40	170	570		
			34	0	80	280	
			68	0	40	140	
		20	4	290	720	860	
				8	120	360	860
				16.5	40	170	580

Estimated motor capacity 200 W	Ball screw lead (mm)	Load mass (kg)	a (mm)	c (mm)		
Direct coupling	C type	5	3	110	250	
			6.5	30	110	
			13.5	0	50	
		10	2.5	140	300	
			5.5	40	130	
			11	0	50	
	20	1	410	540		
		2.5	140	250		
		5.5	40	100		
		D type	5	10	120	220
				20.5	40	100
				41	0	50
	10	4.5	310	490		
			9	140	240	
			18	50	120	
		20	2	760	860	
				4	360	560
				8	160	280
Motor wrap	C type	5	3	110	250	
			6.5	30	110	
			13.5	0	50	
		10	2.5	140	300	
			5.5	40	130	
			11	0	50	
	20	1	410	540		
		2.5	140	250		
		5.5	40	100		
		D type	5	4	360	560
				8.5	150	260
				17.5	50	120
	10	4	360	560		
			8.5	150	260	
			17.5	50	120	
		20	1.5	860	860	
				3.5	420	640
				7.5	170	290

<sup>1</sup> This is the value with the service life of the LM Guide limited to 5,000 km (for leads of 5 mm) or 10,000 km (for leads of 10 mm and 20 mm). The calculation conditions are as follows.  
 Stroke: 520 mm (C type), 450 mm (D type) / Acceleration/deceleration: 0.3 G / Speed: 240 mm/s (for 5 mm lead), 500 mm/s (for 10 mm lead), 1,000 mm/s (for 20 mm lead) / Overhang direction:  
 Loaded only in a single direction. Dimensions a, b, and c are from the center of the table's upper surface.

# Permissible Overhang Length (400 W)<sup>1</sup>

Horizontal

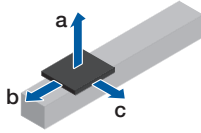

Wall-Mounted

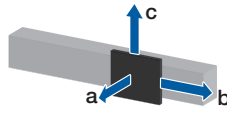

Vertical

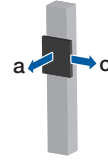

Estimated motor capacity 400 W		Ball screw lead (mm)	Load mass (kg)	a (mm)	b (mm)	c (mm)
Direct coupling	C type	5	17	80	30	30
			34.5	20	10	10
			69.5	0	0	0
		10	10.5	150	50	60
			21.5	50	20	30
			43.5	0	10	10
	20	4	450	140	160	
		8.5	190	60	70	
		17	80	30	30	
	D type	5	24.5	240	80	50
			49	100	40	20
			98.5	30	20	10
		10	24.5	240	80	50
			49	100	40	20
			98.5	30	20	10
	20	12.5	510	160	100	
		25.5	230	80	50	
		51.5	90	40	20	
Motor wrap	C type	5	17	80	30	30
			34.5	20	10	10
			69.5	0	0	0
		10	10.5	150	50	60
			21.5	50	20	30
			43.5	0	10	10
	20	4	450	140	160	
		8.5	190	60	70	
		17	80	30	30	
	D type	5	24.5	240	80	50
			49	100	40	20
			98.5	30	20	10
		10	24.5	240	80	50
			49	100	40	20
			98.5	30	20	10
	20	11.5	560	180	110	
		23	260	90	50	
		46.5	110	40	20	

Estimated motor capacity 400 W		Ball screw lead (mm)	Load mass (kg)	a (mm)	b (mm)	c (mm)
Direct coupling	C type	5	11	20	80	290
			22.5	0	40	140
			45.5	0	20	70
		10	7.5	50	130	430
			15	0	50	210
			30	0	20	100
	20	3.5	150	210	860	
		7.5	50	100	430	
		15	0	40	200	
	D type	5	19.5	30	140	490
			39.5	0	70	240
			79	0	30	120
		10	17	40	170	570
			34	0	80	280
			68	0	40	140
	20	12	70	240	810	
		24	10	120	400	
		48	0	60	200	
Motor wrap	C type	5	11	20	80	290
			22.5	0	40	140
			45.5	0	20	70
		10	7.5	50	160	430
			15	0	80	210
			30	0	20	100
	20	3.5	150	740	860	
		7.5	50	370	430	
		15	0	170	200	
	D type	5	19.5	30	140	490
			39.5	0	70	240
			79	0	30	120
		10	17	40	170	570
			34	0	80	280
			68	0	40	140
	20	11.5	70	250	840	
		23	20	120	420	
		46.5	0	60	200	

Estimated motor capacity 400 W		Ball screw lead (mm)	Load mass (kg)	a (mm)	c (mm)
Direct coupling	C type	5	3	110	250
			6.5	30	110
			13.5	0	50
		10	2.5	140	300
			5.5	40	130
			11	0	50
	20	2	190	360	
		4	70	160	
		8	20	60	
	D type	5	10	120	220
			20.5	40	100
			41	0	50
		10	5.5	250	400
			11.5	100	190
			23.5	30	90
	20	4.5	310	490	
		9	140	240	
		18	50	120	
Motor wrap	C type	5	3	110	250
			6.5	30	110
			13.5	0	50
		10	2.5	140	300
			5.5	40	130
			11	0	50
	20	2	190	360	
		4	70	160	
		8	20	60	
	D type	5	4	360	560
			8.5	150	260
			17.5	50	120
		10	4	360	560
			8.5	150	260
			17.5	50	120
	20	4	360	560	
		8.5	150	260	
		17.5	50	120	

<sup>1</sup> This is the value with the service life of the LM Guide limited to 5,000 km (for leads of 5 mm) or 10,000 km (for leads of 10 mm and 20 mm). The calculation conditions are as follows.  
 Stroke: 520 mm (C type), 450 mm (D type) / Acceleration/deceleration: 0.3 G / Speed: 240 mm/s (for 5 mm lead), 500 mm/s (for 10 mm lead), 1,000 mm/s (for 20 mm lead) / Overhang direction:  
 Loaded only in a single direction. Dimensions a, b, and c are from the center of the table's upper surface.

With Cover  
Direct Motor Coupling

Dimensions

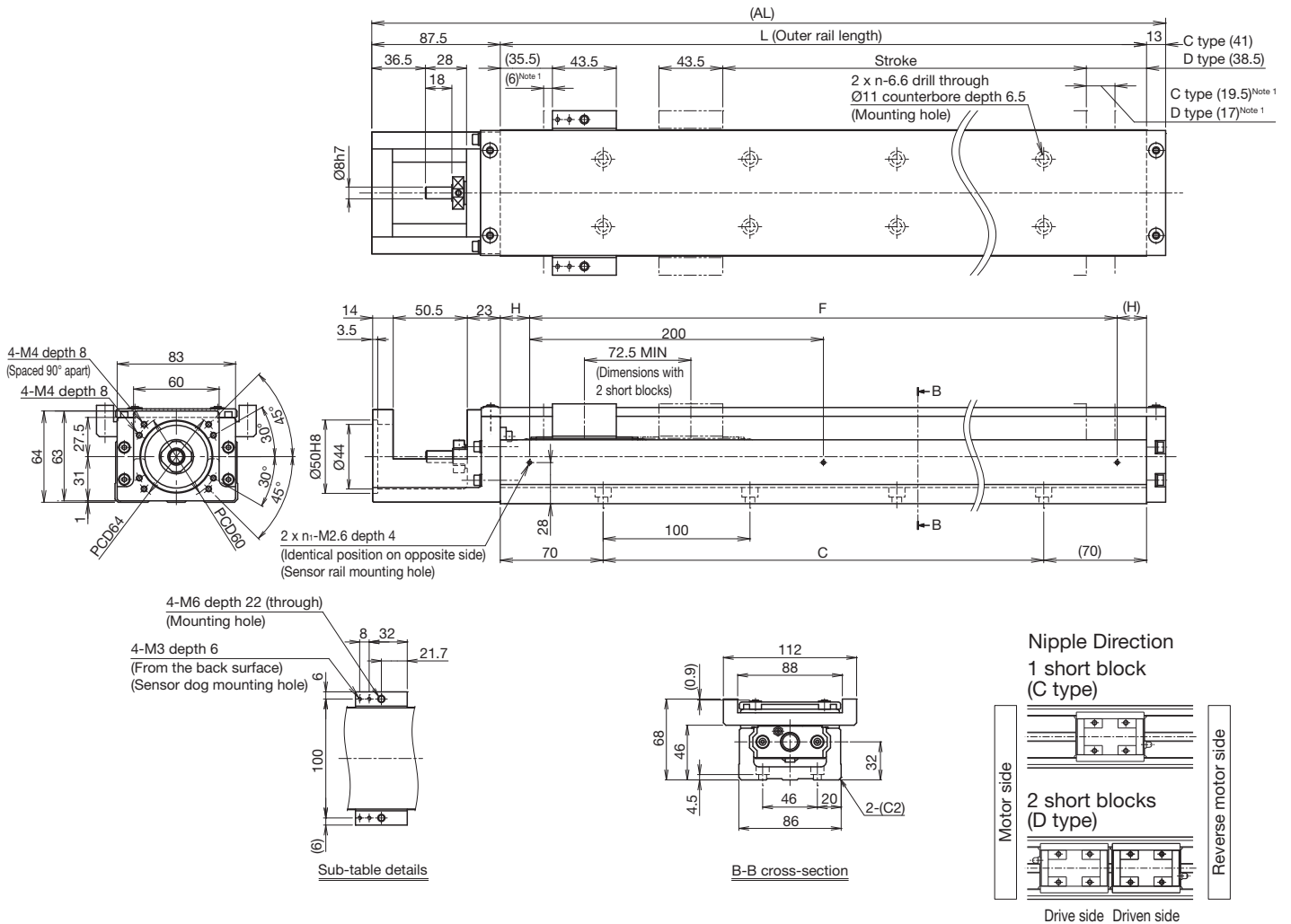

<sup>1</sup> Dimensions from the mechanical stopper to the stroke start position.

Stroke (mm) (Stroke between mechanical stoppers)	C type		220 (245.5)	320 (345.5)	420 (445.5)	520 (545.5)	620 (645.5)	720 (745.5)	820 (845.5)	
	D type <sup>2</sup>		150 (173)	250 (273)	350 (373)	450 (473)	550 (573)	650 (673)	750 (773)	
Maximum speed <sup>3</sup> (mm/s)	Ball screw lead: 5 mm	Normal grade/high accuracy grade	240							210
		Precision grade	340						260	210
	Ball screw lead: 10 mm	Normal grade/high accuracy grade	520						490	390
		Precision grade	740						650	490
Ball screw lead: 20 mm	Normal grade/high accuracy grade	1,050						990	780	
	Precision grade	1,480						1,300	990	780
Dimensions (mm)	AL		440.5	540.5	640.5	740.5	840.5	940.5	1,040.5	
	L		340	440	540	640	740	840	940	
	C		200	300	400	500	600	700	800	
	F		200	400	400	600	600	800	800	
	H		70	20	70	20	70	20	70	
No. of mounting holes	n		3	4	5	6	7	8	9	
	n <sub>1</sub>		2	3	3	4	4	5	5	
Mass <sup>4</sup> (kg)			6.9	8.4	9.9	11.4	12.9	14.3	15.8	

<sup>2</sup> The value with 2 short blocks (D type, without QZ) attached.

<sup>3</sup> The maximum speed is restricted by the actuator's permissible speed.

<sup>4</sup> The mass with 2 short blocks (D type) has 0.8 kg added.

Without Cover  
Direct Motor Coupling

**Dimensions**

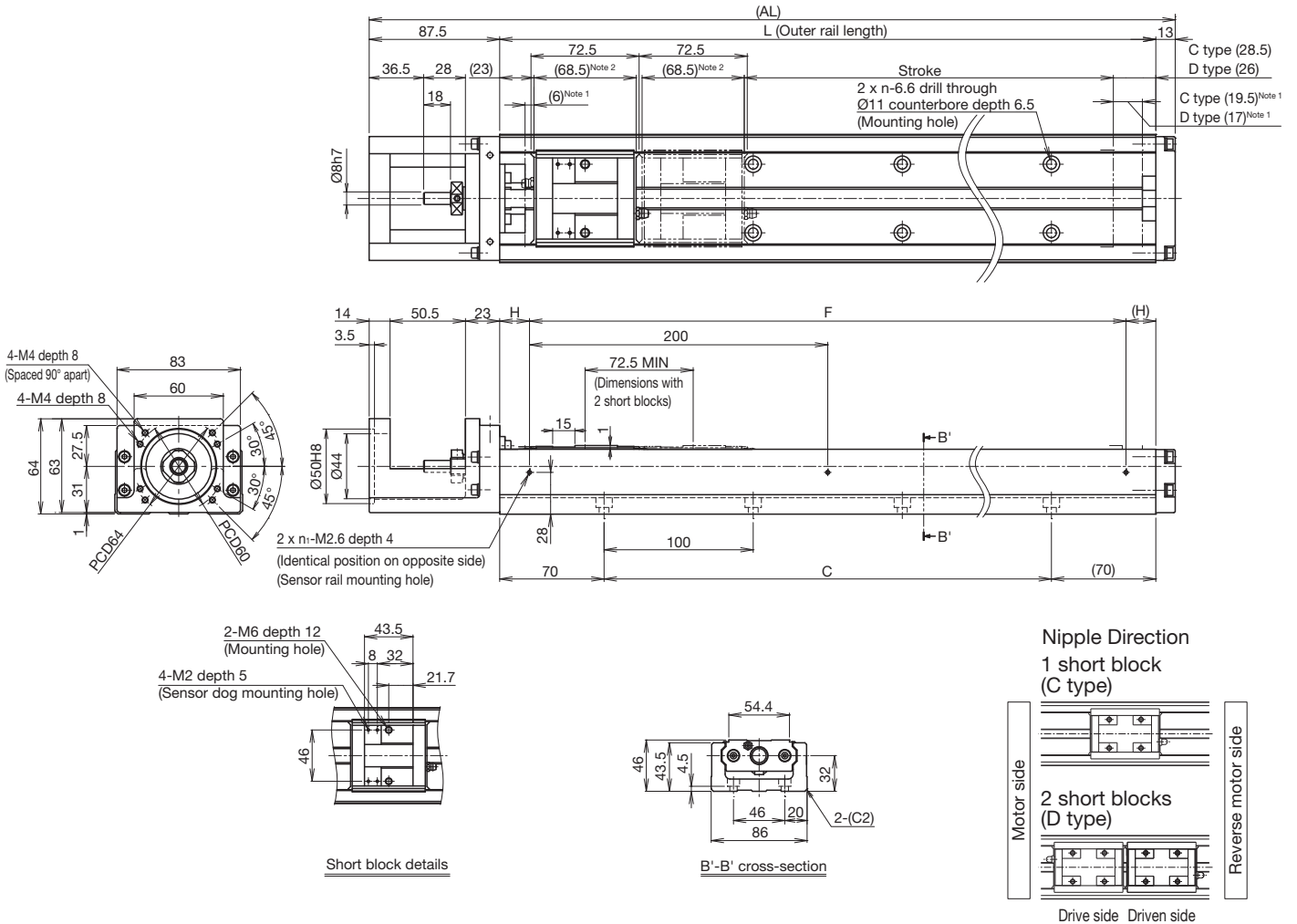

<sup>1</sup> Dimensions from the mechanical stopper to the stroke start position.  
<sup>2</sup> Shows the short block length when calculating the enabled stroke range.  
141 mm (2 blocks total) for KR46 with 2 short blocks (D type, without QZ).

Stroke (mm) (Stroke between mechanical stoppers)	C type	220 (245.5)	320 (345.5)	420 (445.5)	520 (645.5)	620 (645.5)	720 (745.5)	820 (845.5)
	D type <sup>2</sup>	150 (173)	250 (273)	350 (373)	450 (473)	550 (673)	650 (673)	750 (773)
Maximum speed <sup>4</sup> (mm/s)	Ball screw lead: 5 mm	Normal grade/high accuracy grade		240				210
		Precision grade		340				210
	Ball screw lead: 10 mm	Normal grade/high accuracy grade		520				260
		Precision grade		740		650		490
Ball screw lead: 20 mm	Normal grade/high accuracy grade		1,050				490	390
	Precision grade		1,480		1,300		990	780
Dimensions (mm)	AL	440.5	540.5	640.5	740.5	840.5	940.5	1,040.5
	L	340	440	540	640	740	840	940
	C	200	300	400	500	600	700	800
	F	200	400	400	600	600	800	800
	H	70	20	70	20	70	20	70
No. of mounting holes	n	3	4	5	6	7	8	9
	n <sub>i</sub>	2	3	3	4	4	5	5
Mass <sup>5</sup> (kg)		6.2	7.6	9	10.4	11.8	13.2	14.6

<sup>3</sup> The value with 2 short blocks (D type, without QZ) attached.  
<sup>4</sup> The maximum speed is restricted by the actuator's permissible speed.  
<sup>5</sup> The mass with 2 short blocks (D type) has 0.6 kg added.

With Cover  
Motor Wrap

Dimensions

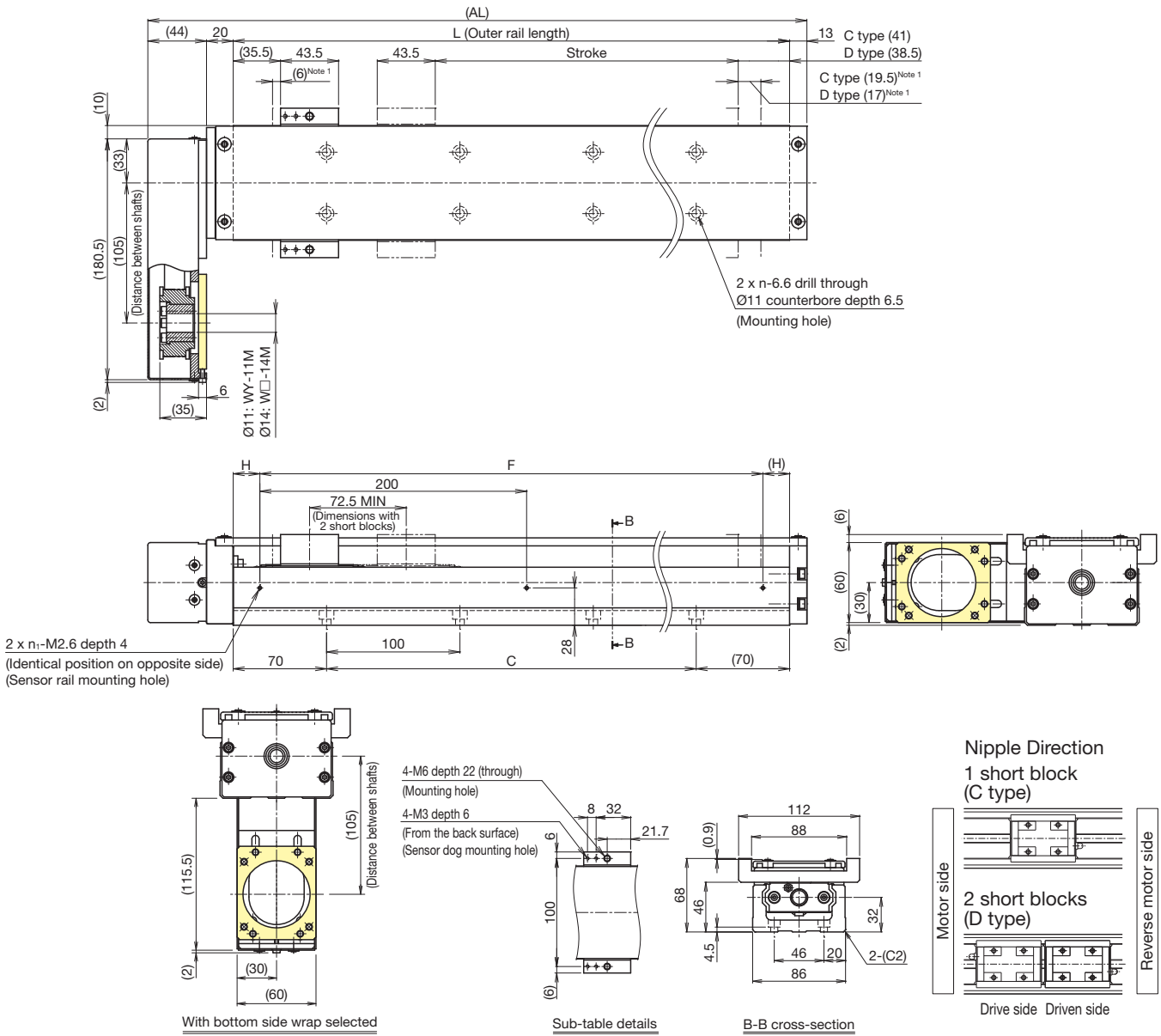

<sup>1</sup> Dimensions from the mechanical stopper to the stroke start position.

Stroke (mm) (Stroke between mechanical stoppers)	C type	220 (245.5)	320 (345.5)	420 (445.5)	520 (545.5)	620 (645.5)	720 (745.5)	820 (845.5)	
	D type <sup>2</sup>	150 (173)	250 (273)	350 (373)	450 (473)	550 (573)	650 (673)	750 (773)	
Maximum speed <sup>3</sup> (mm/s)	Ball screw lead: 5 mm	240							210
	Ball screw lead: 10 mm	740							260
	Ball screw lead: 20 mm	Normal grade/high accuracy grade	1,050					650	210
		Precision grade	1,480					490	210
Dimensions (mm)	AL	417	517	617	717	817	917	1,017	
	L	340	440	540	640	740	840	940	
	C	200	300	400	500	600	700	800	
	F	200	400	400	600	600	800	800	
	H	70	20	70	20	70	20	70	
No. of mounting holes	n	3	4	5	6	7	8	9	
	n <sub>1</sub>	2	3	3	4	4	5	5	
Mass <sup>4</sup> (kg)		8	9.4	10.9	12.4	13.9	15.4	16.8	

<sup>2</sup> The value with 2 short blocks (D type, without QZ) attached.

<sup>3</sup> The maximum speed is restricted by the actuator's permissible speed.

<sup>4</sup> The mass with 2 short blocks (D type) has 0.8 kg added.

Without Cover  
Motor Wrap

Dimensions

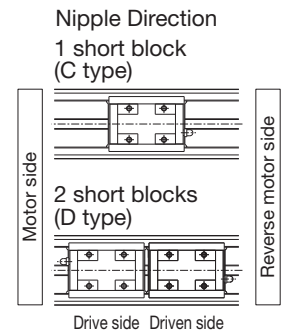
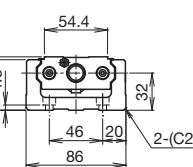
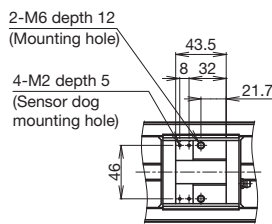
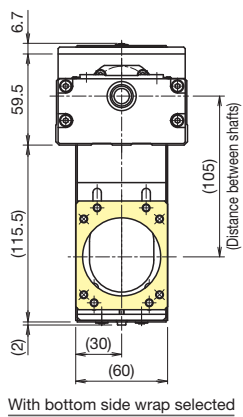
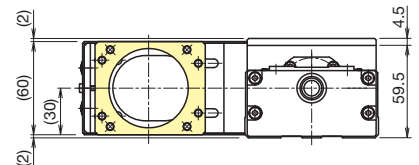
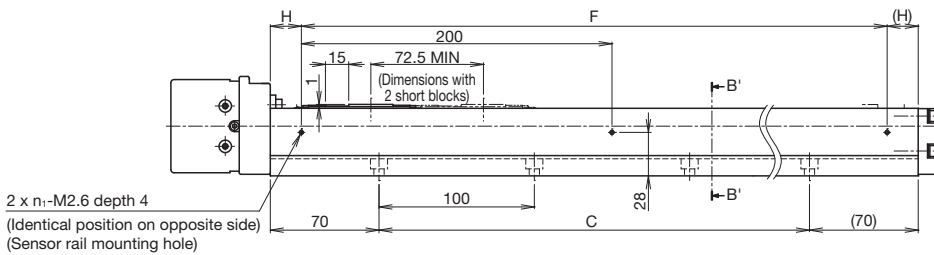
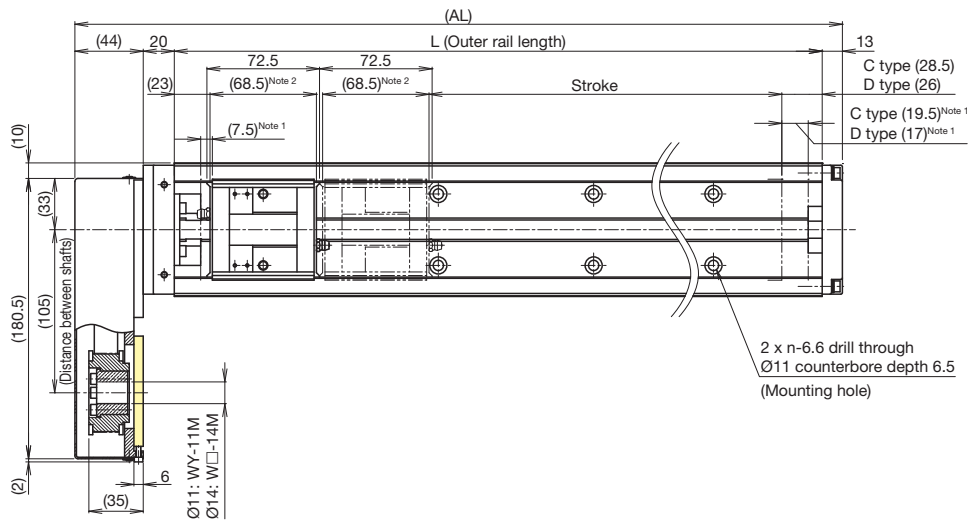

<sup>1</sup> Dimensions from the mechanical stopper to the stroke start position.  
<sup>2</sup> Shows the short block length when calculating the enabled stroke range. 141 mm (2 blocks total) for KR46 with 2 short blocks (D type, without QZ).

Stroke (mm) (Stroke between mechanical stoppers)	C type	220 (245.5)	320 (345.5)	420 (445.5)	520 (545.5)	620 (645.5)	720 (745.5)	820 (845.5)	
	D type <sup>2</sup>	150 (173)	250 (273)	350 (373)	450 (473)	550 (573)	650 (673)	750 (773)	
Maximum speed <sup>4</sup> (mm/s)	Ball screw lead: 5 mm	240						210	210
	Normal grade/high accuracy grade							260	210
	Precision grade							490	390
	Ball screw lead: 10 mm	740						650	490
Ball screw lead: 20 mm	Normal grade/high accuracy grade	1,050						990	780
	Precision grade	1,480						1,300	990
Dimensions (mm)	AL	417	517	617	717	817	917	1,017	
	L	340	440	540	640	740	840	940	
	C	200	300	400	500	600	700	800	
	F	200	400	400	600	600	800	800	
	H	70	20	70	20	70	20	70	
No. of mounting holes	n	3	4	5	6	7	8	9	
	n <sub>1</sub>	2	3	3	4	4	5	5	
Mass <sup>5</sup> (kg)		7.2	8.6	10	11.4	12.8	14.2	15.6	

<sup>3</sup> The value with 2 short blocks (D type, without QZ) attached.  
<sup>4</sup> The maximum speed is restricted by the actuator's permissible speed.  
<sup>5</sup> The mass with 2 short blocks (D type) has 0.6 kg added.

# Options

## Sensors

Optional photo sensors and proximity sensors are available. Sensor-equipped models also feature a dedicated sensor rail and sensor dog.

Sensors, sensor rails, and sensor dogs can be mounted on both sides when the stroke is less than 70 mm.

Mounting example

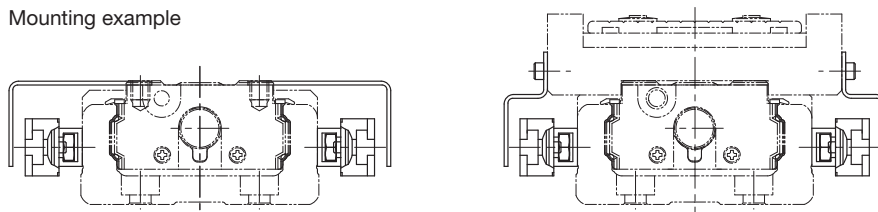

Symbol	Description	Model	Accessories
0	None	-	-
1	With sensor rail	-	Mounting screws, sensor rail (x1 or 2)
2	Photo sensor <sup>1</sup> (x3)	EE-SX671 (OMRON Corporation)	Mounting screws, nuts, sensor dog (x1 or 2), sensor rail (x1 or 2), mounting plates (x3), connectors (EE-1001 x3)
6	Photo sensor <sup>1</sup> (x3)	EE-SX674 (OMRON Corporation)	Mounting screws, nuts, sensor dog (x1 or 2), sensor rail (x1 or 2), mounting plates (x3), connectors (EE-1001 x3)
7	Proximity sensor N.O. contact <sup>2</sup> (x3)	APM-D3A1-001 (Azbil Corporation)	Mounting screws, nuts, sensor dog (x1 or 2), sensor rail (x1 or 2)
B	Proximity sensor N.C. contact <sup>3</sup> (x3)	APM-D3B1-003 (Azbil Corporation)	Mounting screws, nuts, sensor dog (x1 or 2), sensor rail (x1 or 2)
E	Proximity sensor N.O. contact <sup>2</sup> (x1) N.C. contact <sup>3</sup> (x2)	APM-D3A1-001 (Azbil Corporation) APM-D3B1-003 (Azbil Corporation)	Mounting screws, nuts, sensor dog (x1 or 2), sensor rail (x1 or 2)
H	Proximity sensor N.O. contact <sup>2</sup> (x3)	GX-F12A (Panasonic Industry Co., Ltd.)	Mounting screws, nuts, sensor dog (x1 or 2), sensor rail (x1 or 2)
L	Proximity sensor N.C. contact <sup>3</sup> (x3)	GX-F12B (Panasonic Industry Co., Ltd.)	Mounting screws, nuts, sensor dog (x1 or 2), sensor rail (x1 or 2)
J	Proximity sensor N.O. contact <sup>2</sup> (x1) N.C. contact <sup>3</sup> (x2)	GX-F12A (Panasonic Industry Co., Ltd.) GX-F12B (Panasonic Industry Co., Ltd.)	Mounting screws, nuts, sensor dog (x1 or 2), sensor rail (x1 or 2)
M	Proximity sensor N.O. contact <sup>2</sup> (x1) (PNP output) N.C. contact <sup>3</sup> (x2) (PNP output)	GX-F12A-P (Panasonic Industry Co., Ltd.) GX-F12B-P (Panasonic Industry Co., Ltd.)	Mounting screws, nuts, sensor dog (x1 or 2), sensor rail (x1 or 2)

<sup>1</sup> The photo sensors can be switched between ON when lit and ON when unlit.

<sup>2</sup> N.O. contact: Normally open contact point

<sup>3</sup> N.C. contact: Normally closed contact point

Notes: 1. If proximity sensors are close to one another, they may not function properly. If that happens, please prepare a type with a different frequency.

2. Mounting of sensors other than those in the table above is possible. Contact THK for details.

## Sensor Rail Mounting Dimensions

Mounting only a sensor rail is also possible.

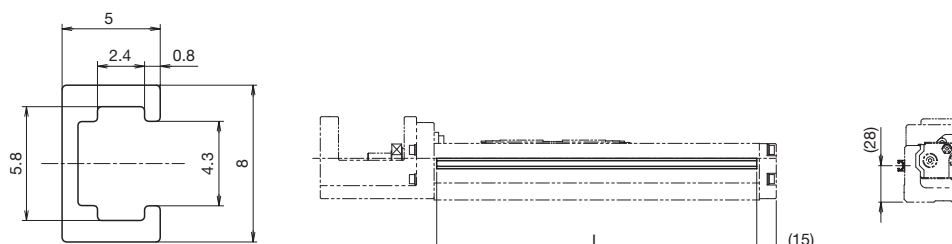

Sensor rail details

Stroke <sup>4</sup> (mm)	Outer rail length (mm)	L (mm)
190	340	336
290	440	436
390	540	536
490	640	636
590	740	736
690	840	836
790	940	936

<sup>4</sup> Stroke with 1 block (A type).

### Photo Sensor Mounting Dimensions

Connector: EE-1001 (OMRON Corporation) x3 included.  
To be mounted by the customer.

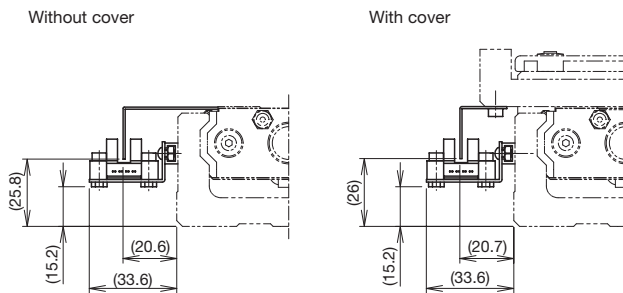

Symbol	Model	Manufacturer
2	EE-SX671	OMRON Corporation

Sensor dog width: 15 mm

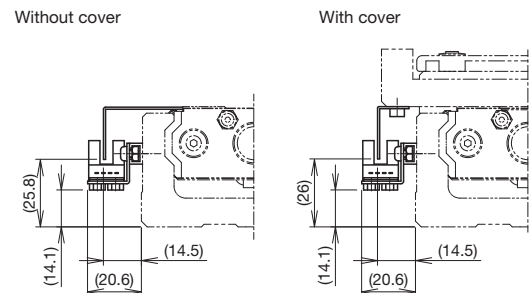

Symbol	Model	Manufacturer
6	EE-SX674	OMRON Corporation

Sensor dog width: 15 mm

### Proximity Sensor Mounting Dimensions

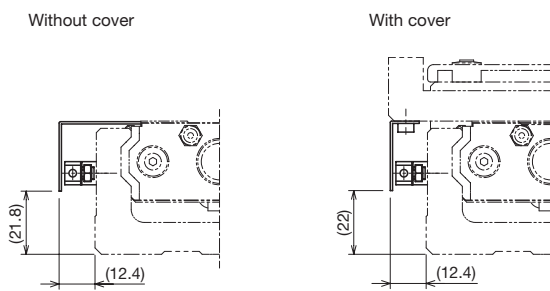

Symbol	Model	Manufacturer
7, B, E	APM-D3A1-001	Azbil Corporation
	APM-D3B1-003	

Sensor dog width: 15 mm

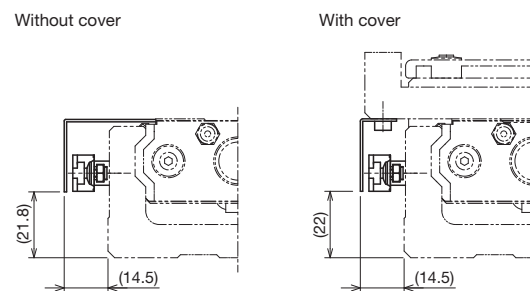

Symbol	Model	Manufacturer
H, L, J	GX-F12A	Panasonic Industry Co., Ltd.
	GX-F12B	
M	GX-F12A-P	
	GX-F12B-P	

Sensor dog width: 15 mm

# Options

## Intermediate Flange (Direct Coupling)

Several types of intermediate flanges for mounting motors are available.

When selecting "0" or "1" for Model Number Coding ⑦ With/without motor, specify an intermediate flange that matches the motor used.

Compatibility Table: Motors Used, Intermediate Flanges, and Couplings

Motor type	Manufacturer	Series	Motor model	Motor rated output (W)	Flange size	Housing A/ Intermediate flange	Compatible coupling models						
							MIKI PULLEY CO., LTD.	Nabeya Bi-tech Kaisha (NBK)					
AC servo motor	YASKAWA Electric Corporation	Σ-V	SGMJV-02	200	60×60	40	SFC-030DA2-8B-14B	XGT2-27C-8-14					
			SGMAV-02										
			SGMJV-04	400									
			SGMAV-04										
		SGMJV-06	600	60×60	40	SFC-030DA2-8B-14B	XGT2-30C-8-14						
		SGM7J-02	200										
		SGM7A-02											
		SGM7J-04	400										
		SGM7A-04											
		SGM7J-06	600	60×60	40	SFC-030DA2-8B-14B	XGT2-34C-8-14						
		SGMXJ-02	200										
		SGMXA-02											
	SGMXJ-04	400											
	SGMXA-04												
	SGMXJ-06	600	60×60	40	SFC-030DA2-8B-14B	XGT2-27C-8-14							
	SGMXA-06												
	SGMXJ-04	400											
	SGMXA-04												
	Mitsubishi Electric Corporation	MELSERVO	J4	HG-KR23	200	60×60	40	SFC-030DA2-8B-14B	XGT2-27C-8-14				
				HG-MR23									
				HG-KR43	400								
			HG-MR43										
			J5	HK-KT23W	200					60×60	40	SFC-030DA2-8B-14B	XGT2-27C-8-14
				HK-KT43W	400								
		JN		HF-KN23	200	60×60	40	SFC-030DA2-8B-14B	XGT2-27C-8-14				
			HF-KN43	400									
		TAMAGAWA SEIKI CO., LTD.	TBL-III	TS4607	200	60×60	40	SFC-030DA2-8B-14B	XGT2-27C-8-14				
				TS4609	400								
			TBL-IV	TSM3202	200					60×60	40	SFC-030DA2-8B-14B	XGT2-27C-8-14
				TSM3204	400								
	Panasonic Corporation	MINAS	A5	MSMD02	200	60×60	30	SFC-030DA2-8B-11B	XGT2-25C-8-11				
				MSME02									
				MSMD04	400								
			MSME04										
			A6	MSMF02	200					60×60	30	SFC-030DA2-8B-11B	XGT2-25C-8-11
		MHMF02											
KEYENCE CORPORATION		SV	SV-M020	200	60×60	40	SFC-030DA2-8B-14B	XGT2-27C-8-14					
			SV-M040	400									
		SV2	SV2-M020	200					60×60	40	SFC-030DA2-8B-14B	XGT2-27C-8-14	
			SV2-M040	400									
SANYO DENKI CO., LTD.	SANMOTION R	R2□A06020	200	60×60	40	SFC-030DA2-8B-14B	XGT2-27C-8-14						
		R2AA06040	400										
OMRON Corporation	OMNUC G5	R88M-K20030	200	60×60	30	SFC-030DA2-8B-11B	XGT2-25C-8-11						
		R88M-K40030	400										
	1S	R88M-1M20030	200					60×60	30	SFC-030DA2-8B-11B	XGT2-25C-8-11		
		R88M-1M40030	400										

Motor type	Manufacturer	Series	Motor model	Flange size	Housing A/ Intermediate flange	Compatible coupling models		
						MIKI PULLEY CO., LTD.	Nabeya Bi-tech Kaisha (NBK)	
Stepper motor	ORIENTAL MOTOR CO., LTD.	α step	AZ6*, AR6*	60×60	10	SFC-025DA2-8B-10B-L46	XGT2-25C-8-10	
		5-phase	CRK <sup>1</sup>	CRK56* (CRK569PM*)	60×60	10	SFC-025DA2-8B-8B-L46 (SFC-025DA2-8B-10B-L46)	XGT2-25C-8-8 (XGT2-25C-8-10)
			RK II	RKS56*	60×60	10	SFC-025DA2-10B-10B-L46	XGT2-25C-10-10
			PKP <sup>1</sup>	PKP56* (PKP569FM*)	60×60	10	SFC-025DA2-8B-8B-L46 (SFC-025DA2-8B-10B-L46)	XGT2-25C-8-8 (XGT2-25C-8-10)
	KEYENCE CORPORATION	2-phase	QS-M60	60×60	10	SFC-025DA2-8B-8B-L46	XGT2-25C-8-8	
	SANYO DENKI CO., LTD.	PB	PBDM60*, PBA**60*	60×60	10	SFC-025DA2-8B-10B-L46	XGT2-25C-8-10	
		5-phase	FAM56*/FDM56*/FA512M60/FB512M60	60×60	10	SFC-025DA2-8B-10B-L46	XGT2-25C-8-10	
		2-phase	DB16H78*	60×60	10	SFC-025DA2-8B-8B-L46	XGT2-25C-8-8	

<sup>1</sup> Items in parentheses have different motor shaft diameters and require a coupling to be specified.  
 Notes: 1. The table shows only a portion of the model numbers for motors. For details regarding model numbers, please see the catalog for each respective motor manufacturer.  
 2. If the maximum torque for motors exceeds the permissible input torque (A/B → p. 103, C/D → p. 111), please consider a safety measure to limit the torque.  
 3. When installing a motor other than the motor model numbers listed above, contact THK.



# Options

## Intermediate Flange (Motor Wrap)

Several types of intermediate flanges for mounting motors are available.

When selecting "R1," "R2," "R3," "R4," "R5," or "R6" for Model Number Coding ⑦ With/without motor, specify an intermediate flange that matches the motor used.

### Symbol Coding

Motor wrap symbol ①	Intermediate flange ②	Motor shaft diameter (mm) ③	Motor shaft securing method ④
W	V	14	M
W	Refer to the Compatibility Table: Motors Used and Motor Wrap Symbols below.	Specify a motor shaft diameter. (Refer to the Compatibility Table: Motors Used and Motor Wrap Symbols below.)	M: Friction tightening tool

### Motor Shaft Securing Method

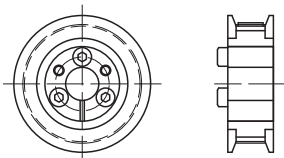

Friction tightening tool

Compatibility Table: Motors Used and Motor Wrap Symbols

Motor type	Manufacturer	Series	Motor model	Motor rated output (W)	Flange size	Housing A/Intermediate flange
AC servo motor	YASKAWA Electric Corporation	Σ-V	SGMJV-02	200	60×60	WV-14M
			SGMAV-02			
			SGMJV-04	400		
			SGMAV-04			
		SGMJV-06	600			
		Σ-7	SGM7J-02	200	60×60	
			SGM7A-02			
			SGM7J-04	400		
			SGM7A-04			
		SGM7J-06	600			
		Σ-X	SGMXJ-02	200	60×60	
			SGMXA-02			
	SGMXJ-04		400			
	SGMXA-04					
	SGMXJ-06	600				
	Mitsubishi Electric Corporation	MELSERVO	J4	HG-KR23	200	60×60
				HG-MR23		
			HG-KR43	400		
			HG-MR43			
		J5	HK-KT23W	200	60×60	
			HK-KT43W	400		
		JN	HF-KN23	200	60×60	
			HF-KN43	400		
	TAMAGAWA SEIKI CO., LTD.	TBL-iii	TS4607	200	60×60	
			TS4609	400		
		TBL-iv	TSM3202	200		60×60
			TSM3204	400		
	Panasonic Corporation	MINAS	A5	MSMD02	200	60×60
				MSME02		
			MSMD04	400		
			MSME04			
		A6	MSMF02	200	60×60	
MHMF02						
MSMF04			400			
MHMF04						
KEYENCE CORPORATION	SV	SV-M020	200	60×60		
		SV-M040	400			
	SV2	SV2-M020	200		60×60	
		SV2-M040	400			
SANYO DENKI CO., LTD.	SANMOTION R	R2□A06020	200	60×60		
		R2AA06040	400			
OMRON Corporation	OMNUC G5	R88M-K20030	200	60×60		
		R88M-K40030	400			
	1S	R88M-1M20030	200		60×60	
		R88M-1M40030	400			

Notes: 1. The table shows only a portion of the model numbers for motors. For details regarding model numbers, please see the catalog for each respective motor manufacturer.  
 2. If the maximum torque for motors exceeds the permissible input torque (A/B → p. 103, C/D → p. 111), please consider a safety measure to limit the torque.  
 3. When installing a motor other than the motor model numbers listed above, contact THK.

### Motor Wrap Housing A

KR46
60

KR**	Actuator model
●◇	●: Housing A ◇: Intermediate flange

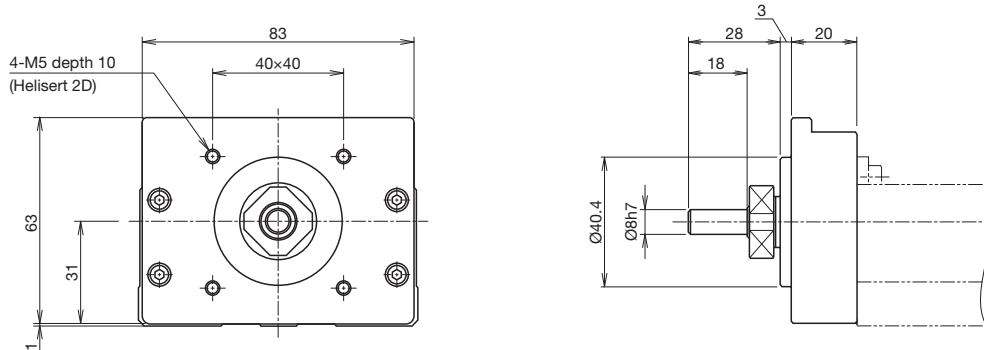

### Motor Wrap Specification (Intermediate Flange)

KR46
WV

Thickness: 6 mm

KR46
WY

Thickness: 6 mm

KR**	Actuator model
W□	□: Intermediate flange

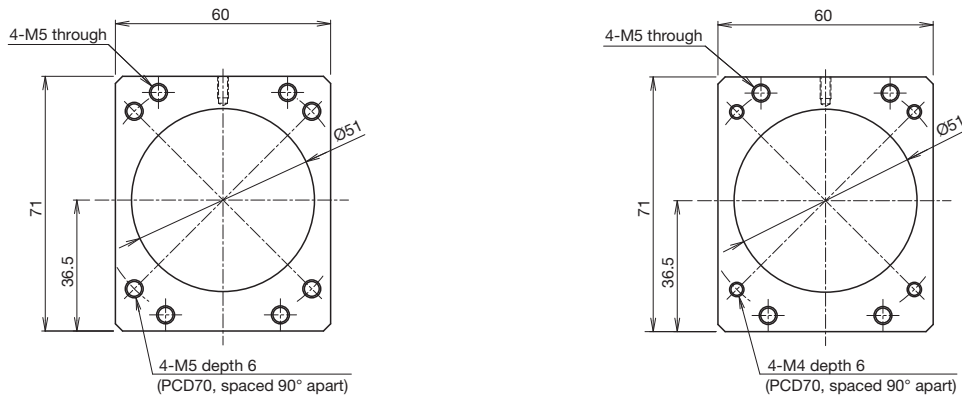

## Options

### QZ Lubricator

The QZ Lubricator for KR feeds the right amount of lubricant to the outer rail and ball screw shaft raceways. This allows an oil film to be constantly formed between the balls and the raceway, and it significantly extends the lubrication maintenance interval.

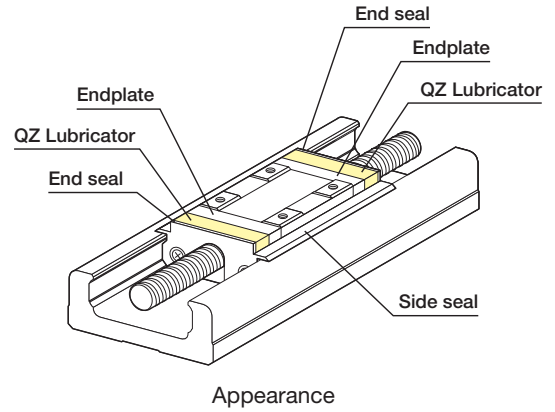

### Features

- Since it compensates for oil loss, the lubrication maintenance interval can be significantly extended.
- It is an eco-friendly lubrication system that does not contaminate the surrounding area, as it feeds the right amount of lubricant to the ball raceway.

### QZ Configuration

Symbol	Block type	Description
QZ	A/B/C/D	QZ all-block double-sided specification
QZA	A/C	QZ fixed side specification
QZB	A/C	QZ supported side specification
QZAD	B/D	QZ fixed side (drive side block) + QZ supported side (driven side block) specification

Note: QZ specification types do not have a grease nipple mounted. Contact THK if a grease nipple is required.

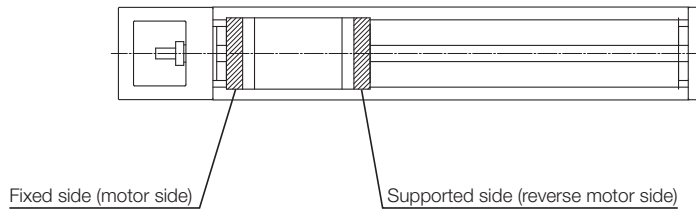

Block type \ QZ configuration	QZ	QZA	QZB	QZAD
A type (1 block)	 Fixed side      Supported side	 Fixed side      Supported side	 Fixed side      Supported side	-
B type (2 blocks)	 Fixed side      Supported side	-	-	 Fixed side      Supported side
C type (1 short block)	 Fixed side      Supported side	 Fixed side      Supported side	 Fixed side      Supported side	-
D type (2 short blocks)	 Fixed side      Supported side	-	-	 Fixed side      Supported side

### Dimensions with QZ Lubricator

QZ (With Cover)  
Block Type: A/B/C/D

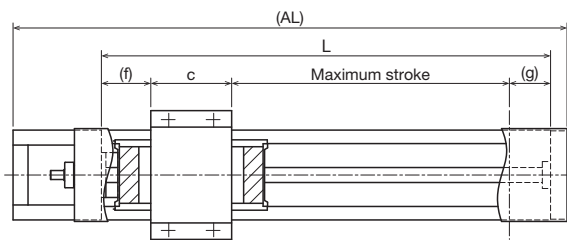

Block Type A/C

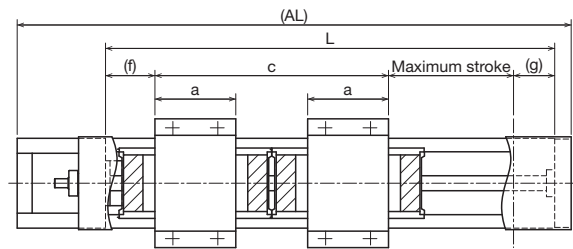

Block Type B/D

Unit: mm

Block type	Overall length AL	Outer rail length L	Stroke <sup>1</sup>	Maximum stroke <sup>1</sup>	a	c	f	g
A	440.5	340	160	178	-	81	44.5	36.5
	540.5	440	260	278				
	640.5	540	360	378				
	740.5	640	460	478				
	840.5	740	560	578				
	940.5	840	660	678				
	1,040.5	940	760	778				
B	540.5	440	120	138	81	221	44.5	36.5
	640.5	540	220	238				
	740.5	640	320	338				
	840.5	740	420	438				
	940.5	840	520	538				
	1,040.5	940	620	638				
C	440.5	340	190	215.5	-	43.5	44.5	36.5
	540.5	440	290	315.5				
	640.5	540	390	415.5				
	740.5	640	490	515.5				
	840.5	740	590	615.5				
	940.5	840	690	715.5				
	1,040.5	940	790	815.5				
D	440.5	340	90	113	43.5	146	44.5	36.5
	540.5	440	190	213				
	640.5	540	290	313				
	740.5	640	390	413				
	840.5	740	490	513				
	940.5	840	590	613				
		1,040.5	940	690				

<sup>1</sup> The value for B/D block types is with 2 blocks attached.

## Options

### Dimensions with QZ Lubricator

QZ (Without Cover)  
Block Type: A/B/C/D

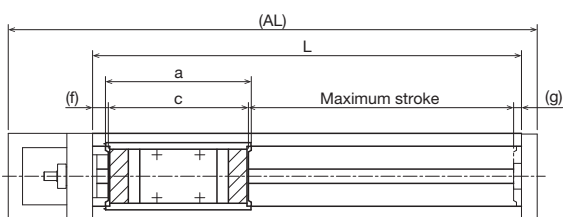

Block Type A/C

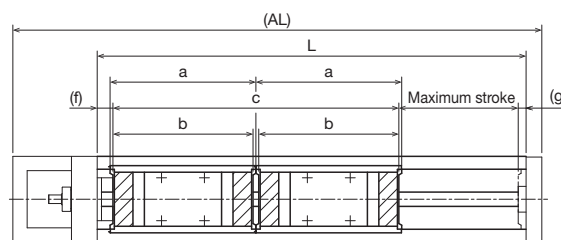

Block Type B/D

Unit: mm

Block type	Overall length AL	Outer rail length L	Stroke <sup>1</sup>	Maximum stroke <sup>1</sup>	a	b	c	f	g					
A	440.5	340	160	178	140	-	136	17	9					
	540.5	440	260	278										
	640.5	540	360	378										
	740.5	640	460	478										
	840.5	740	560	578										
	940.5	840	660	678										
	1,040.5	940	760	778										
B	540.5	440	120	138	140	136	276	17	9					
	640.5	540	220	238										
	740.5	640	320	338										
	840.5	740	420	438										
	940.5	840	520	538										
	1,040.5	940	620	638										
C	440.5	340	190	215.5	102.5	-	98.5	17	9					
	540.5	440	290	315.5										
	640.5	540	390	415.5										
	740.5	640	490	515.5										
	840.5	740	590	615.5										
	940.5	840	690	715.5										
	1,040.5	940	790	815.5										
D	440.5	340	90	113	102.5	98.5	201	17	9					
	540.5	440	190	213										
	640.5	540	290	313										
	740.5	640	390	413										
	840.5	740	490	513										
	940.5	840	590	613										
	1,040.5	940	690	713										

<sup>1</sup> The value for B/D block types is with 2 blocks attached.

### Dimensions with QZ Lubricator

**QZA (With Cover)**  
Block Type: A/C

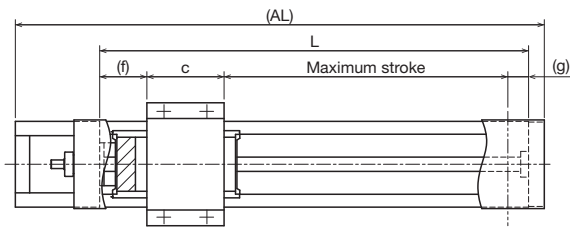

Block Type A/C

**QZA (Without Cover)**  
Block Type: A/C

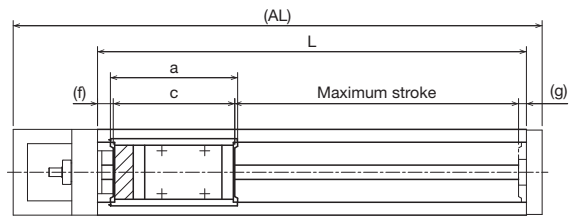

Block Type A/C

**QZA (With Cover)**

Unit: mm

Block type	Overall length AL	Outer rail length L	Stroke	Maximum stroke	c	f	g
A	440.5	340	175	193	81	44.5	21.5
	540.5	440	275	293			
	640.5	540	375	393			
	740.5	640	475	493			
	840.5	740	575	593			
	940.5	840	675	693			
C	1,040.5	940	775	793	43.5	44.5	21.5
	440.5	340	205	230.5			
	540.5	440	305	330.5			
	640.5	540	405	430.5			
	740.5	640	505	530.5			
	840.5	740	605	630.5			
940.5	840	705	730.5				
1,040.5	940	805	830.5				

Note 1: B/D block types cannot be selected for QZA.

**QZA (Without Cover)**

Unit: mm

Block type	Overall length AL	Outer rail length L	Stroke	Maximum stroke	a	c	f	g
A	440.5	340	175	193	125	121	17	9
	540.5	440	275	293				
	640.5	540	375	393				
	740.5	640	475	493				
	840.5	740	575	593				
	940.5	840	675	693				
C	1,040.5	940	775	793	87.5	83.5	17	9
	440.5	340	205	230.5				
	540.5	440	305	330.5				
	640.5	540	405	430.5				
	740.5	640	505	530.5				
	840.5	740	605	630.5				
940.5	840	705	730.5					
1,040.5	940	805	830.5					

Note 2: B/D block types cannot be selected for QZA.

## Options

### Dimensions with QZ Lubricator

QZB (With Cover)  
Block Type: A/C

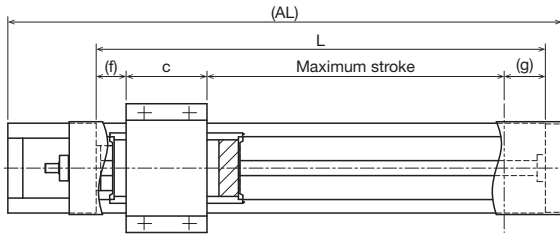

Block Type A/C

QZB (Without Cover)  
Block Type: A/C

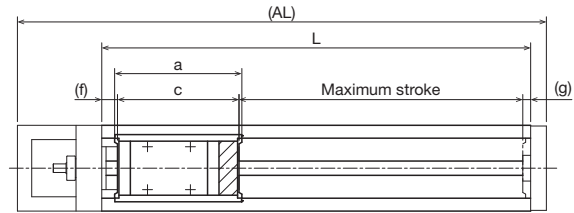

Block Type A/C

QZB (With Cover)

Unit: mm

Block type	Overall length AL	Outer rail length L	Stroke	Maximum stroke	c	f	g
A	440.5	340	175	193	81	29.5	36.5
	540.5	440	275	293			
	640.5	540	375	393			
	740.5	640	475	493			
	840.5	740	575	593			
	940.5	840	675	693			
	1,040.5	940	775	793			
C	440.5	340	205	230.5	43.5	29.5	36.5
	540.5	440	305	330.5			
	640.5	540	405	430.5			
	740.5	640	505	530.5			
	840.5	740	605	630.5			
	940.5	840	705	730.5			
	1,040.5	940	805	830.5			

Note 1: B/D block types cannot be selected for QZB.

QZB (Without Cover)

Unit: mm

Block type	Overall length AL	Outer rail length L	Stroke	Maximum stroke	a	c	f	g
A	440.5	340	175	193	125	121	17	9
	540.5	440	275	293				
	640.5	540	375	393				
	740.5	640	475	493				
	840.5	740	575	593				
	940.5	840	675	693				
	1,040.5	940	775	793				
C	440.5	340	205	230.5	87.5	83.5	17	9
	540.5	440	305	330.5				
	640.5	540	405	430.5				
	740.5	640	505	530.5				
	840.5	740	605	630.5				
	940.5	840	705	730.5				
	1,040.5	940	805	830.5				

Note 2: B/D block types cannot be selected for QZB.

### Dimensions with QZ Lubricator

#### QZAD (With Cover)

Block Type: B/D

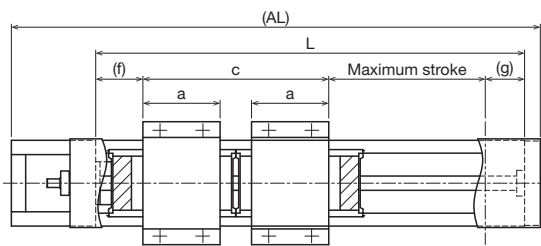

Block Type B/D

#### QZAD (Without Cover)

Block Type: B/D

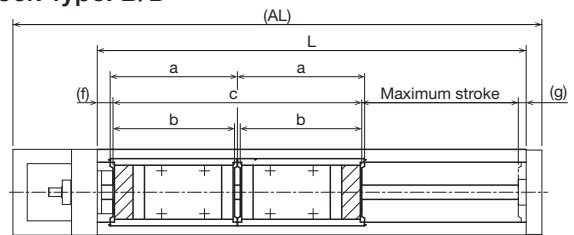

Block Type B/D

#### QZAD (With Cover)

Unit: mm

Block type	Overall length AL	Outer rail length L	Stroke <sup>1</sup>	Maximum stroke <sup>1</sup>	a	c	f	g
B	540.5	440	150	168	81	191	44.5	36.5
	640.5	540	250	268				
	740.5	640	350	368				
	840.5	740	450	468				
	940.5	840	550	568				
	1,040.5	940	650	668				
D	440.5	340	120	143	43.5	116	44.5	36.5
	540.5	440	220	243				
	640.5	540	320	343				
	740.5	640	420	443				
	840.5	740	520	543				
	940.5	840	620	643				
	1,040.5	940	720	743				

<sup>1</sup> The value for B/D block types is with 2 blocks attached.

Note 1: A/C block types cannot be selected for QZAD.

#### QZAD (Without Cover)

Unit: mm

Block type	Overall length AL	Outer rail length L	Stroke <sup>2</sup>	Maximum stroke <sup>2</sup>	a	b	c	f	g
B	540.5	440	150	168	125	121	246	17	9
	640.5	540	250	268					
	740.5	640	350	368					
	840.5	740	450	468					
	940.5	840	550	568					
	1,040.5	940	650	668					
D	440.5	340	120	143	87.5	83.5	171	17	9
	540.5	440	220	243					
	640.5	540	320	343					
	740.5	640	420	443					
	840.5	740	520	543					
	940.5	840	620	643					
	1,040.5	940	720	743					

<sup>2</sup> The value for B/D block types is with 2 blocks attached.

Note 2: A/C block types cannot be selected for QZAD.

# KR55 A/B

Direct motor coupling	Motor wrap	Width 100 mm	Height 55 mm	Max. stroke 1,200 mm
-----------------------	------------	--------------	--------------	----------------------

## Model Number Coding

Model	Ball screw lead	Block type	QZ specification	Stroke	Accuracy grade	With/without motor	Cover	Sensors	Housing A/ Intermediate flange
①	②	③	④	⑤	⑥	⑦	⑧	⑨	⑩
KR55	20	A	QZA	0785	P	0	1	2	A0
<b>KR55</b>	<b>20: 20 mm</b>	<b>A: x1</b> <b>B: x2</b>	<b>No symbol: Without QZ</b> <b>QZ</b> <b>QZA</b> <b>QZB</b> <b>QZAD</b>	<b>0680: 680 mm</b> to <b>1200: 1,200 mm</b>  When selecting ②: With bellows for ⑧ Cover, specify the stroke with bellows. → p. 165 to p. 166	<b>No symbol: Normal grade</b> <b>H: High accuracy grade</b> <b>P: Precision grade</b>	<b>With direct coupling</b> <b>0: Direct coupling (without motor)</b> <b>1: Direct coupling (THK will purchase and mount the motor you specify.)</b>  <b>With motor wrap</b> <b>R1: Non-standard side wrap (without motor)</b> <b>R2: Standard side wrap (without motor)</b> <b>R3: Bottom side wrap (without motor)</b>  <b>R4: Non-standard side wrap (THK will purchase and mount the motor you specify.)</b> <b>R5: Standard side wrap (THK will purchase and mount the motor you specify.)</b> <b>R6: Bottom side wrap (THK will purchase and mount the motor you specify.)</b>  When selecting "0": A coupling is not provided. Indicate when placing an order if a coupling is required.  When selecting "1," "R4," "R5," or "R6": The specified motor will be installed. Indicate the motor cable direction separately. Select ⑩ Intermediate flange to match the specified motor.	<b>0: Without cover</b> <b>1: With cover</b> <b>2: With bellows</b>	<b>0</b> <b>1</b> <b>2</b> <b>6</b> <b>7</b> <b>B</b> <b>E</b> <b>H</b> <b>L</b> <b>J</b> <b>M</b>	<b>With direct coupling</b> <b>A0</b> <b>AZ</b> <b>A5</b> <b>A6</b> <b>20</b> <b>With motor wrap</b> <b>WV - 14M</b> <b>WZ - 16M</b> <b>WZ - 19M</b> <b>W5 - 19M</b>

Sensor details With direct coupling → p. 141  
→ p. 139 With motor wrap → p. 143

### ③ Block Type

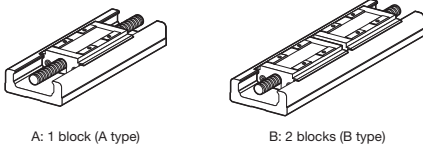

### ⑦ Motor Mounting Method

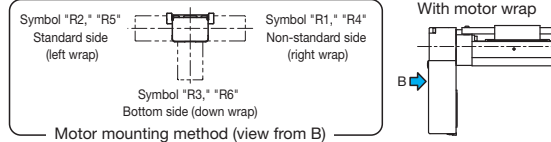

## Selection Information

### Basic Specifications

LM Guide	Basic dynamic load rating C (N)		48,900
	Basic static load rating C <sub>0</sub> (N)		70,200
	Radial clearance (mm)	Normal grade/High accuracy grade (H)	-0.007 to +0.004
		Precision grade (P)	-0.019 to -0.007
Geometric moment of inertia	I <sub>x</sub> <sup>1</sup> (mm <sup>4</sup> )	2.2×10 <sup>5</sup>	
	I <sub>y</sub> <sup>2</sup> (mm <sup>4</sup> )	2.3×10 <sup>5</sup>	
	Mass (kg/m)	15	
Ball screw	Ball screw lead (mm)		20
	Basic dynamic load rating Ca (N)	Normal grade/High accuracy grade (H)	3,620
		Precision grade (P)	3,980
	Basic static load rating C <sub>0a</sub> (N)	Normal grade/High accuracy grade (H)	9,290
		Precision grade (P)	6,850
	Screw shaft diameter (mm)		Ø20
	Thread minor diameter (mm)		Ø17.5
	Ball center-to-center diameter (mm)		Ø20.75
Permissible rotational speed <sup>3</sup> (min <sup>-1</sup> )	Normal grade/High accuracy grade (H)	2,400	
	Precision grade (P)	3,360	
Bearing unit (fixed side)	Axial direction	Basic dynamic load rating Ca (N)	7,600
		Static permissible load P <sub>0a</sub> (N)	3,990
Permissible input torque (N·m)	Direct coupling		8.5
	Motor wrap <sup>4</sup>		6.8 (6.4)
Static permissible moment <sup>5,6</sup> (N·m)		M <sub>A</sub> : 870 (4,890), M <sub>B</sub> : 870 (4,890), M <sub>C</sub> : 2,280 (4,570)	
Service life <sup>7</sup> (km)		10,000	
Standard grease/Grease nipple used		THK AFB-LF Grease/A-M6F	

- <sup>1</sup> I<sub>x</sub> is the geometric moment of inertia about the X axis.  
<sup>2</sup> I<sub>y</sub> is the geometric moment of inertia about the Y axis.  
<sup>3</sup> The permissible rotational speed may decrease as the stroke becomes longer.  
<sup>4</sup> The values in parentheses are for precision grade.  
<sup>5</sup> The value in parentheses is with 2 blocks (B type) attached.  
<sup>6</sup> See p. 172 for the values if "1" or "2" is selected for item ⑧ in the Model Number Coding.  
<sup>7</sup> Calculated under the following conditions.  
 Stroke: 1,000 mm (A type), 880 mm (B type) / Speed: 800 mm/s (for 20 mm lead) / Load mass: Maximum load capacity (p. 9) / Acceleration/deceleration: As when set to maximum load capacity (p. 9) / Center of gravity: Center of the table's upper surface.  
 Notes: 1. LM Guide load rating is the load rating per block.  
 2. Precision grade (P-grade) ball screws have integrated spacer balls with a 2:1 ratio.

### Geometric Moment of Inertia

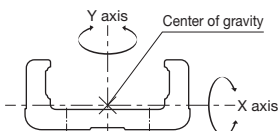

### Static Permissible Moment

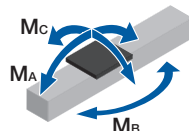

### Accuracy

Accuracy grade	Item	Stroke <sup>8</sup>				
		800	900	1,000	1,100	1,200
Normal grade (no symbol)	Positioning repeatability (mm)	±0.01				
	Positioning accuracy (mm)	Not specified				
	Running parallelism (vertical direction) (mm)	Not specified				
	Backlash (mm)	0.05				
	Starting torque (N·cm)	12				
High accuracy grade (H)	Positioning repeatability (mm)	±0.005				
	Positioning accuracy (mm)	0.18	0.25			
	Running parallelism (vertical direction) (mm)	0.05				
	Backlash (mm)	0.05				
	Starting torque (N·cm)	12				
Precision grade (P)	Positioning repeatability (mm)	±0.005				
	Positioning accuracy (mm)	0.035	0.04			
	Running parallelism (vertical direction) (mm)	0.025	0.03			
	Backlash (mm)	0.003				
	Starting torque (N·cm)	17	20			

- <sup>8</sup> Stroke with 1 block (A type, without QZ).  
 Notes: 3. Precision evaluation in accordance with THK standards.  
 4. Measured using a motor for inspection. With motor wrap specifications, measurements are not made in the completed motor wrap state.  
 5. The starting torque represents the value when containing THK AFB-LF Grease.  
 6. The starting torque may exceed standards if using vacuum grease, clean room grease, or other high-viscosity greases, so care should be taken when selecting a motor.  
 7. Contact THK for accuracy higher than the standard stroke.

### Motor Selection Information

Stroke <sup>1</sup> (mm)	Outer rail length (mm)	LM Guide				Sliding resistance value <sup>2</sup> (N)	Ball screw		Motor mounting part	
		Moving part mass (kg)			Lead (mm)		Shaft length (mm)	Direct coupling	Motor wrap	
		Block mass	Sub-table mass	Total mass				Shaft end diameter (mm)	Timing pulley (sum of two) Inertial moment x 10 <sup>-4</sup> (kg·m <sup>2</sup> )	
800 to 1,200	980 to 1,380	A type: 1.8 B type: 3.6	A type: 1.9 B type: 3.8	A type: 3.7 B type: 7.4	8.8	20	1,054 to 1,454	Ø12h7	1.432	

<sup>1</sup> Stroke with 1 block (A type, without QZ).

<sup>2</sup> Value with 1 block (A type, without QZ). This value is the sum of the rolling resistance value and seal resistance value.

Note: Refer to p. 141 for applicable couplings.

### Permissible Overhang Length<sup>3</sup>

Horizontal

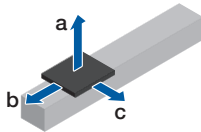

Wall-Mounted

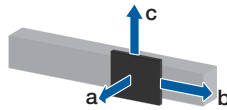

Vertical

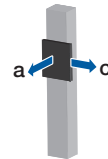

Estimated motor capacity 400 W		Ball screw lead (mm)	Load mass (kg)	a (mm)	b (mm)	c (mm)
Direct coupling	A type	20	11	1,000	560	580
			22	930	270	290
			44	440	130	140
	B type	20	10	1,000	1,000	1,000
			20	1,000	1,000	640
			40.5	1,000	810	310
Motor wrap	A type	20	6.5	1,000	960	990
			13	1,000	470	490
			26	780	230	240
	B type	20	7	1,000	1,000	1,000
			14.5	1,000	1,000	890
			29.5	1,000	1,000	430

Estimated motor capacity 400 W		Ball screw lead (mm)	Load mass (kg)	a (mm)	b (mm)	c (mm)
Direct coupling	A type	20	11	530	490	1,000
			22	240	240	810
			44	90	110	400
	B type	20	10	1,000	1,000	1,000
			20	590	1,000	1,000
			40.5	260	520	1,000
Motor wrap	A type	20	6.5	940	830	1,000
			13	440	410	1,000
			26	190	200	690
	B type	20	7	1,000	1,000	1,000
			14.5	830	1,000	1,000
			29.5	380	710	1,000

Estimated motor capacity 400 W		Ball screw lead (mm)	Load mass (kg)	a (mm)	c (mm)
Direct coupling	A type	20	4	1,000	1,000
			8.5	530	480
			17	240	240
	B type	20	4	1,000	1,000
			8.5	1,000	1,000
			17	1,000	950
Motor wrap	A type	20	2.5	1,000	1,000
			5.5	850	750
			11.5	380	360
	B type	20	2.5	1,000	1,000
			5.5	1,000	1,000
			11.5	1,000	1,000

Estimated motor capacity 750 W		Ball screw lead (mm)	Load mass (kg)	a (mm)	b (mm)	c (mm)
Direct coupling	A type	20	21	970	290	300
			42	460	130	150
			84	200	60	70
	B type	20	23.5	1,000	1,000	550
			47	1,000	700	270
			94.5	1,000	340	130
Motor wrap	A type	20	18.5	1,000	330	340
			37	530	160	170
			74	240	70	80
	B type	20	20.5	1,000	1,000	630
			41.5	1,000	790	310
			83.5	1,000	390	150

Estimated motor capacity 750 W		Ball screw lead (mm)	Load mass (kg)	a (mm)	b (mm)	c (mm)
Direct coupling	A type	20	18.5	290	290	970
			37.5	110	130	480
			75	30	50	240
	B type	20	23.5	490	900	1,000
			47	220	450	1,000
			94.5	80	220	740
Motor wrap	A type	20	18.5	290	290	970
			37	120	140	480
			74	30	50	240
	B type	20	20.5	570	1,000	1,000
			41.5	250	510	1,000
			83.5	100	250	840

Estimated motor capacity 750 W		Ball screw lead (mm)	Load mass (kg)	a (mm)	c (mm)
Direct coupling	A type	20	8	570	520
			16	260	260
			32.5	100	120
	B type	20	7	1,000	1,000
			14.5	1,000	1,000
			29	820	560
Motor wrap	A type	20	8	570	520
			16	260	260
			32.5	100	120
	B type	20	7	1,000	1,000
			14.5	1,000	1,000
			29	820	560

<sup>3</sup> This is the value with the service life of the LM Guide limited to 10,000 km. The calculation conditions are as follows.  
Stroke: 1,000 mm (A type), 880 mm (B type) / Acceleration/deceleration: 0.3 G / Speed: 800 mm/s (for 20 mm lead) / Overhang direction: Loaded only in a single direction. Dimensions a, b, and c are from the center of the table's upper surface.

Without Cover  
Direct Motor Coupling

Dimensions

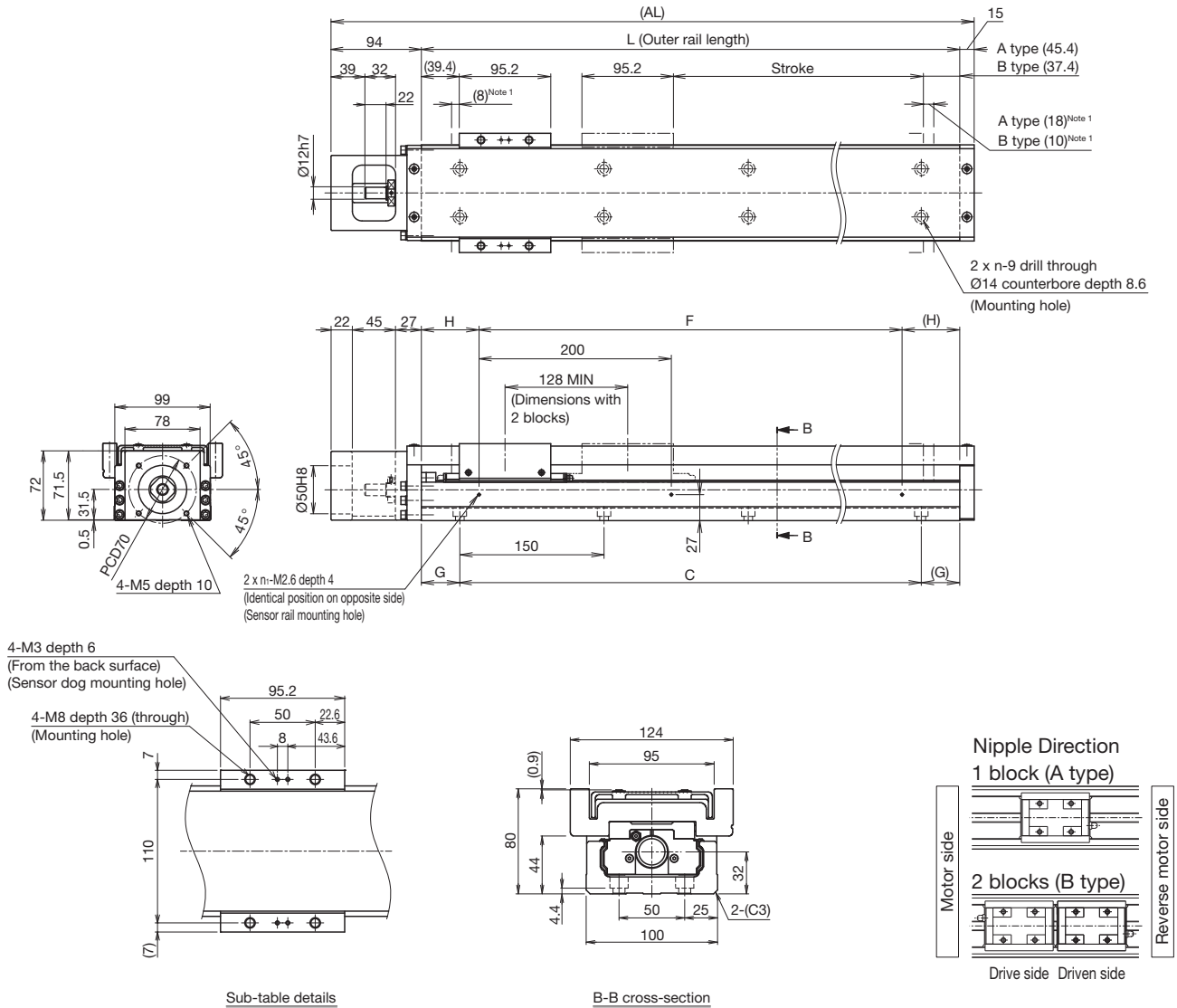

<sup>1</sup> Dimensions from the mechanical stopper to the stroke start position.

Stroke (mm) (Stroke between mechanical stoppers)	A type		800 (826)	900 (926)	1,000 (1,026)	1,100 (1,126)	1,200 (1,226)
	B type <sup>2</sup>		680 (698)	780 (798)	880 (898)	980 (998)	1,080 (1,098)
Maximum speed <sup>3</sup> (mm/s)	Ball screw lead: 20 mm	Normal grade/high accuracy grade	800		740	620	530
		Precision grade	1,120	900	740	-	-
Dimensions (mm)	AL		1,089	1,189	1,289	1,389	1,489
	L		980	1,080	1,180	1,280	1,380
	C		900	1,050	1,050	1,200	1,350
	G		40	15	65	40	15
	F		800	1,000	1,000	1,200	1,200
	H		90	40	90	40	90
No. of mounting holes	n		7	8	8	9	10
	n <sub>1</sub>		5	6	6	7	7
Mass <sup>4</sup> (kg)		24.1		25.9	27.7	29.6	31.4

<sup>2</sup> The value with 2 blocks (B type, without QZ) attached.

<sup>3</sup> The maximum speed is restricted by the actuator's permissible speed.

<sup>4</sup> The mass with 2 blocks (B type) has 3.7 kg added.

Without Cover  
Direct Motor Coupling

**Dimensions**

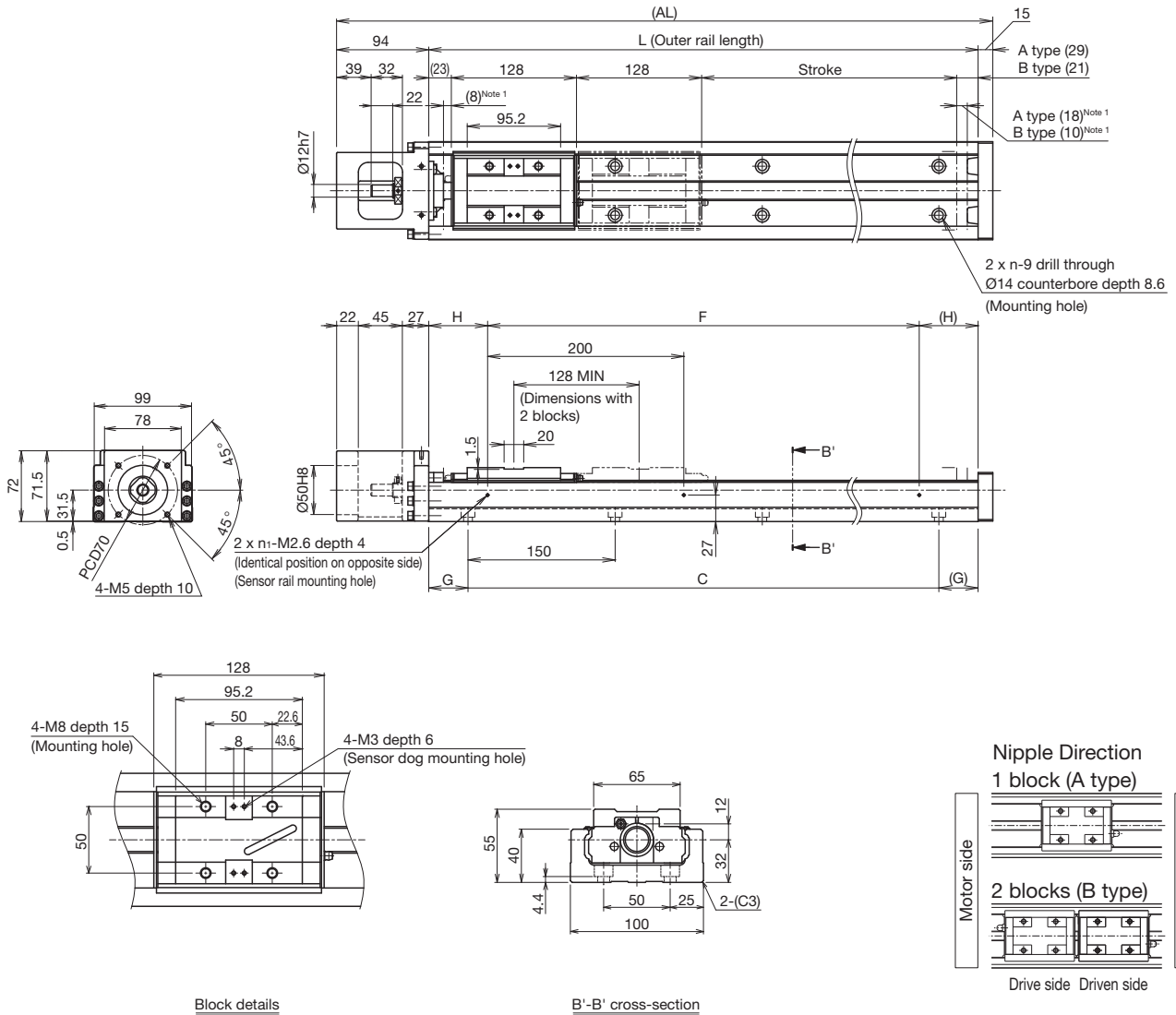

<sup>1</sup> Dimensions from the mechanical stopper to the stroke start position.

Stroke (mm) (Stroke between mechanical stoppers)	A type		800 (826)	900 (926)	1,000 (1,026)	1,100 (1,126)	1,200 (1,226)
	B type <sup>2</sup>		680 (698)	780 (798)	880 (898)	980 (998)	1,080 (1,098)
Maximum speed <sup>3</sup> (mm/s)	Ball screw lead: 20 mm	Normal grade/high accuracy grade	800		740	620	530
		Precision grade	1,120	900	740	-	-
Dimensions (mm)	AL		1,089	1,189	1,289	1,389	1,489
	L		980	1,080	1,180	1,280	1,380
	C		900	1,050	1,050	1,200	1,350
	G		40	15	65	40	15
	F		800	1,000	1,000	1,200	1,200
	H		90	40	90	40	90
No. of mounting holes	n		7	8	8	9	10
	n <sub>1</sub>		5	6	6	7	7
Mass <sup>4</sup> (kg)			20.2	21.9	23.6	25.4	27.1

<sup>2</sup> The value with 2 blocks (B type, without QZ) attached.

<sup>3</sup> The maximum speed is restricted by the actuator's permissible speed.

<sup>4</sup> The mass with 2 blocks (B type) has 1.8 kg added.

With Cover Motor Flange Size 60x60  
Motor Wrap

Dimensions

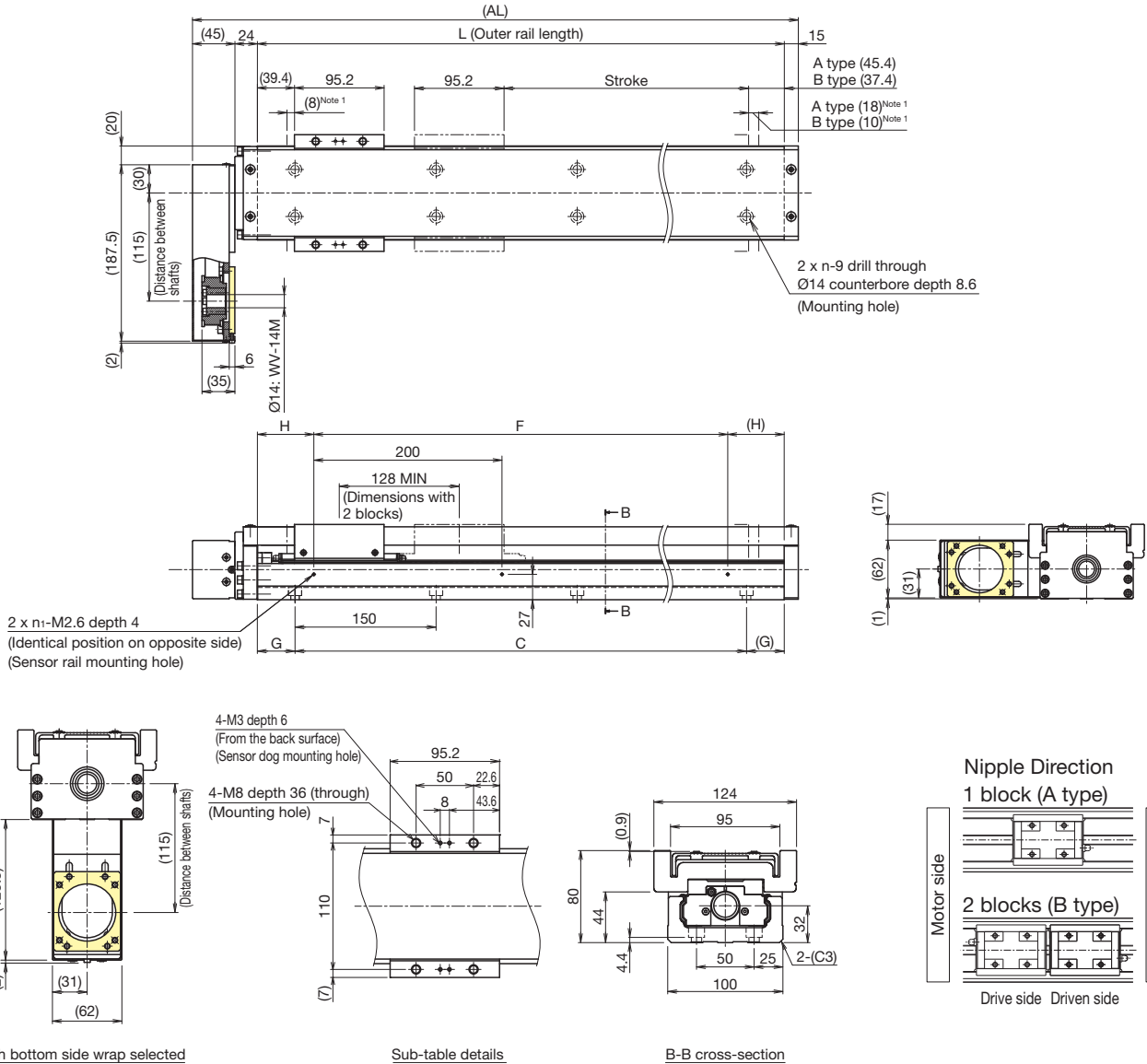

<sup>1</sup> Dimensions from the mechanical stopper to the stroke start position.

Stroke (mm) (Stroke between mechanical stoppers)	A type	800 (826)	900 (926)	1,000 (1,026)	1,100 (1,126)	1,200 (1,226)
	B type <sup>2</sup>	680 (698)	780 (798)	880 (898)	980 (998)	1,080 (1,098)
Maximum speed <sup>3</sup> (mm/s)	Ball screw lead: 20 mm	800		740	620	530
	Normal grade/high accuracy grade	1,120	900	740	-	-
	Precision grade	1,064	1,164	1,264	1,364	1,464
Dimensions (mm)	AL	980	1,080	1,180	1,280	1,380
	L	900	1,050	1,050	1,200	1,350
	C	40	15	65	40	15
	F	800	1,000	1,000	1,200	1,200
	H	90	40	90	40	90
No. of mounting holes	n	7	8	8	9	10
	n <sub>1</sub>	5	6	6	7	7
	Mass <sup>4</sup> (kg)	25	26.8	28.6	30.5	32.3

<sup>2</sup> The value with 2 blocks (B type, without QZ) attached.  
<sup>3</sup> The maximum speed is restricted by the actuator's permissible speed.  
<sup>4</sup> The mass with 2 blocks (B type) has 3.7 kg added.

Without Cover Motor Flange Size 60x60  
Motor Wrap

**Dimensions**

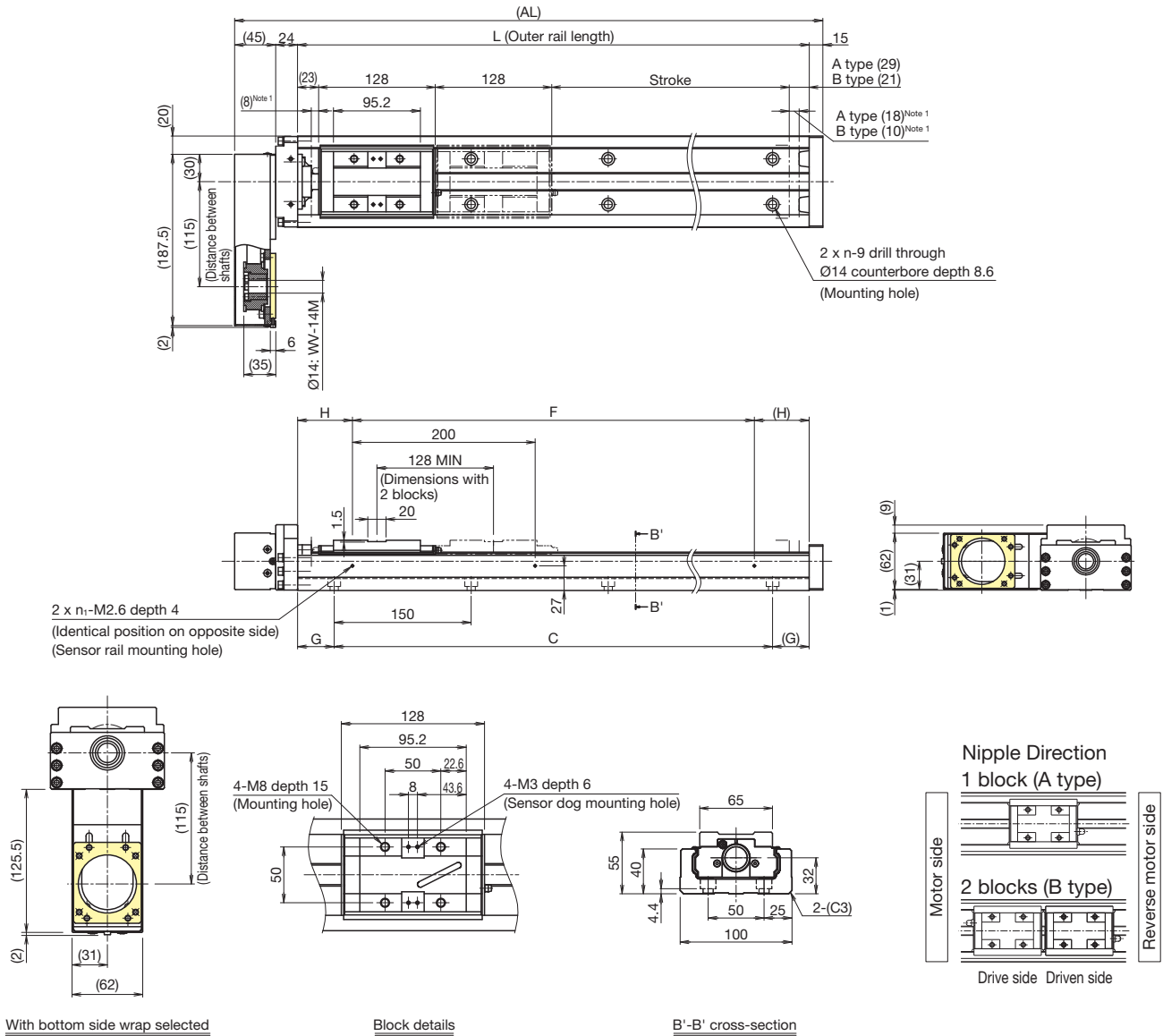

<sup>1</sup> Dimensions from the mechanical stopper to the stroke start position.

Stroke (mm) (Stroke between mechanical stoppers)	A type	800 (826)	900 (926)	1,000 (1,026)	1,100 (1,126)	1,200 (1,226)
		B type <sup>2</sup>	680 (698)	780 (798)	880 (898)	980 (998)
Maximum speed <sup>3</sup> (mm/s)	Ball screw lead:	800				
	20 mm	Normal grade/high accuracy grade	740	900	740	620
Dimensions (mm)	AL	1,064	1,164	1,264	1,364	1,464
	L	980	1,080	1,180	1,280	1,380
	C	900	1,050	1,050	1,200	1,350
	G	40	15	65	40	15
	F	800	1,000	1,000	1,200	1,200
	H	90	40	90	40	90
No. of mounting holes	n	7	8	8	9	10
	n <sub>1</sub>	5	6	6	7	7
Mass <sup>4</sup> (kg)		21.1	22.8	24.5	26.3	28

<sup>2</sup> The value with 2 blocks (B type, without QZ) attached.  
<sup>3</sup> The maximum speed is restricted by the actuator's permissible speed.  
<sup>4</sup> The mass with 2 blocks (B type) has 1.8 kg added.



Without Cover Motor Flange Size 80x80  
Motor Wrap

**Dimensions**

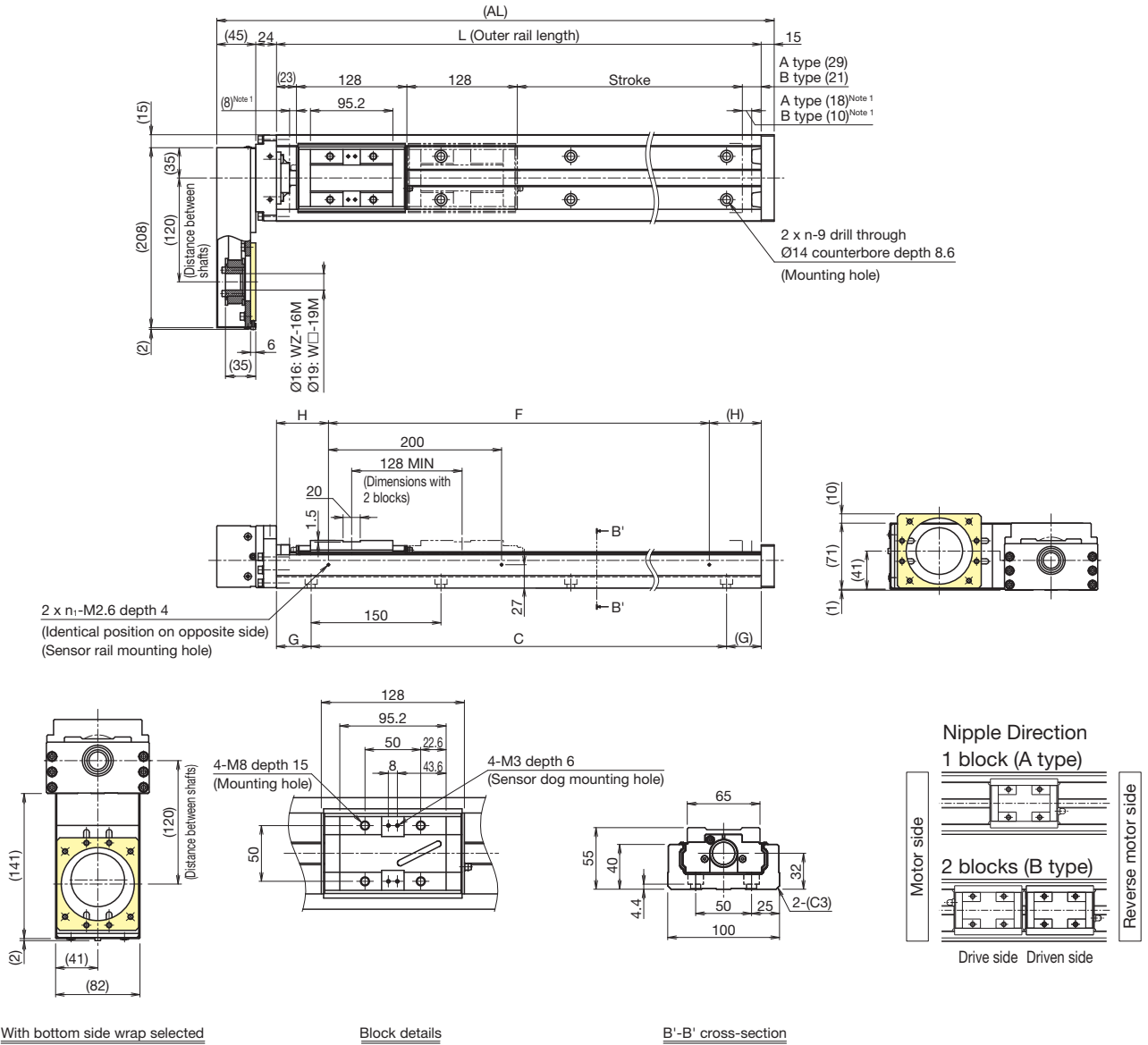

With bottom side wrap selected

Block details

B'-B' cross-section

<sup>1</sup> Dimensions from the mechanical stopper to the stroke start position.

Stroke (mm) (Stroke between mechanical stoppers)	A type	800 (826)	900 (926)	1,000 (1,026)	1,100 (1,126)	1,200 (1,226)
	B type <sup>2</sup>	680 (698)	780 (798)	880 (898)	980 (998)	1,080 (1,098)
Maximum speed <sup>3</sup> (mm/s)	Ball screw lead: 20 mm	800		740	620	530
	Precision grade	1,120	900	740	-	-
Dimensions (mm)	AL	1,064	1,164	1,264	1,364	1,464
	L	980	1,080	1,180	1,280	1,380
	C	900	1,050	1,050	1,200	1,350
	G	40	15	65	40	15
	F	800	1,000	1,000	1,200	1,200
No. of mounting holes	n	7	8	8	9	10
	n <sub>1</sub>	5	6	6	7	7
Mass <sup>4</sup> (kg)		21.1	22.8	24.5	26.3	28

<sup>2</sup> The value with 2 blocks (B type, without QZ) attached.  
<sup>3</sup> The maximum speed is restricted by the actuator's permissible speed.  
<sup>4</sup> The mass with 2 blocks (B type) has 1.8 kg added.

# Options

## Sensors

Optional photo sensors and proximity sensors are available. Sensor-equipped models also feature a dedicated sensor rail and sensor dog.

Sensors, sensor rails, and sensor dogs can be mounted on both sides when the stroke is less than 70 mm.

Mounting example

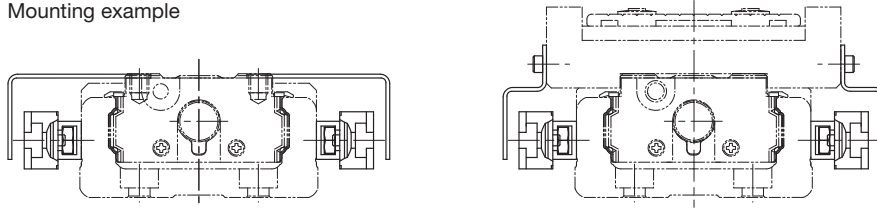

Symbol	Description	Model	Accessories
0	None	-	-
1	With sensor rail	-	Mounting screws, sensor rail (x1 or 2)
2	Photo sensor <sup>1</sup> (x3)	EE-SX671 (OMRON Corporation)	Mounting screws, nuts, sensor dog (x1 or 2), sensor rail (x1 or 2), mounting plates (x3), connectors (EE-1001 x3)
6	Photo sensor <sup>1</sup> (x3)	EE-SX674 (OMRON Corporation)	Mounting screws, nuts, sensor dog (x1 or 2), sensor rail (x1 or 2), mounting plates (x3), connectors (EE-1001 x3)
7	Proximity sensor N.O. contact <sup>2</sup> (x3)	APM-D3A1-001 (Azbil Corporation)	Mounting screws, nuts, sensor dog (x1 or 2), sensor rail (x1 or 2)
B	Proximity sensor N.C. contact <sup>3</sup> (x3)	APM-D3B1-003 (Azbil Corporation)	Mounting screws, nuts, sensor dog (x1 or 2), sensor rail (x1 or 2)
E	Proximity sensor N.O. contact <sup>2</sup> (x1) N.C. contact <sup>3</sup> (x2)	APM-D3A1-001 (Azbil Corporation) APM-D3B1-003 (Azbil Corporation)	Mounting screws, nuts, sensor dog (x1 or 2), sensor rail (x1 or 2)
H	Proximity sensor N.O. contact <sup>2</sup> (x3)	GX-F12A (Panasonic Industry Co., Ltd.)	Mounting screws, nuts, sensor dog (x1 or 2), sensor rail (x1 or 2)
L	Proximity sensor N.C. contact <sup>3</sup> (x3)	GX-F12B (Panasonic Industry Co., Ltd.)	Mounting screws, nuts, sensor dog (x1 or 2), sensor rail (x1 or 2)
J	Proximity sensor N.O. contact <sup>2</sup> (x1) N.C. contact <sup>3</sup> (x2)	GX-F12A (Panasonic Industry Co., Ltd.) GX-F12B (Panasonic Industry Co., Ltd.)	Mounting screws, nuts, sensor dog (x1 or 2), sensor rail (x1 or 2)
M	Proximity sensor N.O. contact <sup>2</sup> (x1) (PNP output) N.C. contact <sup>3</sup> (x2) (PNP output)	GX-F12A-P (Panasonic Industry Co., Ltd.) GX-F12B-P (Panasonic Industry Co., Ltd.)	Mounting screws, nuts, sensor dog (x1 or 2), sensor rail (x1 or 2)

<sup>1</sup> The photo sensors can be switched between ON when lit and ON when unlit.

<sup>2</sup> N.O. contact: Normally open contact point

<sup>3</sup> N.C. contact: Normally closed contact point

Notes: 1. If proximity sensors are close to one another, they may not function properly. If that happens, please prepare a type with a different frequency.

2. Mounting of sensors other than those in the table above is possible. Contact THK for details.

## Sensor Rail Mounting Dimensions

Mounting only a sensor rail is also possible.

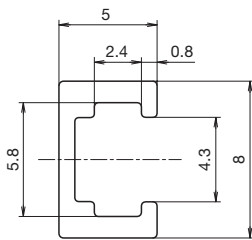

Sensor rail details

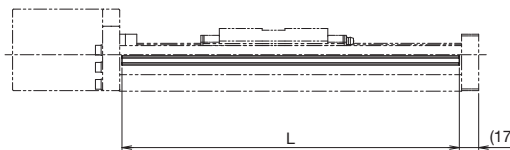

Stroke <sup>4</sup> (mm)	Outer rail length (mm)	L (mm)
800	980	976
900	1,080	1,076
1,000	1,180	1,176
1,100	1,280	1,276
1,200	1,380	1,376

<sup>4</sup> Stroke with 1 block (A type).

### Photo Sensor Mounting Dimensions

Connector: EE-1001 (OMRON Corporation) x3 included.  
To be mounted by the customer.

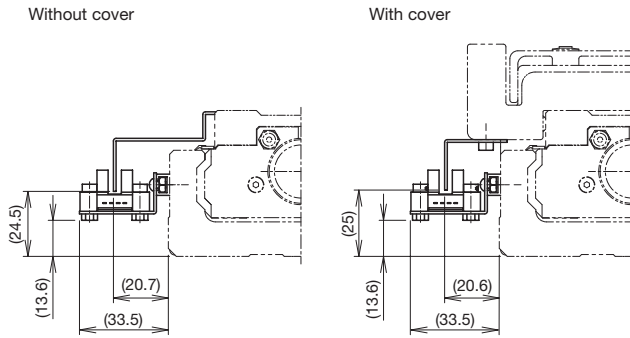

Symbol	Model	Manufacturer
2	EE-SX671	OMRON Corporation

Sensor dog width: 20 mm

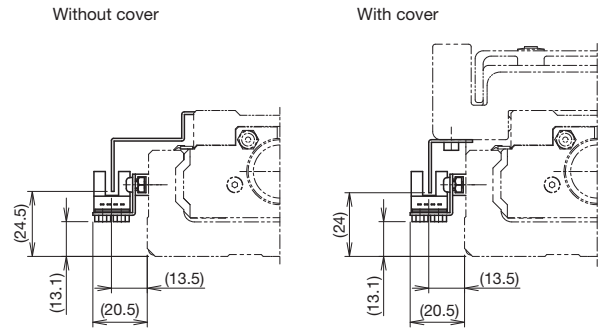

Symbol	Model	Manufacturer
6	EE-SX674	OMRON Corporation

Sensor dog width: 20 mm

### Proximity Sensor Mounting Dimensions

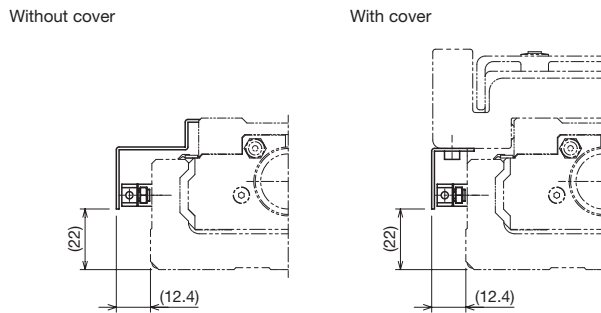

Symbol	Model	Manufacturer
7, B, E	APM-D3A1-001	Azbil Corporation
	APM-D3B1-003	

Sensor dog width: 20 mm

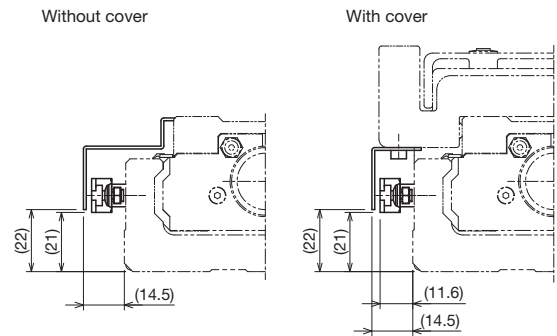

Symbol	Model	Manufacturer
H, L, J	GX-F12A	Panasonic Industry Co., Ltd.
	GX-F12B	
M	GX-F12A-P	
	GX-F12B-P	

Sensor dog width: 20 mm

# Options

## Intermediate Flange (Direct Coupling)

Several types of intermediate flanges for mounting motors are available.

When selecting "0" or "1" for Model Number Coding ⑦ With/without motor, specify an intermediate flange that matches the motor used.

Compatibility Table: Motors Used, Intermediate Flanges, and Couplings

Motor type	Manufacturer	Series	Motor model	Motor rated output (W)	Flange size	Housing A/ Intermediate flange	Compatible coupling models			
							MIKI PULLEY CO., LTD.	Nabeya Bi-tech Kaisha (NBK)		
AC servo motor	YASKAWA Electric Corporation	Σ-V	SGMJV-02	200	60×60	A0	SFC-030DA2-12B-14B	XGT2-27C-12-14		
			SGMAV-02							
			SGMJV-04	400		A0	SFC-035DA2-12B-14B	XGT2-30C-12-14		
			SGMAV-04							
			SGMJV-06	600		A0	SFC-035DA2-12B-14B	XGT2-34C-12-14		
			SGMJV-08							
		SGMAV-08	750	80×80	AZ	SFC-040DA2-12B-19B	XGT2-39C-12-19			
		SGMAV-08								
		Σ-7	SGM7J-02	200	60×60	A0	SFC-030DA2-12B-14B	XGT2-27C-12-14		
			SGM7A-02							
			SGM7J-04	400		A0	SFC-035DA2-12B-14B	XGT2-30C-12-14		
			SGM7A-04							
			SGM7J-06	600		A0	SFC-035DA2-12B-14B	XGT2-34C-12-14		
			SGM7J-08							
		SGM7A-08	750	80×80	AZ	SFC-040DA2-12B-19B	XGT2-39C-12-19			
		SGM7A-08								
		Σ-X	SGMXJ-02	200	60×60	A0	SFC-030DA2-12B-14B	XGT2-27C-12-14		
			SGMXA-02							
			SGMXJ-04	400		A0	SFC-035DA2-12B-14B	XGT2-30C-12-14		
			SGMXA-04							
			SGMXJ-06	600		A0	SFC-035DA2-12B-14B	XGT2-34C-12-14		
			SGMXA-06							
			SGMXJ-08	750		80×80	AZ	SFC-040DA2-12B-19B	XGT2-39C-12-19	
			SGMXA-08							
	Mitsubishi Electric Corporation	MELSERVO	J4	HG-KR23	200	60×60	A0	SFC-030DA2-12B-14B	XGT2-27C-12-14	
				HG-MR23						
				HG-KR43	400		A0	SFC-035DA2-12B-14B	XGT2-30C-12-14	
				HG-MR43						
			HG-KR73	750	80×80		AZ	SFC-040DA2-12B-19B	XGT2-39C-12-19	
			HG-MR73							
		J5	HK-KT23W	200	60×60	A0	SFC-030DA2-12B-14B	XGT2-27C-12-14		
			HK-KT43W	400	60×60	A0	SFC-035DA2-12B-14B	XGT2-30C-12-14		
		JN	HK-KT7M3W	750	80×80	AZ	SFC-040DA2-12B-19B	XGT2-39C-12-19		
			HF-KN23	200	60×60	A0	SFC-030DA2-12B-14B	XGT2-27C-12-14		
		TAMAGAWA SEIKI CO., LTD.	TBL-iii	TS4607	TS4607	200	60×60	A0	SFC-030DA2-12B-14B	XGT2-27C-12-14
					TS4609	400			SFC-035DA2-12B-14B	XGT2-30C-12-14
	TS4614				750	80×80			AZ	SFC-040DA2-12B-19B
	TBL-iiV			TSM3202	200	60×60		A0	SFC-030DA2-12B-14B	XGT2-27C-12-14
				TSM3204	400	60×60		A0	SFC-035DA2-12B-14B	XGT2-30C-12-14
				TSM3303	600	80×80		AZ	SFC-040DA2-12B-19B	XGT2-39C-12-19
Panasonic Corporation	MINAS		A5	MSMD08	750	80×80	A5	SFC-040DA2-12B-19B	XGT2-39C-12-19	
				MSME08						
				MSMF08	750			80×80	A5	SFC-040DA2-12B-19B
MHMF08										
KEYENCE CORPORATION	SV		SV	SV-M020	200	60×60	A0	SFC-030DA2-12B-14B	XGT2-27C-12-14	
				SV-M040	400			SFC-035DA2-12B-14B	XGT2-30C-12-14	
		SV-M075		750	80×80			AZ	SFC-040DA2-12B-19B	XGT2-39C-12-19
	SV2	SV2	SV2-M020	200	60×60	A0	SFC-030DA2-12B-14B	XGT2-27C-12-14		
			SV2-M040	400	60×60	A0	SFC-035DA2-12B-14B	XGT2-30C-12-14		
			SV2-M075	750	80×80	AZ	SFC-040DA2-12B-19B	XGT2-39C-12-19		
SANYO DENKI CO., LTD.	SANMOTION R	R2□A06020	R2□A06020	200	60×60	A0	SFC-030DA2-12B-14B	XGT2-27C-12-14		
			R2AA06040	400			SFC-035DA2-12B-14B	XGT2-30C-12-14		
			R2AA08075	750			80×80	AZ	SFC-040DA2-12B-16B	XGT2-39C-12-16
OMRON Corporation	OMNUC G5	1S	R88M-K75030	750	80×80	A5	SFC-040DA2-12B-19B	XGT2-39C-12-19		
			R88M-1M75030	750	80×80					

Motor type	Manufacturer	Series	Motor model	Flange size	Housing A/ Intermediate flange	Compatible coupling models		
						MIKI PULLEY CO., LTD.	Nabeya Bi-tech Kaisha (NBK)	
Stepper motor	ORIENTAL MOTOR CO., LTD.	α step		AZ9*, AR9*	85×85	A6	SFC-035DA2-12B-14B	XGT2-34C-12-14
		5-phase	RK II	RKS59*	85×85	A6	SFC-035DA2-12B-14B	XGT2-34C-12-14

Notes: 1. The table shows only a portion of the model numbers for motors. For details regarding model numbers, please see the catalog for each respective motor manufacturer.  
 2. If the maximum torque for motors exceeds the permissible input torque (p. 131), please consider a safety measure to limit the torque.  
 3. When installing a motor other than the motor model numbers listed above, contact THK.

Housing A

KR55
A0

KR**	Actuator model
●◇	●: Housing A ◇: Intermediate flange

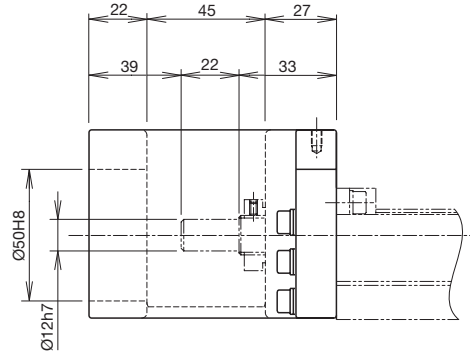
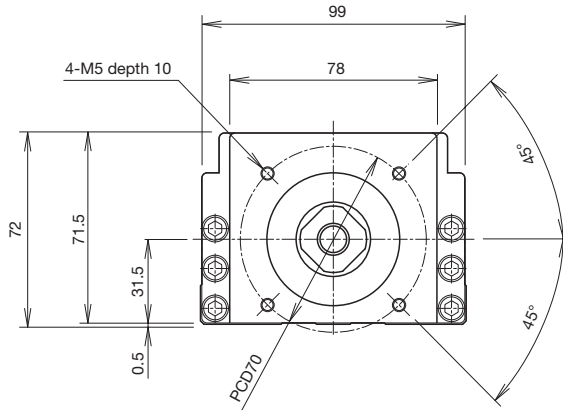

Intermediate Flange

KR55
A5

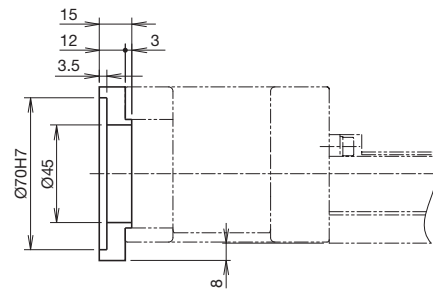
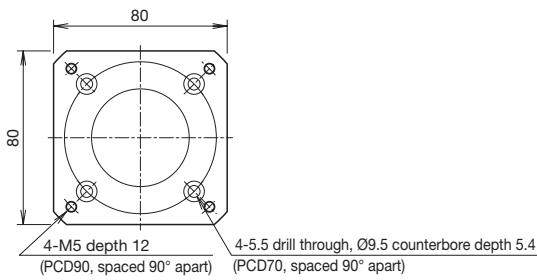

KR55
AZ

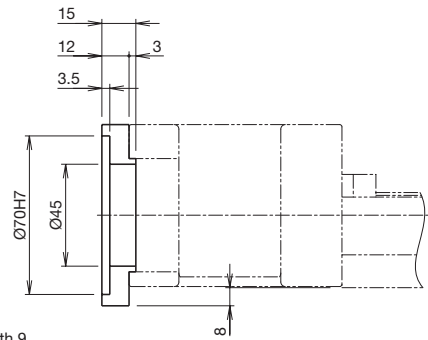
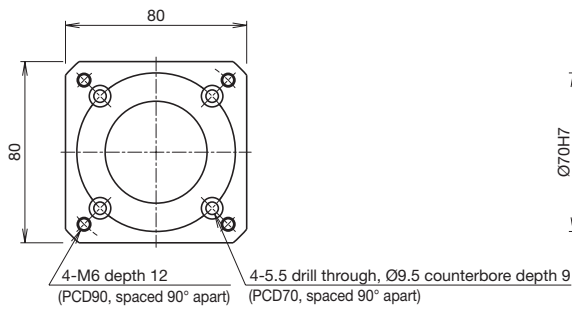

KR55
A6

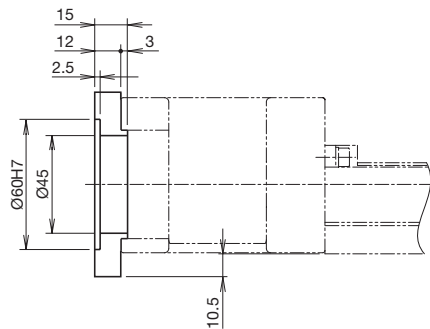
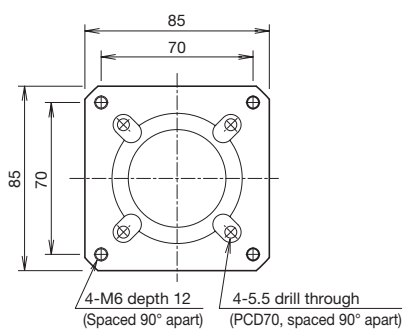

# Options

## Intermediate Flange (Motor Wrap)

Several types of intermediate flanges for mounting motors are available.

When selecting "R1," "R2," "R3," "R4," "R5," or "R6" for Model Number Coding ⑦ With/without motor, specify an intermediate flange that matches the motor used.

Symbol Coding

Motor wrap symbol ①	Intermediate flange ②	Motor shaft diameter (mm) ③	Motor shaft securing method ④
W	V	14	M
W	Refer to the Compatibility Table: Motors Used and Motor Wrap Symbols below.	Specify a motor shaft diameter. (Refer to the Compatibility Table: Motors Used and Motor Wrap Symbols below.)	M: Friction tightening tool

Motor Shaft Securing Method

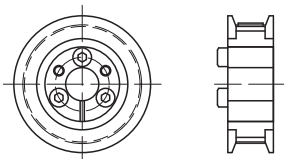

Friction tightening tool

Compatibility Table: Motors Used and Motor Wrap Symbols

Motor type	Manufacturer	Series	Motor model	Motor rated output (W)	Flange size	Housing A/Intermediate flange					
AC servo motor	YASKAWA Electric Corporation	Σ-V	SGMJV-02	200	60×60	WV-14M					
			SGMAV-02								
			SGMJV-04	400							
			SGMAV-04								
			SGMJV-06	600							
			SGMAV-06								
		SGMJV-08	750	80×80	WZ-19M						
		SGMAV-08									
		Σ-7	SGM7J-02			200	60×60	WV-14M			
			SGM7A-02								
			SGM7J-04			400					
			SGM7A-04								
			SGM7J-06	600							
			SGM7A-06								
		SGM7J-08	750	80×80	WZ-19M						
		SGM7A-08									
		Σ-X	SGMXJ-02			200	60×60	WV-14M			
			SGMXA-02								
	SGMXJ-04		400								
	SGMXA-04										
	SGMXJ-06		600								
	SGMXA-06										
	SGMXJ-08	750	80×80	WZ-19M							
	SGM7A-08										
	Mitsubishi Electric Corporation	MELSERVO			J4	HG-KR23	200	60×60	WV-14M		
						HG-MR23					
						HG-KR43	400				
					HG-MR43						
			HG-KR73	750	80×80	WZ-19M					
			HG-MR73								
		HK-KT23W	200				60×60	WV-14M			
		HK-KT43W									
		HK-KT7M3W		750					80×80	WZ-19M	
		HF-KN23	200								60×60
		HF-KN43									
		HF-KN43		400							
	TAMAGAWA SEIKI CO., LTD.	TBL-III	TS4607		200	60×60	WV-14M				
			TS4609								
			TS4614	750	80×80			WZ-19M			
		TSM3202	200						60×60	WV-14M	
TSM3204											
TSM3303		600		80×80							WZ-19M
TSM3304	750										
Panasonic Corporation		MINAS	A5			MSMD08	750				
	MSME08										
	MSMF08										
	A6	MHMF08									
		KEYENCE CORPORATION	SV	SV-M020	200	60×60		WV-14M			
				SV-M040							
SV-M075	750			80×80	WZ-19M						
SV2-M020			200				60×60		WV-14M		
SV2-M040											
SV2-M075	750									80×80	WZ-19M
SV2-M075											
SANYO DENKI CO., LTD.		SANMOTION R	R2□A06020			200		60×60			
	R2AA06040										
	R2AA08075		750	80×80	WZ-16M						
	R2AA08075										
OMRON Corporation	OMNUC G5	R88M-K75030	750			80×80	W5-19M				
		1S R88M-1M75030									

Notes: 1. The table shows only a portion of the model numbers for motors. For details regarding model numbers, please see the catalog for each respective motor manufacturer.  
 2. If the maximum torque for motors exceeds the permissible input torque (p. 131), please consider a safety measure to limit the torque.  
 3. When installing a motor other than the motor model numbers listed above, contact THK.

### Motor Wrap Housing A

KR55
20

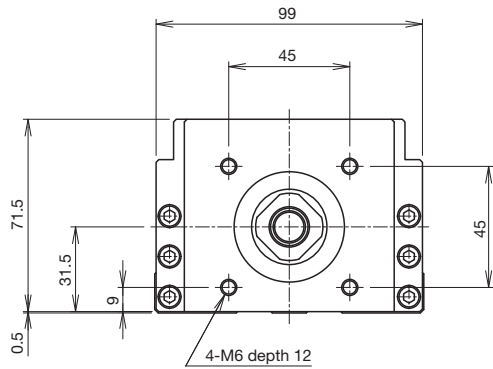

KR**	Actuator model
●◇	●: Housing A ◇: Intermediate flange

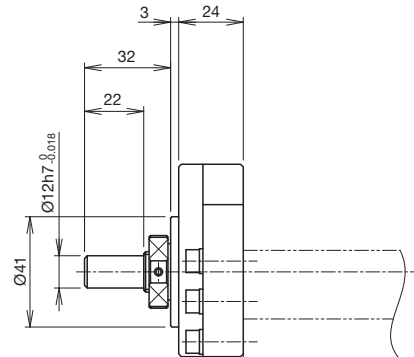

### Motor Wrap Specification (Intermediate Flange)

KR55
WV

Thickness: 6 mm

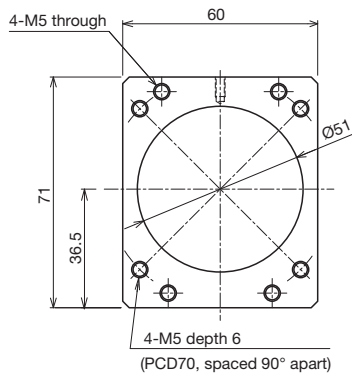

KR55
W5

Thickness: 6 mm

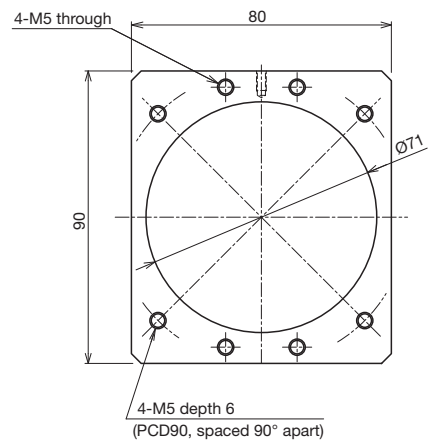

KR55
WZ

Thickness: 6 mm

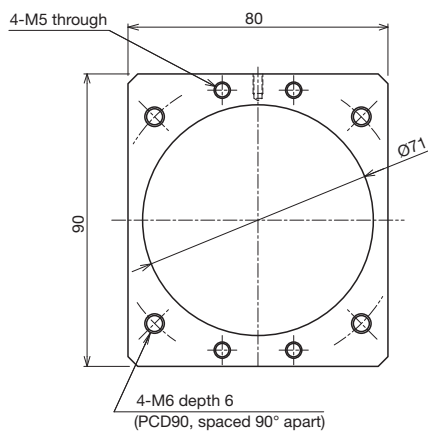

## Options

### QZ Lubricator

The QZ Lubricator for KR feeds the right amount of lubricant to the outer rail and ball screw shaft raceways. This allows an oil film to be constantly formed between the balls and the raceway, and it significantly extends the lubrication maintenance interval.

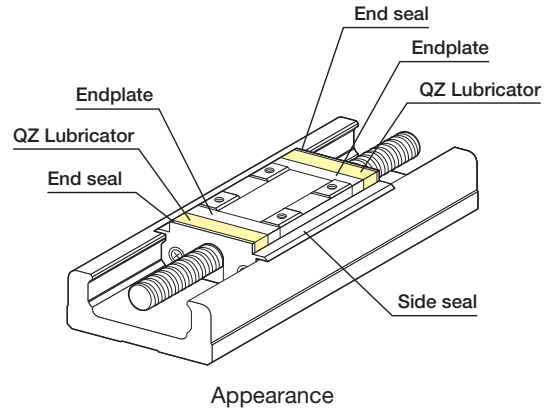

### Features

- Since it compensates for oil loss, the lubrication maintenance interval can be significantly extended.
- It is an eco-friendly lubrication system that does not contaminate the surrounding area, as it feeds the right amount of lubricant to the ball raceway.

### QZ Configuration

Symbol	Block type	Description
QZ	A/B	QZ all-block double-sided specification
QZA	A	QZ fixed side specification
QZB	A	QZ supported side specification
QZAD	B	QZ fixed side (drive side block) + QZ supported side (driven side block) specification

Note: QZ specification types do not have a grease nipple mounted. Contact THK if a grease nipple is required.

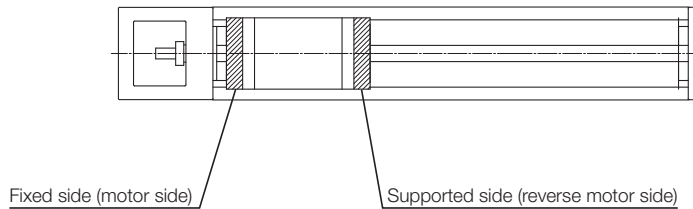

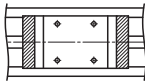
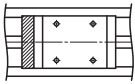
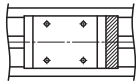
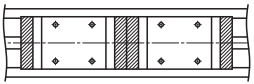
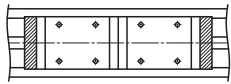
Block type	QZ configuration	QZ	QZA	QZB	QZAD
	A type (1 block)		 Fixed side	 Fixed side	 Supported side
B type (2 blocks)		 Fixed side	-	-	 Supported side

### Dimensions with QZ Lubricator

QZ (With Cover)  
Block Type: A/B

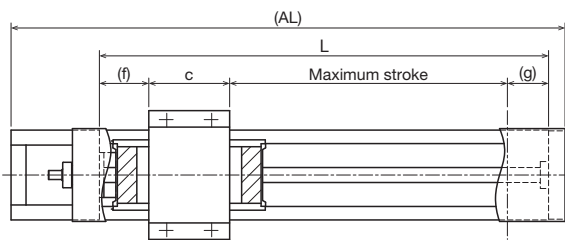

Block Type A

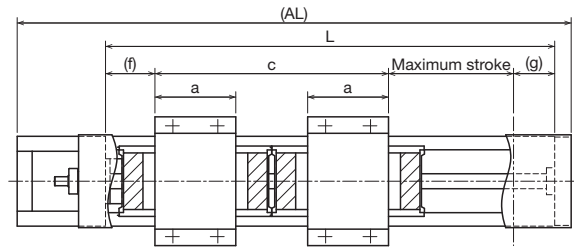

Block Type B

Unit: mm

Block type	Overall length AL	Outer rail length L	Stroke <sup>1</sup>	Maximum stroke <sup>1</sup>	a	c	f	g
A	1,089	980	770	794	-	95.2	47.4	43.4
	1,189	1,080	870	894				
	1,289	1,180	970	994				
	1,389	1,280	1,070	1,094				
	1,489	1,380	1,170	1,194				
B	1,089	980	615	634	95.2	255.2	47.4	43.4
	1,189	1,080	715	734				
	1,289	1,180	815	834				
	1,389	1,280	915	934				
	1,489	1,380	1,015	1,034				

<sup>1</sup> The value for B block types is with 2 blocks attached.

QZ (Without Cover)  
Block Type: A/B

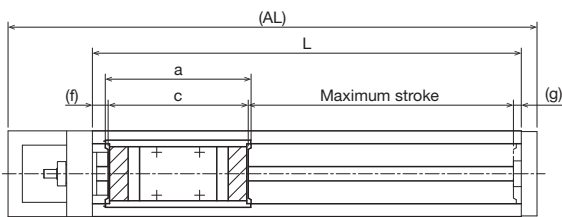

Block Type A

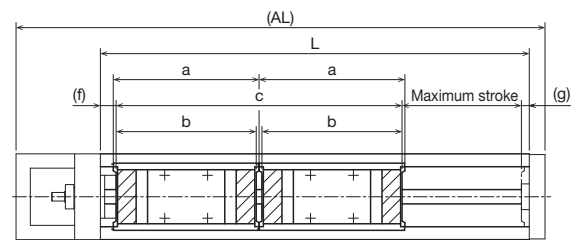

Block Type B

Unit: mm

Block type	Overall length AL	Outer rail length L	Stroke <sup>2</sup>	Maximum stroke <sup>2</sup>	a	b	c	f	g
A	1,089	980	770	794	160	-	160	15	11
	1,189	1,080	870	894					
	1,289	1,180	970	994					
	1,389	1,280	1,070	1,094					
	1,489	1,380	1,170	1,194					
B	1,089	980	615	634	160	160	320	15	11
	1,189	1,080	715	734					
	1,289	1,180	815	834					
	1,389	1,280	915	934					
	1,489	1,380	1,015	1,034					

<sup>2</sup> The value for B block types is with 2 blocks attached.

# Options

## Dimensions with QZ Lubricator

**QZA (With Cover)**  
Block Type: A

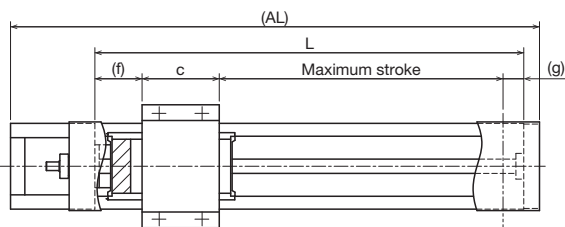

Block Type A

**QZA (Without Cover)**  
Block Type: A

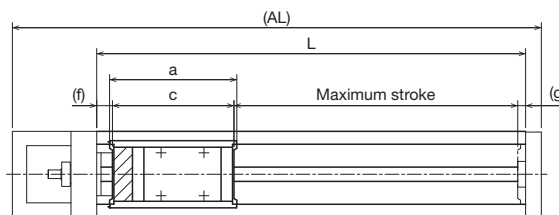

Block Type A

**QZA (With Cover)**

Unit: mm

Block type	Overall length AL	Outer rail length L	Stroke	Maximum stroke	c	f	g
A	1,089	980	785	810	95.2	47.4	27.4
	1,189	1,080	885	910			
	1,289	1,180	985	1,010			
	1,389	1,280	1,085	1,110			
	1,489	1,380	1,185	1,210			

Note 1: B block types cannot be selected for QZA.

**QZA (Without Cover)**

Unit: mm

Block type	Overall length AL	Outer rail length L	Stroke	Maximum stroke	a	c	f	g
A	1,089	980	785	810	144	144	15	11
	1,189	1,080	885	910				
	1,289	1,180	985	1,010				
	1,389	1,280	1,085	1,110				
	1,489	1,380	1,185	1,210				

Note 2: B block types cannot be selected for QZA.

**QZB (With Cover)**  
Block Type: A

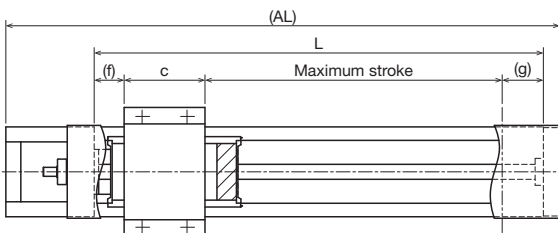

Block Type A

**QZB (Without Cover)**  
Block Type: A

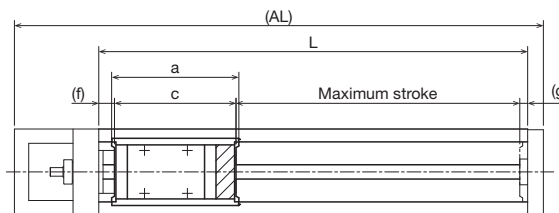

Block Type A

**QZB (With Cover)**

Unit: mm

Block type	Overall length AL	Outer rail length L	Stroke	Maximum stroke	c	f	g
A	1,089	980	785	810	95.2	31.4	43.4
	1,189	1,080	885	910			
	1,289	1,180	985	1,010			
	1,389	1,280	1,085	1,110			
	1,489	1,380	1,185	1,210			

Note 3: B block types cannot be selected for QZB.

**QZB (Without Cover)**

Unit: mm

Block type	Overall length AL	Outer rail length L	Stroke	Maximum stroke	a	c	f	g
A	1,089	980	785	810	144	144	15	11
	1,189	1,080	885	910				
	1,289	1,180	985	1,010				
	1,389	1,280	1,085	1,110				
	1,489	1,380	1,185	1,210				

Note 4: B block types cannot be selected for QZB.

### Dimensions with QZ Lubricator

#### QZAD (With Cover) Block Type: B

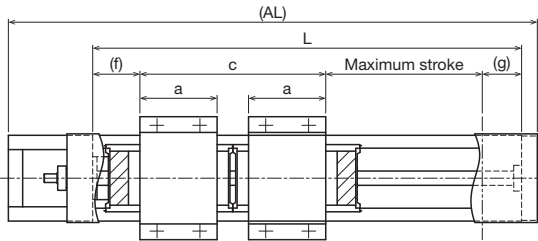

Block Type B

#### QZAD (Without Cover) Block Type: B

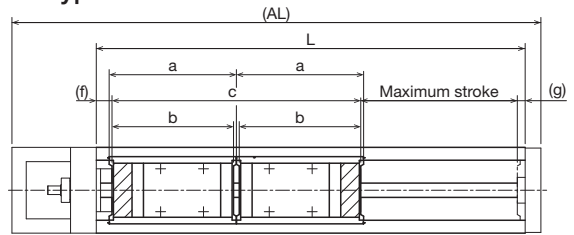

Block Type B

#### QZAD (With Cover)

Unit: mm

Block type	Overall length AL	Outer rail length L	Stroke <sup>1</sup>	Maximum stroke <sup>1</sup>	a	c	f	g
B	1,089	980	650	666	95.2	223.2	47.4	43.4
	1,189	1,080	750	766				
	1,289	1,180	850	866				
	1,389	1,280	950	966				
	1,489	1,380	1,050	1,066				

<sup>1</sup> The value for B block types is with 2 blocks attached.

Note 1: A block types cannot be selected for QZAD.

#### QZAD (Without Cover)

Unit: mm

Block type	Overall length AL	Outer rail length L	Stroke <sup>2</sup>	Maximum stroke <sup>2</sup>	a	b	c	f	g
B	1,089	980	650	666	144	144	288	15	11
	1,189	1,080	750	766					
	1,289	1,180	850	866					
	1,389	1,280	950	966					
	1,489	1,380	1,050	1,066					

<sup>2</sup> The value for B block types is with 2 blocks attached.

Note 2: A block types cannot be selected for QZAD.

# KR65 A/B

Direct motor coupling

Motor wrap

Width 130 mm

Height 65 mm

Max. stroke 1,490 mm

## Model Number Coding

Model	Ball screw lead	Block type	QZ specification	Stroke	Accuracy grade	With/without motor	Cover	Sensors	Housing A/ Intermediate flange
①	②	③	④	⑤	⑥	⑦	⑧	⑨	⑩
KR65	25	A	QZA	0775	P	0	1	2	AZ
<b>KR65</b>	<b>25: 25 mm</b>	<b>A: x1</b> <b>B: x2</b>	<b>No symbol: Without QZ</b> <b>QZ</b> <b>QZA</b> <b>QZB</b> <b>QZAD</b>	<b>0640: 640 mm</b> to <b>1490: 1,490 mm</b> <small>When selecting 2: With bellows for ⑧ Cover, specify the stroke with bellows. → p. 165 to p. 166</small>	<b>No symbol: Normal grade</b> <b>H: High accuracy grade</b> <b>P: Precision grade</b>	<b>With direct coupling</b> <b>0: Direct coupling (without motor)</b> <b>1: Direct coupling (THK will purchase and mount the motor you specify.)</b> <b>With motor wrap</b> <b>R1: Non-standard side wrap (without motor)</b> <b>R2: Standard side wrap (without motor)</b> <b>R3: Bottom side wrap (without motor)</b> <b>R4: Non-standard side wrap (THK will purchase and mount the motor you specify.)</b> <b>R5: Standard side wrap (THK will purchase and mount the motor you specify.)</b> <b>R6: Bottom side wrap (THK will purchase and mount the motor you specify.)</b> <small>When selecting "0": A coupling is not provided. Indicate when placing an order if a coupling is required. When selecting "1," "R4," "R5," or "R6": The specified motor will be installed. Indicate the motor cable direction separately. Select ⑩ Intermediate flange to match the specified motor.</small>	<b>0: Without cover</b> <b>1: With cover</b> <b>2: With bellows</b>	<b>0</b> <b>1</b> <b>2</b> <b>6</b> <b>7</b> <b>B</b> <b>E</b> <b>H</b> <b>L</b> <b>J</b> <b>M</b> <small>Sensor details → p. 155</small> <b>W5-19M</b>	<b>With direct coupling</b> <b>A0</b> <b>AV</b> <b>AZ</b> <b>A5</b> <b>A6</b> <b>30</b> <b>With motor wrap</b> <b>WV-14M</b> <b>WZ-16M</b> <b>WZ-19M</b> <small>With direct coupling → p. 157 With motor wrap → p. 159</small>

### ③ Block Type

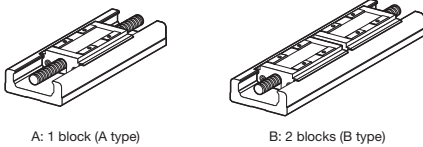

### ⑦ Motor Mounting Method

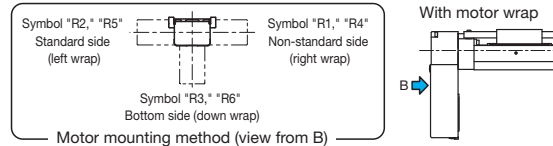

## Selection Information

### Basic Specifications

LM Guide	Basic dynamic load rating C (N)		65,100
	Basic static load rating C <sub>0</sub> (N)		91,700
	Radial clearance (mm)	Normal grade/High accuracy grade (H)	-0.008 to +0.004
		Precision grade (P)	-0.022 to -0.008
Geometric moment of inertia	I <sub>x</sub> <sup>1</sup> (mm <sup>4</sup> )	4.6×10 <sup>5</sup>	
	I <sub>y</sub> <sup>2</sup> (mm <sup>4</sup> )	5.9×10 <sup>5</sup>	
	Mass (kg/m)	23.1	
Ball screw	Ball screw lead (mm)		25
	Basic dynamic load rating Ca (N)	Normal grade/High accuracy grade (H)	5,680
		Precision grade (P)	5,950
	Basic static load rating C <sub>0a</sub> (N)	Normal grade/High accuracy grade (H)	14,500
		Precision grade (P)	10,700
	Screw shaft diameter (mm)		Ø25
	Thread minor diameter (mm)		Ø22
	Ball center-to-center diameter (mm)		Ø26
Permissible rotational speed <sup>3</sup> (min <sup>-1</sup> )	Normal grade/High accuracy grade (H)	1,920	
	Precision grade (P)	2,690	
Bearing unit (fixed side)	Axial direction	Basic dynamic load rating Ca (N)	13,700
		Static permissible load P <sub>0a</sub> (N)	5,830
Permissible input torque (N·m)	Direct coupling		18.5
	Motor wrap <sup>4</sup>		7.2 (6.7)
Static permissible moment <sup>5,6</sup> (N·m)		M <sub>x</sub> : 1,300 (7,230), M <sub>y</sub> : 1,300 (7,230), M <sub>z</sub> : 3,920 (7,840)	
Service life <sup>7</sup> (km)		10,000	
Standard grease/Grease nipple used		THK AFB-LF Grease/A-M6F	

- <sup>1</sup> I<sub>x</sub> is the geometric moment of inertia about the X axis.  
<sup>2</sup> I<sub>y</sub> is the geometric moment of inertia about the Y axis.  
<sup>3</sup> The permissible rotational speed may decrease as the stroke becomes longer.  
<sup>4</sup> The values in parentheses are for precision grade.  
<sup>5</sup> The value in parentheses is with 2 blocks (B type) attached.  
<sup>6</sup> See p. 172 for the values if "1" or "2" is selected for item ③ in the Model Number Coding.  
<sup>7</sup> Calculated under the following conditions.  
 Stroke: 1,190 mm (A type), 1,040 mm (B type) / Speed: 800 mm/s (for 25 mm lead) / Load mass: Maximum load capacity (p. 9) / Acceleration/deceleration: As when set to maximum load capacity (p. 9) / Center of gravity: Center of the table's upper surface.  
 Notes: 1. LM Guide load rating is the load rating per block.  
 2. Precision grade (P-grade) ball screws have integrated spacer balls with a 2:1 ratio.

### Geometric Moment of Inertia

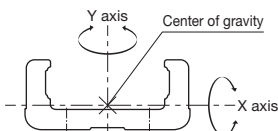

### Static Permissible Moment

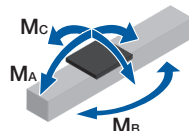

### Accuracy

Accuracy grade	Item	Stroke <sup>8</sup>			
		790	990	1,190	1,490
Normal grade (no symbol)	Positioning repeatability (mm)	±0.01			±0.012
	Positioning accuracy (mm)	Not specified			
	Running parallelism (vertical direction) (mm)	Not specified			
	Backlash (mm)	0.05			
	Starting torque (N·cm)	12			15

Accuracy grade	Item	Stroke <sup>8</sup>			
		790	990	1,190	1,490
High accuracy grade (H)	Positioning repeatability (mm)	±0.008			
	Positioning accuracy (mm)	0.18	0.2	0.28	
	Running parallelism (vertical direction) (mm)	0.05		0.055	
	Backlash (mm)	0.05			
	Starting torque (N·cm)	12			15

Accuracy grade	Item	Stroke <sup>8</sup>		
		790	990	1,190
Precision grade (P)	Positioning repeatability (mm)	±0.005		
	Positioning accuracy (mm)	0.035	0.04	
	Running parallelism (vertical direction) (mm)	0.025	0.03	
	Backlash (mm)	0.005		
	Starting torque (N·cm)	20	22	

- <sup>8</sup> Stroke with 1 block (A type, without QZ).  
 Notes: 3. Precision evaluation in accordance with THK standards.  
 4. Measured using a motor for inspection. With motor wrap specifications, measurements are not made in the completed motor wrap state.  
 5. The starting torque represents the value when containing THK AFB-LF Grease.  
 6. The starting torque may exceed standards if using vacuum grease, clean room grease, or other high-viscosity greases, so care should be taken when selecting a motor.  
 7. Contact THK for accuracy higher than the standard stroke.

### Motor Selection Information

Stroke <sup>1</sup> (mm)	Outer rail length (mm)	LM Guide				Ball screw		Motor mounting part	
		Moving part mass (kg)			Sliding resistance value <sup>2</sup> (N)	Lead (mm)	Shaft length (mm)	Direct coupling	Motor wrap
		Block mass	Sub-table mass	Total mass				Shaft end diameter (mm)	Timing pulley (sum of two) Inertial moment x 10 <sup>-4</sup> (kg·m <sup>2</sup> )
790 to 1,490	980 to 1,680	A type: 3.3 B type: 6.6	A type: 3.3 B type: 6.6	A type: 6.6 B type: 13.2	10.1	25	1,062 to 1,762	Ø15h7	2.081

<sup>1</sup> Stroke with 1 block (A type, without QZ).

<sup>2</sup> Value with 1 block (A type, without QZ). This value is the sum of the rolling resistance value and seal resistance value.

Note: Refer to p. 157 for applicable couplings.

### Permissible Overhang Length<sup>3</sup>

Horizontal

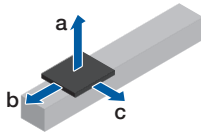

Wall-Mounted

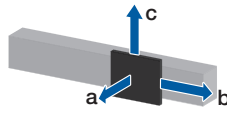

Vertical

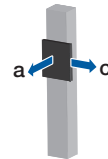

Estimated motor capacity 750 W		Ball screw lead (mm)	Load mass (kg)	a (mm)	b (mm)	c (mm)
Direct coupling	A type	25	15	1,300	430	830
			30.5	660	210	400
			61	300	100	200
	B type	25	13.5	1,300	1,300	1,300
			27	1,300	1,300	920
			54.5	1,300	690	450
Motor wrap	A type	25	9.5	1,300	680	1,300
			19.5	1,060	330	640
			39.5	490	160	310
	B type	25	10.5	1,300	1,300	1,300
			21.5	1,300	1,300	1,160
			43.5	1,300	860	570

Estimated motor capacity 750 W		Ball screw lead (mm)	Load mass (kg)	a (mm)	b (mm)	c (mm)
Direct coupling	A type	25	15	770	590	1,300
			30.5	340	280	1,280
			61	140	120	640
	B type	25	13.5	1,300	1,300	1,300
			27	860	1,190	1,300
			54.5	390	590	1,300
Motor wrap	A type	25	9.5	1,260	940	1,300
			19.5	570	450	1,300
			39.5	250	210	980
	B type	25	10.5	1,300	1,300	1,300
			21.5	1,100	1,300	1,300
			43.5	510	740	1,300

Estimated motor capacity 750 W		Ball screw lead (mm)	Load mass (kg)	a (mm)	c (mm)
Direct coupling	A type	25	6	780	1,300
			12	360	710
			24	150	330
	B type	25	5	1,300	1,300
			10.5	1,300	1,300
			21	1,300	1,180
Motor wrap	A type	25	4	1,200	1,300
			8	570	1,060
			16.5	250	500
	B type	25	3.5	1,300	1,300
			7.5	1,300	1,300
			15.5	1,300	1,300

<sup>3</sup> This is the value with the service life of the LM Guide limited to 10,000 km. The calculation conditions are as follows.

Stroke: 1,140 mm (A type), 990 mm (B type) / Acceleration/deceleration: 0.3 G / Speed: 800 mm/s (for 25 mm lead) / Overhang direction: Loaded only in a single direction. Dimensions a, b, and c are from the center of the table's upper surface.

With Cover  
Direct Motor Coupling

Dimensions

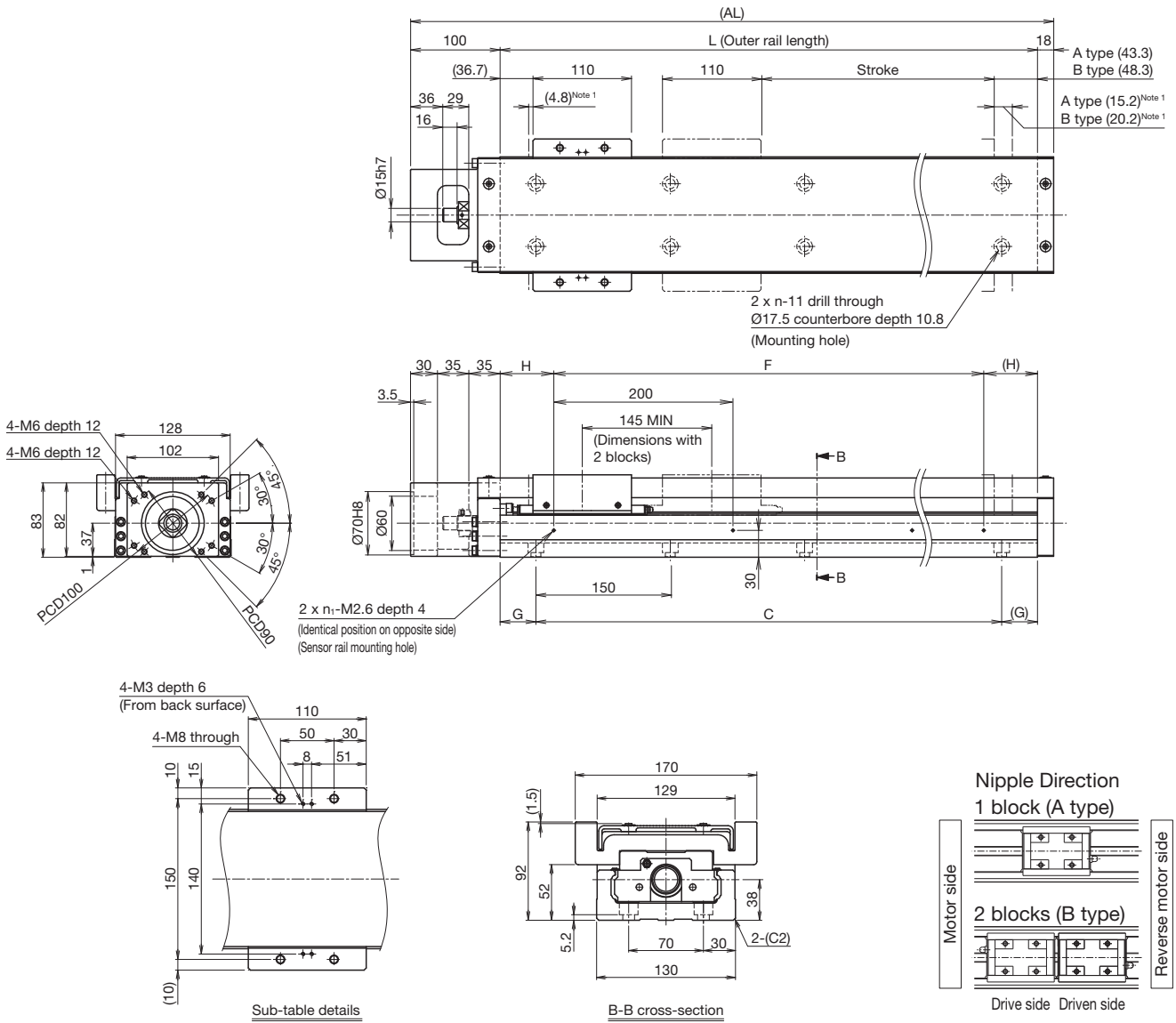

<sup>1</sup> Dimensions from the mechanical stopper to the stroke start position.

Stroke (mm) (Stroke between mechanical stoppers)	A type		790 (810)	990 (1,010)	1,190 (1,210)	1,490 (1,510)
	B type <sup>2</sup>		640 (665)	840 (865)	1,040 (1,065)	1,340 (1,365)
Maximum speed <sup>3</sup> (mm/s)	Ball screw lead: 25 mm	Normal grade/high accuracy grade	800			550
		Precision grade	1,120			-
Dimensions (mm)	AL	1,098	1,298	1,498	1,798	
	L	980	1,180	1,380	1,680	
	C	900	1,050	1,200	1,500	
	G	40	65	90	90	
	F	800	1,000	1,200	1,600	
	H	90	90	90	40	
No. of mounting holes	n	7	8	9	11	
	n <sub>1</sub>	5	6	7	9	
Mass <sup>4</sup> (kg)		38.6	44.3	50	58.5	

<sup>2</sup> The value with 2 blocks (B type, without QZ) attached.  
<sup>3</sup> The maximum speed is restricted by the actuator's permissible speed.  
<sup>4</sup> The mass with 2 blocks (B type) has 6.6 kg added.

Without Cover  
Direct Motor Coupling

**Dimensions**

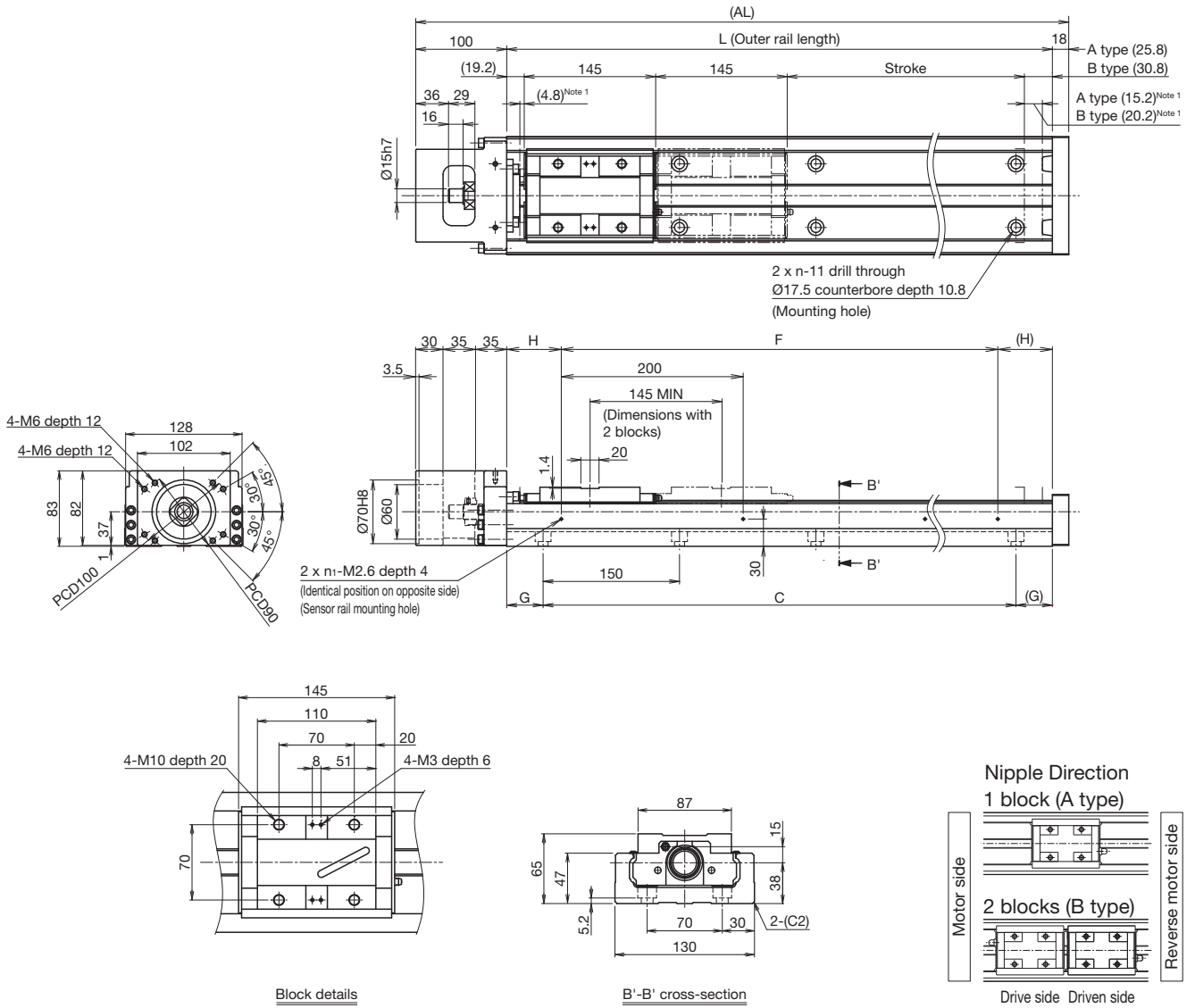

<sup>1</sup> Dimensions from the mechanical stopper to the stroke start position.

Stroke (mm) (Stroke between mechanical stoppers)	A type		790 (810)	990 (1,010)	1,190 (1,210)	1,490 (1,510)
	B type <sup>2</sup>		640 (665)	840 (865)	1,040 (1,065)	1,340 (1,365)
Maximum speed <sup>3</sup> (mm/s)	Ball screw lead: 25 mm	Normal grade/high accuracy grade	800			550
		Precision grade	1,120			-
Dimensions (mm)	AL		1,098	1,298	1,498	1,798
	L		980	1,180	1,380	1,680
	C		900	1,050	1,200	1,500
	G		40	65	90	90
	F		800	1,000	1,200	1,600
	H		90	90	90	40
No. of mounting holes	n		7	8	9	11
	n <sub>1</sub>		5	6	7	9
Mass <sup>4</sup> (kg)			32.2	37.6	43	51.1

<sup>2</sup> The value with 2 blocks (B type, without QZ) attached.

<sup>3</sup> The maximum speed is restricted by the actuator's permissible speed.

<sup>4</sup> The mass with 2 blocks (B type) has 3.3 kg added.

With Cover  
Motor Wrap

Dimensions

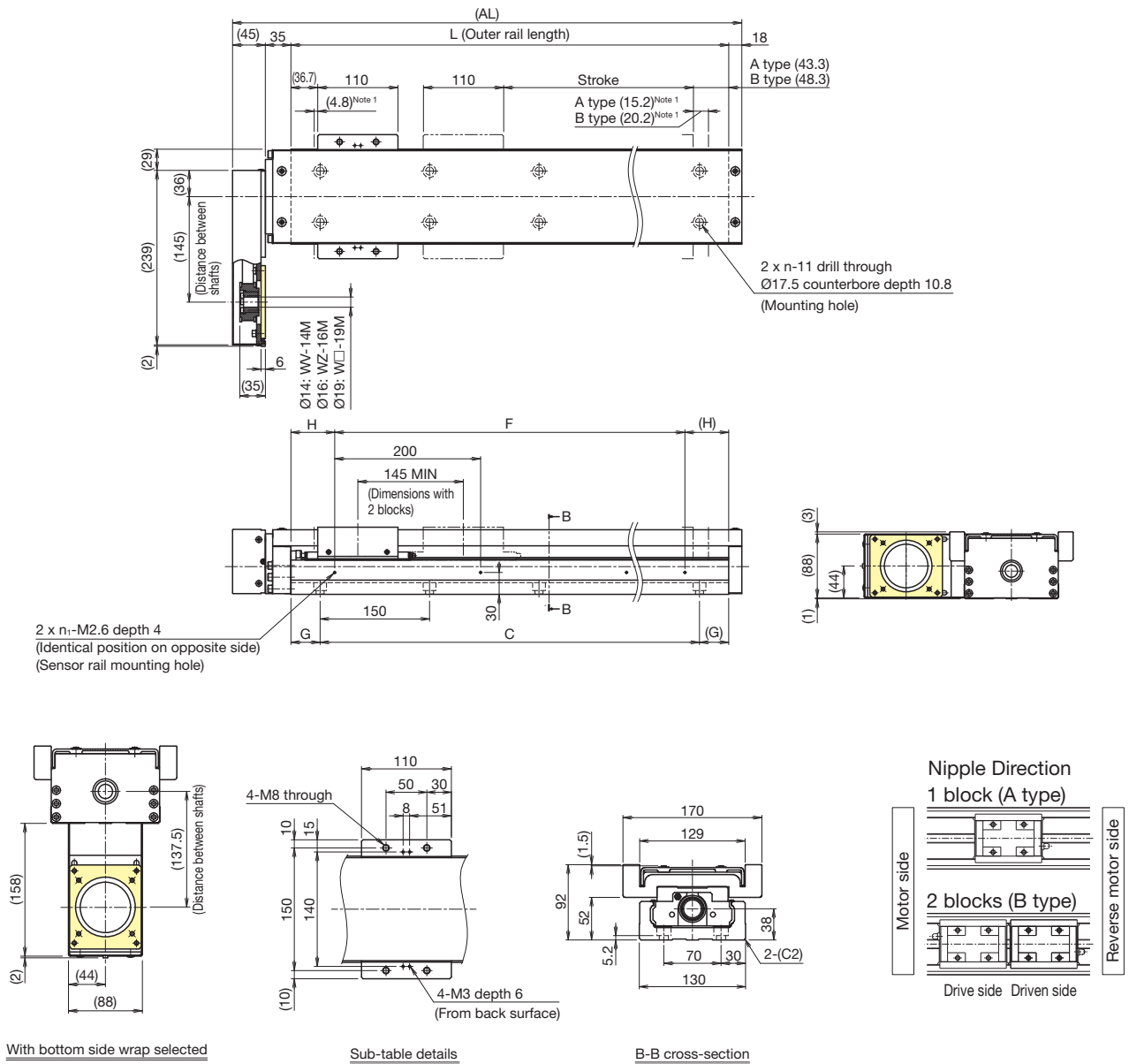

<sup>1</sup> Dimensions from the mechanical stopper to the stroke start position.

Stroke (mm) (Stroke between mechanical stoppers)	A type	790 (810)	990 (1,010)	1,190 (1,210)	1,490 (1,510)
	B type <sup>2</sup>	640 (665)	840 (865)	1,040 (1,065)	1,340 (1,365)
Maximum speed <sup>3</sup> (mm/s)	Ball screw lead: 25 mm	800		840	550
	Normal grade/high accuracy grade	1,120			
Dimensions (mm)	AL	1,078	1,278	1,478	1,778
	L	980	1,180	1,380	1,680
	C	900	1,050	1,200	1,500
	G	40	65	90	90
	F	800	1,000	1,200	1,600
	H	90	90	90	40
No. of mounting holes	n	7	8	9	11
	n <sub>1</sub>	5	6	7	9
Mass <sup>4</sup> (kg)		40.3	46	51.7	60.2

<sup>2</sup> The value with 2 blocks (B type, without QZ) attached.  
<sup>3</sup> The maximum speed is restricted by the actuator's permissible speed.  
<sup>4</sup> The mass with 2 blocks (B type) has 6.6 kg added.

Without Cover  
Motor Wrap

Dimensions

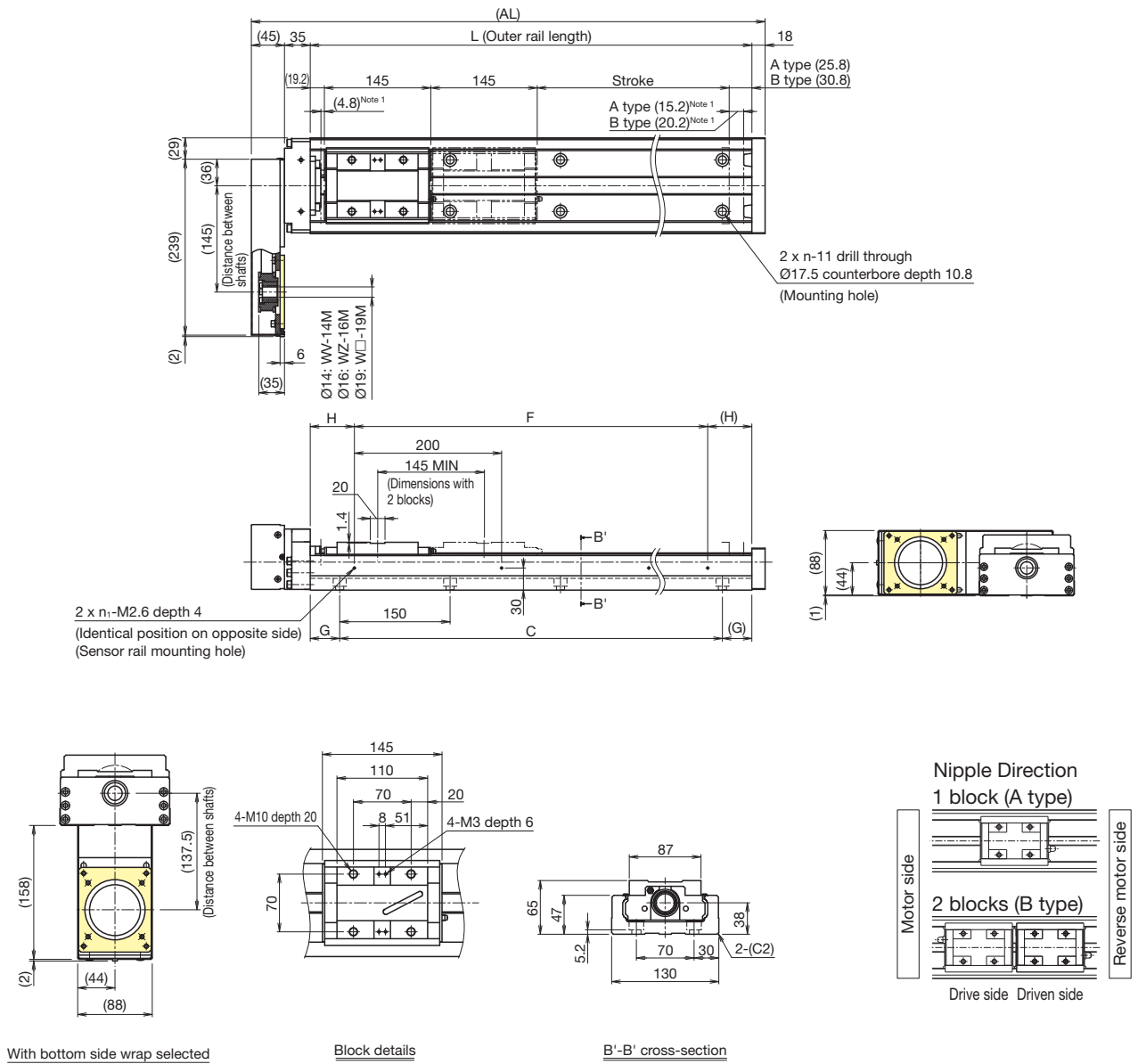

<sup>1</sup> Dimensions from the mechanical stopper to the stroke start position.

Stroke (mm) (Stroke between mechanical stoppers)	A type	790 (810)	990 (1,010)	1,190 (1,210)	1,490 (1,510)
	B type <sup>2</sup>	640 (665)	840 (865)	1,040 (1,065)	1,340 (1,365)
Maximum speed <sup>3</sup> (mm/s)	Ball screw lead: 25 mm	800			550
	Normal grade/high accuracy grade Precision grade	1,120			-
Dimensions (mm)	AL	1,078	1,278	1,478	1,778
	L	980	1,180	1,380	1,680
	C	900	1,050	1,200	1,500
	G	40	65	90	90
	F	800	1,000	1,200	1,600
	H	90	90	90	40
No. of mounting holes	n	7	8	9	11
	n <sub>1</sub>	5	6	7	9
Mass <sup>4</sup> (kg)		33.9	39.3	44.7	52.7

<sup>2</sup> The value with 2 blocks (B type, without QZ) attached.  
<sup>3</sup> The maximum speed is restricted by the actuator's permissible speed.  
<sup>4</sup> The mass with 2 blocks (B type) has 3.3 kg added.

# Options

## Sensors

Optional photo sensors and proximity sensors are available. Sensor-equipped models also feature a dedicated sensor rail and sensor dog.

Sensors, sensor rails, and sensor dogs can be mounted on both sides when the stroke is less than 70 mm.

Mounting example

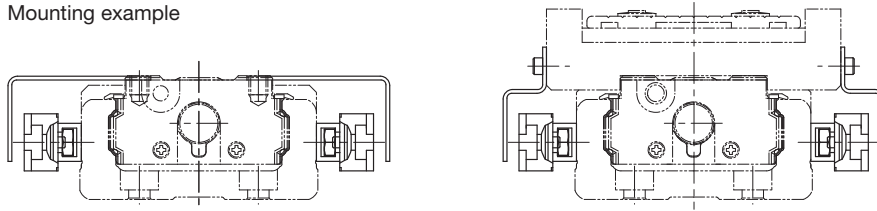

Symbol	Description	Model	Accessories
0	None	-	-
1	With sensor rail	-	Mounting screws, sensor rail (x1 or 2)
2	Photo sensor <sup>1</sup> (x3)	EE-SX671 (OMRON Corporation)	Mounting screws, nuts, sensor dog (x1 or 2), sensor rail (x1 or 2), mounting plates (x3), connectors (EE-1001 x3)
6	Photo sensor <sup>1</sup> (x3)	EE-SX674 (OMRON Corporation)	Mounting screws, nuts, sensor dog (x1 or 2), sensor rail (x1 or 2), mounting plates (x3), connectors (EE-1001 x3)
7	Proximity sensor N.O. contact <sup>2</sup> (x3)	APM-D3A1-001 (Azbil Corporation)	Mounting screws, nuts, sensor dog (x1 or 2), sensor rail (x1 or 2)
B	Proximity sensor N.C. contact <sup>3</sup> (x3)	APM-D3B1-003 (Azbil Corporation)	Mounting screws, nuts, sensor dog (x1 or 2), sensor rail (x1 or 2)
E	Proximity sensor N.O. contact <sup>2</sup> (x1) N.C. contact <sup>3</sup> (x2)	APM-D3A1-001 (Azbil Corporation) APM-D3B1-003 (Azbil Corporation)	Mounting screws, nuts, sensor dog (x1 or 2), sensor rail (x1 or 2)
H	Proximity sensor N.O. contact <sup>2</sup> (x3)	GX-F12A (Panasonic Industry Co., Ltd.)	Mounting screws, nuts, sensor dog (x1 or 2), sensor rail (x1 or 2)
L	Proximity sensor N.C. contact <sup>3</sup> (x3)	GX-F12B (Panasonic Industry Co., Ltd.)	Mounting screws, nuts, sensor dog (x1 or 2), sensor rail (x1 or 2)
J	Proximity sensor N.O. contact <sup>2</sup> (x1) N.C. contact <sup>3</sup> (x2)	GX-F12A (Panasonic Industry Co., Ltd.) GX-F12B (Panasonic Industry Co., Ltd.)	Mounting screws, nuts, sensor dog (x1 or 2), sensor rail (x1 or 2)
M	Proximity sensor N.O. contact <sup>2</sup> (x1) (PNP output) N.C. contact <sup>3</sup> (x2) (PNP output)	GX-F12A-P (Panasonic Industry Co., Ltd.) GX-F12B-P (Panasonic Industry Co., Ltd.)	Mounting screws, nuts, sensor dog (x1 or 2), sensor rail (x1 or 2)

<sup>1</sup> The photo sensors can be switched between ON when lit and ON when unlit.

<sup>2</sup> N.O. contact: Normally open contact point

<sup>3</sup> N.C. contact: Normally closed contact point

Notes: 1. If proximity sensors are close to one another, they may not function properly. If that happens, please prepare a type with a different frequency.

2. Mounting of sensors other than those in the table above is possible. Contact THK for details.

## Sensor Rail Mounting Dimensions

Mounting only a sensor rail is also possible.

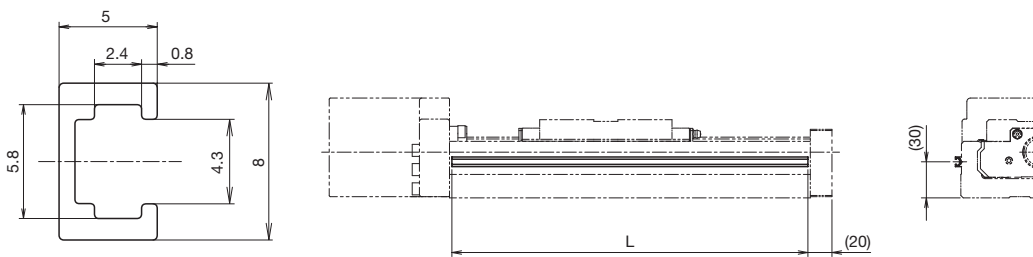

Sensor rail details

Stroke <sup>4</sup> (mm)	Outer rail length (mm)	L (mm)
790	980	976
990	1,180	1,176
1,190	1,380	1,376
1,490	1,680	1,676

<sup>4</sup> Stroke with 1 block (A type).

### Photo Sensor Mounting Dimensions

Connector: EE-1001 (OMRON Corporation) x3 included.  
To be mounted by the customer.

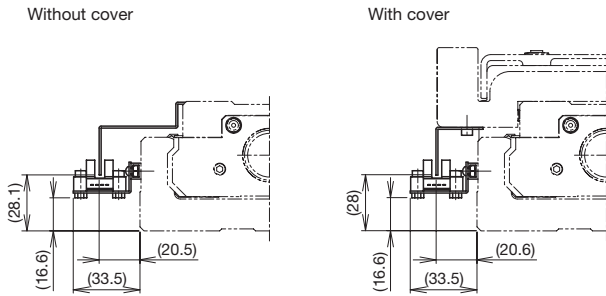

Symbol	Model	Manufacturer
2	EE-SX671	OMRON Corporation

Sensor dog width: 20 mm

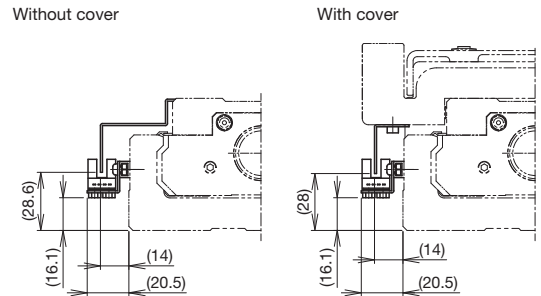

Symbol	Model	Manufacturer
6	EE-SX674	OMRON Corporation

Sensor dog width: 20 mm

### Proximity Sensor Mounting Dimensions

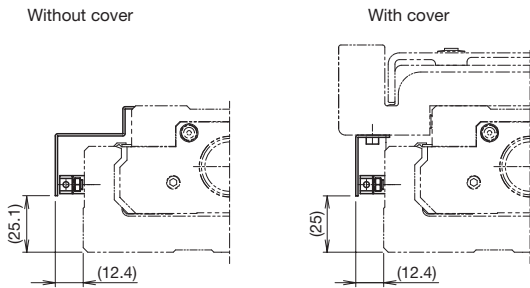

Symbol	Model	Manufacturer
7, B, E	APM-D3A1-001	Azbil Corporation
	APM-D3B1-003	

Sensor dog width: 20 mm

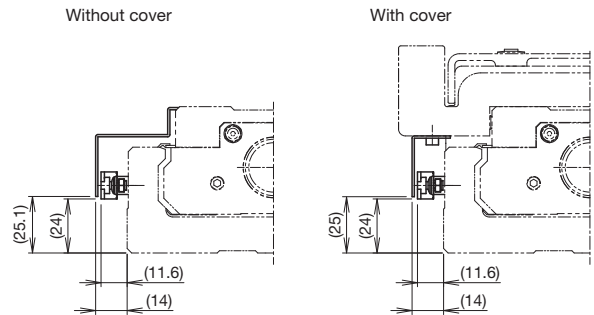

Symbol	Model	Manufacturer
H, L, J	GX-F12A	Panasonic Industry Co., Ltd.
	GX-F12B	
M	GX-F12A-P	
	GX-F12B-P	

Sensor dog width: 20 mm

# Options

## Intermediate Flange (Direct Coupling)

Several types of intermediate flanges for mounting motors are available.

When selecting "0" or "1" for Model Number Coding ⑦ With/without motor, specify an intermediate flange that matches the motor used.

Compatibility Table: Motors Used, Intermediate Flanges, and Couplings

Motor type	Manufacturer	Series	Motor model	Motor rated output (W)	Flange size	Housing A/ Intermediate flange	Compatible coupling models					
							MIKI PULLEY CO., LTD.	Nabeya Bi-tech Kaisha (NBK)				
AC servo motor	YASKAWA Electric Corporation	Σ-V	SGMJV-02	200	60×60	AV	SFC-035DA2-14B-15B	XGT2-30C-14-15				
			SGMAV-02									
			SGMJV-04	400								
			SGMAV-04									
			SGMJV-06	600								
			SGMJV-08									
		SGMAV-08	750	80×80	AZ	SFC-040DA2-15B-19B	XGT2-39C-15-19					
		Σ-7	SGM7J-02	200	60×60	AV	SFC-035DA2-14B-15B	XGT2-30C-14-15				
			SGM7A-02									
			SGM7J-04	400								
			SGM7A-04									
			SGM7J-06	600								
			SGM7J-08						750	80×80	AZ	SFC-040DA2-15B-19B
		SGM7A-08										
		Σ-X	SGMXJ-02	200	60×60	AV	SFC-035DA2-14B-15B	XGT2-30C-14-15				
			SGMXA-02									
			SGMXJ-04	400								
			SGMXA-04									
			SGMXJ-06	600								
			SGMXA-06									
			SGMXJ-08	750					80×80	AZ	SFC-040DA2-15B-19B	XGT2-39C-15-19
			SGMXA-08									
		Mitsubishi Electric Corporation	MELSERVO	J4	HG-KR23	200	60×60	AV	SFC-035DA2-14B-15B	XGT2-30C-14-15		
					HG-MR23							
	HG-KR43				400							
	HG-MR43											
	HG-KR73			750	80×80	AZ					SFC-040DA2-15B-19B	XGT2-39C-15-19
	HG-MR73											
	J5		HK-KT23W	200	60×60	AV	SFC-035DA2-14B-15B	XGT2-30C-14-15				
			HK-KT43W	400								
			HK-KT7M3W	750	80×80	AZ	SFC-040DA2-15B-19B	XGT2-39C-15-19				
	JN		HF-KN23	200	60×60	AV	SFC-035DA2-14B-15B	XGT2-30C-14-15				
			HF-KN43	400								
	TAMAGAWA SEIKI CO., LTD.		TBL-iii	TS4607	200	60×60	AV	SFC-035DA2-14B-15B	XGT2-30C-14-15			
		TS4609		400								
		TS4614		750	80×80					AZ	SFC-040DA2-15B-19B	XGT2-39C-15-19
		TSM3202		200	60×60					AV	SFC-035DA2-14B-15B	XGT2-30C-14-15
		TSM3204	400									
		TSM3303	600									
		TSM3304	750	80×80		AZ	SFC-040DA2-15B-19B	XGT2-39C-15-19				
Panasonic Corporation		MINAS	A5	MSMD08	750	80×80	A5	SFC-040DA2-15B-19B	XGT2-39C-15-19			
	MSME08											
	A6		MSMF08	750	80×80					A5	SFC-040DA2-15B-19B	XGT2-39C-15-19
			MHMF08									
KEYENCE CORPORATION	SV	SV-M020	200	60×60	AV	SFC-035DA2-14B-15B	XGT2-30C-14-15					
		SV-M040	400									
		SV-M075	750					80×80	AZ	SFC-040DA2-15B-19B	XGT2-39C-15-19	
	SV2	SV2-M020	200	60×60	AV	SFC-035DA2-14B-15B	XGT2-30C-14-15					
		SV2-M040	400									
		SV2-M075	750					80×80	AZ	SFC-040DA2-15B-19B	XGT2-39C-15-19	
SANYO DENKI CO., LTD.	SANMOTION R	R2□A06020	200	60×60	AV	SFC-035DA2-14B-15B	XGT2-30C-14-15					
		R2AA06040	400									
		R2AA08075	750					80×80	AZ	SFC-040DA2-15B-16B	XGT2-39C-15-16	
		R88M-K75030	750					80×80	A5	SFC-040DA2-15B-19B	XGT2-39C-15-19	
OMNUC G5	R88M-K75030	750										
OMRON Corporation	1S	R88M-1M75030	750	80×80								

Motor type	Manufacturer	Series	Motor model	Flange size	Housing A/ Intermediate flange	Compatible coupling models		
						MIKI PULLEY CO., LTD.	Nabeya Bi-tech Kaisha (NBK)	
Stepper motor	ORIENTAL MOTOR CO., LTD.	α step		AZ9*, AR9*	85×85	A6	SFC-035DA2-14B-15B	XGT2-34C-14-15
		5-phase	RK II	RKS59*	85×85	A6	SFC-035DA2-14B-15B	XGT2-34C-14-15

- Notes: 1. The table shows only a portion of the model numbers for motors. For details regarding model numbers, please see the catalog for each respective motor manufacturer.  
 2. If the maximum torque for motors exceeds the permissible input torque (p. 149), please consider a safety measure to limit the torque.  
 3. When installing a motor other than the motor model numbers listed above, contact THK.

Housing A

KR65
A0

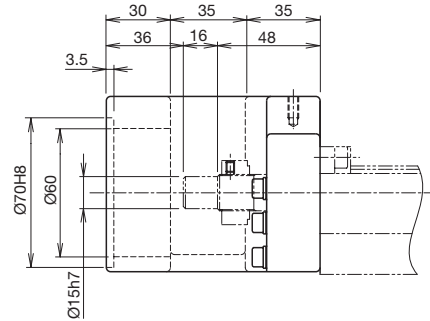
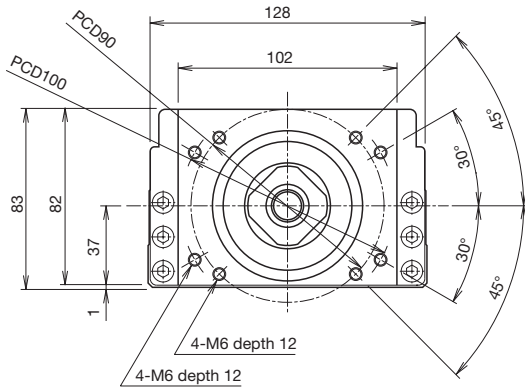

KR**	Actuator model
●◇	●: Housing A ◇: Intermediate flange

Intermediate Flange

KR65
AV

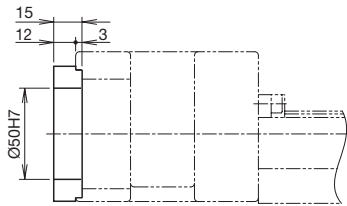
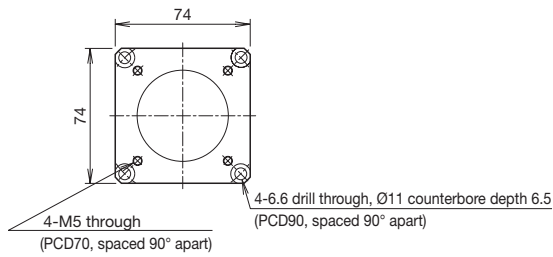

KR65
A5

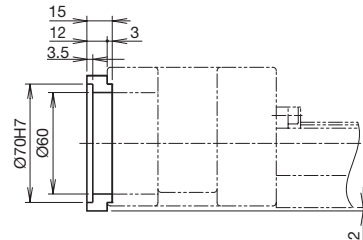
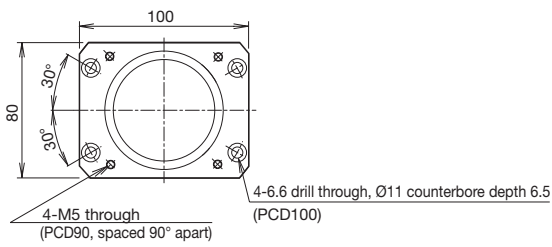

KR65
A6

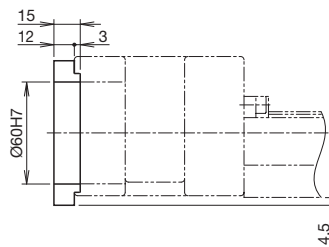
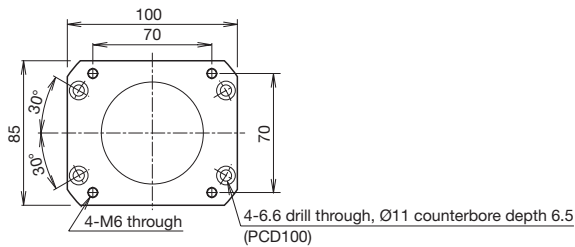

KR65
AZ

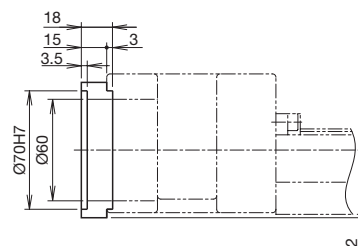
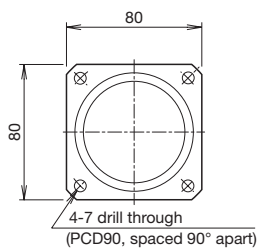

# Options

## Intermediate Flange (Motor Wrap)

Several types of intermediate flanges for mounting motors are available.

When selecting "R1," "R2," "R3," "R4," "R5," or "R6" for Model Number Coding ⑦ With/without motor, specify an intermediate flange that matches the motor used.

### Symbol Coding

Motor wrap symbol ①	Intermediate flange ②	Motor shaft diameter (mm) ③	Motor shaft securing method ④
W	Z	19	M
w	Refer to the Compatibility Table: Motors Used and Motor Wrap Symbols below.	Specify a motor shaft diameter. (Refer to the Compatibility Table: Motors Used and Motor Wrap Symbols below.)	M: Friction tightening tool

### Motor Shaft Securing Method

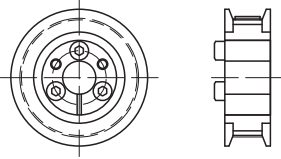

Friction tightening tool

Compatibility Table: Motors Used and Motor Wrap Symbols

Motor type	Manufacturer	Series	Motor model	Motor rated output (W)	Flange size	Housing A/Intermediate flange		
AC servo motor	YASKAWA Electric Corporation	Σ-V	SGMJV-02	200	60×60	WV-14M		
			SGMAV-02	400				
			SGMJV-04					
			SGMAV-04					
			SGMJV-06	750				
			SGMJV-08					
		SGMAV-08	80×80	WZ-19M				
		SGM7J-02			200			
		SGM7A-02						
		SGM7J-04						
		SGM7A-04			400	60×60	WV-14M	
		SGM7J-06						
		SGM7A-06						
		SGM7J-08	750	80×80	WZ-19M			
		SGM7A-08						
		SGMXJ-02				200		
		SGMXA-02						
		SGMXJ-04	400	60×60	WV-14M			
	SGMXA-04							
	SGMXJ-06							
	SGMXA-06	600	80×80	WZ-19M				
	SGMXJ-08							
	SGMXA-08							
	Mitsubishi Electric Corporation	MELSERVO	J4	HG-KR23	200	60×60	WV-14M	
				HG-MR23	400			
				HG-KR43				
				HG-MR43		750		80×80
				HG-KR73				
				HG-MR73				
			J5	HK-KT23W	200	60×60	WV-14M	
				HK-KT43W	400			
				HK-KT7M3W	750			
			JN	HF-KN23	200	60×60	WV-14M	
				HF-KN43	400			
	TAMAGAWA SEIKI CO., LTD.	TBL-iii	TS4607	200	60×60	WV-14M		
			TS4609	400				
			TS4614	750				
		TBL-iiV	TSM3202	200	60×60	WV-14M		
			TSM3204	400				
TSM3303			600					
		TSM3304	750	80×80	WZ-19M			
Panasonic Corporation	MINAS	A5	MSPD08	750	80×80	W5-19M		
			MSME08					
		A6	MSPF08					
			MHMF08					
KEYENCE CORPORATION	SV	SV-M020	200	60×60	WV-14M			
		SV-M040	400					
		SV-M075	750					
	SV2	SV2-M020	200	60×60	WV-14M			
		SV2-M040	400					
		SV2-M075	750					
SANYO DENKI CO., LTD.	SANMOTION R	R2□A06020	200	60×60	WV-14M			
		R2AA06040	400					
		R2AA08075	750					
OMRON Corporation	OMNUC G5	R88M-K75030	750	80×80	W5-19M			
		1S R88M-1M75030						

Notes: 1. The table shows only a portion of the model numbers for motors. For details regarding model numbers, please see the catalog for each respective motor manufacturer.  
 2. If the maximum torque for motors exceeds the permissible input torque (p. 149), please consider a safety measure to limit the torque.  
 3. When installing a motor other than the motor model numbers listed above, contact THK.

Motor Wrap Housing A

KR65
30

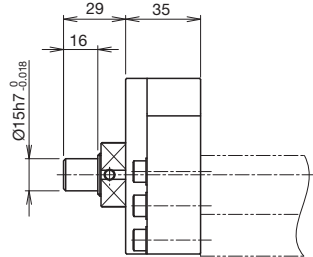
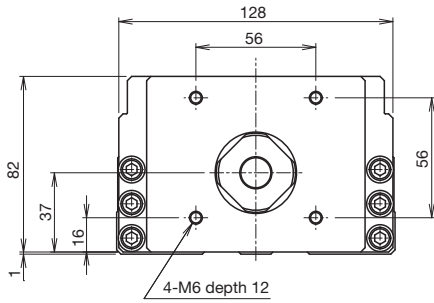

KR**	Actuator model
●◇	●: Housing A ◇: Intermediate flange

Motor Wrap Specification (Intermediate Flange)

KR65
WV

Thickness: 6 mm

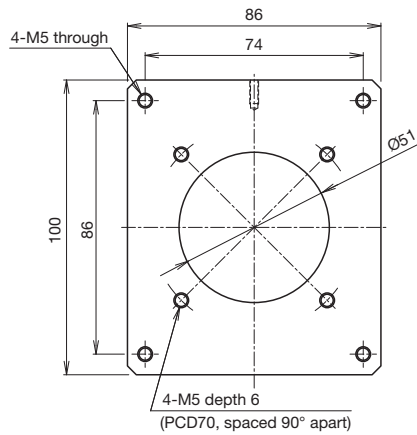

KR65
W5

Thickness: 6 mm

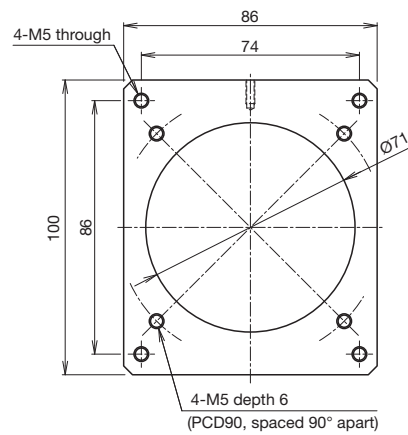

KR**	Actuator model
W□	□: Intermediate flange

KR65
WZ

Thickness: 6 mm

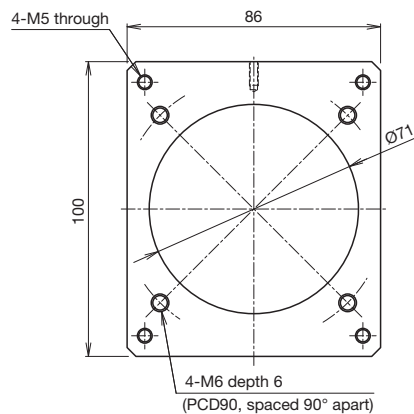

## Options

### QZ Lubricator

The QZ Lubricator for KR feeds the right amount of lubricant to the outer rail and ball screw shaft raceways. This allows an oil film to be constantly formed between the balls and the raceway, and it significantly extends the lubrication maintenance interval.

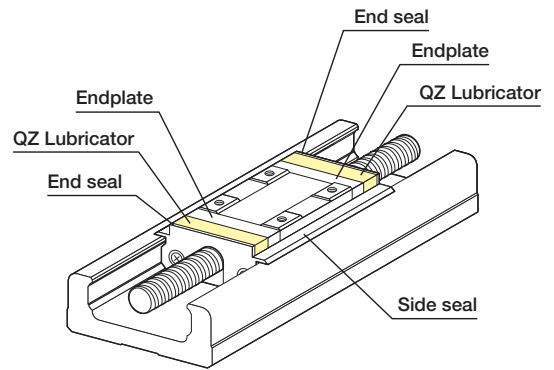

Appearance

### Features

- Since it compensates for oil loss, the lubrication maintenance interval can be significantly extended.
- It is an eco-friendly lubrication system that does not contaminate the surrounding area, as it feeds the right amount of lubricant to the ball raceway.

### QZ Configuration

Symbol	Block type	Description
QZ	A/B	QZ all-block double-sided specification
QZA	A	QZ fixed side specification
QZB	A	QZ supported side specification
QZAD	B	QZ fixed side (drive side block) + QZ supported side (driven side block) specification

Note: QZ specification types do not have a grease nipple mounted. Contact THK if a grease nipple is required.

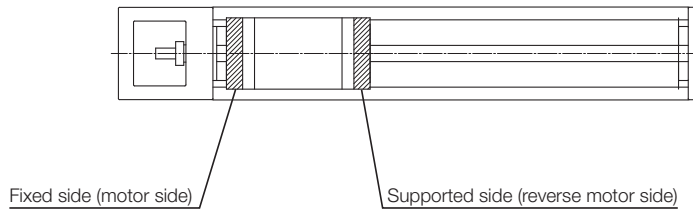

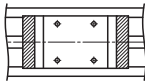
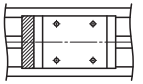
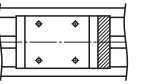
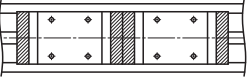
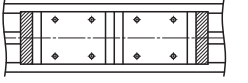
Block type	QZ configuration	QZ	QZA	QZB	QZAD
	A type (1 block)		 Fixed side	 Supported side	 Fixed side
B type (2 blocks)		 Fixed side	-	-	 Supported side

### Dimensions with QZ Lubricator

QZ (With Cover)  
Block Type: A/B

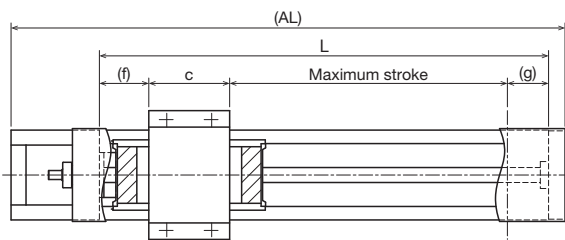

Block Type A

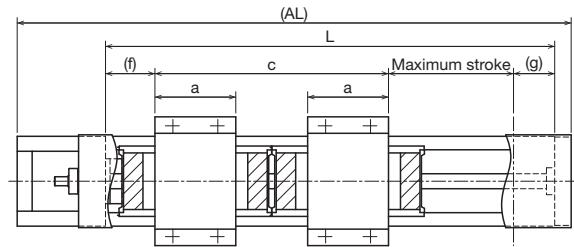

Block Type B

Unit: mm

Block type	Overall length AL	Outer rail length L	Stroke <sup>1</sup>	Maximum stroke <sup>1</sup>	a	c	f	g
A	1,098	980	760	778	-	110	47.9	44.1
	1,298	1,180	960	978				
	1,498	1,380	1,160	1,178				
	1,798	1,680	1,460	1,478				
B	1,098	980	580	601	110	287	47.9	44.1
	1,298	1,180	780	801				
	1,498	1,380	980	1,001				
	1,798	1,680	1,280	1,301				

<sup>1</sup> The value for B block types is with 2 blocks attached.

QZ (Without Cover)  
Block Type: A/B

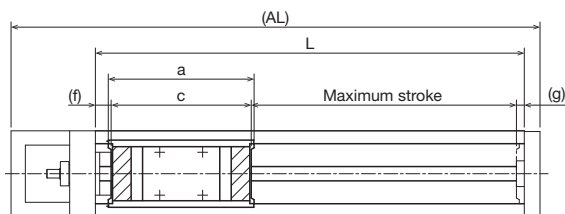

Block Type A

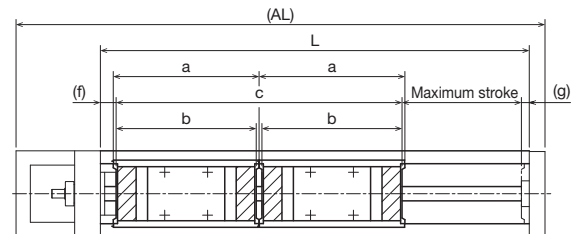

Block Type B

Unit: mm

Block type	Overall length AL	Outer rail length L	Stroke <sup>2</sup>	Maximum stroke <sup>2</sup>	a	b	c	f	g
A	1,098	980	760	778	177	-	177	14.4	10.6
	1,298	1,180	960	978					
	1,498	1,380	1,160	1,178					
	1,798	1,680	1,460	1,478					
B	1,098	980	580	601	177	177	354	14.4	10.6
	1,298	1,180	780	801					
	1,498	1,380	980	1,001					
	1,798	1,680	1,280	1,301					

<sup>2</sup> The value for B block types is with 2 blocks attached.

# Options

## Dimensions with QZ Lubricator

**QZA (With Cover)**  
Block Type: A

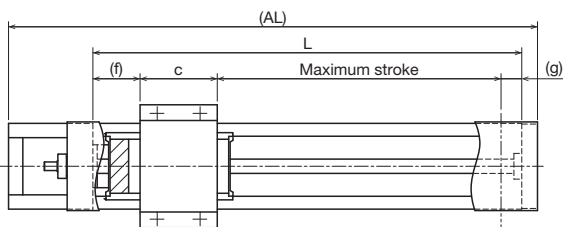

Block Type A

**QZA (Without Cover)**  
Block Type: A

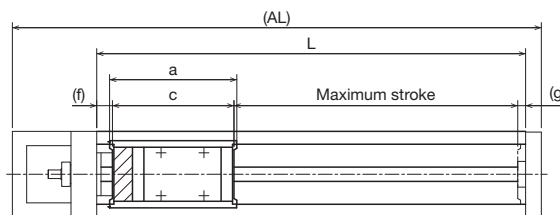

Block Type A

**QZA (With Cover)**

Unit: mm

Block type	Overall length AL	Outer rail length L	Stroke	Maximum stroke	c	f	g
A	1,098	980	775	794	110	47.9	28.1
	1,298	1,180	975	994			
	1,498	1,380	1,175	1,194			
	1,798	1,680	1,475	1,494			

Note 1: B block types cannot be selected for QZA.

**QZA (Without Cover)**

Unit: mm

Block type	Overall length AL	Outer rail length L	Stroke	Maximum stroke	a	c	f	g
A	1,098	980	775	794	161	161	14.4	10.6
	1,298	1,180	975	994				
	1,498	1,380	1,175	1,194				
	1,798	1,680	1,475	1,494				

Note 2: B block types cannot be selected for QZA.

**QZB (With Cover)**  
Block Type: A

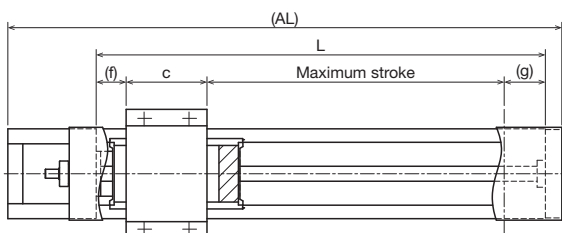

Block Type A

**QZB (Without Cover)**  
Block Type: A

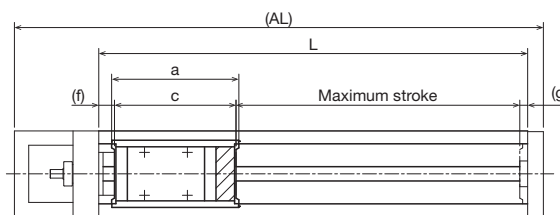

Block Type A

**QZB (With Cover)**

Unit: mm

Block type	Overall length AL	Outer rail length L	Stroke	Maximum stroke	c	f	g
A	1,098	980	775	794	110	31.9	44.1
	1,298	1,180	975	994			
	1,498	1,380	1,175	1,194			
	1,798	1,680	1,475	1,494			

Note 3: B block types cannot be selected for QZB.

**QZB (Without Cover)**

Unit: mm

Block type	Overall length AL	Outer rail length L	Stroke	Maximum stroke	a	c	f	g
A	1,098	980	775	794	161	161	14.4	10.6
	1,298	1,180	975	994				
	1,498	1,380	1,175	1,194				
	1,798	1,680	1,475	1,494				

Note 4: B block types cannot be selected for QZB.

### Dimensions with QZ Lubricator

#### QZAD (With Cover) Block Type: B

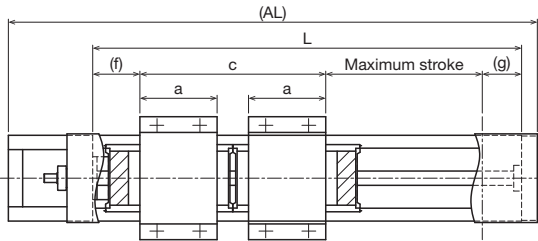

Block Type B

#### QZAD (Without Cover) Block Type: B

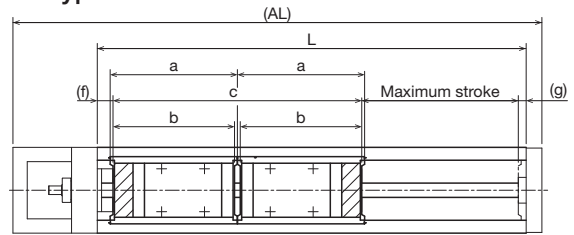

Block Type B

#### QZAD (With Cover)

Unit: mm

Block type	Overall length AL	Outer rail length L	Stroke <sup>1</sup>	Maximum stroke <sup>1</sup>	a	c	f	g
B	1,098	980	610	633	110	255	47.9	44.1
	1,298	1,180	810	833				
	1,498	1,380	1,010	1,033				
	1,798	1,680	1,310	1,333				

<sup>1</sup> The value for B block types is with 2 blocks attached.

Note 1: A block types cannot be selected for QZAD.

#### QZAD (Without Cover)

Unit: mm

Block type	Overall length AL	Outer rail length L	Stroke <sup>2</sup>	Maximum stroke <sup>2</sup>	a	b	c	f	g
B	1,098	980	610	633	161	161	322	14.4	10.6
	1,298	1,180	810	833					
	1,498	1,380	1,010	1,033					
	1,798	1,680	1,310	1,333					

<sup>2</sup> The value for B block types is with 2 blocks attached.

Note 2: A block types cannot be selected for QZAD.

# Bellows

In addition to a cover, bellows are available for the KR for dust-proofing purposes.

## KR-A (1 Block)

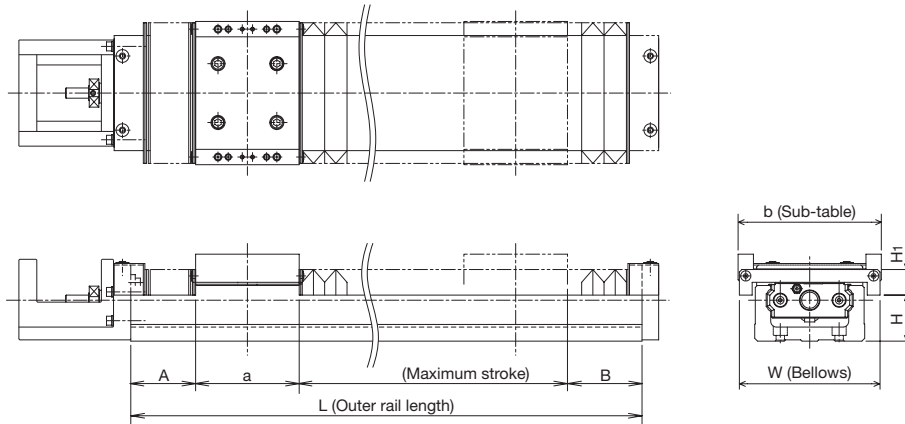

Unit: mm

Model	Stroke	Maximum stroke	Outer rail length L	A	B	a	b	W	H	H <sub>1</sub>
KR15	15	22.2	75	15.8	14	23	44	49	8	15.5
	30	37.2	100	20.8	19					
	45	52.2	125	25.8	24					
	60	67.2	150	30.8	29					
	75	82.2	175	35.8	34					
KR20	90	97.2	200	40.8	39	33.2	52	60	10	20
	20	30.8	100	18.8	17.2					
	55	67.8	150	25.3	23.7					
KR26	80	93.6	200	37	36.2	47.4	62	74	18	20
	50	61.3	150	23.7	17.6					
	80	91.6	200	32.8	28.2					
	110	125.6	250	40.8	36.2					
KR30H	160	175.6	300	40.8	36.2	54	80	80	21.5	17.5
	30	42	150	28.5	25.5					
	60	72	200	38.5	35.5					
	130	142	300	53.5	50.5					
	200	212	400	68.5	65.5					
KR33	270	282	500	83.5	80.5	54	86	84	24.5	20
	340	352	600	98.5	95.5					
	30	42	150	28.4	25.6					
	70	82	200	33.4	30.6					
	150	162	300	43.4	40.6					
	220	232	400	58.4	55.6					
KR45H	300	312	500	68.4	65.6	81	104	104	28	28
	370	382	600	83.4	80.6					
	450	462	700	93.4	90.6					
	160	177	340	41.1	40.9					
	240	255	440	52.1	51.9					
	320	339	540	60.1	59.9					
KR46	400	423	640	68.1	67.9	81	112	110	36	20
	470	491	740	84.1	83.9					
	550	575	840	92.1	91.9					
	640	659	940	100.1	99.9					
	140	155	340	52.9	51.1					
	210	225	440	67.9	66.1					
KR55 <sup>1</sup>	290	305	540	77.9	76.1	95.2	124	154	37	40
	360	375	640	92.9	91.1					
	440	455	740	102.9	101.1					
	510	525	840	117.9	116.1					
	590	605	940	127.9	126.1					
KR65 <sup>1</sup>	700	719.6	980	84.6	80.6	110	170	184	40	47
	790	809.6	1,080	89.6	85.6					
	870	889.6	1,180	99.6	95.6					
	960	979.6	1,280	104.6	100.6					
KR65 <sup>1</sup>	1,050	1,069.6	1,380	109.6	105.6	110	170	184	40	47
	680	703.2	980	85.1	81.7					
	860	883.2	1,180	95.1	91.7					
KR65 <sup>1</sup>	1,030	1,053.2	1,380	110.1	106.7	110	170	184	40	47
	1,290	1,313.2	1,680	130.1	126.7					

<sup>1</sup> The bellows for models KR55 and KR65 are only suitable for horizontal orientation. If the bellows are to be used in other orientations (vertical or wall-mounted), contact THK.

## KR-B (2 Blocks)

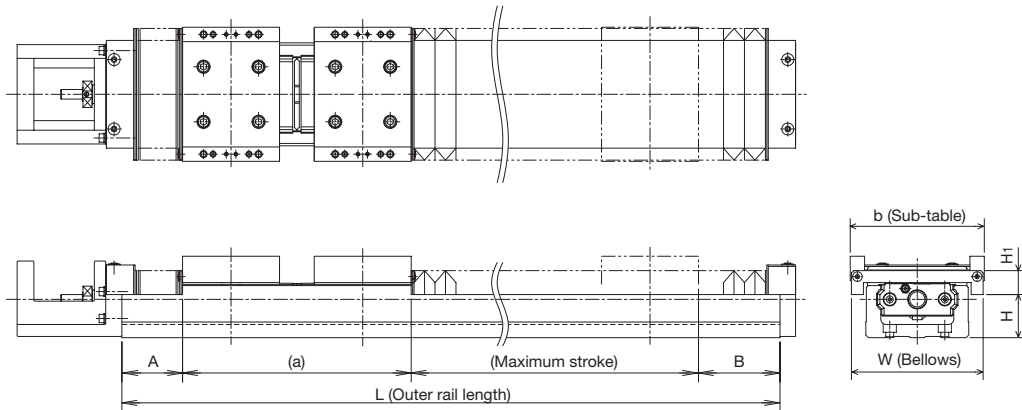

Unit: mm

Model	Stroke <sup>1</sup>	Maximum stroke <sup>1</sup>	Outer rail length L	A	B	a <sup>1</sup>	b	W	H	H <sub>1</sub>
KR15	20	29.2	125	20.8	19	56	44	49	8	15.5
	35	44.2	150	25.8	24					
	50	59.2	175	30.8	29					
	65	74.2	200	35.8	34					
KR20	25	34.8	150	18.8	17.2	79.2	52	60	10	20
	60	71.8	200	25.3	23.7					
KR26	35	47.3	200	23.7	17.6	111.4	62	74	18	20
	65	77.6	250	32.8	28.2					
	115	127.6	300	32.8	28.2					
KR30H	85	97.6	300	38.5	35.5	128.4	80	80	21.5	17.5
	155	167.6	400	53.5	50.5					
	225	237.6	500	68.5	65.5					
	295	307.6	600	83.5	80.5					
KR33	80	96	300	38.4	35.6	130	86	84	24.5	20
	160	176	400	48.4	45.6					
	240	256	500	58.4	55.6					
	310	326	600	73.4	70.6					
	390	406	700	83.4	80.6					
KR45H	80	95	340	28.1	27.9	189	104	104	28	28
	155	170.5	440	41.1	39.4					
	230	247	540	52.1	51.9					
	310	331	640	60.1	59.9					
	400	415	740	68.1	67.9					
	465	483	840	84.1	83.9					
KR46	60	75	340	37.9	36.1	191	112	110	36	20
	130	145	440	52.9	51.1					
	210	225	540	62.9	61.1					
	280	295	640	77.9	76.1					
	360	375	740	87.9	86.1					
	430	445	840	102.9	101.1					
	510	525	940	112.9	111.1					
KR55 <sup>2</sup>	590	612	980	74.6	70.6	222.8	124	154	37	40
	670	692	1,080	84.6	80.6					
	760	782	1,180	89.6	85.6					
	850	872	1,280	94.6	90.6					
	930	952	1,380	104.6	100.6					
KR65 <sup>2</sup>	550	578.6	980	75.1	71.7	254.6	170	184	40	47
	720	748.6	1,180	90.1	86.7					
	900	928.6	1,380	100.1	96.7					
	1,160	1,188.6	1,680	120.1	116.7					

<sup>1</sup> The value with 2 blocks (B type) attached.

<sup>2</sup> The bellows for models SKR55 and SKR65 are only suitable for horizontal orientation. If the bellows are to be used in other orientations (vertical or wall-mounted), contact THK.  
Note: Bellows cannot be attached between sub-tables.

# Bellows

## KR-C (1 Short Block)

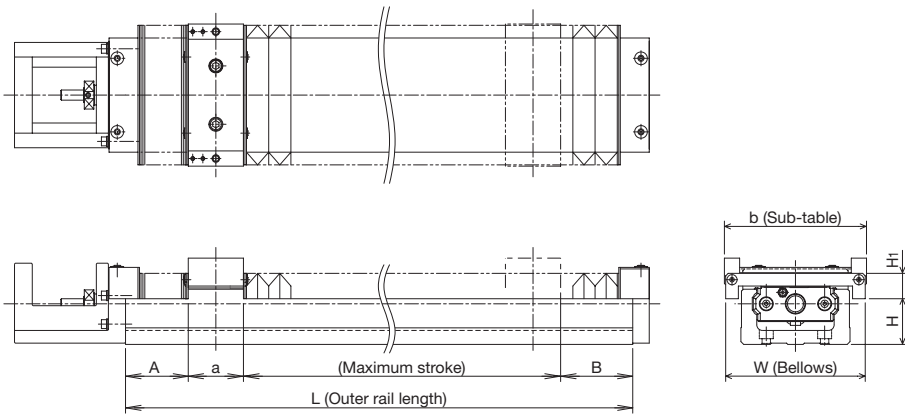

Unit: mm

Model	Stroke	Maximum stroke	Outer rail length L	A	B	a	b	W	H	H <sub>1</sub>
KR30H	45	57.5	150	33.5	30.5	28.5	80	80	21.5	17.5
	85	97.5	200	38.5	35.5					
	155	167.5	300	53.5	50.5					
	225	237.5	400	68.5	65.5					
	295	307.5	500	83.5	80.5					
	365	377.5	600	98.5	95.5					
KR33	55	67.5	150	28.4	25.6	28.5	86	84	24.5	20
	95	107.5	200	33.4	30.6					
	165	177.5	300	48.4	45.6					
	245	257.5	400	58.4	55.6					
	315	327.5	500	73.4	70.6					
	395	407.5	600	83.4	80.6					
KR45H	190	208.5	340	44.1	43.9	43.5	104	104	28	28
	275	292.5	440	52.1	51.9					
	340	360.5	540	68.1	67.9					
	425	444.5	640	76.1	75.9					
	510	528.5	740	84.1	83.9					
	580	596.5	840	100.1	99.9					
KR46	170	182.5	340	57.9	56.1	43.5	112	110	36	20
	240	252.5	440	72.9	71.1					
	320	332.5	540	82.9	81.1					
	390	402.5	640	97.9	96.1					
	470	482.5	740	107.9	106.1					
	540	552.5	840	122.9	121.1					
	620	632.5	940	132.9	131.1					

## KR-D (2 Short Blocks)

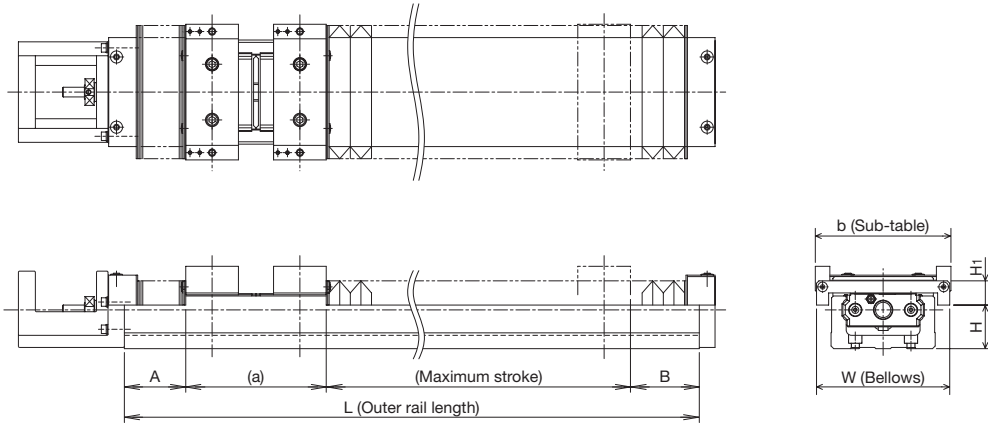

Unit: mm

Model	Stroke <sup>1</sup>	Maximum stroke <sup>1</sup>	Outer rail length L	A	B	a <sup>1</sup>	b	W	H	H <sub>1</sub>
KR30H	15	28.6	150	23.5	20.5	77.4	80	80	21.5	17.5
	45	58.6	200	33.5	30.5					
	115	128.6	300	48.5	45.5					
	185	198.6	400	63.5	60.5					
	255	268.6	500	78.5	75.5					
	325	338.6	600	93.5	90.5					
KR33	55	67	200	28.4	25.6	79	86	84	24.5	20
	125	137	300	43.4	40.6					
	205	217	400	53.4	50.6					
	275	287	500	68.4	65.6					
	355	367	600	78.4	75.6					
KR45H	140	154	340	36.1	35.9	114	104	104	28	28
	220	238	440	44.1	43.9					
	290	306	540	60.1	59.9					
	370	390	640	68.1	67.9					
	455	474	740	76.1	75.9					
	525	542	840	92.1	91.9					
KR46	110	130	340	47.9	46.1	116	112	110	36	20
	180	200	440	62.9	61.1					
	260	280	540	72.9	71.1					
	330	350	640	87.9	86.1					
	410	430	740	97.9	96.1					
	480	500	840	112.9	111.1					
	560	580	940	122.9	121.1					

<sup>1</sup> The value with 2 short blocks (D type) attached.

Note: Bellows cannot be attached between sub-tables.

# Maximum Load Capacity Guidelines by Acceleration

## Horizontal

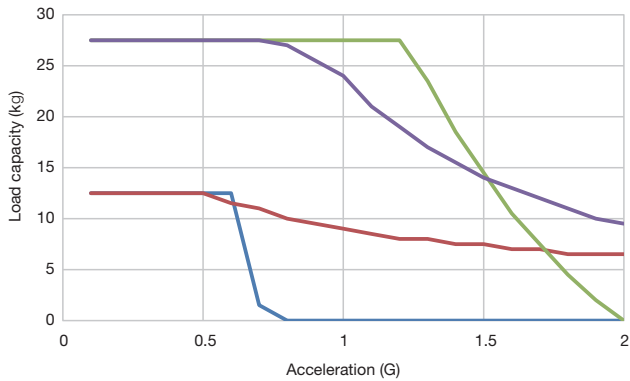

Unit: kg

	0.15 G	0.3 G	0.5 G	1 G	1.5 G	2 G
KR2001A	12.5	12.5	12.5	-	-	-
KR2006A	12.5	12.5	12.5	9	7.5	6.5
KR2602A	27.5	27.5	27.5	27.5	14.5	-
KR2606A	27.5	27.5	27.5	24	14	9.5

## Wall-Mounted

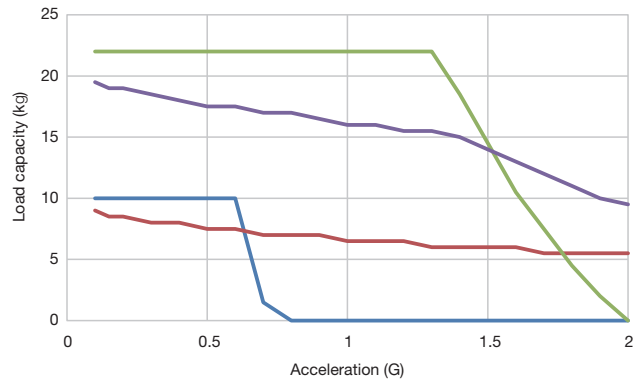

Unit: kg

	0.15 G	0.3 G	0.5 G	1 G	1.5 G	2 G
KR2001A	10	10	10	-	-	-
KR2006A	8.5	8	7.5	6.5	6	5.5
KR2602A	22	22	22	22	14.5	-
KR2606A	19	18.5	17.5	16	14	9.5

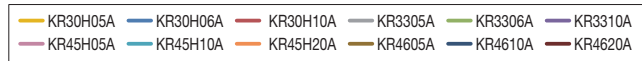
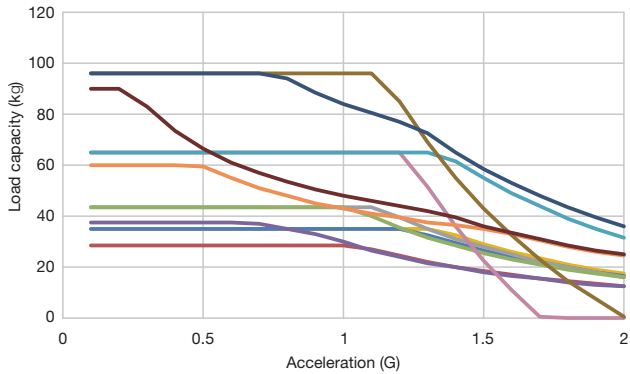

Unit: kg

	0.15 G	0.3 G	0.5 G	1 G	1.5 G	2 G
KR30H05	35	35	35	35	29	17.5
KR30H06A	35	35	35	35	26.5	16.5
KR30H10A	28.5	28.5	28.5	28.5	18.5	12.5
KR3305A	43.5	43.5	43.5	43.5	28	16
KR3306A	43.5	43.5	43.5	43.5	25.5	16
KR3310A	37.5	37.5	37.5	30	18	12.5
KR45H05	65	65	65	65	22.5	0
KR45H10A	65	65	65	65	55	31.5
KR45H20A	60	60	59.5	43	35	24.5
KR4605A	96	96	96	96	43	0.5
KR4610A	96	96	96	84	58.5	36
KR4620A	90	83	66.5	48	36	25

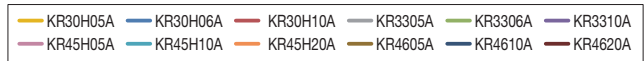
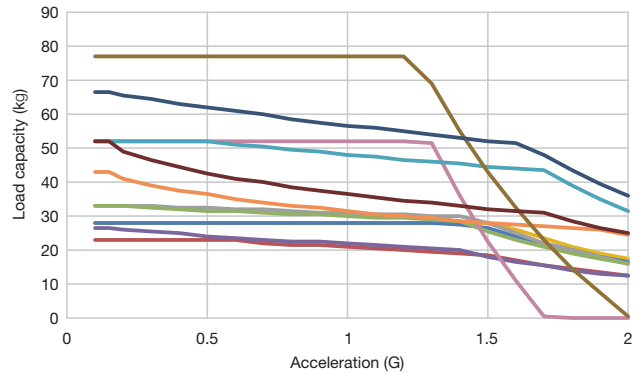

Unit: kg

	0.15 G	0.3 G	0.5 G	1 G	1.5 G	2 G
KR30H05	28	28	28	28	28	17.5
KR30H06A	28	28	28	28	26.5	16.5
KR30H10A	23	23	23	21	18.5	12.5
KR3305A	33	33	32.5	31	28	16
KR3306A	33	32.5	31.5	30	25.5	16
KR3310A	26.5	25.5	24	22	18	12.5
KR45H05	52	52	52	52	22.5	0
KR45H10A	52	52	52	48	44.5	31.5
KR45H20A	43	39	36.5	31.5	28	24.5
KR4605A	77	77	77	77	43	0.5
KR4610A	66.5	64.5	62	56.5	52	36
KR4620A	52	46.5	42.5	36.5	32	25

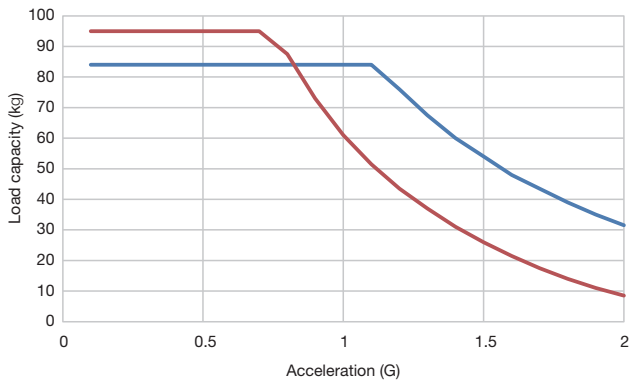

Unit: kg

	0.15 G	0.3 G	0.5 G	1 G	1.5 G	2 G
KR5520A	84	84	84	84	54	31.5
KR6525A	95	95	95	61	26	8.5

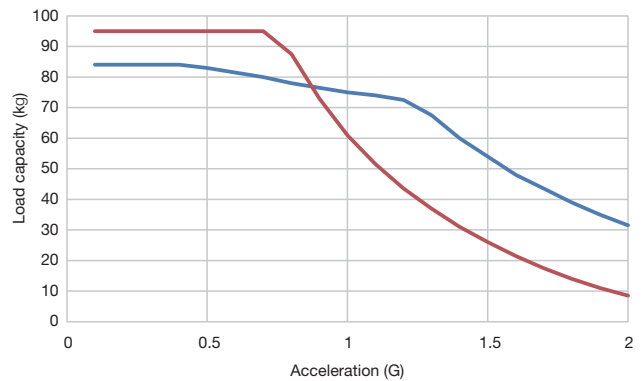

Unit: kg

	0.15 G	0.3 G	0.5 G	1 G	1.5 G	2 G
KR5520A	84	84	83	75	54	31.5
KR6525A	95	95	95	61	26	8.5

Vertical

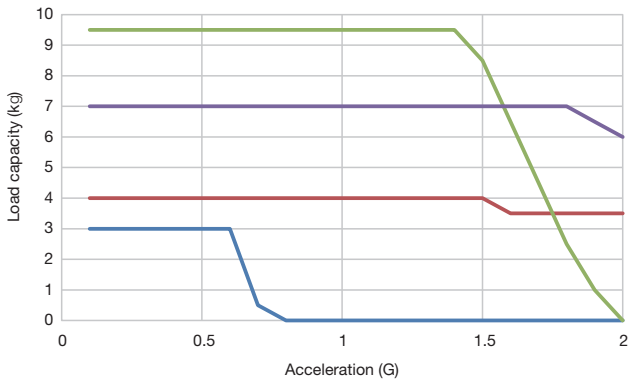

— KR2001A — KR2006A — KR2602A — KR2606A  
Unit: kg

	0.15 G	0.3 G	0.5 G	1 G	1.5 G	2 G
KR2001A	3	3	3	-	-	-
KR2006A	4	4	4	4	4	3.5
KR2602A	9.5	9.5	9.5	9.5	8.5	-
KR2606A	7	7	7	7	7	6

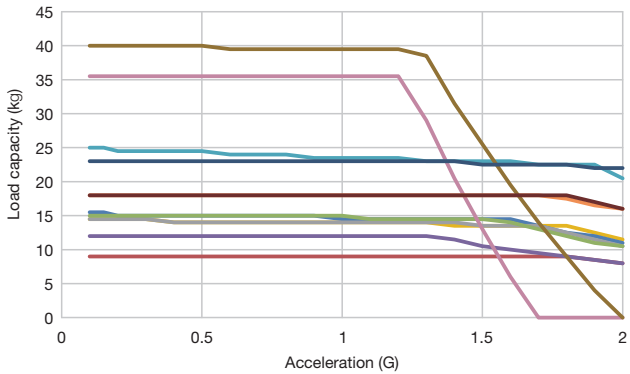

— KR30H05A — KR30H06A — KR30H10A — KR3305A — KR3306A — KR3310A  
— KR45H05A — KR45H10A — KR45H20A — KR4605A — KR4610A — KR4620A  
Unit: kg

	0.15 G	0.3 G	0.5 G	1 G	1.5 G	2 G
KR30H05	14.5	14.5	14	14	13.5	11.5
KR30H06A	15.5	15	15	14.5	14.5	11
KR30H10A	9	9	9	9	9	8
KR3305A	14.5	14.5	14	14	13.5	10.5
KR3306A	15	15	15	15	14.5	10.5
KR3310A	12	12	12	12	10.5	8
KR45H05	35.5	35.5	35.5	35.5	13	0
KR45H10A	25	24.5	24.5	23.5	23	20.5
KR45H20A	18	18	18	18	18	16
KR4605A	40	40	40	39.5	25.5	-
KR4610A	23	23	23	23	22.5	22
KR4620A	18	18	18	18	18	16

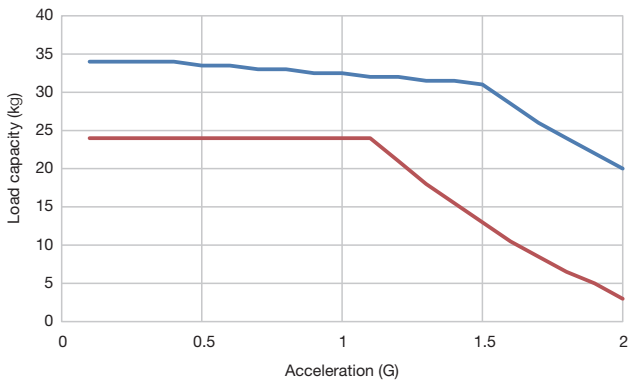

— KR5520A — KR6525A  
Unit: kg

	0.15 G	0.3 G	0.5 G	1 G	1.5 G	2 G
KR5520A	34	34	33.5	32.5	31	20
KR6525A	24	24	24	24	13	3

Calculation Conditions

Model	Lead (mm)	Stroke* (mm)	Estimated motor capacity (W)	Speed (mm/s)	Center of gravity
KR20	1	80	50	50	Center of table upper surface
	6			300	
KR26	2	160	50	100	
	6			300	
KR30H	5	300	100	250	
	6			300	
	10			500	
KR33	5	400	100	250	
	6			300	
	10			500	
KR45H	5	500	400	240	
	10			500	
	20			1,000	
KR46	5	490	400	240	
	10			500	
	20			1,000	
KR55	20	1,000	750	800	
KR65	25	1,190	750	800	

\* Stroke with 1 block (A type).

# Load Rating and Static Permissible Moment for Each Direction

## Load Rating

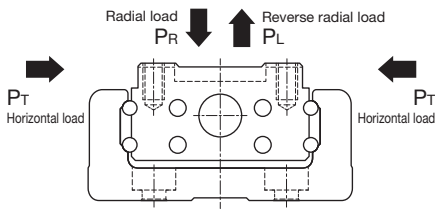

KR: 4-way loads

- LM Guide  
The KR can receive loads in 4 directions (radial, reverse radial, and horizontal directions). The basic load rating is when each of the 4 directions is equal. These values are listed in the "Load Rating" table below.
- Ball screw  
The KR has a ball screw nut built into the inner block to enable axial loads to be applied. The basic load rating is listed in the "Load Rating" table below.
- Bearing (fixed side)  
The KR's housing A has an embedded angular bearing to enable axial loads to be applied. The basic load rating is listed in the "Load Rating" table below.

## Equivalent Load (LM Guide)

The equivalent load when the LM Guide unit of the Model KR simultaneously receives loads in all directions is obtained from the following formula.

$$P_E = P_R(P_L) + P_T$$

$P_E$ : Equivalent load (N)  
 $P_R$ : Radial load (N)

$P_L$ : Reverse radial load (N)  
 $P_T$ : Horizontal load (N)

## Load Rating

Model		KR15		KR20		KR26		KR30H			KR33			KR45H			KR46			KR55	KR65	
		KR1501	KR1502	KR2001	KR2006	KR2602	KR2606	KR30H05	KR30H06	KR30H10	KR3305	KR3306	KR3310	KR45H05	KR45H10	KR45H20	KR4605	KR4610	KR4620			
LM Guide	Basic dynamic load rating $C$ (N)	1 block (A type)		3,590		7,240		11,600			11,600			23,300			27,400			38,100	50,900	
		1 short block (C type)		-		-		4,900			4,900			11,900			14,000			-	-	
	Basic static load rating $C_0$ (N)	1 block (A type)		6,300		12,150		20,200			20,200			39,200			45,500			61,900	80,900	
		1 short block (C type)		-		-		10,000			10,000			19,600			22,700			-	-	
Ball screw	Ball screw lead (mm)		1	2	1	6	2	6	5	6	10	5	6	10	5	10	20	5	10	20	20	25
	Basic dynamic load rating $C_a$ (N)	Normal grade/ High accuracy grade (H)		660		2,350		1,950	3,370	2,840	1,760	3,370	2,840	1,760	5,500	3,140	3,040	5,500	3,140	3,040	3,620	5,680
		Precision grade (P)		1,060		2,390		1,860	2,250	1,370	1,860	2,250	1,370	4,100	2,940	3,430	4,100	2,940	3,430	3,980	5,950	
	Basic static load rating $C_{0a}$ (N)	Normal grade/ High accuracy grade (H)		1,170		4,020		3,510	5,390	4,900	2,840	5,390	4,900	2,840	13,900	6,760	7,150	13,900	6,760	7,150	9,290	14,500
Precision grade (P)		1,600		3,900		2,690	2,740	1,570	2,690	2,740	1,570	6,960	3,720	5,290	6,960	3,720	5,290	6,850	10,700			
Bearing unit (fixed side)	Axial direction	Basic dynamic load rating $C_{0a}$ (N)		1,000		1,380		1,790			1,790			6,660			6,660			7,600	13,700	
		Static permissible load $P_{0a}$ (N)		1,240		1,760		2,590			2,590			3,240			3,240			3,990	5,830	

- Notes: 1. LM Guide load rating is the load rating per block.  
2. KR30H, KR33, KR45H10, and KR4610 precision grade (P-grade) ball screws have integrated spacer balls with a 1:1 ratio.  
3. KR45H20, KR4620, KR55, and KR65 precision grade (P-grade) ball screws have integrated spacer balls with a 2:1 ratio.

## Static Permissible Moment (LM Guide)

The KR LM Guide supports moment loads in 3 directions with a single block.

A: 1 block (A type)

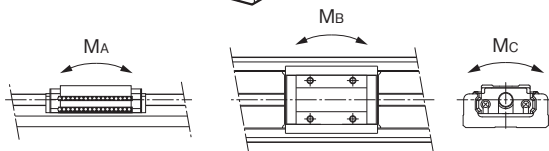
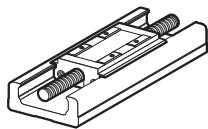

C: 1 short block (C type)

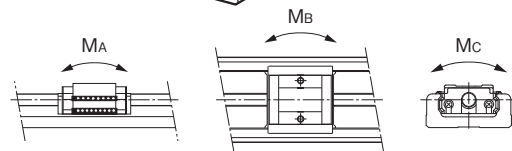
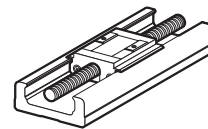

B: 2 blocks (B type)

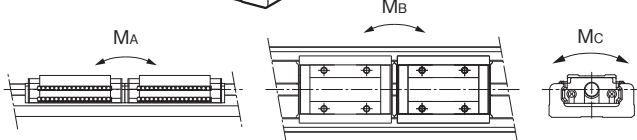
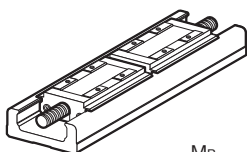

D: 2 short blocks (D type)

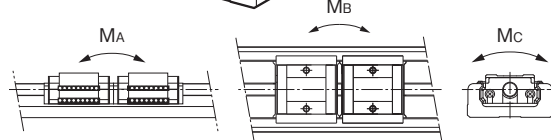
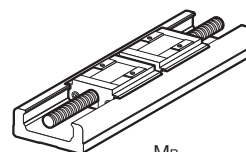

## Static Permissible Moment

The static permissible moment values are for the LM Guide.

Unit: N·m

Model	Static permissible moment		
	M <sub>A</sub>	M <sub>B</sub>	M <sub>C</sub>
KR15-A	12.1	12.1	38
KR15-B	70.3	70.3	76
KR20-A	31	31	83
KR20-B	176	176	165
KR26-A	84	84	208
KR26-B	480	480	416
KR30H-A	166	166	428
KR30H-B	908	908	857
KR30H-C	44	44	214
KR30H-D	319	319	427
KR33-A	166	166	428
KR33-B	908	908	857
KR33-C	44	44	214
KR33-D	319	319	427
KR45H-A	486	486	925
KR45H-B	2,732	2,732	1,850
KR45H-C	130	130	463
KR45H-D	994	994	925
KR46-A	547	547	1,400
KR46-B	2,940	2,940	2,800
KR46-C	149	149	700
KR46-D	1,010	1,010	1,400
KR55-A	870	870	2,280
KR55-B	4,890	4,890	4,570
KR65-A	1,300	1,300	3,920
KR65-B	7,230	7,230	7,840

Notes: 1. The "A," "B," "C," or "D" at the end of the model number indicates the block type.

A: 1 block / B: 2 blocks / C: 1 short block / D: 2 short blocks

2. The value for KR-B/D is with 2 blocks attached (without QZ).

3. Static permissible moment is the maximum permissible moment when the unit is stationary.

## Permissible Moment

This is the moment that can be tolerated when stationary, taking the inner block and sub-table's connectors into consideration.

Unit: N·m

Model	Permissible moment		
	M <sub>A</sub>	M <sub>B</sub>	M <sub>C</sub>
KR15-A	10 (5)	5 (5)	8 (5)
KR15-B	48 (16)	19 (15)	17 (18)
KR20-A	14 (9)	7 (8)	13 (13)
KR20-B	67 (39)	27 (32)	26 (27)
KR26-A	35 (31)	18 (17)	29 (30)
KR26-B	151 (154)	67 (47)	59 (60)
KR30H-A	51 (32)	33 (32)	51 (46)
KR30H-B	256 (256)	128 (90)	103 (103)
KR30H-C	24 (10)	11 (14)	25 (20)
KR30H-D	84 (84)	45 (36)	51 (51)
KR33-A	51 (53)	33 (34)	51 (53)
KR33-B	261 (271)	130 (93)	103 (107)
KR33-C	7 (7)	11 (14)	25 (26)
KR33-D	86 (90)	46 (38)	51 (53)
KR45H-A	105 (34)	70 (63)	98 (31)
KR45H-B	495 (159)	262 (179)	197 (63)
KR45H-C	49 (16)	23 (28)	49 (15)
KR45H-D	161 (52)	91 (71)	98 (31)
KR46-A	105 (34)	72 (68)	105 (34)
KR46-B	504 (165)	310 (188)	211 (69)
KR46-C	15 (18)	29 (30)	52 (17)
KR46-D	166 (54)	95 (76)	105 (34)
KR55-A	170 (169)	141 (212)	170 (169)
KR55-B	872 (863)	553 (686)	341 (338)
KR65-A	349 (170)	306 (316)	349 (326)
KR65-B	1,441 (988)	1,015 (845)	698 (653)

Notes: 4. The "A," "B," "C," or "D" at the end of the model number indicates the block type.

A: 1 block / B: 2 blocks / C: 1 short block / D: 2 short blocks

5. The value for KR-B/D is with 2 blocks attached (without QZ).

6. Values in parentheses are with a cover or bellows.

## Service Life

The KR is composed of an LM Guide, ball screw, and support bearing. The service life of each structure can be calculated using the basic dynamic load rating described in the "Load Rating" table on p. 171.

### LM Guide

#### Nominal Life

$$L_{10} = \left( \frac{C}{P_C} \right)^3 \times 50$$

$L_{10}$ : Nominal life (km)

(The nominal life is the total travel distance that 90% of a group of LM Guide units can achieve without flaking after individually running under the same conditions.)

C: Basic dynamic load rating (N)

$P_C$ : Calculated load (N)

- If a moment will be applied, multiply the applied moment by the equivalent factor listed in the "Equivalent Moment Factors (K)" table on p. 174 to calculate the equivalent load.

$$P_m = K \cdot M$$

$P_m$ : Equivalent load (per block) (N)

K: Equivalent moment factor (see the "Equivalent Moment Factors (K)" table)

M: Applied moment (N·mm)

(If planning to use the product with a wide block span, contact THK.)

- If moment  $M_C$  is applied with KR-B/D

$$P_m = \frac{K_C \cdot M_C}{2}$$

- If a radial load (P) and a moment are simultaneously applied to the KR:

$$P_E = P_m + P$$

$P_E$ : Total equivalent radial load (N)

Perform a nominal life calculation using the above data. (KRF)

#### Service Life Time

$$L_h = \frac{L_{10} \times 10^6}{2 \cdot \ell_s \cdot n_1 \times 60}$$

Once the nominal life ( $L_{10}$ ) has been obtained, the service life time can be obtained using the following formula if the stroke length and the cycles per minute are constant.

$L_h$ : Service life time (h)

$\ell_s$ : Stroke length (mm)

$n_1$ : Cycles per minute ( $\text{min}^{-1}$ )

### Ball Screw and Bearing Unit (Fixed Side)

#### Nominal Life

$$L_{10} = \left( \frac{C_a}{F_a} \right)^3 \times 10^6$$

$L_{10}$ : Nominal life (rev.)

(The nominal life is the total rotations that 90% of a group of ball screw (bearing) units can achieve without flaking after individually running under the same conditions.)

$C_a$ : Basic dynamic load rating (N)

$F_a$ : Axial load (N)

#### Service Life Time

$$L_h = \frac{L_{10} \cdot \ell}{2 \cdot \ell_s \cdot n_1 \times 60}$$

Once the nominal life ( $L_{10}$ ) has been obtained, the service life time can be obtained using the following formula if the stroke length and the cycles per minute are constant.

$L_h$ : Service life time (h)

$\ell_s$ : Stroke length (mm)

$n_1$ : Cycles per minute ( $\text{min}^{-1}$ )

$\ell$ : Ball screw lead (mm)

### $f_c$ : Contact Factor

When using 2 blocks with KR-B/D, multiply the basic load rating by the contact factor from the table on the right.

Contact Factors ( $f_c$ )

Block type	Contact factor ( $f_c$ )
KR-B	0.81
KR-D	

### $f_w$ : Load Factor

In general, reciprocating machines tend to experience vibrations or impacts during operation, and it is difficult to accurately determine the vibrations generated during high-speed operation and impacts during frequent starts and stops. Therefore, when speed and impacts have a significant influence, divide the basic dynamic load rating (C) by the corresponding load factor, which has been empirically obtained.

Load Factor ( $f_w$ )

Vibrations/impacts	Speed (V)	Load coefficient ( $f_w$ )
Very low	Under very low speeds $V \leq 0.25$ m/s	1 to 1.2
Low	Under low speeds $0.25$ m/s $< V \leq 1$ m/s	1.2 to 1.5
Medium	Under medium speeds $1$ m/s $< V \leq 2$ m/s	1.5 to 2
High	Under high speeds $V > 2$ m/s	2 to 3.5

### K: Equivalent Moment Factor (LM Guide)

When running while bearing a load, multiply the equivalent moment factor shown in the table below by the moment value to calculate the load, because the load distribution of the LM Guide will be greater locally.  $K_A$ ,  $K_B$ , and  $K_C$  show the equivalent moment factors for directions  $M_A$ ,  $M_B$ , and  $M_C$ .

Equivalent Moment Factors (K)

Model	$K_A$	$K_B$	$K_C$
KR15-A	$3.2 \times 10^{-1}$	$3.2 \times 10^{-1}$	$9.09 \times 10^{-2}$
KR15-B	$5.96 \times 10^{-2}$	$5.96 \times 10^{-2}$	$9.09 \times 10^{-2}$
KR20-A	$2.4 \times 10^{-1}$	$2.4 \times 10^{-1}$	$7.69 \times 10^{-2}$
KR20-B	$4.26 \times 10^{-2}$	$4.26 \times 10^{-2}$	$7.69 \times 10^{-2}$
KR26-A	$1.73 \times 10^{-1}$	$1.73 \times 10^{-1}$	$5.88 \times 10^{-2}$
KR26-B	$3.06 \times 10^{-2}$	$3.06 \times 10^{-2}$	$5.88 \times 10^{-2}$
KR30H-A	$1.51 \times 10^{-1}$	$1.51 \times 10^{-1}$	$4.78 \times 10^{-2}$
KR30H-B	$2.76 \times 10^{-2}$	$2.76 \times 10^{-2}$	$4.78 \times 10^{-2}$
KR30H-C	$2.77 \times 10^{-1}$	$2.77 \times 10^{-1}$	$4.78 \times 10^{-2}$
KR30H-D	$3.99 \times 10^{-2}$	$3.99 \times 10^{-2}$	$4.78 \times 10^{-2}$
KR33-A	$1.51 \times 10^{-1}$	$1.51 \times 10^{-1}$	$4.93 \times 10^{-2}$
KR33-B	$2.57 \times 10^{-2}$	$2.57 \times 10^{-2}$	$4.93 \times 10^{-2}$
KR33-C	$2.77 \times 10^{-1}$	$2.77 \times 10^{-1}$	$4.93 \times 10^{-2}$
KR33-D	$3.55 \times 10^{-2}$	$3.55 \times 10^{-2}$	$4.93 \times 10^{-2}$
KR45H-A	$9.83 \times 10^{-2}$	$9.83 \times 10^{-2}$	$3.45 \times 10^{-2}$
KR45H-B	$1.87 \times 10^{-2}$	$1.87 \times 10^{-2}$	$3.45 \times 10^{-2}$
KR45H-C	$1.83 \times 10^{-1}$	$1.83 \times 10^{-1}$	$3.45 \times 10^{-2}$
KR45H-D	$2.81 \times 10^{-2}$	$2.81 \times 10^{-2}$	$3.45 \times 10^{-2}$
KR46-A	$1.01 \times 10^{-1}$	$1.01 \times 10^{-1}$	$3.38 \times 10^{-2}$
KR46-B	$1.78 \times 10^{-2}$	$1.78 \times 10^{-2}$	$3.38 \times 10^{-2}$
KR46-C	$1.85 \times 10^{-1}$	$1.85 \times 10^{-1}$	$3.38 \times 10^{-2}$
KR46-D	$2.5 \times 10^{-2}$	$2.5 \times 10^{-2}$	$3.38 \times 10^{-2}$
KR55-A	$8.63 \times 10^{-2}$	$8.63 \times 10^{-2}$	$2.83 \times 10^{-2}$
KR55-B	$1.53 \times 10^{-2}$	$1.53 \times 10^{-2}$	$2.83 \times 10^{-2}$
KR65-A	$7.55 \times 10^{-2}$	$7.55 \times 10^{-2}$	$2.14 \times 10^{-2}$
KR65-B	$1.35 \times 10^{-2}$	$1.35 \times 10^{-2}$	$2.14 \times 10^{-2}$

$K_A$ : Equivalent moment factor in the  $M_A$  direction.

$K_B$ : Equivalent moment factor in the  $M_B$  direction.

$K_C$ : Equivalent moment factor in the  $M_C$  direction.

Note: The value for KR-B/D is with 2 blocks attached.

## Accuracy Standards

### Positioning Repeatability

A positioning operation is performed to arrive at a given arbitrary point, the stop position is measured, and the operation is repeated seven times from the same direction to determine half the difference between the largest and smallest values. The same test is conducted at three points: the middle of the stroke and both the approximate maximum and minimum positions of travel. The positioning repeatability is expressed as the maximum difference among the three measurements divided by 2 with a "±" sign.

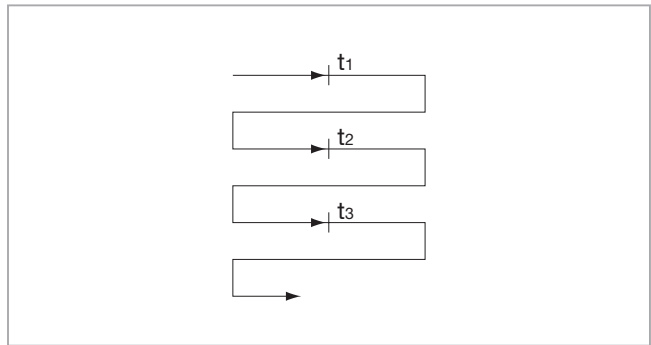

### Positioning Accuracy

With the maximum stroke as reference length, the maximum error between the command value and the actual travel distance from the stroke start position is displayed as an absolute value.

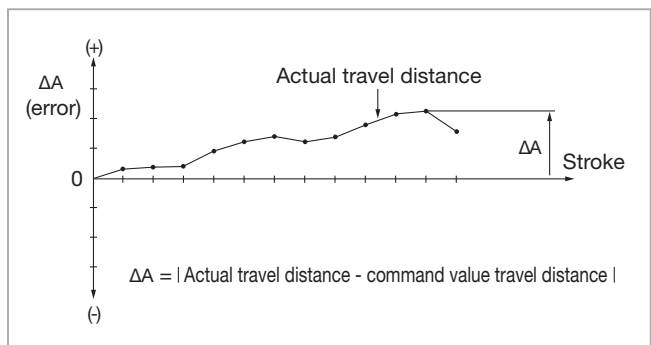

### Running Parallelism (Vertical Direction)

A straightedge is positioned on a surface plate with the KR mounted and the entire range of block movement is measured with a test indicator, taking the maximum difference in readings along the travel distance as the measured value.

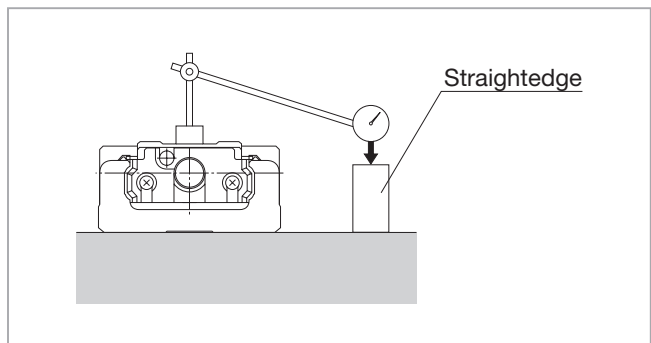

### Backlash

Using as a reference the test indicator reading with feeding applied to the block to move it slightly, a load is applied to the block from the same direction (table feed direction) in this state, without using the feed mechanism, and then the difference between the reference when opened and the return value is taken as the measured value. This measurement is made at the center of the travel distance and at each of the two ends; the largest of the obtained values is set as the measurement value.

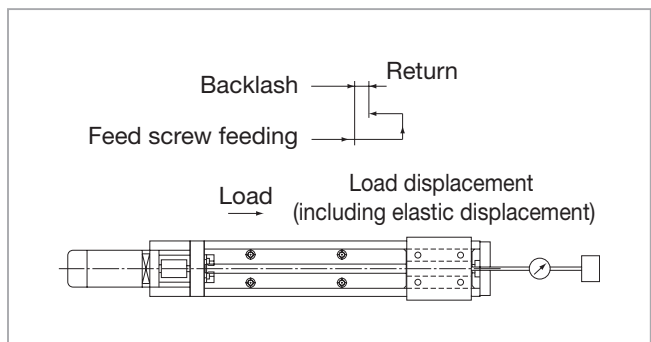

## Normal Grade (No Symbol)

Unit: mm

Model	Stroke <sup>1</sup>	Outer rail length	Positioning repeatability	Positioning accuracy	Running parallelism (vertical direction)	Backlash	Starting torque (N·cm)
KR20	30	100	±0.01	Not specified	Not specified	0.015	0.5
	80	150					
	130	200					
KR26	60	150	±0.01	Not specified	Not specified	0.015	1.5
	110	200					
	160	250					
KR30H	210	300	±0.01	Not specified	Not specified	0.02	7
	50	150					
	100	200					
	200	300					
	300	400					
KR33	400	500	±0.01	Not specified	Not specified	0.02	7
	500	600					
	600	700					
	50	150					
	100	200					
	200	300					
KR45H	300	400	±0.01	Not specified	Not specified	0.02	10
	400	500					
	500	600					
	600	700					
	700	800					
	800	900					
KR46	190	340	±0.01	Not specified	Not specified	0.02	10
	290	440					
	390	540					
	490	640					
	590	740					
	690	840					
KR55	790	940	±0.01	Not specified	Not specified	0.05	12
	800	980					
	900	1,080					
	1,000	1,180					
	1,100	1,280					
KR65	1,200	1,380	±0.01	Not specified	Not specified	0.05	12
	790	980					
	990	1,180					
	1,190	1,380					
	1,490	1,680	±0.012				15

<sup>1</sup> Stroke with 1 block (A type: Without QZ).

Notes: 1. Accuracy standard evaluation method in accordance with THK standards.

2. Measured using a motor for inspection. With motor wrap specifications, measurements are not made in the completed motor wrap state.

3. The starting torque refers to the values when the below greases are used.

Models KR20, KR26: THK AFA Grease

Models KR30H, KR33, KR45H, KR46, KR55, KR65: THK AFB-LF Grease

4. The starting torque may exceed standards if using vacuum grease, clean room grease, or other high-viscosity greases, so care should be taken when selecting a motor.

5. Contact THK for accuracy higher than the standard outer rail length.

6. KR15 is available only as high accuracy grade (H) or precision grade (P).

# Accuracy Standards

## High Accuracy Grade (H)

Unit: mm

Model	Stroke <sup>1</sup>	Outer rail length	Positioning repeatability	Positioning accuracy	Running parallelism (vertical direction)	Backlash	Starting torque (N·cm)
KR15	25	75	±0.004	0.04	0.02	0.01	0.4
	50	100					
	75	125					
	100	150					
	125	175					
KR20	150	200	±0.004	0.06	0.025	0.01	0.5
	30	100					
	80	150					
KR26	130	200	±0.004	0.04	0.025	0.01	1.5
	60	150					
	110	200					
	160	250					
	210	300					
KR30H	50	150	±0.005	0.06	0.02	0.01	7
	100	200		0.08			
	200	300					
	300	400					
	400	500					
500	600						
KR33	50	150	±0.005	0.06	0.02	0.01	7
	100	200					
	200	300					
	300	400		0.1	0.035		
	400	500					
	500	600					
	600	700					
KR45H	200	340	±0.005	0.06	0.03	0.01	10
	300	440					
	400	540					
	500	640		0.12	0.04		
	600	740					
	700	840					
	800	940					
KR46	190	340	±0.005	0.05	0.03	0.01	10
	290	440					
	390	540					
	490	640		0.12	0.04		
	590	740					
	690	840					
	790	940					
KR55	800	980	±0.005	0.18	0.05	0.05	12
	900	1,080		0.25			
	1,000	1,180					
	1,100	1,280					
	1,200	1,380					
KR65	790	980	±0.008	0.18	0.05	0.05	12
	990	1,180		0.2			
	1,190	1,380					
	1,390	1,580					
	1,490	1,680		0.28	0.055		

<sup>1</sup> Stroke with 1 block (A type: Without QZ).

Notes: 1. Accuracy standard evaluation method in accordance with THK standards.

2. Measured using a motor for inspection. With motor wrap specifications, measurements are not made in the completed motor wrap state.

3. The starting torque refers to the values when the below greases are used.

Model KR15: THK AFF Grease

Models KR20, KR26: THK AFA Grease

Models KR30H, KR33, KR45H, KR46, KR55, KR65: THK AFB-LF Grease

4. The starting torque may exceed standards if using vacuum grease, clean room grease, or other high-viscosity greases, so care should be taken when selecting a motor.

5. Contact THK for accuracy higher than the standard outer rail length.

## Precision Grade (P)

Unit: mm

Model	Stroke <sup>1</sup>	Outer rail length	Positioning repeatability	Positioning accuracy	Running parallelism (vertical direction)	Backlash	Starting torque (N·cm)
KR15	25	75	±0.003	0.02	0.01	0.002	0.8
	50	100					
	75	125					
	100	150					
	125	175					
	150	200					
KR20	30	100	±0.003	0.02	0.01	0.003	1.2
	80	150					
	130	200					
KR26	60	150	±0.003	0.02	0.01	0.003	4
	110	200					
	160	250					
	210	300					
KR30H	50	150	±0.003	0.02	0.01	0.003	15
	100	200					
	200	300					
	300	400					
	400	500					
	500	600					
KR33	50	150	±0.003	0.02	0.01	0.003	15
	100	200					
	200	300					
	300	400					
	400	500					
	500	600					
	600	700					
KR45H	200	340	±0.003	0.025	0.015	0.003	15
	300	440					
	400	540					
	500	640					
	600	740	±0.005	0.03	0.02	17	
	700	840					
	800	940					
KR46	190	340	±0.003	0.025	0.015	0.003	15
	290	440					
	390	540					
	490	640					
	590	740	±0.005	0.03	0.02	17	
	690	840					
	790	940					
KR55	800	980	±0.005	0.035	0.025	0.003	17
	900	1,080		0.04	0.03		
	1,000	1,180					
KR65	790	980	±0.005	0.035	0.025	0.005	20
	990	1,180					
	1,190	1,380					

<sup>1</sup> Stroke with 1 block (A type: Without QZ).

Notes: 1. Accuracy standard evaluation method in accordance with THK standards.

2. Measured using a motor for inspection. With motor wrap specifications, measurements are not made in the completed motor wrap state.

3. The starting torque refers to the values when the below greases are used.

Model KR15: THK AFF Grease

Models KR20, KR26: THK AFA Grease

Models KR30H, KR33, KR45H, KR46, KR55, KR65: THK AFB-LF Grease

4. The starting torque may exceed standards if using vacuum grease, clean room grease, or other high-viscosity greases, so care should be taken when selecting a motor.

5. Contact THK for accuracy higher than the standard outer rail length.

## Seals

End seals and side seals are attached as standard for dust-proofing.

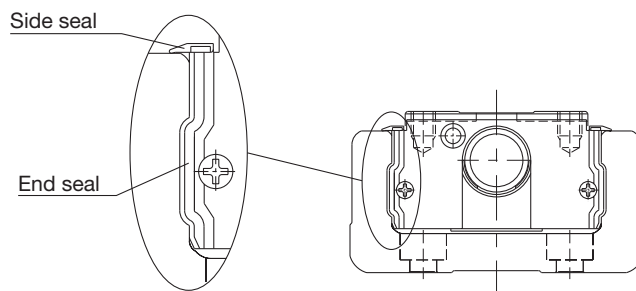

## Maximum Resistance Value

The following table shows the maximum resistance values for each model.

Units: N

Model	Maximum resistance value
KR15	0.9
KR20	1.2
KR26	1.4
KR30H	3.5
KR33	3.4
KR45H	5.1
KR46	5
KR55	8.8
KR65	10.1

## Standard Grease

The following table shows the standard grease and grease nipple used.

Model	Standard grease	Grease nipple used
KR15	THK AFF Grease	-
KR20	THK AFA Grease	PB107
KR26	THK AFA Grease	PB107
KR30H	THK AFB-LF Grease	PB107
KR33	THK AFB-LF Grease	PB107
KR45H	THK AFB-LF Grease	A-M6F
KR46	THK AFB-LF Grease	A-M6F
KR55	THK AFB-LF Grease	A-M6F
KR65	THK AFB-LF Grease	A-M6F





## Precautions on Use

### How to Use this Product

- This product must not be used for devices or systems that are utilized under situations that may affect human life.
- Be sure to contact THK in advance if you are considering using this product for special applications, such as with devices or systems relating to passenger vehicles, medicine, aerospace, nuclear power, or electric power.

### Products with Rotary Motor Drives

#### Handling

- Please contact THK when using the product in special environments such as locations exposed to constant vibrations, clean rooms, vacuums, and low/high temperatures.
- Tilting the table or the outer rail may cause them to fall due to their own weight.

#### Safety Precautions

- Carefully read JIS B8433 "Manipulating Industrial Robots - Safety" and the Japanese Ministry of Health, Labour and Welfare's "Ordinance on Industrial Safety and Health" before working with the product, and follow the guidance within.
- Carefully read the user manual, gain a sufficient understanding of its contents, and be sure to follow the safety precautions.
- When installing, adjusting, inspecting, or performing maintenance on the main actuator unit and connected peripherals, be sure to remove all power plugs from their outlets, and prepare a lock or safety plug to prevent anyone else from turning on the power. Additionally, place a sign in a visible location to notify others that work is being performed.
- Do not touch any moving parts of the actuator while it is energized. In addition, do not enter the operating range of this product while it is in operation or in an operable state.
- If performing a task involving multiple people, confirm how to perform the work, what signals will be used, and how to handle problems before beginning, and assign another person to monitor the work.
- Do not carelessly disassemble this product. Otherwise, it may cause foreign material ingress or decrease the accuracy.
- Take care not to drop or strike this product. Otherwise, it may cause injury or damage the unit. Even if there is no outward indication of damage, a sudden impact could prevent the unit from functioning properly.
- Using this product in excess of the permissible rotational speed may damage the components or cause an accident. Be sure to use the product within the specified rotational speed designated by THK.
- Prevent foreign materials such as cutting chips from entering the product. Otherwise, it may damage the ball circulation components or result in a loss of functionality.
- If using the product in an environment where coolant may get inside, contact THK.
- Install shock absorbers or another impact-absorbing mechanism if there is a risk that the slider may strike the stoppers mounted on both ends of the range of motion. The stoppers are not intended to absorb the impact from sliders. Impacts to the stoppers during operation may lead to damage or accidents.
- Using this product in excess of the torque limit may damage the components or cause an accident.
- Do not set the torque control parameter higher than the torque limit.
- The motor wrap type does not have a safety device for if the timing belt breaks. For your safety, please install a safety device next to the equipment.
- Some models of this product are heavy, with the main unit of this product weighing in excess of 20 kg. Use appropriate transportation equipment and take safety precautions to avoid injury or damage when transporting or installing the product.
- In applications where this product will be moved or transferred, the conditions of use may cause inertia from the motor's mass to result in damage to the motor attachment (Housing A) or other parts. Please contact THK before use.

#### Operating Environment

- Indoors, ambient temperature between 0°C to 40°C, and ambient humidity of 80% RH or less (no freezing or condensation)
- A location with no corrosive or flammable gas
- A location where vibrations or impacts are not transmitted to the main unit
- A location where electrically conductive particles such as steel dust, dust, oil mist, cutting oil, water content, salt content, or organic solvents will not be present in the air
- A location not exposed to direct sunlight or radiant heat
- A location where no strong electric fields or powerful magnetic fields are generated
- A location where inspections and cleanings can easily be performed
- When using the product in locations exposed to constant vibrations or in special environments such as in vacuums or low/high temperatures, contact THK.

#### Actuator Mounting Surface

- Prepare a flat surface that has been machined or possesses an equivalent level of accuracy. Some products have required degrees of flatness.
- Be sure to mount the product on a sufficiently rigid base.

#### Lubrication

- The actuator must be lubricated in order for it to demonstrate its full performance. Insufficient lubrication may increase wear on the rolling elements and lead to premature damage.
- Do not mix lubricants with different properties. Please be aware that the applied lubricant will differ depending on the product.
- Contact THK if a special lubricant will be used.
- As a general guideline, the greasing interval should be every 100 km. However, this will vary depending on the operating conditions, so we recommend determining the greasing interval based on the initial inspection.
- Contact THK if the product will be used in a special environment such as a location with constant vibrations, a vacuum, high/low temperatures, or a clean room, as it may not be possible to use the regular lubricant.
- Contact THK if oil lubricant will be used.
- Thoroughly wipe off anti-rust oil and feed lubricant before using the product.

#### Storage

- When storing the actuator, enclose it in a package designated by THK and store it in a horizontal orientation while avoiding high temperatures, low temperatures, and high humidity.
- Avoid storing control devices in an environment with high/low temperatures or high humidity.

#### Disposal

- The product should be treated as industrial waste and disposed of appropriately.

## Other Recommended Products

### Caged Ball LM Guide Actuator

#### SKR

- Modularized structure reduces number of components and both design and assembly time
- Caged ball effect gives long life and long-term maintenance-free operation
- Optimal for high-precision positioning and orthogonal-axis designs



### LM Guide Actuator with Large-Diameter Ball Screw

#### KSF

##### Open Cover/Top Cover/Fully Enclosed

- Large-diameter ball screw enables high-speed and high-acceleration operations
- 3 types of cover options to choose from to suit the application
- Supports long strokes up to 1,500 mm

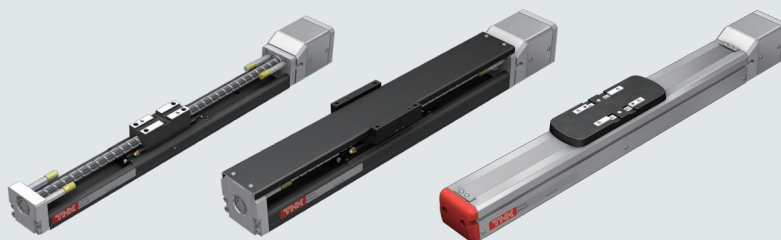

## LM Guide Actuator KR

- **LM Guide and Caged Ball**  are registered trademarks of THK CO., LTD.
- The actual products may differ from the illustrations and photographs in this catalog.
- Outward appearances and specifications are subject to change without notice for the purpose of improvement. Please consult with THK before using.
- Although great care has been taken in the production of this catalog, THK will not take any responsibility for damages resulting from typographical errors or omissions.
- For exports of our products and technologies and sales for export, our basic policy is to comply with the Foreign Exchange and Foreign Trade Act and other laws and regulations. Please consult us in advance if you want to export our products by the piece.

All rights reserved.

# THK CO., LTD.

Global Headquarters 2-12-10 Shibaura, Minato-ku, Tokyo 108-8506 Japan

International Sales Department Phone: +81-3-5730-3860

[www.thk.com](http://www.thk.com)