

BNK0401-3 Shaft Diameter: 4; Lead: 1

DN value

70,000

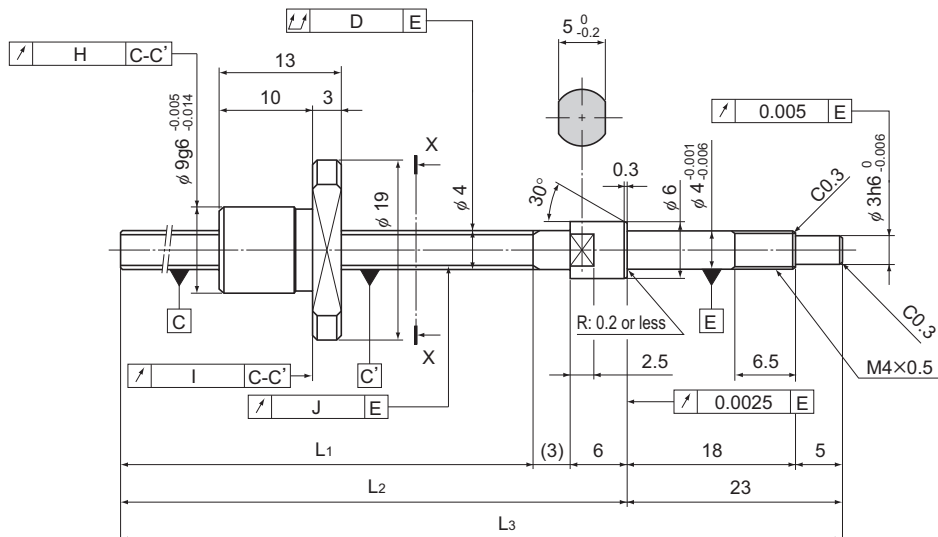

Model No.	Stroke	Screw shaft length		
		L ₁	L ₂	L ₃
BNK 0401-3G0+77LC3Y	20	45	54	77
BNK 0401-3G0+77LC5Y				
BNK 0401-3G2+77LC7Y				
BNK 0401-3G0+97LC3Y	40	65	74	97
BNK 0401-3G0+97LC5Y				
BNK 0401-3G2+97LC7Y				
BNK 0401-3G0+127LC3Y	70	95	104	127
BNK 0401-3G0+127LC5Y				
BNK 0401-3G2+127LC7Y				

Notes: A stainless steel type is also available for Model BNK0401. When placing an order, add symbol "M" to the end of the model number.

(Example) BNK0401-3G0+77LC3Y M

Symbol for stainless steel type

For accuracy grades C3 and C5, GT clearance is also available as standard.

Positioning Ball Screw

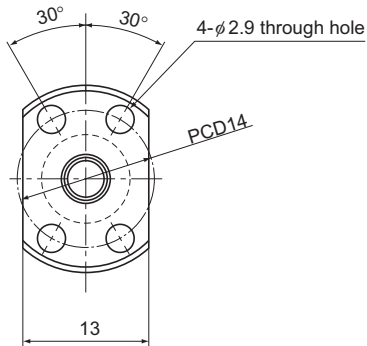

X-X arrow view

Ball screw specifications			
Lead (mm)	1		
BCD (mm)	4.15		
Thread minor diameter (mm)	3.4		
Threading direction, No. of threaded grooves	Rightward, 1		
No. of circuits	1 turn × 3 rows		
Clearance symbol	G0	GT	G2
Axial clearance (mm)	0	0.005 or less	0.02 or less
Basic dynamic load rating C_a (kN)	0.29	0.29	0.29
Basic static load rating C_{0a} (kN)	0.42	0.42	0.42
Preload torque (N·m)	to 9.8×10^{-3}	—	—
Spacer ball	None	None	None
Rigidity value (N/ μ m)	35		
Circulation method	Deflector		

Unit: mm

	Runout of the screw shaft axis D	Runout of the nut circumference H	Flange mounting surface runout I	Runout of the thread groove surface J	Lead angle accuracy		Nut mass kg	Shaft mass kg/m	Permissible rotational speed min ⁻¹
					Representative travel distance error	Fluctuation			
	0.015	0.009	0.008	0.008	± 0.008	0.008	0.01	0.07	3,500
	0.025	0.012	0.01	0.01	± 0.018	0.018	0.01	0.07	3,500
	0.035	0.02	0.014	0.014	Travel distance: $\pm 0.05/300$		0.01	0.07	3,500
	0.02	0.009	0.008	0.008	± 0.008	0.008	0.01	0.07	3,500
	0.025	0.012	0.01	0.01	± 0.018	0.018	0.01	0.07	3,500
	0.035	0.02	0.014	0.014	Travel distance: $\pm 0.05/300$		0.01	0.07	3,500
	0.025	0.009	0.008	0.008	± 0.008	0.008	0.01	0.07	3,500
	0.035	0.012	0.01	0.01	± 0.018	0.018	0.01	0.07	3,500
	0.05	0.02	0.014	0.014	Travel distance: $\pm 0.05/300$		0.01	0.07	3,500

BNK0501-3 Shaft Diameter: 5; Lead: 1

DN value

70,000

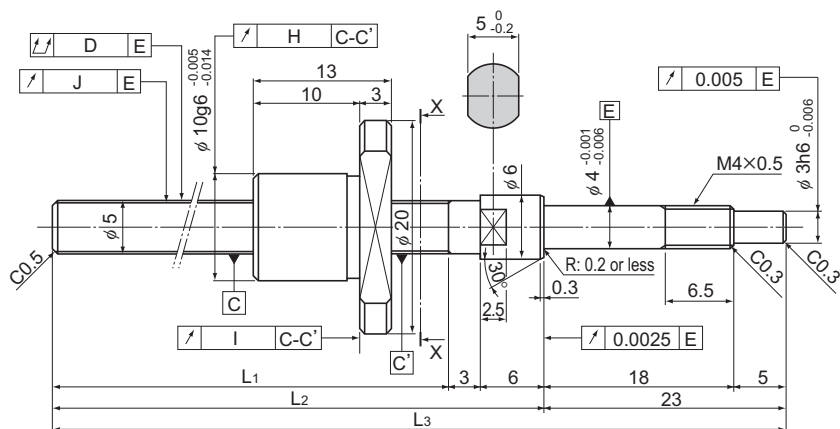

Model No.	Stroke	Screw shaft length		
		L ₁	L ₂	L ₃
BNK 0501-3G0+77LC3Y	20	45	54	77
BNK 0501-3G0+77LC5Y				
BNK 0501-3G2+77LC7Y				
BNK 0501-3G0+97LC3Y	40	65	74	97
BNK 0501-3G0+97LC5Y				
BNK 0501-3G2+97LC7Y				
BNK 0501-3G0+127LC3Y	70	95	104	127
BNK 0501-3G0+127LC5Y				
BNK 0501-3G2+127LC7Y				

Notes: A stainless steel type is also available for Model BNK0501. When placing an order, add symbol "M" to the end of the model number.

(Example) BNK0501-3G0+77LC3Y M

Symbol for stainless steel type

For accuracy grades C3 and C5, GT clearance is also available as standard.

Positioning Ball Screw

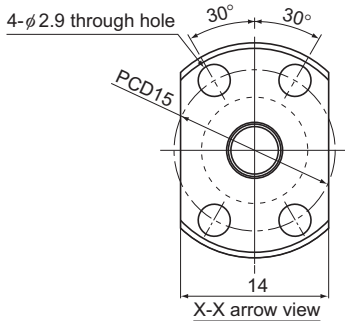

Ball screw specifications			
Lead (mm)	1		
BCD (mm)	5.15		
Thread minor diameter (mm)	4.4		
Threading direction, No. of threaded grooves	Rightward, 1		
No. of circuits	1 turn × 3 rows		
Clearance symbol	G0	GT	G2
Axial clearance (mm)	0	0.005 or less	0.02 or less
Basic dynamic load rating C_a (kN)	0.32	0.32	0.32
Basic static load rating C_{0a} (kN)	0.55	0.55	0.55
Preload torque (N·m)	to 9.8×10^{-3}	—	—
Spacer ball	None	None	None
Rigidity value (N/μm)	47		
Circulation method	Deflector		

Unit: mm

	Runout of the screw shaft axis D	Runout of the nut circumference H	Flange mounting surface runout I	Runout of the thread groove surface J	Lead angle accuracy		Nut mass kg	Shaft mass kg/m	Permissible rotational speed min ⁻¹
					Representative travel distance error	Fluctuation			
	0.015	0.009	0.008	0.008	±0.008	0.008	0.012	0.11	3,500
	0.025	0.012	0.01	0.01	±0.018	0.018	0.012	0.11	3,500
	0.035	0.02	0.014	0.014	Travel distance: ±0.05/300		0.012	0.11	3,500
	0.02	0.009	0.008	0.008	±0.008	0.008	0.012	0.11	3,500
	0.025	0.012	0.01	0.01	±0.018	0.018	0.012	0.11	3,500
	0.035	0.02	0.014	0.014	Travel distance: ±0.05/300		0.012	0.11	3,500
	0.025	0.009	0.008	0.008	±0.008	0.008	0.012	0.11	3,500
	0.035	0.012	0.01	0.01	±0.018	0.018	0.012	0.11	3,500
	0.05	0.02	0.014	0.014	Travel distance: ±0.05/300		0.012	0.11	3,500

BNK0601-3 Shaft Diameter: 6; Lead: 1

DN value

70,000

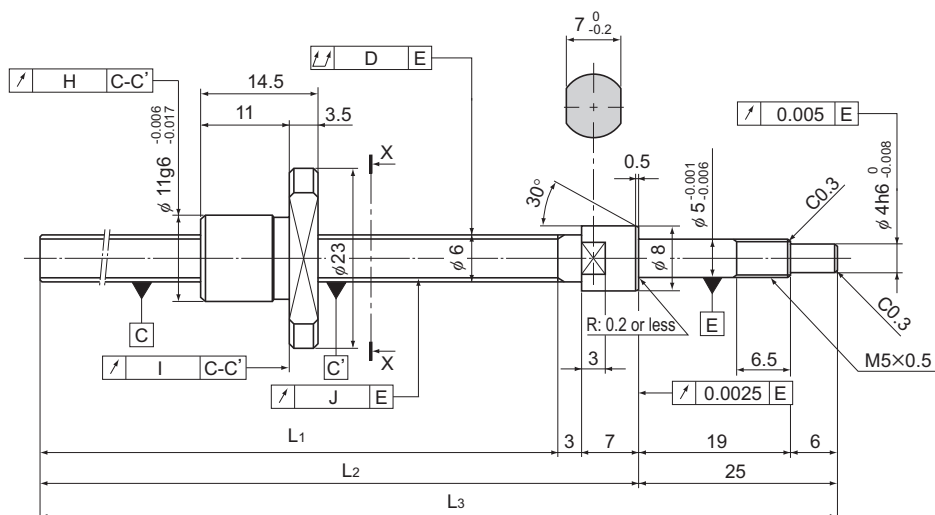

Model No.	Stroke	Screw shaft length		
		L ₁	L ₂	L ₃
BNK 0601-3G0+100LC3Y	40	65	75	100
BNK 0601-3G0+100LC5Y				
BNK 0601-3G2+100LC7Y				
BNK 0601-3G0+130LC3Y	70	95	105	130
BNK 0601-3G0+130LC5Y				
BNK 0601-3G2+130LC7Y				
BNK 0601-3G0+160LC3Y	100	125	135	160
BNK 0601-3G0+160LC5Y				
BNK 0601-3G2+160LC7Y				

Notes: A stainless steel type is also available for Model BNK0601. When placing an order, add symbol "M" to the end of the model number.

(Example) BNK0601-3G0+100LC3Y M

Symbol for stainless steel type

For accuracy grades C3 and C5, GT clearance is also available as standard.

Positioning Ball Screw

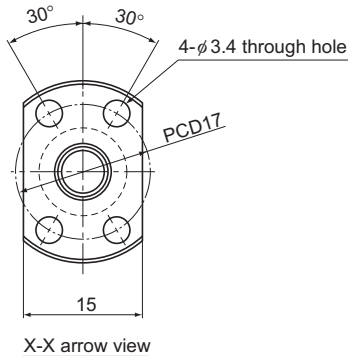

Ball screw specifications			
Lead (mm)	1		
BCD (mm)	6.2		
Thread minor diameter (mm)	5.3		
Threading direction, No. of threaded grooves	Rightward, 1		
No. of circuits	1 turn × 3 rows		
Clearance symbol	G0	GT	G2
Axial clearance (mm)	0	0.005 or less	0.02 or less
Basic dynamic load rating C_a (kN)	0.54	0.54	0.54
Basic static load rating C_{0a} (kN)	0.94	0.94	0.94
Preload torque (N·m)	to 1.3×10^2	—	—
Spacer ball	None	None	None
Rigidity value (N/μm)	60		
Circulation method	Deflector		

Unit: mm

	Runout of the screw shaft axis D	Runout of the nut circumference H	Flange mounting surface runout I	Runout of the thread groove surface J	Lead angle accuracy		Nut mass kg	Shaft mass kg/m	Permissible rotational speed min ⁻¹
					Representative travel distance error	Fluctuation			
	0.015	0.009	0.008	0.008	±0.008	0.008	0.017	0.14	3,500
	0.025	0.012	0.01	0.01	±0.018	0.018	0.017	0.14	3,500
	0.035	0.02	0.014	0.014	Travel distance: ±0.05/300		0.017	0.14	3,500
	0.02	0.009	0.008	0.008	±0.008	0.008	0.017	0.14	3,500
	0.035	0.012	0.01	0.01	±0.018	0.018	0.017	0.14	3,500
	0.05	0.02	0.014	0.014	Travel distance: ±0.05/300		0.017	0.14	3,500
	0.025	0.009	0.008	0.008	±0.01	0.008	0.017	0.14	3,500
	0.035	0.012	0.01	0.01	±0.02	0.018	0.017	0.14	3,500
	0.05	0.02	0.014	0.014	Travel distance: ±0.05/300		0.017	0.14	3,500

BNK0608-3 Shaft Diameter: 6; Lead: 8

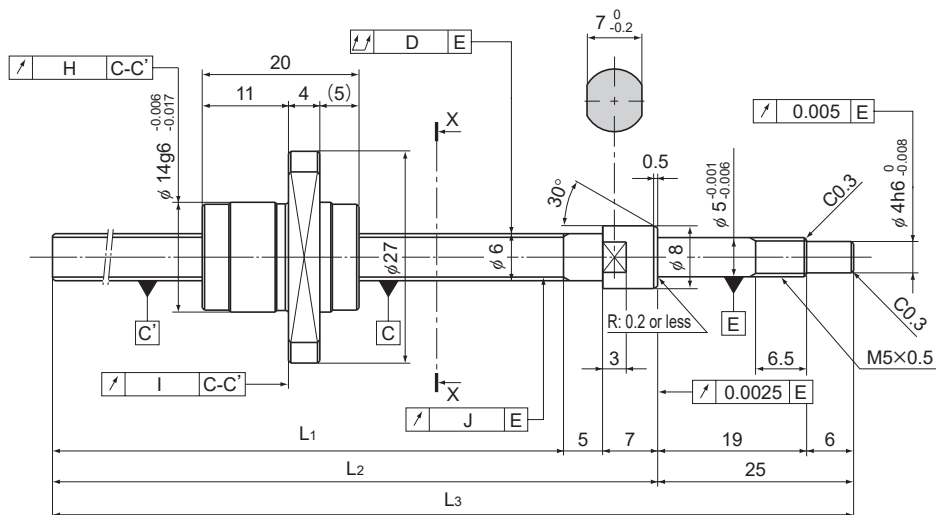

Model No.	Stroke	Screw shaft length		
		L ₁	L ₂	L ₃
BNK 0608-3GT+130LC5Y	70	93	105	130
BNK 0608-3G2+130LC7Y				
BNK 0608-3GT+160LC5Y	100	123	135	160
BNK 0608-3G2+160LC7Y				

Note: For accuracy grade C5, GT clearance is also standardized.

Positioning Ball Screw

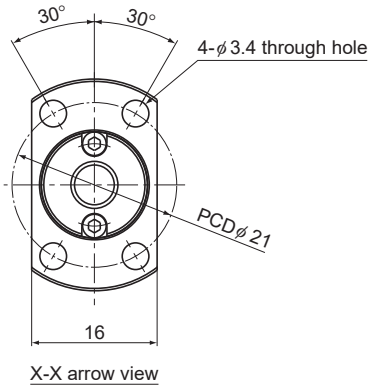

Ball screw specifications		
Lead (mm)	8	
BCD (mm)	6.3	
Thread minor diameter (mm)	5	
Threading direction, No. of threaded grooves	Rightward, 2	
No. of circuits	1.5 turn × 2 rows	
Clearance symbol	GT	G2
Axial clearance (mm)	0.005 or less	0.02 or less
Basic dynamic load rating C_a (kN)	1.32	1.32
Basic static load rating C_{0a} (kN)	2.18	2.18
Preload torque (N·m)	—	—
Spacer ball	None	None
Rigidity value (N/μm)	84	
Circulation method	End cap	

Unit: mm

	Runout of the screw shaft axis D	Runout of the nut circumference H	Flange mounting surface runout I	Runout of the thread groove surface J	Lead angle accuracy		Nut mass kg	Shaft mass kg/m	Permissible rotational speed min ⁻¹
					Representative travel distance error	Fluctuation			
	0.035	0.012	0.01	0.01	±0.018	0.018	0.025	0.14	5,000
	0.05	0.02	0.014	0.014	Travel distance: ±0.05/300		0.025	0.14	5,000
	0.035	0.012	0.01	0.01	±0.02	0.018	0.025	0.14	5,000
	0.05	0.02	0.014	0.014	Travel distance: ±0.05/300		0.025	0.14	5,000

BNK0801-3 Shaft Diameter: 8; Lead: 1

DN value

70,000

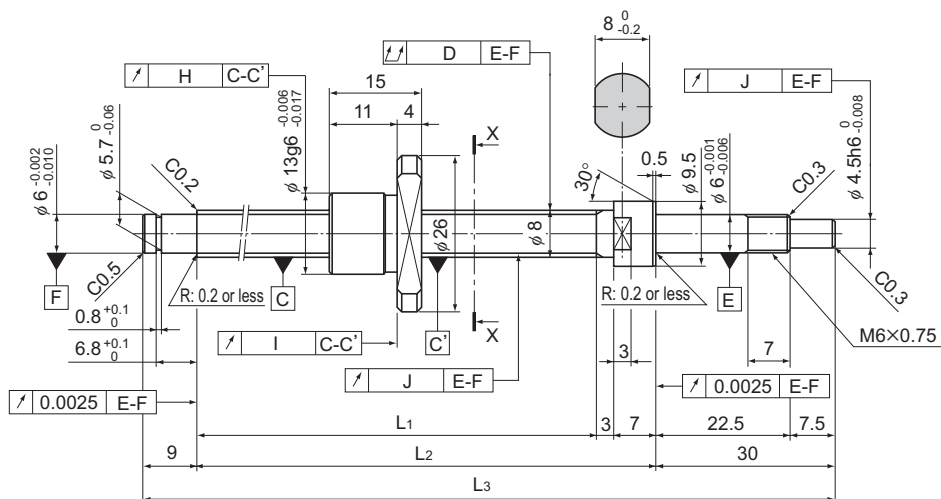

Model No.	Stroke	Screw shaft length		
		L ₁	L ₂	L ₃
BNK 0801-3G0+115LC3Y	40	66	76	115
BNK 0801-3G0+115LC5Y				
BNK 0801-3G2+115LC7Y				
BNK 0801-3G0+145LC3Y	70	96	106	145
BNK 0801-3G0+145LC5Y				
BNK 0801-3G2+145LC7Y				
BNK 0801-3G0+175LC3Y	100	126	136	175
BNK 0801-3G0+175LC5Y				
BNK 0801-3G2+175LC7Y				
BNK 0801-3G0+225LC3Y	150	176	186	225
BNK 0801-3G0+225LC5Y				
BNK 0801-3G2+225LC7Y				

Notes: A stainless steel type is also available for Model BNK0801. When placing an order, add symbol "M" to the end of the model number.

(Example) BNK0801-3G0+115LC3Y M

Symbol for stainless steel type

For accuracy grades C3 and C5, GT clearance is also available as standard.

Positioning Ball Screw

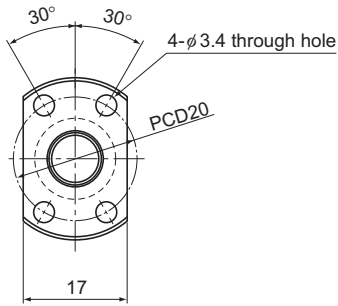

X-X arrow view

Ball screw specifications			
Lead (mm)	1		
BCD (mm)	8.2		
Thread minor diameter (mm)	7.3		
Threading direction, No. of threaded grooves	Rightward, 1		
No. of circuits	1 turn × 3 rows		
Clearance symbol	G0	GT	G2
Axial clearance (mm)	0	0.005 or less	0.02 or less
Basic dynamic load rating C_a (kN)	0.64	0.64	0.64
Basic static load rating C_{0a} (kN)	1.4	1.4	1.4
Preload torque (N·m)	to 1.8×10^2	—	—
Spacer ball	None	None	None
Rigidity value (N/ μ m)	80		
Circulation method	Deflector		

Unit: mm

	Runout of the screw shaft axis D	Runout of the nut circumference H	Flange mounting surface runout I	Runout of the thread groove surface J	Lead angle accuracy		Nut mass kg	Shaft mass kg/m	Permissible rotational speed min ⁻¹
					Representative travel distance error	Fluctuation			
	0.025	0.009	0.008	0.008	±0.008	0.008	0.024	0.29	3,500
	0.025	0.012	0.01	0.01	±0.018	0.018	0.024	0.29	3,500
	0.035	0.02	0.014	0.014	Travel distance: ±0.05/300		0.024	0.29	3,500
	0.03	0.009	0.008	0.008	±0.008	0.008	0.024	0.29	3,500
	0.035	0.012	0.01	0.01	±0.018	0.018	0.024	0.29	3,500
	0.05	0.02	0.014	0.014	Travel distance: ±0.05/300		0.024	0.29	3,500
	0.03	0.009	0.008	0.008	±0.01	0.008	0.024	0.29	3,500
	0.035	0.012	0.01	0.01	±0.02	0.018	0.024	0.29	3,500
	0.05	0.02	0.014	0.014	Travel distance: ±0.05/300		0.024	0.29	3,500
	0.035	0.009	0.008	0.008	±0.01	0.008	0.024	0.29	3,500
	0.05	0.012	0.01	0.01	±0.02	0.018	0.024	0.29	3,500
	0.065	0.02	0.014	0.014	Travel distance: ±0.05/300		0.024	0.29	3,500

BNK0802-3 Shaft Diameter: 8; Lead: 2

DN value

70,000

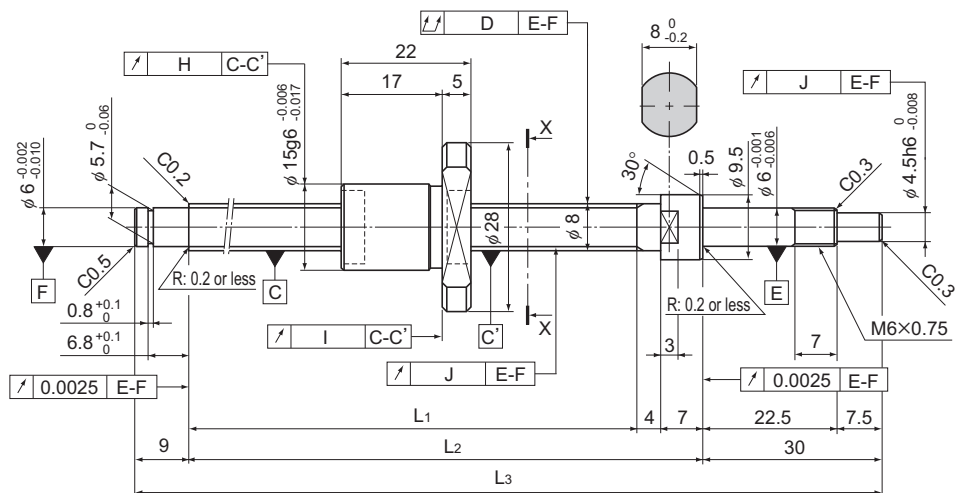

Model No.	Stroke	Screw shaft length		
		L ₁	L ₂	L ₃
BNK 0802-3RRG0+125LC3Y	40	75	86	125
BNK 0802-3RRG0+125LC5Y				
BNK 0802-3RRG2+125LC7Y				
BNK 0802-3RRG0+155LC3Y	70	105	116	155
BNK 0802-3RRG0+155LC5Y				
BNK 0802-3RRG2+155LC7Y				
BNK 0802-3RRG0+185LC3Y	100	135	146	185
BNK 0802-3RRG0+185LC5Y				
BNK 0802-3RRG2+185LC7Y				
BNK 0802-3RRG0+235LC3Y	150	185	196	235
BNK 0802-3RRG0+235LC5Y				
BNK 0802-3RRG2+235LC7Y				

Notes: A stainless steel type is also available for Model BNK0802. When placing an order, add symbol "M" to the end of the model number.

(Example) BNK0802-3RRG0+125LC3Y M

Symbol for stainless steel type

For accuracy grades C3 and C5, GT clearance is also available as standard.

Positioning Ball Screw

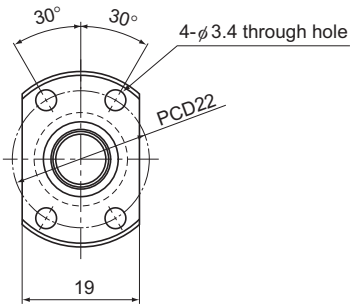

X-X arrow view

Ball screw specifications			
Lead (mm)	2		
BCD (mm)	8.3		
Thread minor diameter (mm)	7		
Threading direction, No. of threaded grooves	Rightward, 1		
No. of circuits	1 turn × 3 rows		
Clearance symbol	G0	GT	G2
Axial clearance (mm)	0	0.005 or less	0.02 or less
Basic dynamic load rating C_a (kN)	1.4	1.4	1.4
Basic static load rating C_{0a} (kN)	2.3	2.3	2.3
Preload torque (N·m)	to 2×10^2	—	—
Spacer ball	None	None	None
Rigidity value (N/μm)	100		
Circulation method	Deflector		

Unit: mm

	Runout of the screw shaft axis D	Runout of the nut circumference H	Flange mounting surface runout I	Runout of the thread groove surface J	Lead angle accuracy		Nut mass kg	Shaft mass kg/m	Permissible rotational speed min ⁻¹
					Representative travel distance error	Fluctuation			
	0.025	0.009	0.008	0.008	±0.008	0.008	0.034	0.27	3,500
	0.025	0.012	0.01	0.01	±0.018	0.018	0.034	0.27	3,500
	0.035	0.02	0.014	0.014	Travel distance: ±0.05/300		0.034	0.27	3,500
	0.03	0.009	0.008	0.008	±0.01	0.008	0.034	0.27	3,500
	0.035	0.012	0.01	0.01	±0.02	0.018	0.034	0.27	3,500
	0.05	0.02	0.014	0.014	Travel distance: ±0.05/300		0.034	0.27	3,500
	0.03	0.009	0.008	0.008	±0.01	0.008	0.034	0.27	3,500
	0.035	0.012	0.01	0.01	±0.02	0.018	0.034	0.27	3,500
	0.05	0.02	0.014	0.014	Travel distance: ±0.05/300		0.034	0.27	3,500
	0.035	0.009	0.008	0.008	±0.01	0.008	0.034	0.27	3,500
	0.05	0.012	0.01	0.01	±0.02	0.018	0.034	0.27	3,500
	0.065	0.02	0.014	0.014	Travel distance: ±0.05/300		0.034	0.27	3,500

BNK0810-3 Shaft Diameter: 8; Lead: 10

DN value

70,000

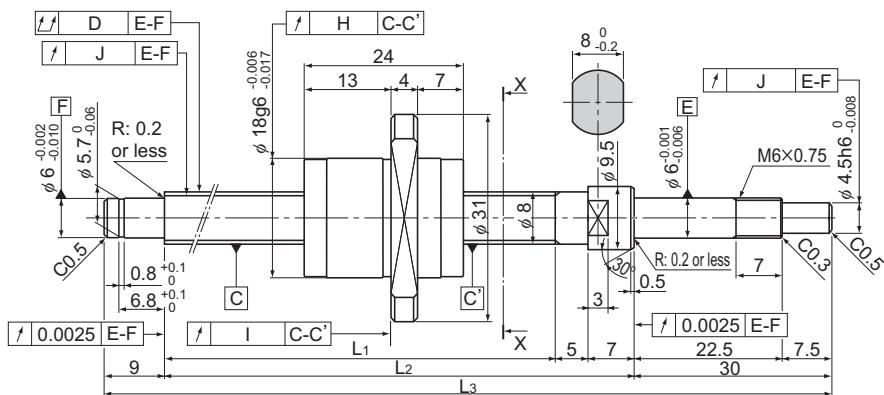

Model No.	Stroke	Screw shaft length		
		L_1	L_2	L_3
BNK 0810-3GT+205LC5Y	100	154	166	205
BNK 0810-3G2+205LC7Y				
BNK 0810-3GT+255LC5Y	150	204	216	255
BNK 0810-3G2+255LC7Y				
BNK 0810-3GT+305LC5Y	200	254	266	305
BNK 0810-3G2+305LC7Y				
BNK 0810-3GT+355LC5Y	250	304	316	355
BNK 0810-3G2+355LC7Y				
BNK 0810-3GT+405LC5Y	300	354	366	405
BNK 0810-3G2+405LC7Y				

Positioning Ball Screw

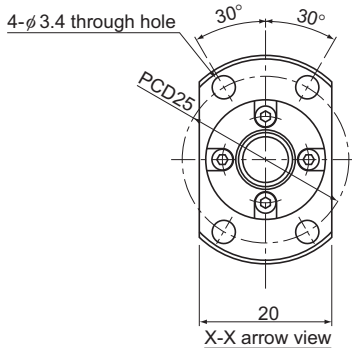

Ball screw specifications		
Lead (mm)	10	
BCD (mm)	8.4	
Thread minor diameter (mm)	6.7	
Threading direction, No. of threaded grooves	Rightward, 2	
No. of circuits	1.5 turns × 2 rows	
Clearance symbol	GT	G2
Axial clearance (mm)	0.005 or less	0.02 or less
Basic dynamic load rating C_a (kN)	2.16	2.16
Basic static load rating C_{0a} (kN)	3.82	3.82
Preload torque (N·m)	—	—
Spacer ball	None	None
Rigidity value (N/μm)	100	
Circulation method	End cap	

Unit: mm

	Runout of the screw shaft axis D	Runout of the nut circumference H	Flange mounting surface runout I	Runout of the thread groove surface J	Lead angle accuracy		Nut mass kg	Shaft mass kg/m	Permissible rotational speed min ⁻¹
					Representative travel distance error	Fluctuation			
	0.05	0.012	0.01	0.01	±0.02	0.018	0.049	0.3	3,500
	0.065	0.02	0.014	0.014	Travel distance: ±0.05/300		0.049	0.3	3,500
	0.05	0.012	0.01	0.01	±0.023	0.018	0.049	0.3	3,500
	0.065	0.02	0.014	0.014	Travel distance: ±0.05/300		0.049	0.3	3,500
	0.05	0.012	0.01	0.01	±0.023	0.018	0.049	0.3	3,500
	0.065	0.02	0.014	0.014	Travel distance: ±0.05/300		0.049	0.3	3,500
	0.06	0.012	0.01	0.01	±0.023	0.018	0.049	0.3	3,500
	0.075	0.02	0.014	0.014	Travel distance: ±0.05/300		0.049	0.3	3,500
	0.07	0.012	0.01	0.01	±0.025	0.018	0.049	0.3	3,500
	0.09	0.02	0.014	0.014	Travel distance: ±0.05/300		0.049	0.3	3,500

BNK1002-3 Shaft Diameter: 10; Lead: 2

DN value

70,000

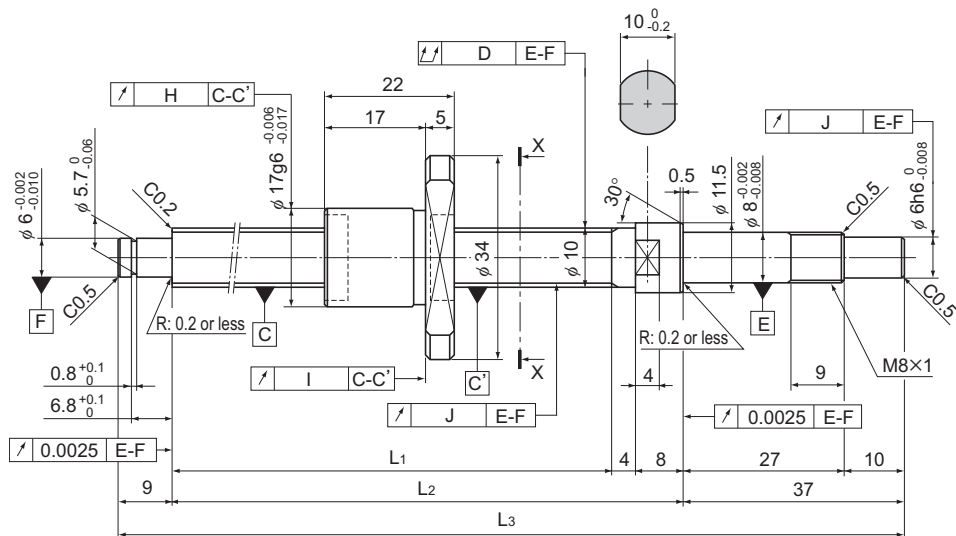

Model No.	Stroke	Screw shaft length		
		L ₁	L ₂	L ₃
BNK 1002-3RRG0+143LC3Y	50	85	97	143
BNK 1002-3RRG0+143LC5Y				
BNK 1002-3RRG2+143LC7Y				
BNK 1002-3RRG0+193LC3Y	100	135	147	193
BNK 1002-3RRG0+193LC5Y				
BNK 1002-3RRG2+193LC7Y				
BNK 1002-3RRG0+243LC3Y	150	185	197	243
BNK 1002-3RRG0+243LC5Y				
BNK 1002-3RRG2+243LC7Y				
BNK 1002-3RRG0+293LC3Y	200	235	247	293
BNK 1002-3RRG0+293LC5Y				
BNK 1002-3RRG2+293LC7Y				

Notes: A stainless steel type is also available for Model BNK1002. When placing an order, add symbol "M" to the end of the model number.

(Example) BNK1002-3RRG0+143LC3Y M

Symbol for stainless steel type

For accuracy grades C3 and C5, GT clearance is also available as standard.

Positioning Ball Screw

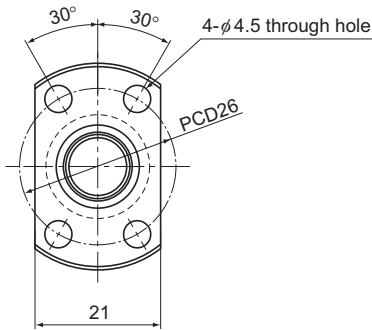

X-X arrow view

Ball screw specifications			
Lead (mm)	2		
BCD (mm)	10.3		
Thread minor diameter (mm)	9		
Threading direction, No. of threaded grooves	Rightward, 1		
No. of circuits	1 turn × 3 rows		
Clearance symbol	G0	GT	G2
Axial clearance (mm)	0	0.005 or less	0.02 or less
Basic dynamic load rating C_a (kN)	1.5	1.5	1.5
Basic static load rating C_{0a} (kN)	2.9	2.9	2.9
Preload torque (N·m)	to 2.5×10^2	—	—
Spacer ball	None	None	None
Rigidity value (N/μm)	100		
Circulation method	Deflector		

Unit: mm

	Runout of the screw shaft axis D	Runout of the nut circumference H	Flange mounting surface runout I	Runout of the thread groove surface J	Lead angle accuracy		Nut mass kg	Shaft mass kg/m	Permissible rotational speed min ⁻¹
					Representative travel distance error	Fluctuation			
	0.02	0.009	0.008	0.007	±0.008	0.008	0.045	0.47	3,500
	0.035	0.012	0.01	0.011	±0.018	0.018	0.045	0.47	3,500
	0.04	0.02	0.014	0.014	Travel distance: ±0.05/300		0.045	0.47	3,500
	0.03	0.009	0.008	0.007	±0.01	0.008	0.045	0.47	3,500
	0.035	0.012	0.01	0.011	±0.02	0.018	0.045	0.47	3,500
	0.04	0.02	0.014	0.014	Travel distance: ±0.05/300		0.045	0.47	3,500
	0.03	0.009	0.008	0.007	±0.01	0.008	0.045	0.47	3,500
	0.04	0.012	0.01	0.011	±0.02	0.018	0.045	0.47	3,500
	0.055	0.02	0.014	0.014	Travel distance: ±0.05/300		0.045	0.47	3,500
	0.03	0.009	0.008	0.007	±0.012	0.008	0.045	0.47	3,500
	0.04	0.012	0.01	0.011	±0.023	0.018	0.045	0.47	3,500
	0.055	0.02	0.014	0.014	Travel distance: ±0.05/300		0.045	0.47	3,500

BNK1004-2.5 Shaft Diameter: 10; Lead: 4

DN value

70,000

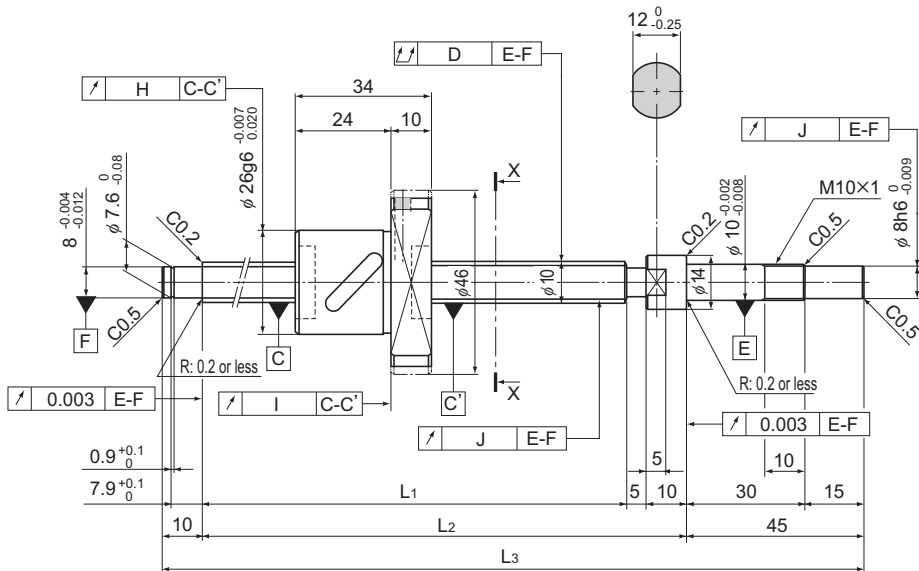

Model No.	Stroke	Screw shaft length		
		L ₁	L ₂	L ₃
BNK 1004-2.5RRG0+180LC3Y	50	110	125	180
BNK 1004-2.5RRG0+180LC5Y				
BNK 1004-2.5RRG2+180LC7Y				
BNK 1004-2.5RRG0+230LC3Y	100	160	175	230
BNK 1004-2.5RRG0+230LC5Y				
BNK 1004-2.5RRG2+230LC7Y				
BNK 1004-2.5RRG0+280LC3Y	150	210	225	280
BNK 1004-2.5RRG0+280LC5Y				
BNK 1004-2.5RRG2+280LC7Y				
BNK 1004-2.5RRG0+330LC3Y	200	260	275	330
BNK 1004-2.5RRG0+330LC5Y				
BNK 1004-2.5RRG2+330LC7Y				
BNK 1004-2.5RRG0+380LC3Y	250	310	325	380
BNK 1004-2.5RRG0+380LC5Y				
BNK 1004-2.5RRG2+380LC7Y				

Note: For accuracy grades C3 and C5, GT clearance is also available as standard.

Positioning Ball Screw

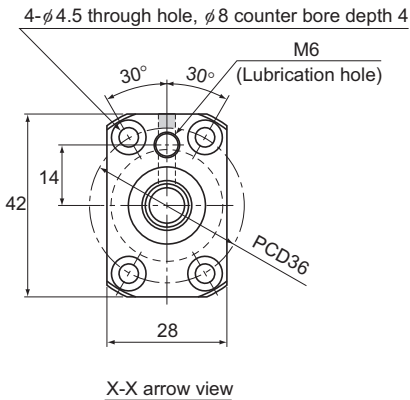

Ball screw specifications			
Lead (mm)	4		
BCD (mm)	10.5		
Thread minor diameter (mm)	7.8		
Threading direction, No. of threaded grooves	Rightward, 1		
No. of circuits	2.5 turns \times 1 row		
Clearance symbol	G0	GT	G2
Axial clearance (mm)	0	0.005 or less	0.02 or less
Basic dynamic load rating C_a (kN)	2.1	3.4	3.4
Basic static load rating C_{0a} (kN)	2.7	5.4	5.4
Preload torque (N·m)	9.8×10^3 to 4.9×10^2	—	—
Spacer ball	1 : 1	None	None
Rigidity value (N/ μ m)	50	100	
Circulation method	Return pipe		

Unit: mm

	Runout of the screw shaft axis D	Runout of the nut circumference H	Flange mounting surface runout I	Runout of the thread groove surface J	Lead angle accuracy		Nut mass kg	Shaft mass kg/m	Permissible rotational speed min ⁻¹
					Representative travel distance error	Fluctuation			
	0.02	0.009	0.008	0.008	± 0.01	0.008	0.15	0.32	5,000
	0.035	0.012	0.01	0.011	± 0.02	0.018	0.15	0.32	5,000
	0.04	0.02	0.014	0.014	Travel distance: $\pm 0.05/300$		0.15	0.32	5,000
	0.03	0.009	0.008	0.008	± 0.01	0.008	0.15	0.32	5,000
	0.04	0.012	0.01	0.011	± 0.02	0.018	0.15	0.32	5,000
	0.055	0.02	0.014	0.014	Travel distance: $\pm 0.05/300$		0.15	0.32	5,000
	0.03	0.009	0.008	0.008	± 0.012	0.008	0.15	0.32	5,000
	0.04	0.012	0.01	0.011	± 0.023	0.018	0.15	0.32	5,000
	0.055	0.02	0.014	0.014	Travel distance: $\pm 0.05/300$		0.15	0.32	5,000
	0.04	0.009	0.008	0.008	± 0.012	0.008	0.15	0.32	5,000
	0.05	0.012	0.01	0.011	± 0.023	0.018	0.15	0.32	5,000
	0.065	0.02	0.014	0.014	Travel distance: $\pm 0.05/300$		0.15	0.32	5,000
	0.04	0.009	0.008	0.008	± 0.012	0.008	0.15	0.32	5,000
	0.05	0.012	0.01	0.011	± 0.023	0.018	0.15	0.32	5,000
	0.065	0.02	0.014	0.014	Travel distance: $\pm 0.05/300$		0.15	0.32	5,000

BNK1010-1.5 Shaft Diameter: 10; Lead: 10

DN value

70,000

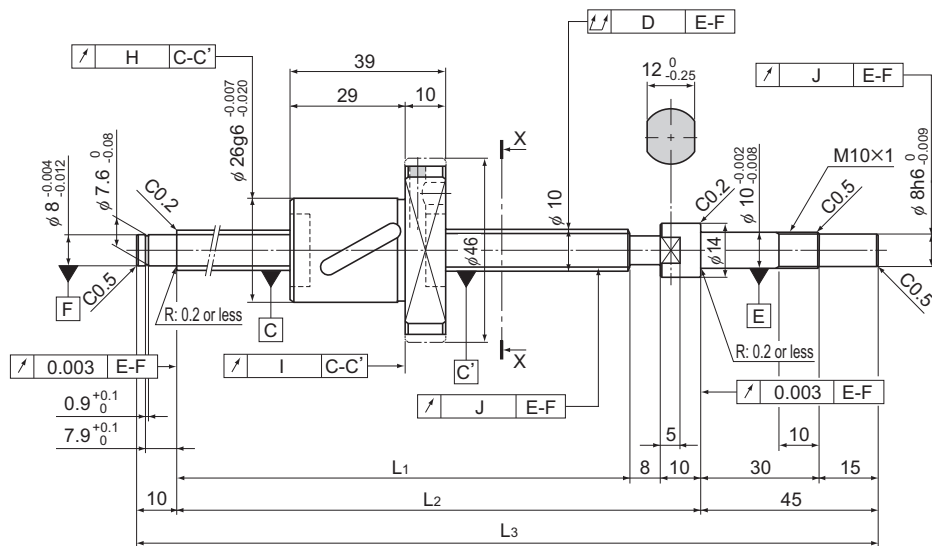

Model No.	Stroke	Screw shaft length		
		L ₁	L ₂	L ₃
BNK 1010-1.5RRG0+240LC5Y	100	167	185	240
BNK 1010-1.5RRG2+240LC7Y				
BNK 1010-1.5RRG0+290LC5Y	150	217	235	290
BNK 1010-1.5RRG2+290LC7Y				
BNK 1010-1.5RRG0+340LC5Y	200	267	285	340
BNK 1010-1.5RRG2+340LC7Y				
BNK 1010-1.5RRG0+390LC5Y	250	317	335	390
BNK 1010-1.5RRG2+390LC7Y				
BNK 1010-1.5RRG0+440LC5Y	300	367	385	440
BNK 1010-1.5RRG2+440LC7Y				

Note: For accuracy grade C5, GT clearance is also standardized.

Positioning Ball Screw

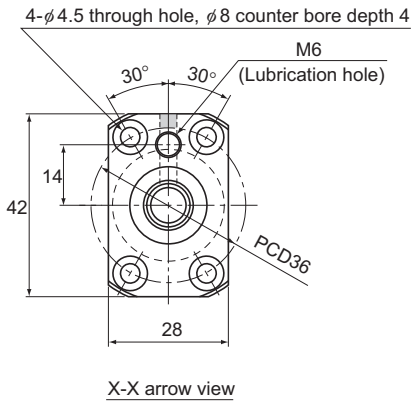

Ball screw specifications			
Lead (mm)	10		
BCD (mm)	10.5		
Thread minor diameter (mm)	7.8		
Threading direction, No. of threaded grooves	Rightward, 1		
No. of circuits	1.5 turns \times 1 row		
Clearance symbol	G0	GT	G2
Axial clearance (mm)	0	0.005 or less	0.02 or less
Basic dynamic load rating C_a (kN)	1.3	2.1	2.1
Basic static load rating C_{0a} (kN)	1.6	3.1	3.1
Preload torque (N·m)	9.8×10^3 to 4.9×10^2	—	—
Spacer ball	1 : 1	None	None
Rigidity value (N/ μ m)	70	140	
Circulation method	Return pipe		

Unit: mm

	Runout of the screw shaft axis D	Runout of the nut circumference H	Flange mounting surface runout I	Runout of the thread groove surface J	Lead angle accuracy		Nut mass kg	Shaft mass kg/m	Permissible rotational speed min ⁻¹
					Representative travel distance error	Fluctuation			
	0.04	0.012	0.01	0.011	± 0.02	0.018	0.17	0.5	5,000
	0.055	0.02	0.014	0.014	Travel distance: $\pm 0.05/300$		0.17	0.5	5,000
	0.04	0.012	0.01	0.011	± 0.023	0.018	0.17	0.5	5,000
	0.055	0.02	0.014	0.014	Travel distance: $\pm 0.05/300$		0.17	0.5	5,000
	0.05	0.012	0.01	0.011	± 0.023	0.018	0.17	0.5	5,000
	0.065	0.02	0.014	0.014	Travel distance: $\pm 0.05/300$		0.17	0.5	5,000
	0.05	0.012	0.01	0.011	± 0.025	0.02	0.17	0.5	5,000
	0.065	0.02	0.014	0.014	Travel distance: $\pm 0.05/300$		0.17	0.5	5,000
	0.065	0.012	0.01	0.011	± 0.025	0.02	0.17	0.5	5,000
	0.08	0.02	0.014	0.014	Travel distance: $\pm 0.05/300$		0.17	0.5	5,000

Positioning Ball Screw

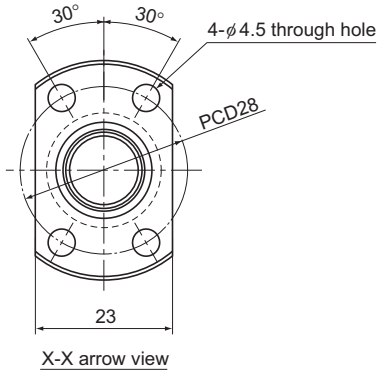

Ball screw specifications			
Lead (mm)	2		
BCD (mm)	12.3		
Thread minor diameter (mm)	11		
Threading direction, No. of threaded grooves	Rightward, 1		
No. of circuits	1 turn × 3 rows		
Clearance symbol	G0	GT	G2
Axial clearance (mm)	0	0.005 or less	0.02 or less
Basic dynamic load rating C_a (kN)	1.7	1.7	1.7
Basic static load rating C_{0a} (kN)	3.6	3.6	3.6
Preload torque (N·m)	4.0×10^3 to 3.4×10^2	—	—
Spacer ball	None	None	None
Rigidity value (N/μm)	120		
Circulation method	Deflector		

Unit: mm

	Runout of the screw shaft axis D	Runout of the nut circumference H	Flange mounting surface runout I	Runout of the thread groove surface J	Lead angle accuracy		Nut mass kg	Shaft mass kg/m	Permissible rotational speed min ⁻¹
					Representative travel distance error	Fluctuation			
	0.02	0.01	0.008	0.007	±0.008	0.008	0.05	0.71	3,500
	0.035	0.012	0.01	0.011	±0.018	0.018	0.05	0.71	3,500
	0.04	0.02	0.014	0.014	Travel distance: ±0.05/300		0.05	0.71	3,500
	0.03	0.01	0.008	0.007	±0.01	0.008	0.05	0.71	3,500
	0.04	0.012	0.01	0.011	±0.02	0.018	0.05	0.71	3,500
	0.055	0.02	0.014	0.014	Travel distance: ±0.05/300		0.05	0.71	3,500
	0.03	0.01	0.008	0.007	±0.01	0.008	0.05	0.71	3,500
	0.04	0.012	0.01	0.011	±0.02	0.018	0.05	0.71	3,500
	0.055	0.02	0.014	0.014	Travel distance: ±0.05/300		0.05	0.71	3,500
	0.04	0.01	0.008	0.007	±0.012	0.008	0.05	0.71	3,500
	0.05	0.012	0.01	0.011	±0.023	0.018	0.05	0.71	3,500
	0.055	0.02	0.014	0.014	Travel distance: ±0.05/300		0.05	0.71	3,500
	0.04	0.01	0.008	0.007	±0.012	0.008	0.05	0.71	3,500
	0.05	0.012	0.01	0.011	±0.023	0.018	0.05	0.71	3,500
	0.065	0.02	0.014	0.014	Travel distance: ±0.05/300		0.05	0.71	3,500

BNK1205-2.5 Shaft Diameter: 12; Lead: 5

DN value

70,000

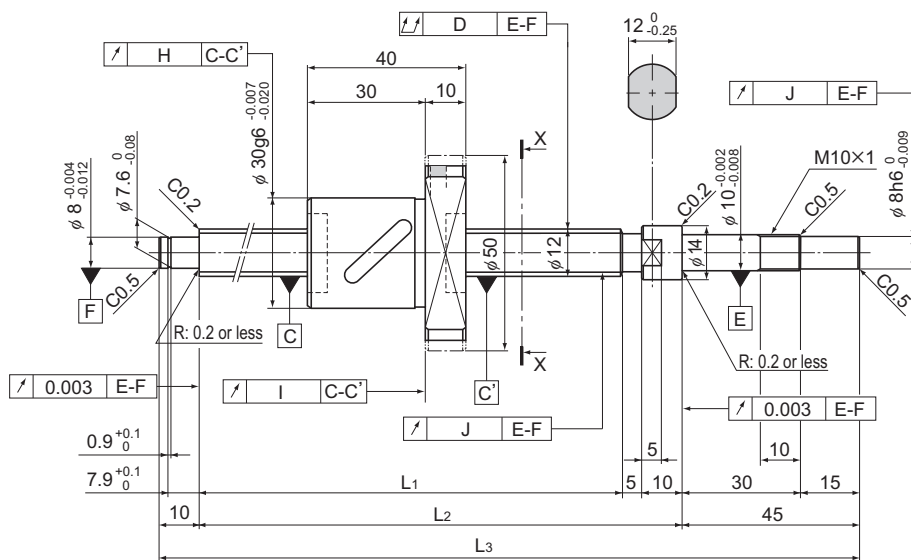

Model No.	Stroke	Screw shaft length		
		L ₁	L ₂	L ₃
BNK 1205-2.5RRG0+180LC3Y	50	110	125	180
BNK 1205-2.5RRG0+180LC5Y				
BNK 1205-2.5RRG2+180LC7Y				
BNK 1205-2.5RRG0+230LC3Y	100	160	175	230
BNK 1205-2.5RRG0+230LC5Y				
BNK 1205-2.5RRG2+230LC7Y				
BNK 1205-2.5RRG0+280LC3Y	150	210	225	280
BNK 1205-2.5RRG0+280LC5Y				
BNK 1205-2.5RRG2+280LC7Y				
BNK 1205-2.5RRG0+330LC3Y	200	260	275	330
BNK 1205-2.5RRG0+330LC5Y				
BNK 1205-2.5RRG2+330LC7Y				
BNK 1205-2.5RRG0+380LC3Y	250	310	325	380
BNK 1205-2.5RRG0+380LC5Y				
BNK 1205-2.5RRG2+380LC7Y				

Note: For accuracy grades C3 and C5, GT clearance is also available as standard.

Positioning Ball Screw

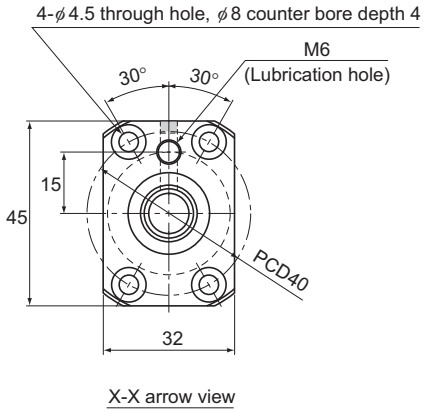

Ball screw specifications			
Lead (mm)	5		
BCD (mm)	12.3		
Thread minor diameter (mm)	9.6		
Threading direction, No. of threaded grooves	Rightward, 1		
No. of circuits	2.5 turns × 1 row		
Clearance symbol	G0	GT	G2
Axial clearance (mm)	0	0.005 or less	0.02 or less
Basic dynamic load rating C_a (kN)	2.3	3.7	3.7
Basic static load rating C_{0a} (kN)	3.2	6.4	6.4
Preload torque (N·m)	9.8×10^3 to 4.9×10^2	—	—
Spacer ball	1 : 1	None	None
Rigidity value (N/μm)	60	120	
Circulation method	Return pipe		

Unit: mm

	Runout of the screw shaft axis D	Runout of the nut circumference H	Flange mounting surface runout I	Runout of the thread groove surface J	Lead angle accuracy		Nut mass kg	Shaft mass kg/m	Permissible rotational speed min ⁻¹
					Representative travel distance error	Fluctuation			
	0.02	0.009	0.008	0.008	±0.01	0.008	0.22	0.61	5,000
	0.035	0.012	0.01	0.011	±0.02	0.018	0.22	0.61	5,000
	0.04	0.02	0.014	0.014	Travel distance: ±0.05/300		0.22	0.61	5,000
	0.03	0.009	0.008	0.008	±0.01	0.008	0.22	0.61	5,000
	0.04	0.012	0.01	0.011	±0.02	0.018	0.22	0.61	5,000
	0.055	0.02	0.014	0.014	Travel distance: ±0.05/300		0.22	0.61	5,000
	0.03	0.009	0.008	0.008	±0.012	0.008	0.22	0.61	5,000
	0.04	0.012	0.01	0.011	±0.023	0.018	0.22	0.61	5,000
	0.055	0.02	0.014	0.014	Travel distance: ±0.05/300		0.22	0.61	5,000
	0.04	0.009	0.008	0.008	±0.012	0.008	0.22	0.61	5,000
	0.05	0.012	0.01	0.011	±0.023	0.018	0.22	0.61	5,000
	0.065	0.02	0.014	0.014	Travel distance: ±0.05/300		0.22	0.61	5,000
	0.04	0.009	0.008	0.008	±0.012	0.008	0.22	0.61	5,000
	0.05	0.012	0.01	0.011	±0.023	0.018	0.22	0.61	5,000
	0.065	0.02	0.014	0.014	Travel distance: ±0.05/300		0.22	0.61	5,000

Ball Screw

Positioning Ball Screw

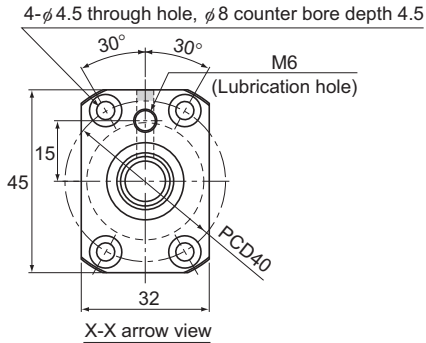

Ball screw specifications	
Lead (mm)	8
BCD (mm)	12.65
Thread minor diameter (mm)	9.7
Threading direction, No. of threaded grooves	Rightward, 1
No. of circuits	2.6 turns \times 1 row
Clearance symbol	G2
Axial clearance (mm)	0.02 or less
Basic dynamic load rating C_a (kN)	4.7
Basic static load rating C_{0a} (kN)	7.5
Preload torque (N·m)	—
Spacer ball	None
Rigidity value (N/ μ m)	127
Circulation method	Return pipe

Unit: mm

	Runout of the screw shaft axis	Runout of the nut circumference	Flange mounting surface runout	Runout of the thread groove surface	Lead angle accuracy	Nut mass	Shaft mass	Permissible rotational speed
	D	H	I	J		kg	kg/m	
	0.04	0.02	0.014	0.014	Travel distance: $\pm 0.05/300$	0.27	0.64	3,500
	0.055	0.02	0.014	0.014	Travel distance: $\pm 0.05/300$	0.27	0.64	3,500
	0.055	0.02	0.014	0.014	Travel distance: $\pm 0.05/300$	0.27	0.64	3,500
	0.065	0.02	0.014	0.014	Travel distance: $\pm 0.05/300$	0.27	0.64	3,500
	0.065	0.02	0.014	0.014	Travel distance: $\pm 0.05/300$	0.27	0.64	3,500

Positioning Ball Screw

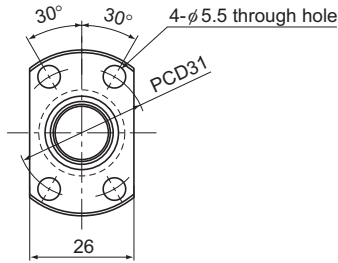

X-X arrow view

Ball screw specifications			
Lead (mm)	2		
BCD (mm)	14.3		
Thread minor diameter (mm)	13		
Threading direction, No. of threaded grooves	Rightward, 1		
No. of circuits	1 turn × 3 rows		
Clearance symbol	G0	GT	G2
Axial clearance (mm)	0	0.005 or less	0.02 or less
Basic dynamic load rating C_a (kN)	1.8	1.8	1.8
Basic static load rating C_{0a} (kN)	4.3	4.3	4.3
Preload torque (N·m)	4.9×10^3 to 4.9×10^2	—	—
Spacer ball	None	None	None
Rigidity value (N/μm)	140		
Circulation method	Deflector		

Unit: mm

	Runout of the screw shaft axis D	Runout of the nut circumference H	Flange mounting surface runout I	Runout of the thread groove surface J	Lead angle accuracy		Nut mass kg	Shaft mass kg/m	Permissible rotational speed min ⁻¹
					Representative travel distance error	Fluctuation			
	0.02	0.01	0.008	0.009	±0.008	0.008	0.15	1	3,500
	0.025	0.012	0.01	0.012	±0.018	0.018	0.15	1	3,500
	0.04	0.02	0.014	0.014	Travel distance: ±0.05/300		0.15	1	3,500
	0.025	0.01	0.008	0.009	±0.01	0.008	0.15	1	3,500
	0.03	0.012	0.01	0.012	±0.02	0.018	0.15	1	3,500
	0.045	0.02	0.014	0.014	Travel distance: ±0.05/300		0.15	1	3,500
	0.025	0.01	0.008	0.009	±0.01	0.008	0.15	1	3,500
	0.03	0.012	0.01	0.012	±0.02	0.018	0.15	1	3,500
	0.045	0.02	0.014	0.014	Travel distance: ±0.05/300		0.15	1	3,500
	0.03	0.01	0.008	0.009	±0.012	0.008	0.15	1	3,500
	0.04	0.012	0.01	0.012	±0.023	0.018	0.15	1	3,500
	0.055	0.02	0.014	0.014	Travel distance: ±0.05/300		0.15	1	3,500
	0.04	0.01	0.008	0.009	±0.013	0.01	0.15	1	3,500
	0.05	0.012	0.01	0.012	±0.025	0.02	0.15	1	3,500
	0.06	0.02	0.014	0.014	Travel distance: ±0.05/300		0.15	1	3,500

BNK1404-3 Shaft Diameter: 14; Lead: 4

DN value

70,000

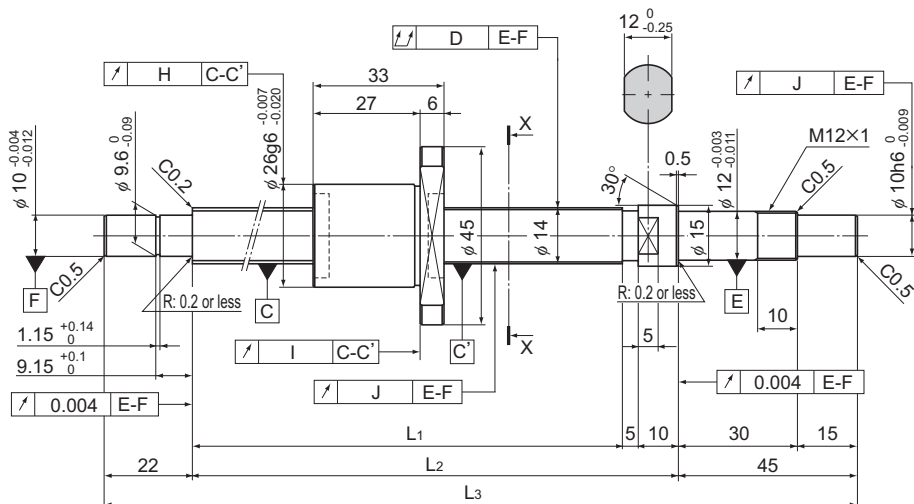

Model No.	Stroke	Screw shaft length		
		L ₁	L ₂	L ₃
BNK 1404-3RRG0+230LC3Y	100	148	163	230
BNK 1404-3RRG0+230LC5Y				
BNK 1404-3RRG2+230LC7Y				
BNK 1404-3RRG0+280LC3Y	150	198	213	280
BNK 1404-3RRG0+280LC5Y				
BNK 1404-3RRG2+280LC7Y				
BNK 1404-3RRG0+330LC3Y	200	248	263	330
BNK 1404-3RRG0+330LC5Y				
BNK 1404-3RRG2+330LC7Y				
BNK 1404-3RRG0+430LC3Y	300	348	363	430
BNK 1404-3RRG0+430LC5Y				
BNK 1404-3RRG2+430LC7Y				
BNK 1404-3RRG0+530LC3Y	400	448	463	530
BNK 1404-3RRG0+530LC5Y				
BNK 1404-3RRG2+530LC7Y				

Notes: A stainless steel type is also available for Model BNK1404. When placing an order, add symbol "M" to the end of the model number.

(Example) BNK1404-3RRG0+230LC3Y M

Symbol for stainless steel type

For accuracy grades C3 and C5, GT clearance is also available as standard.

Positioning Ball Screw

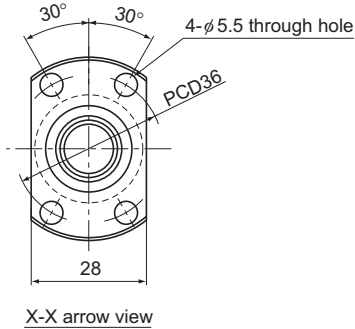

Ball screw specifications			
Lead (mm)	4		
BCD (mm)	14.65		
Thread minor diameter (mm)	12.2		
Threading direction, No. of threaded grooves	Rightward, 1		
No. of circuits	1 turn × 3 rows		
Clearance symbol	G0	GT	G2
Axial clearance (mm)	0	0.005 or less	0.02 or less
Basic dynamic load rating C_a (kN)	4.2	4.2	4.2
Basic static load rating C_{0a} (kN)	7.6	7.6	7.6
Preload torque (N·m)	9.8×10^3 to 6.9×10^2	—	—
Spacer ball	None	None	None
Rigidity value (N/μm)	190		
Circulation method	Deflector		

Unit: mm

	Runout of the screw shaft axis D	Runout of the nut circumference H	Flange mounting surface runout I	Runout of the thread groove surface J	Lead angle accuracy		Nut mass kg	Shaft mass kg/m	Permissible rotational speed min ⁻¹
					Representative travel distance error	Fluctuation			
	0.025	0.01	0.008	0.009	±0.01	0.008	0.13	0.8	3,500
	0.03	0.012	0.01	0.012	±0.02	0.018	0.13	0.8	3,500
	0.045	0.02	0.014	0.014	Travel distance: ±0.05/300		0.13	0.8	3,500
	0.025	0.01	0.008	0.009	±0.01	0.008	0.13	0.8	3,500
	0.03	0.012	0.01	0.012	±0.02	0.018	0.13	0.8	3,500
	0.045	0.02	0.014	0.014	Travel distance: ±0.05/300		0.13	0.8	3,500
	0.03	0.01	0.008	0.009	±0.012	0.008	0.13	0.8	3,500
	0.04	0.012	0.01	0.012	±0.023	0.018	0.13	0.8	3,500
	0.055	0.02	0.014	0.014	Travel distance: ±0.05/300		0.13	0.8	3,500
	0.04	0.01	0.008	0.009	±0.013	0.01	0.13	0.8	3,500
	0.05	0.012	0.01	0.012	±0.025	0.02	0.13	0.8	3,500
	0.06	0.02	0.014	0.014	Travel distance: ±0.05/300		0.13	0.8	3,500
	0.045	0.01	0.008	0.009	±0.015	0.01	0.13	0.8	3,500
	0.055	0.012	0.01	0.012	±0.027	0.02	0.13	0.8	3,500
	0.075	0.02	0.014	0.014	Travel distance: ±0.05/300		0.13	0.8	3,500

Ball Screw

Positioning Ball Screw

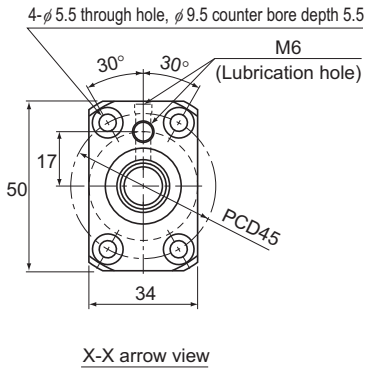

Ball screw specifications			
Lead (mm)	8		
BCD (mm)	14.75		
Thread minor diameter (mm)	11.2		
Threading direction, No. of threaded grooves	Rightward, 1		
No. of circuits	2.5 turns \times 1 row		
Clearance symbol	G0	GT	G2
Axial clearance (mm)	0	0.005 or less	0.02 or less
Basic dynamic load rating C_a (kN)	4.3	6.9	6.9
Basic static load rating C_{0a} (kN)	5.8	11.5	11.5
Preload torque (N-m)	2×10^2 to 7.8×10^2	—	—
Spacer ball	1 : 1	None	None
Rigidity value (N/ μ m)	80	150	
Circulation method	Return pipe		

Unit: mm

	Runout of the screw shaft axis D	Runout of the nut circumference H	Flange mounting surface runout I	Runout of the thread groove surface J	Lead angle accuracy		Nut mass kg	Shaft mass kg/m	Permissible rotational speed min ⁻¹
					Representative travel distance error	Fluctuation			
	0.035	0.015	0.011	0.012	± 0.023	0.018	0.29	0.84	4,740
	0.055	0.03	0.018	0.014	Travel distance: $\pm 0.05/300$		0.29	0.84	4,740
	0.035	0.015	0.011	0.012	± 0.023	0.018	0.29	0.84	4,740
	0.055	0.03	0.018	0.014	Travel distance: $\pm 0.05/300$		0.29	0.84	4,740
	0.04	0.015	0.011	0.012	± 0.025	0.02	0.29	0.84	4,740
	0.06	0.03	0.018	0.014	Travel distance: $\pm 0.05/300$		0.29	0.84	4,740
	0.04	0.015	0.011	0.012	± 0.025	0.02	0.29	0.84	4,740
	0.06	0.03	0.018	0.014	Travel distance: $\pm 0.05/300$		0.29	0.84	4,740
	0.05	0.015	0.011	0.012	± 0.027	0.02	0.29	0.84	4,740
	0.075	0.03	0.018	0.014	Travel distance: $\pm 0.05/300$		0.29	0.84	4,740
	0.05	0.015	0.011	0.012	± 0.027	0.02	0.29	0.84	4,740
	0.075	0.03	0.018	0.014	Travel distance: $\pm 0.05/300$		0.29	0.84	4,740
	0.05	0.015	0.011	0.012	± 0.03	0.023	0.29	0.84	4,740
	0.075	0.03	0.018	0.014	Travel distance: $\pm 0.05/300$		0.29	0.84	4,740
	0.065	0.015	0.011	0.012	± 0.03	0.023	0.29	0.84	4,740
	0.09	0.03	0.018	0.014	Travel distance: $\pm 0.05/300$		0.29	0.84	4,740
	0.065	0.015	0.011	0.012	± 0.035	0.025	0.29	0.84	4,740
	0.09	0.03	0.018	0.014	Travel distance: $\pm 0.05/300$		0.29	0.84	4,740
	0.065	0.015	0.011	0.012	± 0.035	0.025	0.29	0.84	4,740
	0.09	0.03	0.018	0.014	Travel distance: $\pm 0.05/300$		0.29	0.84	4,740
	0.085	0.015	0.011	0.012	± 0.035	0.025	0.29	0.84	4,740
	0.12	0.03	0.018	0.014	Travel distance: $\pm 0.05/300$		0.29	0.84	4,740

Ball Screw

Positioning Ball Screw

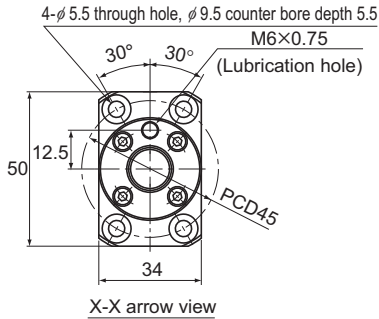

Ball screw specifications			
Lead (mm)	10		
BCD (mm)	15.75		
Thread minor diameter (mm)	12.5		
Threading direction, No. of threaded grooves	Rightward, 2		
No. of circuits	2.8 turns × 2 rows		
Clearance symbol	G0	GT	G2
Axial clearance (mm)	0	0.005 or less	0.02 or less
Basic dynamic load rating C_a (kN)	9	14.3	14.3
Basic static load rating C_{0a} (kN)	13.9	27.9	27.9
Preload torque (N-m)	2×10^2 to 9.8×10^2	—	—
Spacer ball	1 : 1	None	None
Rigidity value (N/μm)	190	350	
Circulation method	End cap		

Unit: mm

	Runout of the screw shaft axis D	Runout of the nut circumference H	Flange mounting surface runout I	Runout of the thread groove surface J	Lead angle accuracy		Nut mass kg	Shaft mass kg/m	Permissible rotational speed min ⁻¹
					Representative travel distance error	Fluctuation			
	0.035	0.015	0.011	0.012	±0.023	0.018	0.22	0.76	4,440
	0.055	0.03	0.018	0.014	Travel distance: ±0.05/300		0.22	0.76	4,440
	0.035	0.015	0.011	0.012	±0.023	0.018	0.22	0.76	4,440
	0.055	0.03	0.018	0.014	Travel distance: ±0.05/300		0.22	0.76	4,440
	0.04	0.015	0.011	0.012	±0.025	0.02	0.22	0.76	4,440
	0.06	0.03	0.018	0.014	Travel distance: ±0.05/300		0.22	0.76	4,440
	0.04	0.015	0.011	0.012	±0.025	0.02	0.22	0.76	4,440
	0.06	0.03	0.018	0.014	Travel distance: ±0.05/300		0.22	0.76	4,440
	0.05	0.015	0.011	0.012	±0.027	0.02	0.22	0.76	4,440
	0.075	0.03	0.018	0.014	Travel distance: ±0.05/300		0.22	0.76	4,440
	0.05	0.015	0.011	0.012	±0.027	0.02	0.22	0.76	4,440
	0.075	0.03	0.018	0.014	Travel distance: ±0.05/300		0.22	0.76	4,440
	0.05	0.015	0.011	0.012	±0.03	0.023	0.22	0.76	4,440
	0.075	0.03	0.018	0.014	Travel distance: ±0.05/300		0.22	0.76	4,440
	0.065	0.015	0.011	0.012	±0.03	0.023	0.22	0.76	4,440
	0.09	0.03	0.018	0.014	Travel distance: ±0.05/300		0.22	0.76	4,440
	0.065	0.015	0.011	0.012	±0.035	0.025	0.22	0.76	4,440
	0.09	0.03	0.018	0.014	Travel distance: ±0.05/300		0.22	0.76	4,440
	0.065	0.015	0.011	0.012	±0.035	0.025	0.22	0.76	4,440
	0.09	0.03	0.018	0.014	Travel distance: ±0.05/300		0.22	0.76	4,440
	0.085	0.015	0.011	0.012	±0.035	0.025	0.22	0.76	4,440
	0.12	0.03	0.018	0.014	Travel distance: ±0.05/300		0.22	0.76	4,440
	0.085	0.015	0.011	0.012	±0.04	0.027	0.22	0.76	4,440
	0.12	0.03	0.018	0.014	Travel distance: ±0.05/300		0.22	0.76	4,440

Ball Screw

Positioning Ball Screw

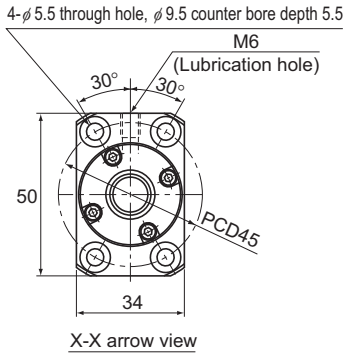

Ball screw specifications			
Lead (mm)	20		
BCD (mm)	15.75		
Thread minor diameter (mm)	12.5		
Threading direction, No. of threaded grooves	Rightward, 2		
No. of circuits	1.5 turns × 2 rows		
Clearance symbol	G0	GT	G2
Axial clearance (mm)	0	0.005 or less	0.02 or less
Basic dynamic load rating C_a (kN)	5.1	8	8
Basic static load rating C_{0a} (kN)	7.9	15.8	15.8
Preload torque (N-m)	2×10^2 to 8.8×10^2	—	—
Spacer ball	1 : 1	None	None
Rigidity value (N/μm)	110	200	
Circulation method	End cap		

Unit: mm

	Runout of the screw shaft axis D	Runout of the nut circumference H	Flange mounting surface runout I	Runout of the thread groove surface J	Lead angle accuracy		Nut mass kg	Shaft mass kg/m	Permissible rotational speed min ⁻¹
					Representative travel distance error	Fluctuation			
	0.035	0.015	0.011	0.012	±0.023	0.018	0.32	1.05	4,440
	0.055	0.03	0.018	0.014	Travel distance: ±0.05/300		0.32	1.05	4,440
	0.035	0.015	0.011	0.012	±0.023	0.018	0.32	1.05	4,440
	0.055	0.03	0.018	0.014	Travel distance: ±0.05/300		0.32	1.05	4,440
	0.04	0.015	0.011	0.012	±0.025	0.02	0.32	1.05	4,440
	0.06	0.03	0.018	0.014	Travel distance: ±0.05/300		0.32	1.05	4,440
	0.04	0.015	0.011	0.012	±0.025	0.02	0.32	1.05	4,440
	0.06	0.03	0.018	0.014	Travel distance: ±0.05/300		0.32	1.05	4,440
	0.05	0.015	0.011	0.012	±0.027	0.02	0.32	1.05	4,440
	0.075	0.03	0.018	0.014	Travel distance: ±0.05/300		0.32	1.05	4,440
	0.05	0.015	0.011	0.012	±0.027	0.02	0.32	1.05	4,440
	0.075	0.03	0.018	0.014	Travel distance: ±0.05/300		0.32	1.05	4,440
	0.05	0.015	0.011	0.012	±0.03	0.023	0.32	1.05	4,440
	0.075	0.03	0.018	0.014	Travel distance: ±0.05/300		0.32	1.05	4,440
	0.065	0.015	0.011	0.012	±0.03	0.023	0.32	1.05	4,440
	0.09	0.03	0.018	0.014	Travel distance: ±0.05/300		0.32	1.05	4,440
	0.065	0.015	0.011	0.012	±0.035	0.025	0.32	1.05	4,440
	0.09	0.03	0.018	0.014	Travel distance: ±0.05/300		0.32	1.05	4,440
	0.065	0.015	0.011	0.012	±0.035	0.025	0.32	1.05	4,440
	0.09	0.03	0.018	0.014	Travel distance: ±0.05/300		0.32	1.05	4,440
	0.085	0.015	0.011	0.012	±0.035	0.025	0.32	1.05	4,440
	0.12	0.03	0.018	0.014	Travel distance: ±0.05/300		0.32	1.05	4,440
	0.085	0.015	0.011	0.012	±0.04	0.027	0.32	1.05	4,440
	0.12	0.03	0.018	0.014	Travel distance: ±0.05/300		0.32	1.05	4,440

Ball Screw

BNK1616-3.6 Shaft Diameter: 16; Lead: 16

DN value

70,000

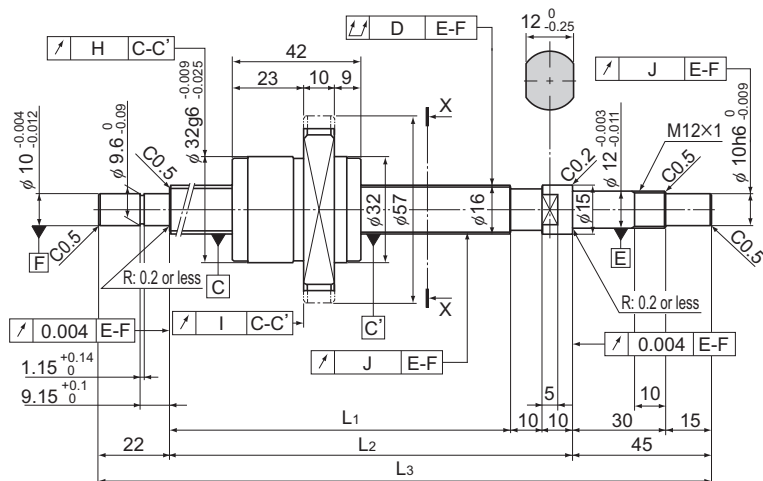

Model No.	Stroke	Screw shaft length		
		L ₁	L ₂	L ₃
BNK 1616-3.6G0+321LC5Y	150	234	254	321
BNK 1616-3.6G2+321LC7Y				
BNK 1616-3.6G0+371LC5Y	200	284	304	371
BNK 1616-3.6G2+371LC7Y				
BNK 1616-3.6G0+421LC5Y	250	334	354	421
BNK 1616-3.6G2+421LC7Y				
BNK 1616-3.6G0+471LC5Y	300	384	404	471
BNK 1616-3.6G2+471LC7Y				
BNK 1616-3.6G0+521LC5Y	350	434	454	521
BNK 1616-3.6G2+521LC7Y				
BNK 1616-3.6G0+571LC5Y	400	484	504	571
BNK 1616-3.6G2+571LC7Y				
BNK 1616-3.6G0+621LC5Y	450	534	554	621
BNK 1616-3.6G2+621LC7Y				
BNK 1616-3.6G0+671LC5Y	500	584	604	671
BNK 1616-3.6G2+671LC7Y				
BNK 1616-3.6G0+721LC5Y	550	634	654	721
BNK 1616-3.6G2+721LC7Y				
BNK 1616-3.6G0+771LC5Y	600	684	704	771
BNK 1616-3.6G2+771LC7Y				
BNK 1616-3.6G0+871LC5Y	700	784	804	871
BNK 1616-3.6G2+871LC7Y				
BNK 1616-3.6G0+971LC5Y	800	884	904	971
BNK 1616-3.6G2+971LC7Y				

Note: For accuracy grade C5, GT clearance is also standardized.

Positioning Ball Screw

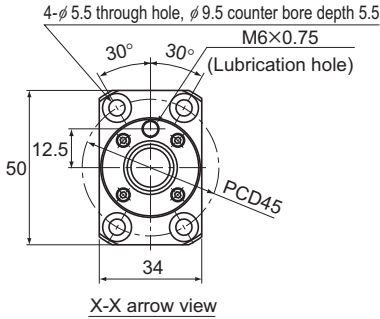

Ball screw specifications			
Lead (mm)	16		
BCD (mm)	16.65		
Thread minor diameter (mm)	13.7		
Threading direction, No. of threaded grooves	Rightward, 2		
No. of circuits	1.8 turns \times 2 rows		
Clearance symbol	G0	GT	G2
Axial clearance (mm)	0	0.005 or less	0.02 or less
Basic dynamic load rating C_a (kN)	4.4	7.1	7.1
Basic static load rating C_{0a} (kN)	7.2	14.3	14.3
Preload torque (N-m)	2×10^2 to 9.8×10^2	—	—
Spacer ball	1 : 1	None	None
Rigidity value (N/ μ m)	120	230	
Circulation method	End cap		

Unit: mm

	Runout of the screw shaft axis D	Runout of the nut circumference H	Flange mounting surface runout I	Runout of the thread groove surface J	Lead angle accuracy		Nut mass kg	Shaft mass kg/m	Permissible rotational speed min ⁻¹
					Representative travel distance error	Fluctuation			
	0.035	0.015	0.011	0.012	± 0.023	0.018	0.2	1.25	4,200
	0.055	0.03	0.018	0.014	Travel distance: $\pm 0.05/300$		0.2	1.25	4,200
	0.035	0.015	0.011	0.012	± 0.023	0.018	0.2	1.25	4,200
	0.055	0.03	0.018	0.014	Travel distance: $\pm 0.05/300$		0.2	1.25	4,200
	0.04	0.015	0.011	0.012	± 0.025	0.02	0.2	1.25	4,200
	0.06	0.03	0.018	0.014	Travel distance: $\pm 0.05/300$		0.2	1.25	4,200
	0.04	0.015	0.011	0.012	± 0.025	0.02	0.2	1.25	4,200
	0.06	0.03	0.018	0.014	Travel distance: $\pm 0.05/300$		0.2	1.25	4,200
	0.05	0.015	0.011	0.012	± 0.027	0.02	0.2	1.25	4,200
	0.075	0.03	0.018	0.014	Travel distance: $\pm 0.05/300$		0.2	1.25	4,200
	0.05	0.015	0.011	0.012	± 0.027	0.02	0.2	1.25	4,200
	0.075	0.03	0.018	0.014	Travel distance: $\pm 0.05/300$		0.2	1.25	4,200
	0.05	0.015	0.011	0.012	± 0.03	0.023	0.2	1.25	4,200
	0.075	0.03	0.018	0.014	Travel distance: $\pm 0.05/300$		0.2	1.25	4,200
	0.065	0.015	0.011	0.012	± 0.03	0.023	0.2	1.25	4,200
	0.09	0.03	0.018	0.014	Travel distance: $\pm 0.05/300$		0.2	1.25	4,200
	0.065	0.015	0.011	0.012	± 0.035	0.025	0.2	1.25	4,200
	0.09	0.03	0.018	0.014	Travel distance: $\pm 0.05/300$		0.2	1.25	4,200
	0.085	0.015	0.011	0.012	± 0.035	0.025	0.2	1.25	4,200
	0.12	0.03	0.018	0.014	Travel distance: $\pm 0.05/300$		0.2	1.25	4,200
	0.085	0.015	0.011	0.012	± 0.04	0.027	0.2	1.25	4,200
	0.12	0.03	0.018	0.014	Travel distance: $\pm 0.05/300$		0.2	1.25	4,200

Ball Screw

BNK2010-2.5 Shaft Diameter: 20; Lead: 10

DN value

70,000

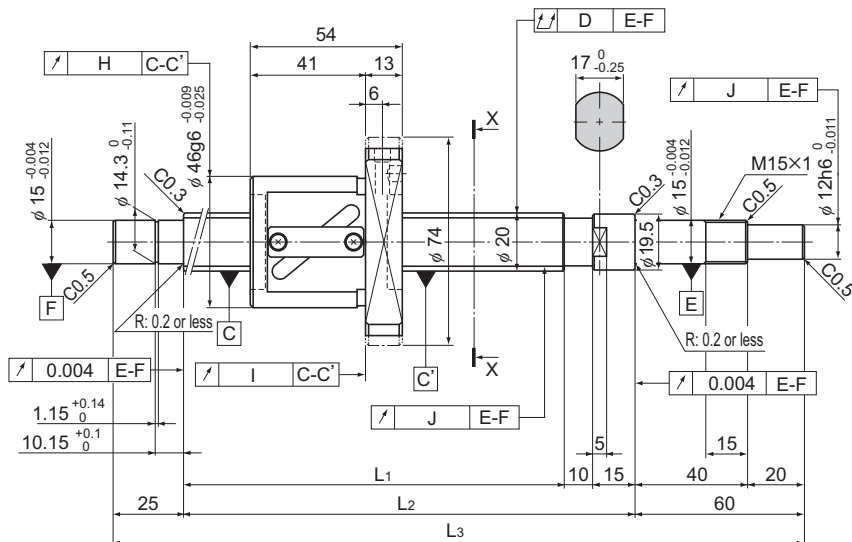

Model No.	Stroke	Screw shaft length		
		L ₁	L ₂	L ₃
BNK 2010-2.5RRG0+499LC5Y	300	389	414	499
BNK 2010-2.5RRG2+499LC7Y				
BNK 2010-2.5RRG0+599LC5Y	400	489	514	599
BNK 2010-2.5RRG2+599LC7Y				
BNK 2010-2.5RRG0+699LC5Y	500	589	614	699
BNK 2010-2.5RRG2+699LC7Y				
BNK 2010-2.5RRG0+799LC5Y	600	689	714	799
BNK 2010-2.5RRG2+799LC7Y				
BNK 2010-2.5RRG0+899LC5Y	700	789	814	899
BNK 2010-2.5RRG2+899LC7Y				
BNK 2010-2.5RRG0+999LC5Y	800	889	914	999
BNK 2010-2.5RRG2+999LC7Y				
BNK 2010-2.5RRG0+1099LC5Y	900	989	1,014	1,099
BNK 2010-2.5RRG2+1099LC7Y				
BNK 2010-2.5RRG0+1199LC5Y	1,000	1,089	1,114	1,199
BNK 2010-2.5RRG2+1199LC7Y				
BNK 2010-2.5RRG0+1299LC5Y	1,100	1,189	1,214	1,299
BNK 2010-2.5RRG2+1299LC7Y				

Notes: For accuracy grade C5, GT clearance is also standardized.
Plug the unused lubrication hole before using the product.

Positioning Ball Screw

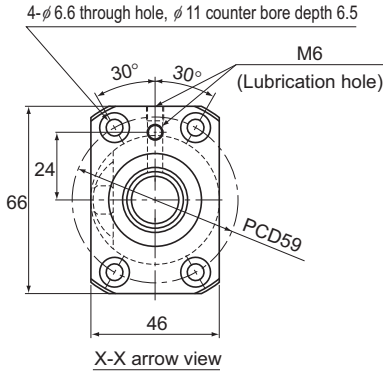

Ball screw specifications			
Lead (mm)	10		
BCD (mm)	21		
Thread minor diameter (mm)	16.4		
Threading direction, No. of threaded grooves	Rightward, 1		
No. of circuits	2.5 turns \times 1 row		
Clearance symbol	G0	GT	G2
Axial clearance (mm)	0	0.005 or less	0.02 or less
Basic dynamic load rating C_a (kN)	7	11.1	11.1
Basic static load rating C_{0a} (kN)	11	22	22
Preload torque (N-m)	2×10^2 to 9.8×10^2	—	—
Spacer ball	1 : 1	None	None
Rigidity value (N/ μ m)	110	210	
Circulation method	Return pipe		

Unit: mm

	Runout of the screw shaft axis D	Runout of the nut circumference H	Flange mounting surface runout I	Runout of the thread groove surface J	Lead angle accuracy		Nut mass kg	Shaft mass kg/m	Permissible rotational speed min ⁻¹
					Representative travel distance error	Fluctuation			
	0.04	0.015	0.011	0.012	± 0.025	0.02	0.58	1.81	3,330
	0.06	0.03	0.018	0.014	Travel distance: $\pm 0.05/300$		0.58	1.81	3,330
	0.05	0.015	0.011	0.012	± 0.027	0.02	0.58	1.81	3,330
	0.075	0.03	0.018	0.014	Travel distance: $\pm 0.05/300$		0.58	1.81	3,330
	0.065	0.015	0.011	0.012	± 0.03	0.023	0.58	1.81	3,330
	0.09	0.03	0.018	0.014	Travel distance: $\pm 0.05/300$		0.58	1.81	3,330
	0.065	0.015	0.011	0.012	± 0.035	0.025	0.58	1.81	3,330
	0.09	0.03	0.018	0.014	Travel distance: $\pm 0.05/300$		0.58	1.81	3,330
	0.085	0.015	0.011	0.012	± 0.035	0.025	0.58	1.81	3,330
	0.12	0.03	0.018	0.014	Travel distance: $\pm 0.05/300$		0.58	1.81	3,330
	0.085	0.015	0.011	0.012	± 0.04	0.027	0.58	1.81	3,330
	0.12	0.03	0.018	0.014	Travel distance: $\pm 0.05/300$		0.58	1.81	3,330
	0.11	0.015	0.011	0.012	± 0.04	0.027	0.58	1.81	3,330
	0.15	0.03	0.018	0.014	Travel distance: $\pm 0.05/300$		0.58	1.81	3,330
	0.11	0.015	0.011	0.012	± 0.046	0.03	0.58	1.81	3,330
	0.15	0.03	0.018	0.014	Travel distance: $\pm 0.05/300$		0.58	1.81	3,330
	0.15	0.015	0.011	0.012	± 0.046	0.03	0.58	1.81	3,330
	0.19	0.03	0.018	0.014	Travel distance: $\pm 0.05/300$		0.58	1.81	3,330

Ball Screw

Positioning Ball Screw

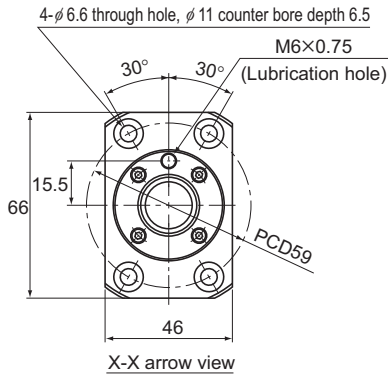

Ball screw specifications			
Lead (mm)	20		
BCD (mm)	20.75		
Thread minor diameter (mm)	17.5		
Threading direction, No. of threaded grooves	Rightward, 2		
No. of circuits	1.8 turns × 2 rows		
Clearance symbol	G0	GT	G2
Axial clearance (mm)	0	0.005 or less	0.02 or less
Basic dynamic load rating C_a (kN)	7	11.1	11.1
Basic static load rating C_{0a} (kN)	12.3	24.7	24.7
Preload torque (N-m)	2×10^2 to 9.8×10^2	—	—
Spacer ball	1 : 1	None	None
Rigidity value (N/μm)	160	290	
Circulation method	End cap		

Unit: mm

	Runout of the screw shaft axis D	Runout of the nut circumference H	Flange mounting surface runout I	Runout of the thread groove surface J	Lead angle accuracy		Nut mass kg	Shaft mass kg/m	Permissible rotational speed min ⁻¹
					Representative travel distance error	Fluctuation			
	0.05	0.015	0.011	0.012	±0.027	0.02	0.39	2.04	3,370
	0.075	0.03	0.018	0.014	Travel distance: ±0.05/300		0.39	2.04	3,370
	0.05	0.015	0.011	0.012	±0.03	0.023	0.39	2.04	3,370
	0.075	0.03	0.018	0.014	Travel distance: ±0.05/300		0.39	2.04	3,370
	0.065	0.015	0.011	0.012	±0.03	0.023	0.39	2.04	3,370
	0.09	0.03	0.018	0.014	Travel distance: ±0.05/300		0.39	2.04	3,370
	0.085	0.015	0.011	0.012	±0.035	0.025	0.39	2.04	3,370
	0.12	0.03	0.018	0.014	Travel distance: ±0.05/300		0.39	2.04	3,370
	0.085	0.015	0.011	0.012	±0.04	0.027	0.39	2.04	3,370
	0.12	0.03	0.018	0.014	Travel distance: ±0.05/300		0.39	2.04	3,370
	0.11	0.015	0.011	0.012	±0.04	0.027	0.39	2.04	3,370
	0.15	0.03	0.018	0.014	Travel distance: ±0.05/300		0.39	2.04	3,370
	0.11	0.015	0.011	0.012	±0.046	0.03	0.39	2.04	3,370
	0.15	0.03	0.018	0.014	Travel distance: ±0.05/300		0.39	2.04	3,370
	0.11	0.015	0.011	0.012	±0.046	0.03	0.39	2.04	3,370
	0.15	0.03	0.018	0.014	Travel distance: ±0.05/300		0.39	2.04	3,370
	0.15	0.015	0.011	0.012	±0.046	0.03	0.39	2.04	3,370
	0.19	0.03	0.018	0.014	Travel distance: ±0.05/300		0.39	2.04	3,370

Ball Screw

BNK2520-3.6 Shaft Diameter: 25; Lead: 20

DN value	70,000
----------	--------

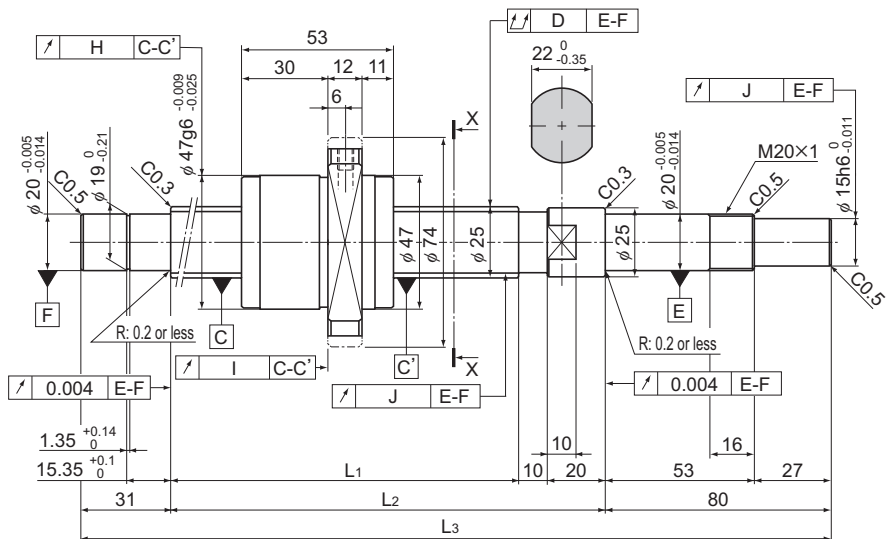

Model No.	Stroke	Screw shaft length		
		L ₁	L ₂	L ₃
BNK 2520-3.6G0+751LC5Y	500	610	640	751
BNK 2520-3.6G2+751LC7Y				
BNK 2520-3.6G0+851LC5Y	600	710	740	851
BNK 2520-3.6G2+851LC7Y				
BNK 2520-3.6G0+1051LC5Y	800	910	940	1,051
BNK 2520-3.6G2+1051LC7Y				
BNK 2520-3.6G0+1251LC5Y	1,000	1,110	1,140	1,251
BNK 2520-3.6G2+1251LC7Y				
BNK 2520-3.6G0+1451LC5Y	1,200	1,310	1,340	1,451
BNK 2520-3.6G2+1451LC7Y				
BNK 2520-3.6G0+1651LC5Y	1,400	1,510	1,540	1,651
BNK 2520-3.6G2+1651LC7Y				
BNK 2520-3.6G0+1851LC5Y	1,600	1,710	1,740	1,851
BNK 2520-3.6G2+1851LC7Y				

Note: For accuracy grade C5, GT clearance is also standardized.

Positioning Ball Screw

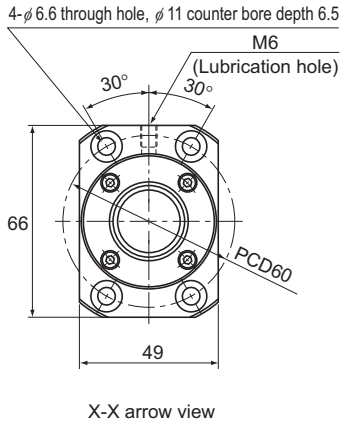

Ball screw specifications			
Lead (mm)	20		
BCD (mm)	26		
Thread minor diameter (mm)	21.9		
Threading direction, No. of threaded grooves	Rightward, 2		
No. of circuits	1.8 turns \times 2 rows		
Clearance symbol	G0	GT	G2
Axial clearance (mm)	0	0.005 or less	0.02 or less
Basic dynamic load rating C_a (kN)	10.5	16.7	16.7
Basic static load rating C_{0a} (kN)	19	38	38
Preload torque (N-m)	4.9×10^2 to 2.2×10^1	—	—
Spacer ball	1 : 1	None	None
Rigidity value (N/ μ m)	190	360	
Circulation method	End cap		

Unit: mm

	Runout of the screw shaft axis D	Runout of the nut circumference H	Flange mounting surface runout I	Runout of the thread groove surface J	Lead angle accuracy		Nut mass kg	Shaft mass kg/m	Permissible rotational speed min ⁻¹
					Representative travel distance error	Fluctuation			
	0.055	0.015	0.011	0.013	± 0.03	0.023	0.53	3.03	2,690
	0.07	0.03	0.018	0.02	Travel distance: $\pm 0.05/300$		0.53	3.03	2,690
	0.065	0.015	0.011	0.013	± 0.035	0.025	0.53	3.03	2,690
	0.085	0.03	0.018	0.02	Travel distance: $\pm 0.05/300$		0.53	3.03	2,690
	0.085	0.015	0.011	0.013	± 0.04	0.027	0.53	3.03	2,690
	0.1	0.03	0.018	0.02	Travel distance: $\pm 0.05/300$		0.53	3.03	2,690
	0.11	0.015	0.011	0.013	± 0.046	0.03	0.53	3.03	2,690
	0.13	0.03	0.018	0.02	Travel distance: $\pm 0.05/300$		0.53	3.03	2,690
	0.11	0.015	0.011	0.013	± 0.054	0.035	0.53	3.03	2,690
	0.13	0.03	0.018	0.02	Travel distance: $\pm 0.05/300$		0.53	3.03	2,690
	0.14	0.015	0.011	0.013	± 0.054	0.035	0.53	3.03	2,690
	0.17	0.03	0.018	0.02	Travel distance: $\pm 0.05/300$		0.53	3.03	2,690
	0.14	0.015	0.011	0.013	± 0.065	0.04	0.53	3.03	2,690
	0.17	0.03	0.018	0.02	Travel distance: $\pm 0.05/300$		0.53	3.03	2,690

Ball Screw