

# HSR

## Global Standard LM Guide Model HSR

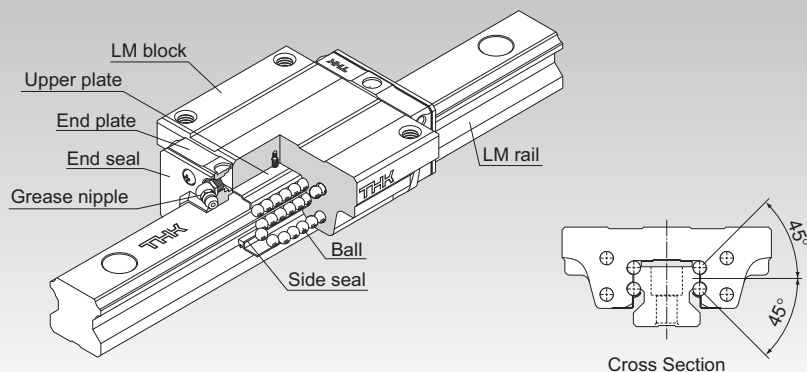

**Selection Criteria** **A1-10**

**Design Highlights** **A1-482**

**Options** **A1-507**

**Model No.** **A1-577**

**Handling Precautions** **A1-583**

**Accessories for Lubrication** **A24-1**

**Mounting Procedure** **B1-89**

Equivalent Moment Factor **A1-43**

Rated Loads in All Directions **A1-61**

Equivalent Factor in Each Direction **A1-63**

Radial Clearance **A1-74**

Accuracy Standards **A1-79**

Shoulder Height of the Mounting Base and the Corner Radius **A1-493**

Reference Error Tolerance for the Mounting Surface **A1-498**

Dimensions of Each Model with Options Attached **A1-521**

---

## Structure and Features

---

Balls roll in four rows of raceways precision-ground on an LM rail and an LM block, and end plates incorporated in the LM block allow the balls to circulate. Since retainer plates hold the balls, they will not fall out even if the LM block is removed from the LM rail (except models HSR 8X, 10X, and 12X). Each row of balls is placed at a contact angle of 45° so that the rated loads applied to the LM block are uniform in four directions (radial, reverse radial and lateral directions), enabling the LM Guide to be used in all orientations. In addition, the LM block can receive a well-balanced preload, increasing the rigidity in the four directions while maintaining a constant, low friction coefficient. The low height of the LM block makes it highly rigid, achieving stable, high-precision linear motion.

### 4-Way Equal Load

Each row of balls is placed at a contact angle of 45° so that the rated loads applied to the LM block are uniform in the four directions (radial, reverse-radial, and lateral directions), enabling the LM Guide to be used in all orientations.

### High Rigidity

Since the balls are well balanced in four rows, a large preload can be applied and the rigidity in four directions can easily be increased.

### Self-Adjustment Capability

The self-adjustment capability through the front-to-front configuration of THK's unique circular-arc grooves (DF set) enables mounting error to be absorbed even under a preload, thus achieving highly accurate and smooth linear motion.

### High Durability

Balls do not undergo differential slip, even under a preload or excessive biased load, allowing for smooth motion. Due to the product's high wear resistance, it maintains long-term accuracy.

### Stainless Steel Type also Available

A special type whose LM block, LM rail, and balls are made of stainless steel is also available.

## Types

### Model HSR-XSC

This type has a shorter overall LM block length (L) than the Model HSR-XC.

Dimensional Table⇒ **A1-190**

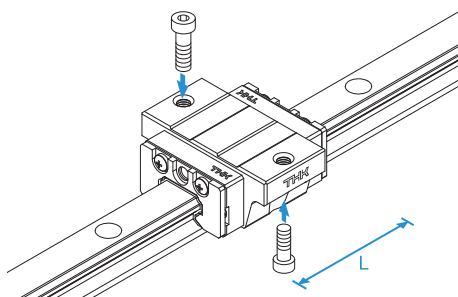

### Models HSR-C/XC

The flange of the LM block has tapped holes. This type can be mounted from the top or the bottom. It is used in places where the table cannot have through holes for mounting bolts.

Dimensional Table⇒ **A1-190**

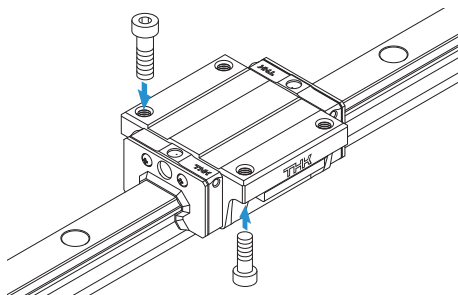

### Models HSR-LC/XLC

The LM block has the same cross-sectional shape as model HSR-C, but has a longer overall LM block length (L) and a greater load rating.

Dimensional Table⇒ **A1-190**

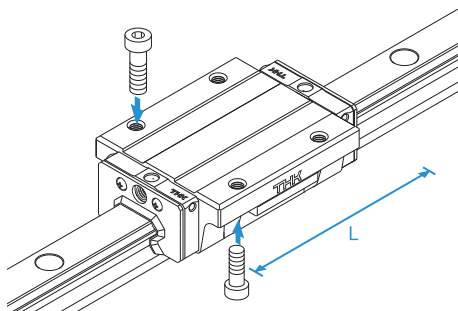

## Model HSR-XSR

This type has a shorter overall LM block length (L) than the Model HSR-XR.

Dimensional Table⇒ **A1-194**

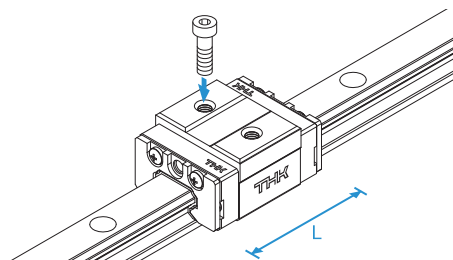

## Models HSR-R/XR

With this type, the LM block has a smaller width (W) and tapped holes. It is used in places where the space for table width is limited.

Dimensional Table⇒ **A1-194**

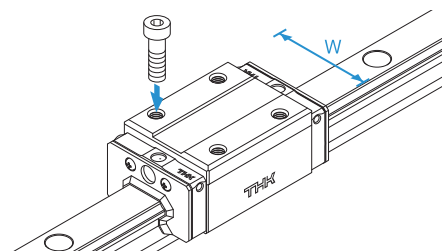

## Models HSR-LR/XLR

The LM block has the same cross-sectional shape as model HSR-R, but has a longer overall LM block length (L) and a greater load rating.

Dimensional Table⇒ **A1-194**

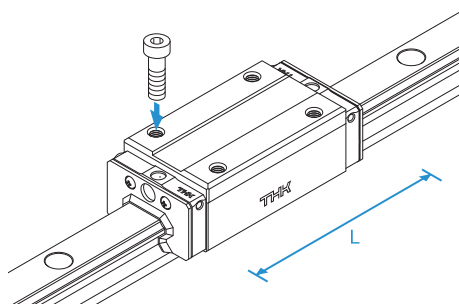

## Models HSR-YR/XYR

If using two conventional LM Guide units facing each other, it takes a long time to machine the table, and is difficult to achieve the desired accuracy and adjust the clearance. With the Model HSR-YR and Model HSR-XYR, the tapped holes on the side of the LM block simplify the structure, which drastically reduces labor time and increases accuracy.

Dimensional Table⇒ **A1-198**

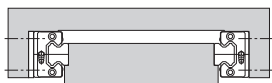
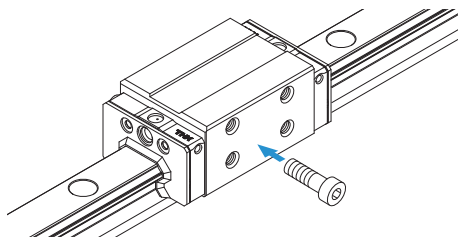

Fig. 1: Conventional Structure

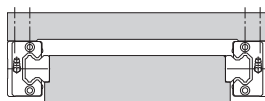
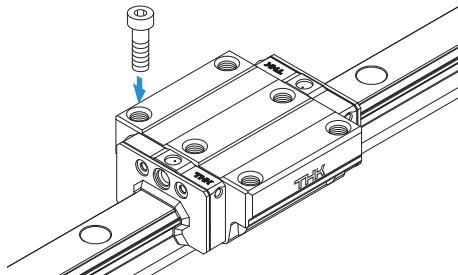

Fig. 2: Mounting Structure for Model HSR-YR

## Models HSR-CA/XCA

This model has six tapped holes on the LM block.

Dimensional Table⇒ **A1-200**



## Models HSR-HA/XHA

The LM block has the same cross-sectional shape as the Model HSR-CA, but it has a longer overall LM block length (L) and a greater load rating.

Dimensional Table⇒ **A1-200**

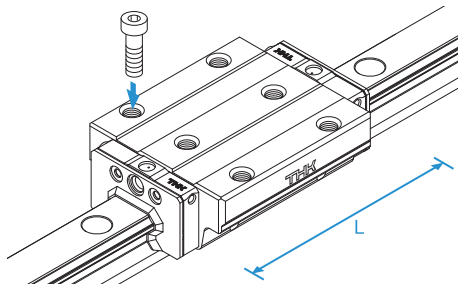

## Models HSR-CB/XCB

The LM block has six through holes. It is used in places where the table cannot have through holes for mounting bolts.

Dimensional Table⇒ **A1-202**

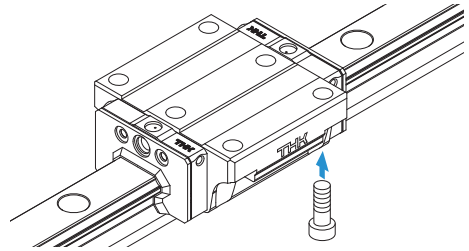

LM Guide

## Models HSR-HB/XHB

The LM block has the same cross sectional shape as model HSR-CB, but has a longer overall LM block length (L) and a greater load rating.

Dimensional Table⇒ **A1-202**

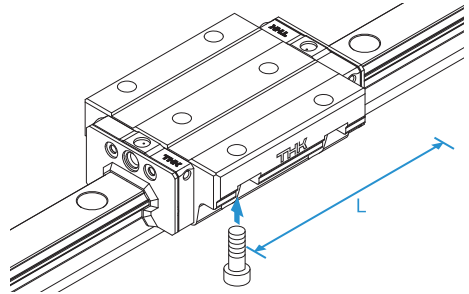

## Model HSR85A

The flange of its LM block has tapped holes.

Dimensional Table⇒ **A1-204**

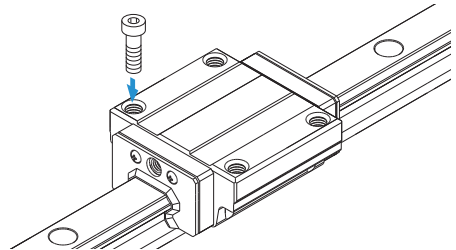

## Model HSR85LA

The LM block has the same cross-sectional shape as model HSR85A, but has a longer overall LM block length (L) and a greater load rating.

Dimensional Table⇒ **A1-204**

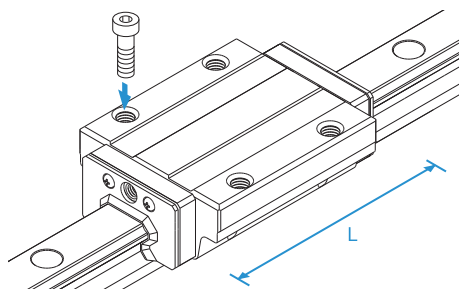

## Model HSR85B

The flange of the LM block has through holes. It is used in places where the table cannot have through holes for mounting bolts.

Dimensional Table⇒ **A1-204**

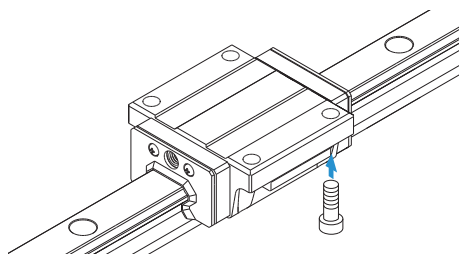

## Model HSR85LB

The LM block has the same cross-sectional shape as model HSR85B, but has a longer overall LM block length (L) and a greater load rating.

Dimensional Table⇒ **A1-204**

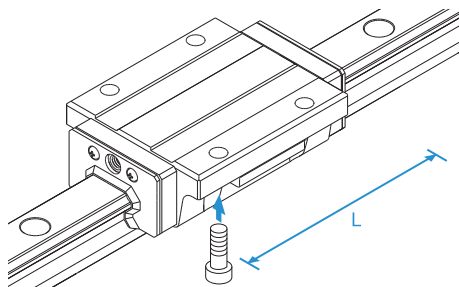

## Models HSR 100/120/150 HA/HB/HR

Dimensional Table → **A1-206**

These are large types of model HSR that can be used in large-scale machine tools and building structures.

Models HSR100/120/150HA/HB have nine tapped holes on the LM block. Models HSR100/120/150HR have six tapped holes on the LM block.

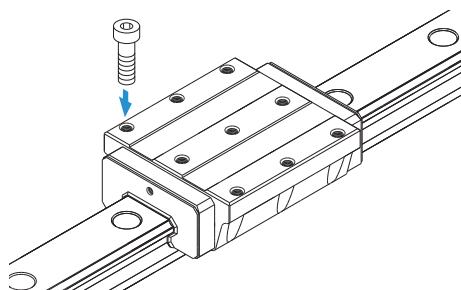

LM Guide

# Models HSR-XSCM, HSR-XCM, and HSR-XLCM

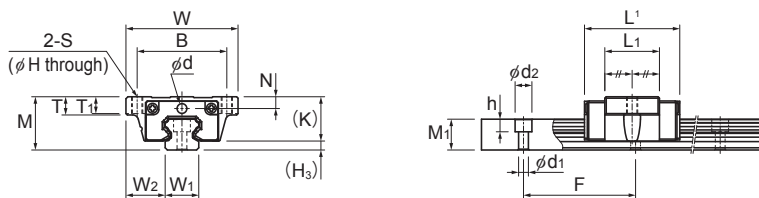

Models HSR8X SCM and 10X SCM

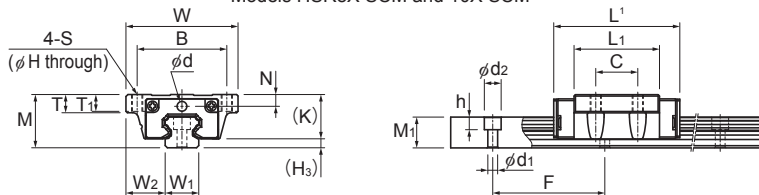

Models HSR8X CM/LCM and 10X CM/LCM

Model No.	Outer dimensions			LM block dimensions													Grease nipple	H <sub>3</sub>
	Height	Width	Length <sup>1</sup>	B	C	Mounting hole	H	L <sub>1</sub>	T	T <sub>1</sub>	K	N	E	Lubrication hole	d			
	M	W	L	B	C	S	H	L <sub>1</sub>	T	T <sub>1</sub>	K	N	E	d		H <sub>3</sub>		
HSR 8XSCM HSR 8XCM HSR 8XLCM	10	24	18 24 30.5	19	— 10	M2.3	1.5	9 15 21.5	4	3.5	7.9	1.6	—	2.2	—	2.1		
HSR 10XSCM HSR 10XCM HSR 10XLCM	12	30	24 31 40	24	— 12 12	M3	2.5	13.1 20.1 29.1	5	4.5	9.8	2.5	—	2.2	—	2.2		
HSR 12XSCM HSR 12XCM HSR 12XLCM	19	40	34 45 58	32	— 15 15	M4	3.3	19.5 30.5 43.5	6.5	6	15.9	4.2	4	—	PB107	3.1		

## Model number coding

**HSR12X C 2 UU C1 M +670L H T M - II**

Model number

Type of LM block

Contamination protection accessory symbol

Stainless steel LM block

LM rail length (in mm)

Stainless steel LM rail

Symbol for No. of rails used on the same plane

No. of LM blocks used on the same rail

Radial clearance symbol  
Normal (No symbol)  
Light preload (C1)

Symbol for LM rail jointed use

Accuracy symbol  
Normal grade (No Symbol)/High accuracy grade (H)  
Precision grade (P)/Super precision grade (SP)

Notes: This model number indicates that a single-rail unit constitutes one set (i.e., required number of sets when 2 rails are used in parallel is 2 at a minimum).

See [A1-547](#) for contamination protection accessories, see [A1-74](#) for radial clearance symbol. See [A1-79](#) for accuracy symbol. See [A1-13](#) for symbol for number of rails used on the same plane.

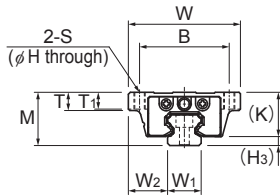

Model HSR12X SCM

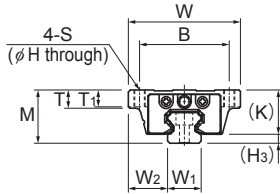
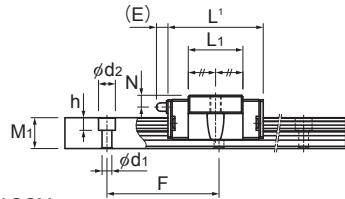

Models HSR12X CM/LCM

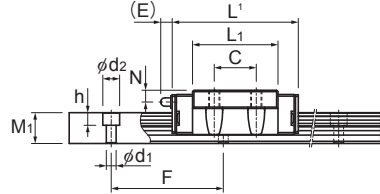

Unit: mm

	LM rail dimensions					Basic load rating		Static permissible moment $\text{kN}\cdot\text{m}^3$					Mass	
	Width	Height	Pitch	$d_1 \times d_2 \times h$	C	$C_0$	$M_A$		$M_B$		$M_C$	LM block	LM rail	
	$W_1$ $\pm 0.05$	$M_1$	F				1 block	2 blocks	1 block	2 blocks	1 block			kg
8	8	6	20	$2.4 \times 4.2 \times 2.3$	0.85 1.2 1.5	1.24 2.02 2.8	0.00179 0.00457 0.00913	0.0148 0.0297 0.0502	0.00179 0.00457 0.00913	0.0148 0.0297 0.0502	0.0043 0.00698 0.00964	0.007 0.013 0.018	0.3	
10	10	7	25	$3.5 \times 6 \times 3.3$	1.54 2.16 2.72	2.18 3.54 4.9	0.00464 0.0114 0.0211	0.0336 0.0659 0.115	0.00464 0.0114 0.0211	0.0336 0.0659 0.115	0.00949 0.0154 0.0213	0.017 0.026 0.038	0.45	
12	14	11	40	$3.5 \times 6 \times 4.5$	3.95 5.54 6.96	5.39 8.75 12.1	0.0171 0.0421 0.0781	0.116 0.234 0.409	0.0171 0.0421 0.0781	0.116 0.234 0.409	0.0277 0.0449 0.0622	0.059 0.092 0.132	0.83	

<sup>1</sup> Length L shown in the table is the length with the contamination protection accessories, code UU or SS.  
If other contamination protection accessories or lubricant equipment are installed, the total block length will increase. (See [A1-521](#) or [A1-543](#))

<sup>2</sup> The maximum length indicates the standard maximum length of an LM rail. (See [A1-208](#).)

<sup>3</sup> Static permissible moment 1 block: the static permissible moment with one LM block  
2 blocks: the static permissible moment with two LM blocks in close contact with each other

Notes: The M in the model number symbol indicates that the LM block, LM rail and balls are made of stainless steel.  
The stainless steel provides excellent corrosion and environmental resistance.

# Models HSR-C, HSR-CM, HSR-LC, HSR-LCM, HSR-XC, and HSR-XLC

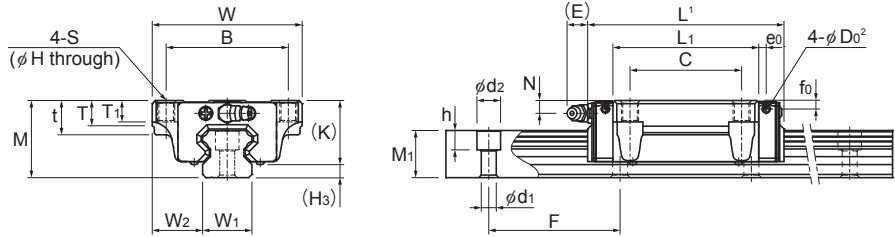

Models HSR15 to 35C/LC/CM/LCM

Model No.	Outer dimensions			LM block dimensions											Pilot hole for side nipple				
	Height	Width	Length <sup>1</sup>	B	C	S	H	L <sub>1</sub>	t	T	T <sub>1</sub>	K	N	E	Grease nipple	e <sub>0</sub>	f <sub>0</sub>	D <sub>0</sub> <sup>2</sup>	H <sub>3</sub>
	M	W	L																
HSR 15C HSR 15CM	24	47	56.6	38	30	M5	4.4	38.8	11	7	7	19.3	4.3	5.5	PB1021B	3.2	3.9	3	4.7
HSR 15LC HSR 15LCM	24	47	74.6	38	30	M5	4.4	56.8	11	7	7	19.3	4.3	5.5	PB1021B	3.2	3.9	3	4.7
HSR 20C HSR 20CM	30	63	74	53	40	M6	5.4	50.8	10	9.5	10	26	5	12	B-M6F	3.1	3.4	3	4
HSR 20LC HSR 20LCM	30	63	90	53	40	M6	5.4	66.8	10	9.5	10	26	5	12	B-M6F	3.1	3.4	3	4
HSR 25C HSR 25CM	36	70	83.1	57	45	M8	6.8	59.5	16	11	10	30.5	6	12	B-M6F	3.5	4	3	5.5
HSR 25LC HSR 25LCM	36	70	102.2	57	45	M8	6.8	78.6	16	11	10	30.5	6	12	B-M6F	3.5	4	3	5.5
HSR 30C HSR 30CM	42	90	98	72	52	M10	8.5	70.4	18	9	10	35	7	12	B-M6F	5.2	6.2	5.2	7
HSR 30LC HSR 30LCM	42	90	120.6	72	52	M10	8.5	93	18	9	10	35	7	12	B-M6F	5.2	6.2	5.2	7
HSR 35C HSR 35CM	48	100	109.4	82	62	M10	8.5	80.4	21	12	13	40.5	8	12	B-M6F	5.5	5.6	5.2	7.5
HSR 35LC HSR 35LCM	48	100	134.8	82	62	M10	8.5	105.8	21	12	13	40.5	8	12	B-M6F	5.5	5.6	5.2	7.5
HSR 45C HSR 45LC	60	120	138.9 170.7	100	80	M12	10.5	98 129.8	25	13	15	50	10	16	B-PT1/8	6.1	6.6	5.2	10
HSR 55C HSR 55LC	70	140	162.9 201	116	95	M14	12.5	118 156.1	29	13.5	17	57	11	16	B-PT1/8	5.6	7.7	5.2	13
HSR 65XC HSR 65XLC	90	170	190.5 250	142	110	M16	14.5	138.5 198	37	21.5	23	76	19	16	B-PT1/8	6.8	14.6	5.2	14

## Model number coding

### HSR25 C 2 QZ UU C0 M +1240L P T M - II

Model number	Type of LM block	With QZ Lubricator	Contamination protection accessory symbol	Stainless steel LM block	LM rail length (in mm)	Stainless steel LM rail jointed use	Symbol for No. of rails used on the same plane
HSR25	C	2	QZ	UU	C0	M	+1240L P T M - II
Model number	Type of LM block	With QZ Lubricator	Contamination protection accessory symbol	Stainless steel LM block	LM rail length (in mm)	Stainless steel LM rail jointed use	Symbol for No. of rails used on the same plane
		No. of LM blocks used on the same rail	Radial clearance symbol Normal (No symbol) Light preload (C1) Medium preload (C0)			Accuracy symbol Normal grade (No Symbol)/High accuracy grade (H) Precision grade (P)/Super precision grade (SP) Ultra precision grade (UP)	

Notes: This model number indicates that a single-rail unit constitutes one set (i.e., required number of sets when 2 rails are used in parallel is 2 at a minimum). Grease nipples are not installed when there is a QZ Lubricator. Contact THK if you want to use a grease nipple for a model with a QZ. See **A1-547** for contamination protection accessories, see **A1-74** for radial clearance symbol. See **A1-79** for accuracy symbol. See **A1-13** for symbol for number of rails used on the same plane.

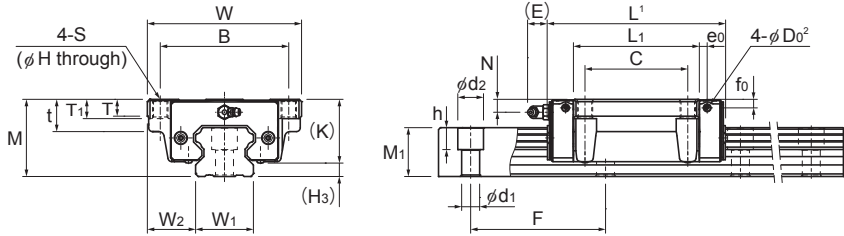

Models HSR45 to 65C/LC/XC/XLC

Unit: mm

LM rail dimensions						Basic load rating		Static permissible moment kN·m <sup>-1</sup>					Mass	
Width W <sub>1</sub> ±0.05	W <sub>2</sub>	Height M <sub>1</sub>	Pitch F	d <sub>1</sub> × d <sub>2</sub> × h	Length <sup>3</sup> Max	C kN	C <sub>0</sub> kN	M <sub>A</sub>		M <sub>B</sub>		M <sub>C</sub>	LM block kg	LM rail kg/m
								1 block	2 blocks	1 block	2 blocks	1 block		
15	16	15	60	4.5 × 7.5 × 5.3	3000 (1240)	10.9	15.7	0.0945	0.527	0.0945	0.527	0.0998	0.2	1.5
15	16	15	60	4.5 × 7.5 × 5.3	3000 (1240)	14.2	22.9	0.194	0.984	0.194	0.984	0.145	0.29	1.5
20	21.5	18	60	6 × 9.5 × 8.5	3000 (1480)	19.8	27.4	0.218	1.2	0.218	1.2	0.235	0.35	2.3
20	21.5	18	60	6 × 9.5 × 8.5	3000 (1480)	23.9	35.8	0.363	1.87	0.363	1.87	0.307	0.47	2.3
23	23.5	22	60	7 × 11 × 9	3000 (2020)	27.6	36.4	0.324	1.8	0.324	1.8	0.366	0.59	3.3
23	23.5	22	60	7 × 11 × 9	3000 (2020)	35.2	51.6	0.627	3.04	0.627	3.04	0.518	0.75	3.3
28	31	26	80	9 × 14 × 12	3000 (2520)	40.5	53.7	0.599	3.1	0.599	3.1	0.652	1.1	4.8
28	31	26	80	9 × 14 × 12	3000 (2520)	48.9	70.2	0.995	4.89	0.995	4.89	0.852	1.3	4.8
34	33	29	80	9 × 14 × 12	3000 (2520)	53.9	70.2	0.895	4.51	0.895	4.51	1.05	1.6	6.6
34	33	29	80	9 × 14 × 12	3000 (2520)	65	91.7	1.49	7.13	1.49	7.13	1.37	2.0	6.6
45	37.5	38	105	14 × 20 × 17	3090	82.2 100	101 135	1.5 2.59	8.37 13.4	1.5 2.59	8.37 13.4	1.94 2.6	2.8 3.3	11 11
53	43.5	44	120	16 × 23 × 20	3060	121 148	146 194	2.6 4.46	14.1 22.7	2.6 4.46	14.1 22.7	3.43 4.56	4.5 5.7	15.1 15.1
63	53.5	53	150	18 × 26 × 22	3000	195 249	228 323	5.08 9.81	25 45.6	5.08 9.81	25 45.6	6.2 8.79	8.5 10.7	22.5 22.5

<sup>1</sup> Length L shown in the table is the length with the contamination protection accessories, code UU or SS.

If other contamination protection accessories or lubricant equipment are installed, the total block length will increase. (See [A1-521](#) or [A1-543](#))

<sup>2</sup> D<sub>0</sub> are the pilot holes for when a grease nipple is desired for a product with LaCS or a QZ Lubricator.

Pilot holes are not drilled through for models other than those stated above.

For grease nipple mount machining, contact THK.

<sup>3</sup> The maximum length indicates the standard maximum length of an LM rail. (See [A1-208](#).)

<sup>4</sup> Static permissible moment 1 block: the static permissible moment with one LM block

2 blocks: the static permissible moment with two LM blocks in close contact with each other

Notes: The M in the model number symbol indicates that the LM block, LM rail and balls are made of stainless steel.

The stainless steel provides excellent corrosion and environmental resistance.

## Models HSR-XSRM, HSR-XRM, and HSR-XLRM

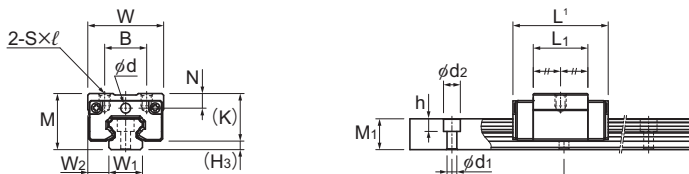

Models HSR8X SRM and 10X SRM

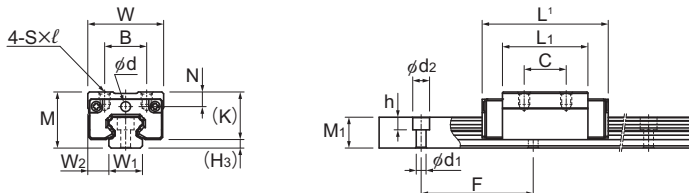

Models HSR8X RM/LRM and 10X RM/LRM

Model No.	Outer dimensions			LM block dimensions											Grease nipple	H <sub>3</sub>
	Height	Width	Length <sup>1</sup>	B	C	S × ℓ	L <sub>1</sub>	T	K	N	E	Lubrication hole d				
	M	W	L													
HSR 8XSRM HSR 8XRM HSR 8XLRM	11	16	18 24 30.5	10	— 10 10	M2×2.5	9 15 21.5	—	8.9	2.6	—	2.2	—	2.1		
HSR 10XSRM HSR 10XRM HSR 10XLRM	13	20	24 31 40	13	— 12 12	M2.6×2.5	13.1 20.1 29.1	—	10.8	3.5	—	2.2	—	2.2		
HSR 12XSRM HSR 12XRM HSR 12XLRM	20	27	34 45 58	15	— 15 15	M4×4.5	19.5 30.5 43.5	6	16.9	5.2	4	—	PB107	3.1		

### Model number coding

**HSR12X R 2 UU C1 M +670L H T M - II**

Model number

Type of LM block

Contamination protection accessory symbol

Stainless steel LM block

LM rail length (in mm)

Stainless steel LM rail

Symbol for No. of rails used on the same plane

No. of LM blocks used on the same rail

Radial clearance symbol  
Normal (No symbol)  
Light preload (C1)

Symbol for LM rail jointed use

Accuracy symbol

Normal grade (No Symbol)/High accuracy grade (H)  
Precision grade (P)/Super precision grade (SP)

Notes: This model number indicates that a single-rail unit constitutes one set (i.e., required number of sets when 2 rails are used in parallel is 2 at a minimum).

See **A1-547** for contamination protection accessories, see **A1-74** for radial clearance symbol. See **A1-79** for accuracy symbol. See **A1-13** for symbol for number of rails used on the same plane.

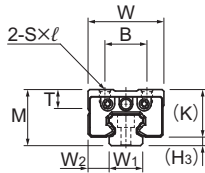

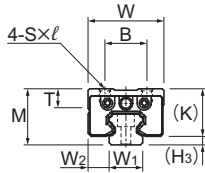
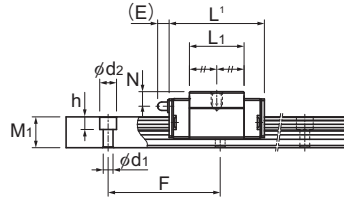

Model HSR12X SRM

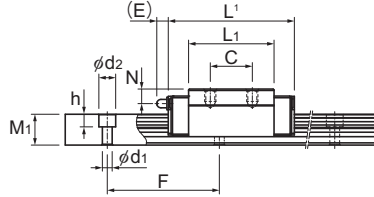

Models HSR12X RM/LRM



Unit: mm

	LM rail dimensions					Basic load rating		Static permissible moment kN·m <sup>3</sup>					Mass	
	Width W <sub>1</sub> ±0.05	Height W <sub>2</sub>	Pitch M <sub>1</sub>	Pitch F	d <sub>1</sub> × d <sub>2</sub> × h	C kN	C <sub>0</sub> kN	M <sub>A</sub> 		M <sub>B</sub> 		M <sub>C</sub> 	LM block kg	LM rail kg/m
								1 block	2 blocks	1 block	2 blocks	1 block		
8	4	6	20	2.4 × 4.2 × 2.3	0.85 1.2 1.5	1.24 2.02 2.8	0.00179 0.00457 0.00913	0.0148 0.0297 0.0502	0.00179 0.00457 0.00913	0.0148 0.0297 0.0502	0.0043 0.00698 0.00964	0.006 0.01 0.015	0.3	
10	5	7	25	3.5 × 6 × 3.3	1.54 2.16 2.72	2.18 3.54 4.9	0.00464 0.0114 0.0211	0.0336 0.0659 0.115	0.00464 0.0114 0.0211	0.0336 0.0659 0.115	0.00949 0.0154 0.0213	0.014 0.021 0.031	0.45	
12	7.5	11	40	3.5 × 6 × 4.5	3.95 5.54 6.96	5.39 8.75 12.1	0.0171 0.0421 0.0781	0.116 0.234 0.409	0.0171 0.0421 0.0781	0.116 0.234 0.409	0.0277 0.0449 0.0622	0.045 0.071 0.102	0.83	

<sup>1</sup> Length L shown in the table is the length with the contamination protection accessories, code UU or SS.

If other contamination protection accessories or lubricant equipment are installed, the total block length will increase. (See **A1-521** or **A1-543**)

<sup>2</sup> The maximum length indicates the standard maximum length of an LM rail. (See **A1-208**.)

<sup>3</sup> Static permissible moment 1 block: the static permissible moment with one LM block

2 blocks: the static permissible moment with two LM blocks in close contact with each other

Notes: The M in the model number symbol indicates that the LM block, LM rail and balls are made of stainless steel.

The stainless steel provides excellent corrosion and environmental resistance.

# Models HSR-R, HSR-RM, HSR-LR, HSR-LRM, HSR-XR, and HSR-XLR

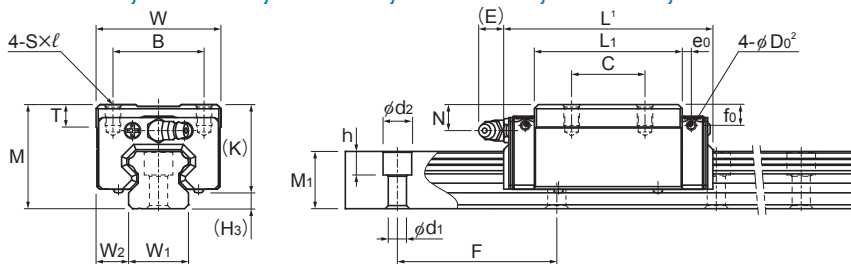

Models HSR15 to 35R/LR/RM/LRM

Model No.	Outer dimensions			LM block dimensions										Pilot hole for side nipple			H <sub>3</sub>
	Height	Width	Length <sup>1</sup>	B	C	S × l	L <sub>1</sub>	T	K	N	E	Grease nipple	e <sub>0</sub>	f <sub>0</sub>	D <sub>0</sub> <sup>2</sup>		
	M	W	L														
HSR 15R HSR 15RM	28	34	56.6	26	26	M4 × 5	38.8	6	23.3	8.3	5.5	PB1021B	3.2	7.9	3	4.7	
HSR 15LR HSR 15LRM	28	34	74.6	26	34	M4 × 5	56.8	6	23.3	8.3	5.5	PB1021B	3.2	7.9	3	4.7	
HSR 20R HSR 20RM	30	44	74	32	36	M5 × 6	50.8	8	26	5	12	B-M6F	3.1	3.4	3	4	
HSR 20LR HSR 20LRM	30	44	90	32	50	M5 × 6	66.8	8	26	5	12	B-M6F	3.1	3.4	3	4	
HSR 25R HSR 25RM	40	48	83.1	35	35	M6 × 8	59.5	9	34.5	10	12	B-M6F	3.5	8	3	5.5	
HSR 25LR HSR 25LRM	40	48	102.2	35	50	M6 × 8	78.6	9	34.5	10	12	B-M6F	3.5	8	3	5.5	
HSR 30R HSR 30RM	45	60	98	40	40	M8 × 10	70.4	9	38	10	12	B-M6F	5.2	9.2	5.2	7	
HSR 30LR HSR 30LRM	45	60	120.6	40	60	M8 × 10	93	9	38	10	12	B-M6F	5.2	9.2	5.2	7	
HSR 35R HSR 35RM	55	70	109.4	50	50	M8 × 12	80.4	11.7	47.5	15	12	B-M6F	5.5	12.6	5.2	7.5	
HSR 35LR HSR 35LRM	55	70	134.8	50	72	M8 × 12	105.8	11.7	47.5	15	12	B-M6F	5.5	12.6	5.2	7.5	
HSR 45R HSR 45LR	70	86	138.9 170.7	60	60 80	M10 × 17	98 129.8	15	60	20	16	B-PT1/8	6.1	16.6	5.2	10	
HSR 55R HSR 55LR	80	100	162.9 201	75	75 95	M12 × 18	118 156.1	20.5	67	21	16	B-PT1/8	5.6	17.7	5.2	13	
HSR 65XR HSR 65XLR	90	126	190.5 250	76	70 120	M16 × 20	138.5 198	23	76	19	16	B-PT1/8	6.8	14.6	5.2	14	
HSR 85R HSR 85LR	110	156	245.6 303	100	80 140	M18 × 25	178.6 236	29	94	23	16	B-PT1/8	—	—	—	16	

## Model number coding

### HSR35 R 2 QZ SS C0 M +1400L P T M - II

Model number	Type of LM block	With QZ Lubricator	Contamination protection accessory symbol	Stainless steel LM block	LM rail length (in mm)	Stainless steel LM rail	Symbol for LM rail jointed use	Symbol for No. of rails used on the same plane
	No. of LM blocks used on the same rail		Radial clearance symbol Normal (No symbol) Light preload (C1) Medium preload (C0)		Accuracy symbol Normal grade (No Symbol)/High accuracy grade (H) Precision grade (P)/Super precision grade (SP) Ultra precision grade (UP)			

Notes: This model number indicates that a single-rail unit constitutes one set (i.e., required number of sets when 2 rails are used in parallel is 2 at a minimum). Grease nipples are not installed when there is a QZ Lubricator. Contact THK if you want to use a grease nipple for a model with a QZ. See [A1-547](#) for contamination protection accessories, see [A1-74](#) for radial clearance symbol. See [A1-79](#) for accuracy symbol. See [A1-13](#) for symbol for number of rails used on the same plane.

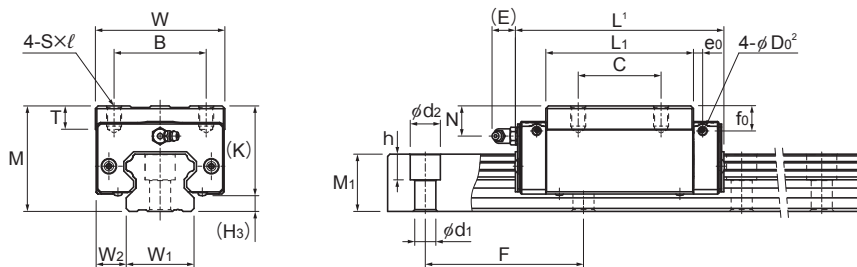

Models HSR45 to 85R/LR/XR/XLR

Unit: mm

LM rail dimensions						Basic load rating		Static permissible moment kN·m <sup>4</sup>					Mass	
Width W <sub>1</sub> ±0.05	W <sub>2</sub>	Height M <sub>1</sub>	Pitch F	Pitch d <sub>1</sub> × d <sub>2</sub> × h	Length <sup>3</sup> Max	C kN	C <sub>0</sub> kN	M <sub>a</sub>		M <sub>b</sub>		M <sub>c</sub>	LM block kg	LM rail kg/m
								1 block	2 blocks	1 block	2 blocks	1 block		
15	9.5	15	60	4.5 × 7.5 × 5.3	3000 (1240)	10.9	15.7	0.0945	0.527	0.0945	0.527	0.0998	0.18	1.5
15	9.5	15	60	4.5 × 7.5 × 5.3	3000 (1240)	14.2	22.9	0.194	0.984	0.194	0.984	0.145	0.26	1.5
20	12	18	60	6 × 9.5 × 8.5	3000 (1480)	19.8	27.4	0.218	1.2	0.218	1.2	0.235	0.25	2.3
20	12	18	60	6 × 9.5 × 8.5	3000 (1480)	23.9	35.8	0.363	1.87	0.363	1.87	0.307	0.35	2.3
23	12.5	22	60	7 × 11 × 9	3000 (2020)	27.6	36.4	0.324	1.8	0.324	1.8	0.366	0.54	3.3
23	12.5	22	60	7 × 11 × 9	3000 (2020)	35.2	51.6	0.627	3.04	0.627	3.04	0.518	0.67	3.3
28	16	26	80	9 × 14 × 12	3000 (2520)	40.5	53.7	0.599	3.1	0.599	3.1	0.652	0.9	4.8
28	16	26	80	9 × 14 × 12	3000 (2520)	48.9	70.2	0.995	4.89	0.995	4.89	0.852	1.1	4.8
34	18	29	80	9 × 14 × 12	3000 (2520)	53.9	70.2	0.895	4.51	0.895	4.51	1.05	1.5	6.6
34	18	29	80	9 × 14 × 12	3000 (2520)	65	91.7	1.49	7.13	1.49	7.13	1.37	2	6.6
45	20.5	38	105	14 × 20 × 17	3090	82.2 100	101 135	1.5 2.59	8.37 13.4	1.5 2.59	8.37 13.4	1.94 2.6	2.6 3.1	11
53	23.5	44	120	16 × 23 × 20	3060	121 148	146 194	2.6 4.46	14.1 22.7	2.6 4.46	14.1 22.7	3.43 4.56	4.3 5.4	15.1
63	31.5	53	150	18 × 26 × 22	3000	195 249	228 323	5.08 9.81	25 45.6	5.08 9.81	25 45.6	6.2 8.79	7.3 9.7	22.5 22.5
85	35.5	65	180	24 × 35 × 28	3000	304 367	355 464	10.2 16.9	51.2 81	10.2 16.9	51.2 81	12.8 16.7	13 16	35.2

<sup>1</sup> Length L shown in the table is the length with the contamination protection accessories, code UU or SS.

If other contamination protection accessories or lubricant equipment are installed, the total block length will increase. (See **A1-521** or **A1-543**)

<sup>2</sup> D<sub>0</sub> are the pilot holes for when a grease nipple is desired for a product with InaCS or a QZ Lubricator.

Pilot holes are not drilled through for models other than those stated above.

For grease nipple mount machining, contact THK.

<sup>3</sup> The maximum length indicates the standard maximum length of an LM rail. (See **A1-208**.)

<sup>4</sup> Static permissible moment 1 block: the static permissible moment with one LM block

2 blocks: the static permissible moment with two LM blocks in close contact with each other

Notes: The M in the model number symbol indicates that the LM block, LM rail and balls are made of stainless steel.

The stainless steel provides excellent corrosion and environmental resistance.

# Models HSR-YR, HSR-YRM, and HSR-XYR

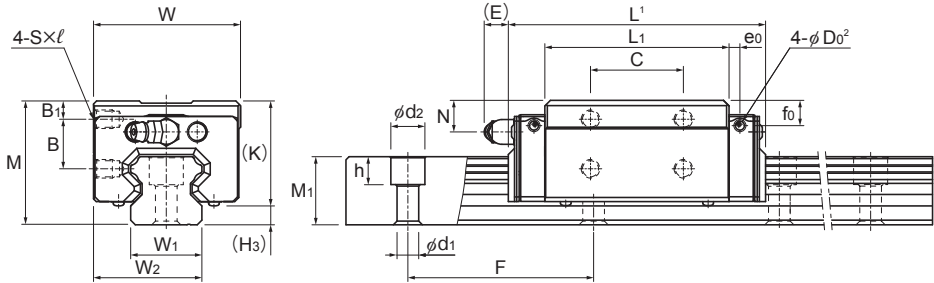

Models HSR15 to 35YR/YRM

Model No.	Outer dimensions			LM block dimensions										Pilot hole for side nipple			H <sub>3</sub>
	Height M	Width W	Length <sup>1</sup> L	B <sub>1</sub>	B	C	S × l	L <sub>1</sub>	K	N	E	Grease nipple	e <sub>0</sub>	f <sub>0</sub>	D <sub>0</sub> <sup>2</sup>		
HSR 15YR HSR 15YRM	28	33.5	56.6	4.3	11.5	18	M4 × 5	38.8	23.3	8.3	5.5	PB1021B	3.2	7.9	3	4.7	
HSR 20YR HSR 20YRM	30	43.5	74	4	11.5	25	M5 × 6	50.8	26	5	12	B-M6F	3.1	3.4	3	4	
HSR 25YR HSR 25YRM	40	47.5	83.1	6	16	30	M6 × 6	59.5	34.5	10	12	B-M6F	3.5	8	3	5.5	
HSR 30YR HSR 30YRM	45	59.5	98	8	16	40	M6 × 9	70.4	38	10	12	B-M6F	5.2	9.2	5.2	7	
HSR 35YR HSR 35YRM	55	69.5	109.4	8	23	43	M8 × 10	80.4	47.5	15	12	B-M6F	5.5	12.6	5.2	7.5	
HSR 45XYR	70	85.5	138.9	10	30	55	M10 × 12	98	60	20	16	B-PT1/8	6.1	16.6	5.2	10	
HSR 45YR	70	85.5	138.9	10	30	55	M10 × 14	98	60	20	16	B-PT1/8	—	—	—	10	
HSR 55XYR	80	99.5	162.9	12	32	70	M12 × 13	118	67	21	16	B-PT1/8	5.6	17.7	5.2	13	
HSR 55YR	80	99.5	162.9	12	32	70	M12 × 15	118	67	21	16	B-PT1/8	—	—	—	13	
HSR 65XYR	90	124.5	190.5	12	35	85	M16 × 18	138.5	76	19	16	B-PT1/8	6.8	14.6	5.2	14	

## Model number coding

**HSR25 YR 2 UU C0 M +1240L P T M -II**

Model number

Type of LM block

No. of LM blocks used on the same rail

Contamination protection accessory symbol

Radial clearance symbol  
Normal (No symbol)  
Light preload (C1)  
Medium preload (C0)

Stainless steel LM block

LM rail length (in mm)

Accuracy symbol  
Normal grade (No Symbol)/High accuracy grade (H)  
Precision grade (P)/Super precision grade (SP)  
Ultra precision grade (UP)

Stainless steel LM rail

Symbol for LM rail jointed use

Symbol for No. of rails used on the same plane

Notes: This model number indicates that a single-rail unit constitutes one set (i.e., required number of sets when 2 rails are used in parallel is 2 at a minimum).

Grease nipples are not installed when there is a QZ Lubricator. Contact THK if you want to use a grease nipple for a model with a QZ. See **A1-547** for contamination protection accessories, see **A1-74** for radial clearance symbol. See **A1-79** for accuracy symbol. See **A1-13** for symbol for number of rails used on the same plane.

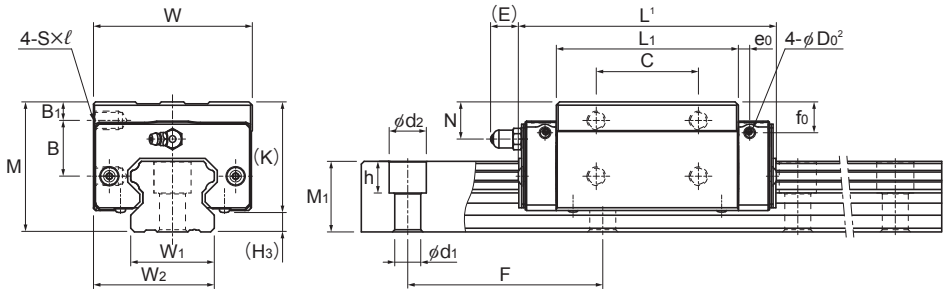

Models HSR45 to 65YR/XYR

Unit: mm

LM rail dimensions						Basic load rating		Static permissible moment kN·m <sup>4</sup>					Mass	
Width $W_1$ ±0.05	$W_2$	Height $M_1$	Pitch $F$	$d_1 \times d_2 \times h$	Length <sup>3</sup> Max	$C$ kN	$C_0$ kN	$M_A$		$M_B$		$M_C$	LM block kg	LM rail kg/m
								1 block	2 blocks	1 block	2 blocks	1 block		
15	24	15	60	4.5×7.5×5.3	3000 (1240)	10.9	15.7	0.0945	0.527	0.0945	0.527	0.0998	0.18	1.5
20	31.5	18	60	6×9.5×8.5	3000 (1480)	19.8	27.4	0.218	1.2	0.218	1.2	0.235	0.25	2.3
23	35	22	60	7×11×9	3000 (2020)	27.6	36.4	0.324	1.8	0.324	1.8	0.366	0.54	3.3
28	43.5	26	80	9×14×12	3000 (2520)	40.5	53.7	0.599	3.1	0.599	3.1	0.652	0.9	4.8
34	51.5	29	80	9×14×12	3000 (2520)	53.9	70.2	0.895	4.51	0.895	4.51	1.05	1.5	6.6
45	65	38	105	14×20×17	3090	82.2	101	1.5	8.37	1.5	8.37	1.94	2.6	11
45	65	38	105	14×20×17	3090	82.2	101	1.5	8.37	1.5	8.37	1.94	2.6	11
53	76	44	120	16×23×20	3060	121	146	2.6	14.1	2.6	14.1	3.43	4.3	15.1
53	76	44	120	16×23×20	3060	121	146	2.6	14.1	2.6	14.1	3.43	4.3	15.1
63	93	53	150	18×26×22	3000	195	228	5.08	25	5.08	25	6.2	7.3	22.5

<sup>1</sup> Length L shown in the table is the length with the contamination protection accessories, code UU or SS.

If other contamination protection accessories or lubricant equipment are installed, the total block length will increase. (See [A1-521](#) or [A1-543](#).)

<sup>2</sup>  $D_0$  are the pilot holes for when a grease nipple is desired for a product with LaCS or a QZ Lubricator.

Pilot holes are not drilled through for models other than those stated above.

For grease nipple mount machining, contact THK.

<sup>3</sup> The maximum length indicates the standard maximum length of an LM rail. (See [A1-208](#).)

<sup>4</sup> Static permissible moment 1 block: the static permissible moment with one LM block

2 blocks: the static permissible moment with two LM blocks in close contact with each other

Notes: The M in the model number symbol indicates that the LM block, LM rail and balls are made of stainless steel.

The stainless steel provides excellent corrosion and environmental resistance.

See [A1-483](#) or [A1-485](#) for how to install models HSR-YR/YRM.

# Models HSR-CA, HSR-CAM, HSR-HA, HSR-HAM, HSR-XCA, and HSR-XHA

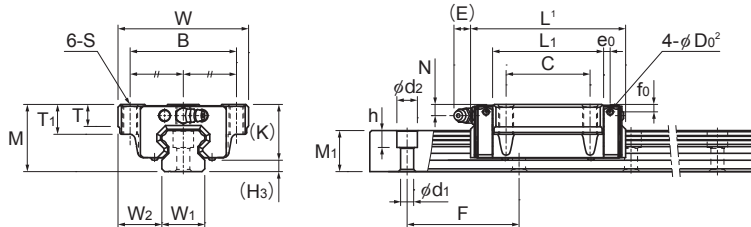

Models HSR20 to 35CA/HA/CAM/HAM

Model No.	Outer dimensions			LM block dimensions											Pilot hole for side nipple			H <sub>3</sub>
	Height	Width	Length <sup>1</sup>	B	C	S	L <sub>1</sub>	t	T	T <sub>1</sub>	K	N	E	Grease nipple	e <sub>0</sub>	f <sub>0</sub>	D <sub>0</sub> <sup>2</sup>	
	M	W	L															
HSR 20CA HSR 20CAM	30	63	74	53	40	M6	50.8	—	9.5	10	26	5	12	B-M6F	3.1	3.4	3	4
HSR 20HA HSR 20HAM	30	63	90	53	40	M6	66.8	—	9.5	10	26	5	12	B-M6F	3.1	3.4	3	4
HSR 25CA HSR 25CAM	36	70	83.1	57	45	M8	59.5	—	11	16	30.5	6	12	B-M6F	3.5	4	3	5.5
HSR 25HA HSR 25HAM	36	70	102.2	57	45	M8	78.6	—	11	16	30.5	6	12	B-M6F	3.5	4	3	5.5
HSR 30CA HSR 30CAM	42	90	98	72	52	M10	70.4	—	9	18	35	7	12	B-M6F	5.2	6.2	5.2	7
HSR 30HA HSR 30HAM	42	90	120.6	72	52	M10	93	—	9	18	35	7	12	B-M6F	5.2	6.2	5.2	7
HSR 35CA HSR 35CAM	48	100	109.4	82	62	M10	80.4	—	12	21	40.5	8	12	B-M6F	5.5	5.6	5.2	7.5
HSR 35HA HSR 35HAM	48	100	134.8	82	62	M10	105.8	—	12	21	40.5	8	12	B-M6F	5.5	5.6	5.2	7.5
HSR 45CA HSR 45HA	60	120	138.9 170.7	100	80	M12	98 129.8	25	13	15	50	10	16	B-PT1/8	6.1	6.6	5.2	10
HSR 55CA HSR 55HA	70	140	162.9 201	116	95	M14	118 156.1	29	13.5	17	57	11	16	B-PT1/8	5.6	7.7	5.2	13
HSR 65XCA HSR 65XHA	90	170	190.5 250	142	110	M16	138.5 198	37	21.5	23	76	19	16	B-PT1/8	6.8	14.6	5.2	14
HSR 85CA HSR 85HA	110	215	245.6 303	185	140	M20	178.6 236	55	28	30	94	23	16	B-PT1/8	—	—	—	16

## Model number coding

**HSR25 HA 2 QZ KKHH C0 M +1300L P T M -II**

Model number

Type of LM block

With QZ Lubricator

Contamination protection accessory symbol

Stainless steel LM block

LM rail length (in mm)

Accuracy symbol  
Normal grade (No Symbol)  
High accuracy grade (H)  
Precision grade (P)  
Super precision grade (SP)  
Ultra precision grade (UP)

Stainless steel LM rail

Symbol for LM rail jointed use

Symbol for No. of rails used on the same plane

No. of LM blocks used on the same rail

Radial clearance symbol  
Normal (No symbol)  
Light preload (C1)  
Medium preload (C0)

Notes: This model number indicates that a single-rail unit constitutes one set (i.e., required number of sets when 2 rails are used in parallel is 2 at a minimum).

Grease nipples are not installed when there is a QZ Lubricator. Contact THK if you want to use a grease nipple for a model with a QZ.

See [A1-547](#) for contamination protection accessories, see [A1-74](#) for radial clearance symbol. See [A1-79](#) for accuracy symbol. See [A1-13](#) for symbol for number of rails used on the same plane.

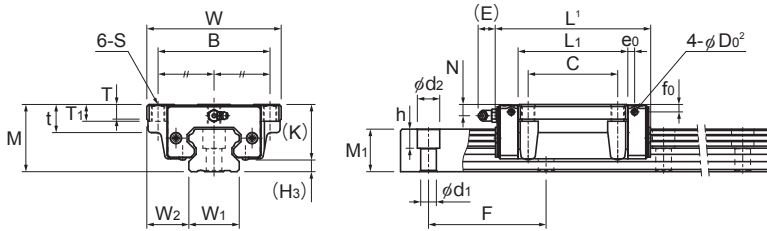

Models HSR45 to 85CA/HA/XCA/XHA

Unit: mm

LM rail dimensions							Basic load rating		Static permissible moment kN·m <sup>4</sup>					Mass	
Width W <sub>1</sub> ±0.05	W <sub>2</sub>	Height M <sub>1</sub>	Pitch F	Pitch d <sub>1</sub> × d <sub>2</sub> × h	Length <sup>3</sup> Max	C kN	C <sub>0</sub> kN	M <sub>A</sub>		M <sub>B</sub>		M <sub>C</sub>	LM block kg	LM rail kg/m	
								1 block	2 blocks	1 block	2 blocks	1 block			
20	21.5	18	60	6 × 9.5 × 8.5	3000 (1480)	19.8	27.4	0.218	1.2	0.218	1.2	0.235	0.35	2.3	
20	21.5	18	60	6 × 9.5 × 8.5	3000 (1480)	23.9	35.8	0.363	1.87	0.363	1.87	0.307	0.47	2.3	
23	23.5	22	60	7 × 11 × 9	3000 (2020)	27.6	36.4	0.324	1.8	0.324	1.8	0.366	0.59	3.3	
23	23.5	22	60	7 × 11 × 9	3000 (2020)	35.2	51.6	0.627	3.04	0.627	3.04	0.518	0.75	3.3	
28	31	26	80	9 × 14 × 12	3000 (2520)	40.5	53.7	0.599	3.1	0.599	3.1	0.652	1.1	4.8	
28	31	26	80	9 × 14 × 12	3000 (2520)	48.9	70.2	0.995	4.89	0.995	4.89	0.852	1.3	4.8	
34	33	29	80	9 × 14 × 12	3000 (2520)	53.9	70.2	0.895	4.51	0.895	4.51	1.05	1.6	6.6	
34	33	29	80	9 × 14 × 12	3000 (2520)	65	91.7	1.49	7.13	1.49	7.13	1.37	2	6.6	
45	37.5	38	105	14 × 20 × 17	3090	82.2 100	101 135	1.5 2.59	8.37 13.4	1.5 2.59	8.37 13.4	1.94 2.6	2.8 3.3	11	
53	43.5	44	120	16 × 23 × 20	3060	121 148	146 194	2.6 4.46	14.1 22.7	2.6 4.46	14.1 22.7	3.43 4.56	4.5 5.7	15.1	
63	53.5	53	150	18 × 26 × 22	3000	195 249	228 323	5.08 9.81	25 45.6	5.08 9.81	25 45.6	6.2 8.79	8.5 10.7	22.5	
85	65	65	180	24 × 35 × 28	3000	304 367	355 464	10.2 16.9	51.2 81	10.2 16.9	51.2 81	12.8 16.7	17 23	35.2	

<sup>1</sup> Length L shown in the table is the length with the contamination protection accessories, code UU or SS.

If other contamination protection accessories or lubricant equipment are installed, the total block length will increase. (See **A1-521** or **A1-543**)

<sup>2</sup> D<sub>0</sub> are the pilot holes for when a grease nipple is desired for a product with LaCS or a QZ Lubricator.

Pilot holes are not drilled through for models other than those stated above.

For grease nipple mount machining, contact THK.

<sup>3</sup> The maximum length indicates the standard maximum length of an LM rail. (See **A1-208**.)

<sup>4</sup> Static permissible moment 1 block: the static permissible moment with one LM block

2 blocks: the static permissible moment with two LM blocks in close contact with each other

Notes: The M in the model number symbol indicates that the LM block, LM rail and balls are made of stainless steel.

The stainless steel provides excellent corrosion and environmental resistance.

## Models HSR-CB, HSR-CBM, HSR-HB, HSR-HBM, HSR-XCB, and HSR-XHB

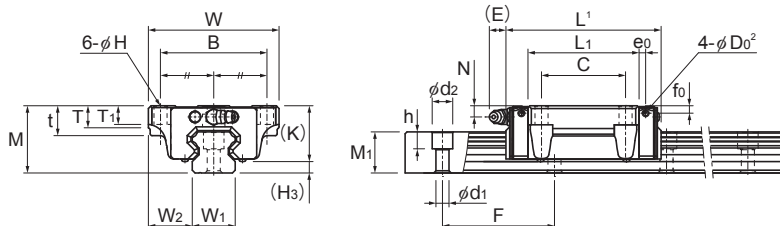

Models HSR20 to 35CB/HB/CBM/HBM

Model No.	Outer dimensions			LM block dimensions											Pilot hole for side nipple			
	Height M	Width W	Length <sup>1</sup> L	B	C	H	L <sub>1</sub>	t	T	T <sub>1</sub>	K	N	E	Grease nipple	e <sub>0</sub>	f <sub>0</sub>	D <sub>0</sub> <sup>2</sup>	H <sub>3</sub>
HSR 20CB HSR 20CBM	30	63	74	53	40	6	50.8	10	9.5	10	26	5	12	B-M6F	3.1	3.4	3	4
HSR 20HB HSR 20HBM	30	63	90	53	40	6	66.8	10	9.5	10	26	5	12	B-M6F	3.1	3.4	3	4
HSR 25CB HSR 25CBM	36	70	83.1	57	45	7	59.5	16	11	10	30.5	6	12	B-M6F	3.5	4	3	5.5
HSR 25HB HSR 25HBM	36	70	102.2	57	45	7	78.6	16	11	10	30.5	6	12	B-M6F	3.5	4	3	5.5
HSR 30CB HSR 30CBM	42	90	98	72	52	9	70.4	18	9	10	35	7	12	B-M6F	5.2	6.2	5.2	7
HSR 30HB HSR 30HBM	42	90	120.6	72	52	9	93	18	9	10	35	7	12	B-M6F	5.2	6.2	5.2	7
HSR 35CB HSR 35CBM	48	100	109.4	82	62	9	80.4	21	12	13	40.5	8	12	B-M6F	5.5	5.6	5.2	7.5
HSR 35HB HSR 35HBM	48	100	134.8	82	62	9	105.8	21	12	13	40.5	8	12	B-M6F	5.5	5.6	5.2	7.5
HSR 45CB HSR 45HB	60	120	138.9 170.7	100	80	11	98 129.8	25	13	15	50	10	16	B-PT1/8	6.1	6.6	5.2	10
HSR 55CB HSR 55HB	70	140	162.9 201	116	95	14	118 156.1	29	13.5	17	57	11	16	B-PT1/8	5.6	7.7	5.2	13
HSR 65XCB HSR 65XHB	90	170	190.5 250	142	110	16	138.5 198	37	21.5	23	76	19	16	B-PT1/8	6.8	14.6	5.2	14
HSR 85CB HSR 85HB	110	215	245.6 303	185	140	18	178.6 236	55	28	30	94	23	16	B-PT1/8	—	—	—	16

### Model number coding

**HSR35 CB 2 QZ ZZHH C0 M +1400L P T M - II**

Model number

Type of LM block

With QZ Lubricator

Contamination protection accessory symbol

Stainless steel LM block

LM rail length (in mm)

Stainless steel LM rail

No. of LM blocks used on the same rail

Radial clearance symbol  
Normal (No symbol)  
Light preload (C1)  
Medium preload (C0)

Accuracy symbol  
Normal grade (No Symbol)  
High accuracy grade (H)  
Precision grade (P)  
Super precision grade (SP)  
Ultra precision grade (UP)

Symbol for LM rail jointed use

Symbol for No. of rails used on the same plane

Notes: This model number indicates that a single-rail unit constitutes one set (i.e., required number of sets when 2 rails are used in parallel is 2 at a minimum).

Grease nipples are not installed when there is a QZ Lubricator. Contact THK if you want to use a grease nipple for a model with a QZ. See [A1-547](#) for contamination protection accessories, see [A1-74](#) for radial clearance symbol. See [A1-79](#) for accuracy symbol. See [A1-13](#) for symbol for number of rails used on the same plane.

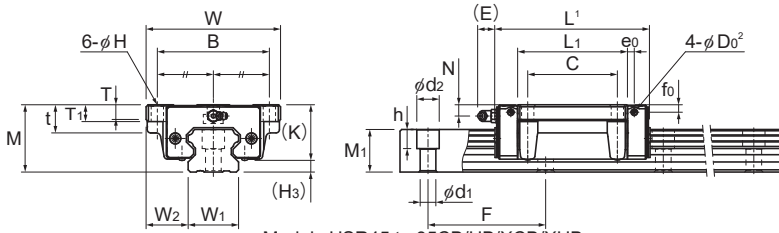

Models HSR45 to 85CB/HB/XCB/XHB

Unit: mm

LM rail dimensions						Basic load rating		Static permissible moment $\text{kN}\cdot\text{m}^{-1}$					Mass	
Width $W_1$ $\pm 0.05$	$W_2$	Height $M_1$	Pitch $F$	$d_1 \times d_2 \times h$	Length <sup>3</sup> Max	C kN	$C_0$ kN	$M_a$		$M_b$		$M_c$	LM block kg	LM rail kg/m
								1 block	2 blocks	1 block	2 blocks	1 block		
20	21.5	18	60	$6 \times 9.5 \times 8.5$	3000 (1480)	19.8	27.4	0.218	1.2	0.218	1.2	0.235	0.35	2.3
20	21.5	18	60	$6 \times 9.5 \times 8.5$	3000 (1480)	23.9	35.8	0.363	1.87	0.363	1.87	0.307	0.47	2.3
23	23.5	22	60	$7 \times 11 \times 9$	3000 (2020)	27.6	36.4	0.324	1.8	0.324	1.8	0.366	0.59	3.3
23	23.5	22	60	$7 \times 11 \times 9$	3000 (2020)	35.2	51.6	0.627	3.04	0.627	3.04	0.518	0.75	3.3
28	31	26	80	$9 \times 14 \times 12$	3000 (2520)	40.5	53.7	0.599	3.1	0.599	3.1	0.652	1.1	4.8
28	31	26	80	$9 \times 14 \times 12$	3000 (2520)	48.9	70.2	0.995	4.89	0.995	4.89	0.852	1.3	4.8
34	33	29	80	$9 \times 14 \times 12$	3000 (2520)	53.9	70.2	0.895	4.51	0.895	4.51	1.05	1.6	6.6
34	33	29	80	$9 \times 14 \times 12$	3000 (2520)	65	91.7	1.49	7.13	1.49	7.13	1.37	2	6.6
45	37.5	38	105	$14 \times 20 \times 17$	3090	82.2 100	101 135	1.5 2.59	8.37 13.4	1.5 2.59	8.37 13.4	1.94 2.6	2.8 3.3	11
53	43.5	44	120	$16 \times 23 \times 20$	3060	121 148	146 194	2.6 4.46	14.1 22.7	2.6 4.46	14.1 22.7	3.43 4.56	4.5 5.7	15.1
63	53.5	53	150	$18 \times 26 \times 22$	3000	195 249	228 323	5.08 9.81	25 45.6	5.08 9.81	25 45.6	6.2 8.79	8.5 10.7	22.5
85	65	65	180	$24 \times 35 \times 28$	3000	304 367	355 464	10.2 16.9	51.2 81	10.2 16.9	51.2 81	12.8 16.7	17 23	35.2

<sup>1</sup> Length L shown in the table is the length with the contamination protection accessories, code UU or SS.  
If other contamination protection accessories or lubricant equipment are installed, the total block length will increase. (See **A1-521** or **A1-543**)

<sup>2</sup>  $D_0$  are the pilot holes for when a grease nipple is desired for a product with LaCS or a QZ Lubricator.  
Pilot holes are not drilled through for models other than those stated above.  
For grease nipple mount machining, contact THK.

<sup>3</sup> The maximum length indicates the standard maximum length of an LM rail. (See **A1-208**.)

<sup>4</sup> Static permissible moment 1 block: the static permissible moment with one LM block  
2 blocks: the static permissible moment with two LM blocks in close contact with each other

Notes: The M in the model number symbol indicates that the LM block, LM rail and balls are made of stainless steel.  
The stainless steel provides excellent corrosion and environmental resistance.

# Models HSR85A, HSR85LA, HSR85B, and HSR85LB

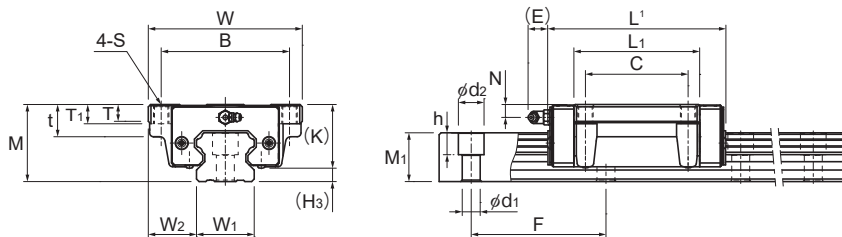

Models HSR85A/LA

Model No.	Outer dimensions			LM block dimensions													Grease nipple	H <sub>3</sub>
	Height	Width	Length <sup>1</sup>	B	C	H	S	L <sub>1</sub>	t	T	T <sub>1</sub>	K	N	E				
	M	W	L															
HSR 85A HSR 85LA	110	215	245.6 303	185	140	—	M20	178.6 236	55	28	30	94	23	16	B-PT1/8	16		
HSR 85B HSR 85LB	110	215	245.6 303	185	140	18	—	178.6 236	55	28	30	94	23	16	B-PT1/8	16		

## Model number coding

**HSR85 A 2 UU C0 +2250L H T -II**

Model number

Type of LM block

Contamination protection accessory symbol

LM rail length (in mm)

Symbol for LM rail jointed use

Symbol for No. of rails used on the same plane

No. of LM blocks used on the same rail

Radial clearance symbol  
Normal (No symbol)  
Light preload (C1)  
Medium preload (C0)

Accuracy symbol  
Normal grade (No Symbol)/High accuracy grade (H)  
Precision grade (P)/Super precision grade (SP)  
Ultra precision grade (UP)

Notes: This model number indicates that a single-rail unit constitutes one set (i.e., required number of sets when 2 rails are used in parallel is 2 at a minimum).

See [A1-547](#) for contamination protection accessories, see [A1-74](#) for radial clearance symbol. See [A1-79](#) for accuracy symbol. See [A1-13](#) for symbol for number of rails used on the same plane.

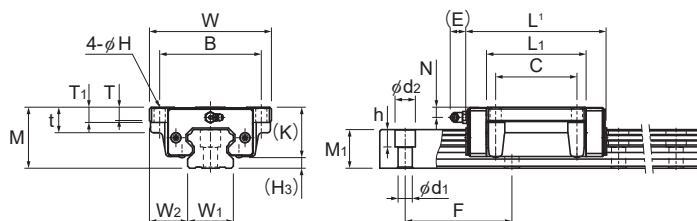

Models HSR85B/LB

Unit: mm

LM rail dimensions						Basic load rating		Static permissible moment $\text{kN}\cdot\text{m}^3$					Mass	
Width $W_1$ $\pm 0.05$	Height $M_1$	Pitch $F$	Length <sup>2</sup> Max	$d_1 \times d_2 \times h$	C kN	$C_0$ kN	$M_A$ 		$M_B$ 		$M_C$ 	LM block kg	LM rail kg/m	
							1 block	2 blocks	1 block	2 blocks	1 block			
85	65	180	3000	$24 \times 35 \times 28$	304 367	355 464	10.2 16.9	51.2 81	10.2 16.9	51.2 81	12.8 16.7	17 23	35.2	
85	65	180	3000	$24 \times 35 \times 28$	304 367	355 464	10.2 16.9	51.2 81	10.2 16.9	51.2 81	12.8 16.7	17 23	35.2	

<sup>1</sup> Length L shown in the table is the length with the contamination protection accessories, code UU or SS.  
If other contamination protection accessories or lubricant equipment are installed, the total block length will increase. (See [A1-521](#) or [A1-543](#))

<sup>2</sup> The maximum length indicates the standard maximum length of an LM rail. (See [A1-208](#).)

<sup>3</sup> Static permissible moment    1 block: the static permissible moment with one LM block  
  2 blocks: the static permissible moment with two LM blocks in close contact with each other

## Models HSR-HA, HSR-HB, and HSR-HR

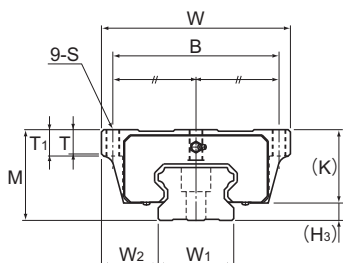

Models HSR100 to 150HA

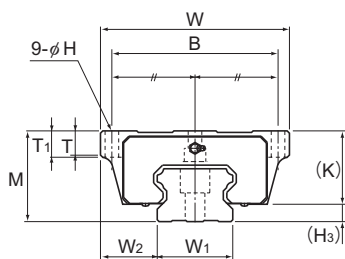

Models HSR100 to 150HB

Model No.	Outer dimensions			LM block dimensions										Grease nipple	H <sub>3</sub>
	Height	Width	Length <sup>1</sup>	B	C	H	S × ℓ	L <sub>i</sub>	T	T <sub>1</sub>	K	N	E		
	M	W	L												
HSR 100HA HSR 100HB HSR 100HR	120	250 250 200	334	220 220 130	200	20 — —	M18 through — M18 × 27	261	32 32 33	35 35 —	100	23	16	B-PT1/4	20
HSR 120HA HSR 120HB HSR 120HR	130	290 290 220	365	250 250 146	210	22 — —	M20 through — M20 × 30	287	34 34 33.7	38 38 —	110	26.5	16	B-PT1/4	20
HSR 150HA HSR 150HB HSR 150HR	145	350 350 266	396	300 300 180	230	26 — —	M24 through — M24 × 35	314	36 36 33	40 40 —	123	29	16	B-PT1/4	22

### Model number coding

## HSR150 HR 2 UU C1 +2350L H T - II

Model number

Type of LM block

Contamination protection accessory symbol

LM rail length (in mm)

Symbol for LM rail jointed use

Symbol for No. of rails used on the same plane

No. of LM blocks used on the same rail

Radial clearance symbol  
Normal (No symbol)  
Light preload (C1)  
Medium preload (C0)

Accuracy symbol  
Normal grade (No Symbol)/High accuracy grade (H)  
Precision grade (P)/Super precision grade (SP)  
Ultra precision grade (UP)

Notes: This model number indicates that a single-rail unit constitutes one set (i.e., required number of sets when 2 rails are used in parallel is 2 at a minimum).

See [A1-547](#) for contamination protection accessories, see [A1-74](#) for radial clearance symbol. See [A1-79](#) for accuracy symbol. See [A1-13](#) for symbol for number of rails used on the same plane.

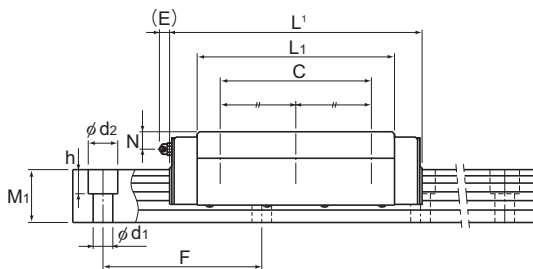
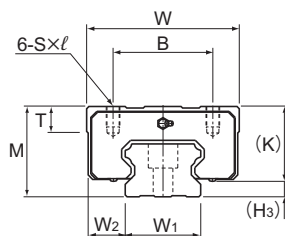

Models HSR100 to 150HR

Unit: mm

	LM rail dimensions					Basic load rating		Static permissible moment kN·m <sup>3</sup>					Mass	
	Width	Height	Pitch	Length <sup>2</sup>	C	C <sub>0</sub>	M <sub>A</sub>		M <sub>B</sub>		M <sub>C</sub>	LM block	LM rail	
	W <sub>1</sub> ±0.05						M <sub>1</sub>	F	d <sub>1</sub> × d <sub>2</sub> × h	Max	kN	kN	1 block	2 blocks
100	75 75 50	70	210	26 × 39 × 32	3000	441	540	20.7	105	20.7	105	24.1	32	49
114	88 88 53	75	230	33 × 48 × 43	3000	540	653	27.5	138	27.5	138	33.3	43	61
144	103 103 61	85	250	39 × 58 × 46	3000	518	728	33.6	167	33.6	167	45.2	62	87

<sup>1</sup> Length L shown in the table is the length with the contamination protection accessories, code UU or SS.

If other contamination protection accessories or lubricant equipment are installed, the total block length will increase. (See [A1-521](#) or [A1-543](#))

<sup>2</sup> The maximum length indicates the standard maximum length of an LM rail. (See [A1-208](#).)

<sup>3</sup> Static permissible moment    1 block: the static permissible moment with one LM block  
    2 blocks: the static permissible moment with two LM blocks in close contact with each other

## Standard Lengths and Maximum Lengths of LM Rails

Table 1 shows the standard lengths and the maximum lengths of model HSR variations. If the maximum length of the desired LM rail exceeds these values, jointed rails will be used. Contact THK for details.

For special rail lengths, it is recommended to use a value corresponding to the G and g dimensions from the table. As the G and g dimensions increase, this portion becomes less stable, and the accuracy performance is severely impacted.

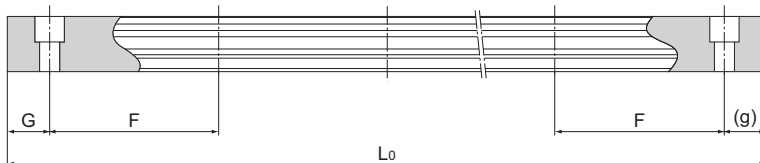

Table 1: Standard Lengths and Maximum Lengths of LM Rails for Model HSR

Unit: mm

Model No.	HSR 8	HSR 10	HSR 12	HSR 15	HSR 20	HSR 25	HSR 30	HSR 35	HSR 45	HSR 55	HSR 65	HSR 85	HSR 100	HSR 120	HSR 150
LM rail standard lengths ( $L_0$ )	35	45	70	160	160	220	280	280	570	780	1270	1530	1340	1470	1600
	55	70	110	220	220	280	360	360	675	900	1570	1890	1760	1930	2100
	75	95	150	280	280	340	440	440	780	1020	2020	2250	2180	2390	2350
	95	120	190	340	340	400	520	520	885	1140	2620	2610	2600		
	115	145	230	400	400	460	600	600	990	1260					
	135	170	270	460	460	520	680	680	1095	1380					
	155	195	310	520	520	580	760	760	1200	1500					
	175	220	350	580	580	640	840	840	1305	1620					
	195	245	390	640	640	700	920	920	1410	1740					
	215	270	430	700	700	760	1000	1000	1515	1860					
	235	295	470	760	760	820	1080	1080	1620	1980					
	255	320	510	820	820	940	1160	1160	1725	2100					
	275	345	550	940	940	1000	1240	1240	1830	2220					
		370	590	1000	1000	1060	1320	1320	1935	2340					
		395	630	1060	1060	1120	1400	1400	2040	2460					
		420	670	1120	1120	1180	1480	1480	2145	2580					
		445		1180	1180	1240	1560	1560	2250	2700					
		470		1240	1240	1300	1640	1640	2355	2820					
				1360	1360	1360	1720	1720	2460	2940					
				1480	1480	1420	1800	1800	2565	3060					
			1600	1600	1480	1880	1880	2670							
					1720	1540	1960	1960	2775						
					1840	1600	2040	2040	2880						
					1960	1720	2200	2200	2985						
					2080	1840	2360	2360	3090						
					2200	1960	2520	2520							
						2080	2680	2680							
						2200	2840	2840							
						2320	3000	3000							
						2440									
Standard pitch F	20	25	40	60	60	60	80	80	105	120	150	180	210	230	250
G, g	7.5	10	15	20	20	20	20	20	22.5	30	35	45	40	45	50
Max length	(975)	(995)	(1240)	<sup>3000</sup> <sub>(1240)</sub>	<sup>3000</sup> <sub>(1480)</sub>	<sup>3000</sup> <sub>(2020)</sub>	<sup>3000</sup> <sub>(2520)</sub>	<sup>3000</sup> <sub>(2520)</sub>	3090	3060	3000	3000	3000	3000	3000

Notes: The maximum length varies with accuracy grades. Contact THK for details.

If jointed rails are not allowed and a greater length than the maximum values above is required, contact THK. The figures in the parentheses indicate the maximum lengths of stainless steel made models.

## Tapped-Hole Type LM Rail

HSR model rails also include a type where the LM rail is tapped from the bottom. This type is useful when mounting from the bottom of the base and when increased contamination protection is desired.

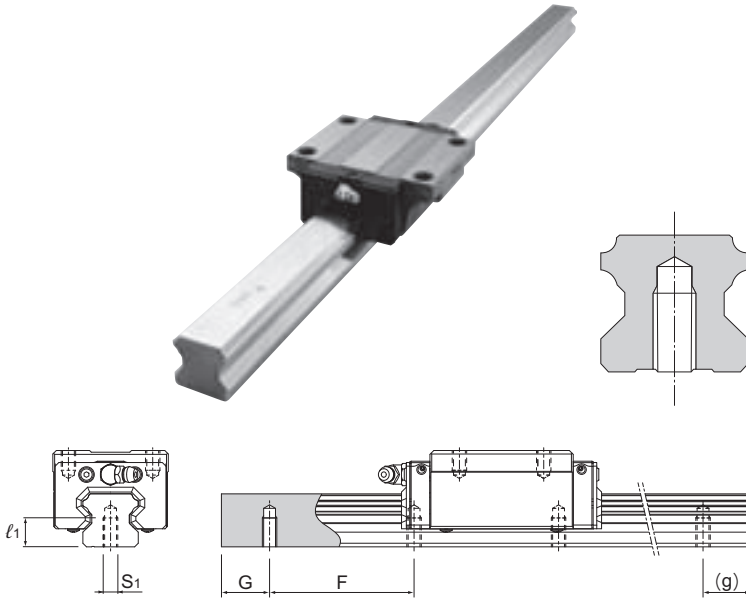

- (1) A tapped-hole LM rail type is available only for Precision grade or lower grades.
- (2) A tapped-hole LM rail type is also available for models HSR-YR and HSR-XYR.
- (3) For standard pitches of the taps and the G and g dimensions, see Table 1 on **A1-208**.

Table 2: Dimensions of the LM Rail Tap

Unit: mm

Model No.	$S_1$	Effective tap depth $\ell_1$
HSR 15	M5	8
HSR 20	M6	10
HSR 25	M6	12
HSR 30	M8	15
HSR 35	M8	17
HSR 45	M12	24
HSR 55	M14	24
HSR 65	M20	30

### Model number coding

**HSR30R2UU+1000LH K**

**T**  
Symbol for  
tapped-hole LM rail type

## Preventing the LM Block from Falling off of the LM Rail

In miniature Model HSR, the balls fall out if the LM block comes off the LM rail.

For this reason, LM Guide assemblies are delivered with a part which prevents the LM block from coming off the rail. If you remove this part when using the product, please take precautions to avoid overrunning the blocks off of the rail.

## Lubrication Hole

### Lubrication Hole for Model HSR

The Model HSR LM block can be lubricated from the side or top surface. In order to prevent foreign material from entering the LM block, lubrication holes are not through holes in blocks with regular specifications. Contact THK if these will be used.

In addition, contact THK if you will use an upper surface greasing hole with a Model HSR-R/XR/LR/XLR/YR/XYR, as a lubrication adapter is required.

The lubricant may not reach the raceway if the LM Guide is not installed in a horizontal orientation.

Be sure to let THK know the mounting orientation and the position where the grease nipple or plumbing fixture will be attached to each LM block.

See **A1-12** for the mounting orientation and **A24-2** for lubrication.

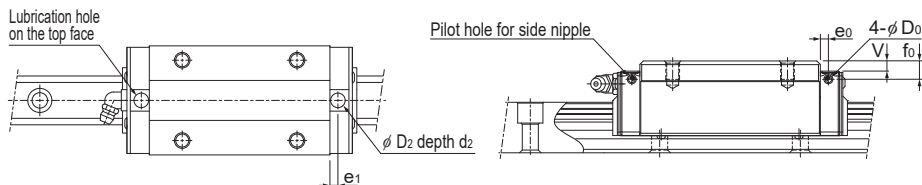

Notes: Upper surface lubrication is oil lubrication only. Contact THK if you are considering using the lubrication hole on the top face for grease lubrication.

Unit: mm

Model No.		Pilot hole for side nipple			Applicable nipple	Lubrication hole on the top face				
		e <sub>0</sub>	f <sub>0</sub>	D <sub>0</sub>		D <sub>2</sub>	(O-ring)	V	e <sub>1</sub>	d <sub>2</sub>
HSR	15C	3.2	3.9	3	PB107	5.1	SS4	0.3	3.2	0.65
	15LC									
	15CA									
	15HA									
	15CB									
	15HB									
	15R	3.2	7.9	3		4.3				
	15LR									
	15YR	3.1	3.4	3		6	SS5	0.2	4.3	0.6
	20C									
	20LC									
	20CA									
	20HA									
	20CB									
20HB										
20R	3.1				3.4					
20LR										
20YR										
20YR										

Model No.		Pilot hole for side nipple			Applicable nipple	Lubrication hole on the top face																								
		$e_0$	$f_0$	$D_0$		$D_2$	(O-ring)	V	$e_1$	$d_2$																				
HSR	25C 25LC 25CA 25HA 25CB 25HB 25R 25LR 25YR	3.5	4	3	PB107	6.2	P3	0.4	3.9	1																				
	3.5	8	3	4.4																										
	30C 30LC 30CA 30HA 30CB 30HB 30R 30LR 30YR	5.2	6.2	5.2	M6F	6.2	P3	0.4	5.2	1																				
	5.2	9.2	5.2	3.4																										
	35C 35LC 35CA 35HA 35CB 35HB 35R 35LR 35YR	5.5	5.6	5.2				M6F			6.2	P3	0.4	5.5	1															
	5.5	12.6	5.2	7.4																										
	45C 45LC 45CA 45HA 45CB 45HB 45R 45LR 45YR	6.1	6.6	5.2									M6F			10.2	P7	0.4	8.2	1										
	6.1	16.6	5.2	10.4																										
	55C 55LC 55CA 55HA 55CB 55HB 55R 55LR 55YR	5.6	7.7	5.2														M6F			10.2	P7	0.4	9.1	1					
	5.6	17.7	5.2	10.4																										
	65XC 65XLC 65XCA 65XHA 65XCB 65XHB 65XR 65XLR 65YR	6.8	14.6	5.2																			M6F			10.2	P7	5.9	9.5	1
	6.8	14.6	5.2	5.9																										

### Semi-Standard Lubrication Hole for Model HSR

For model HSR, a semi-standard lubrication hole is available. Specify the appropriate model number according to the application.

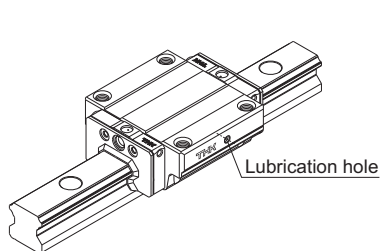

Type with a Lubrication Hole Drilled on the Side Surface

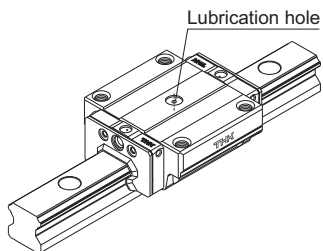

Type with a Lubrication Hole Drilled on the Top Face

