



Economy Series Electric Actuator

# VLAST/VLACT



An electric alternative to pneumatics

Electric Actuator

# VLAST/VLACT

Switch from pneumatics to electricity with a simple, energy-efficient, high-performance actuator

## VLAST

An all-in-one electric actuator combining an LM Guide, ball screw, and housing

The built-in Linear Motion (LM) Guide eliminates the need for an external guide element.

In comparison with air cylinders, this product also offers higher precision for multi-point positioning when moving between two or more points.

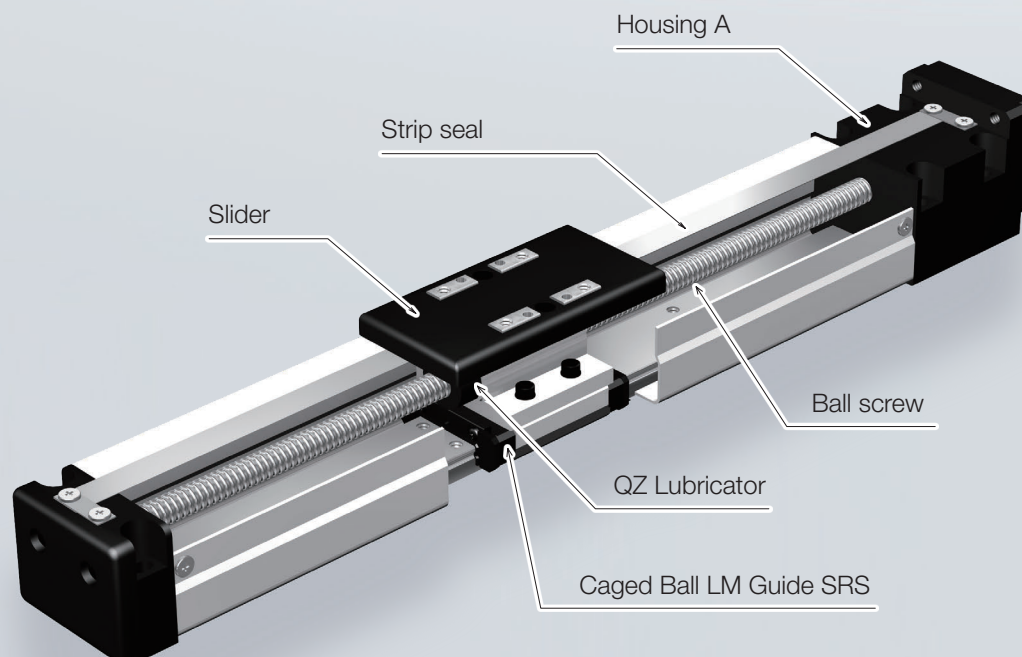

Maximum speed  
**1000** mm/s

Positioning repeatability  
**±0.02** mm

# VLACT

An electric cylinder with an internal ball screw

In comparison with air cylinders, this product offers higher precision for multi-point positioning when moving between two or more points thanks to using a ball screw as the drive element.

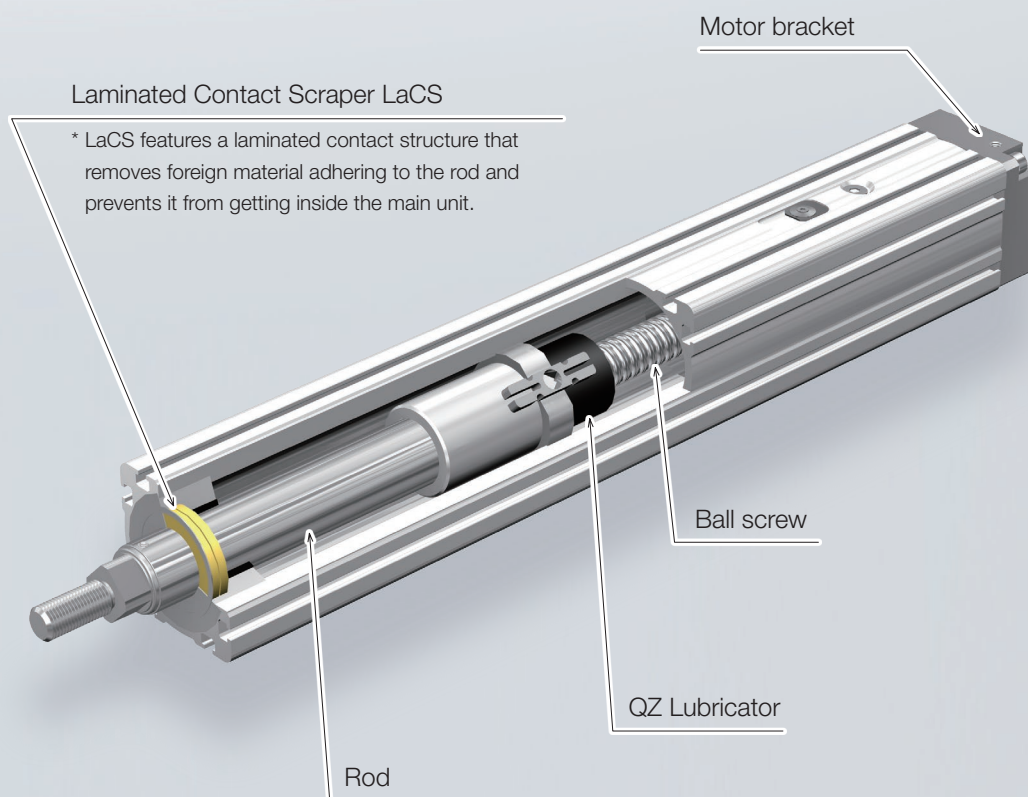

Maximum thrust  
**895 N**

Positioning repeatability  
**±0.02 mm**

# A quiet, energy-efficient, eco-friendly electric actuator

## THK Technology 1

### Cost-effective, simple structure

With an LM Guide directly forming the base, this simple design reduces the number of components.

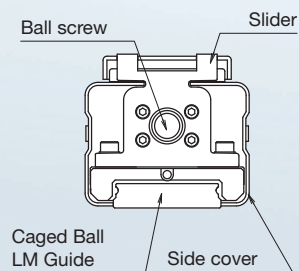

\* VLAST only.

## THK Technology 2

### Lightweight and compact

This series adopts the Caged Ball LM Guide SRS, which has a compact rail cross-section height that allows for lightweight, space-saving designs.

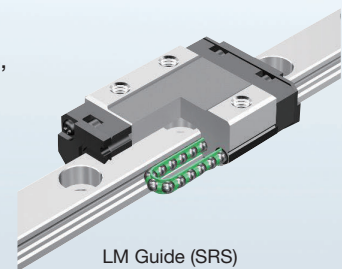

\* VLAST only.

## THK Technology 3

### Motor compatibility for various applications

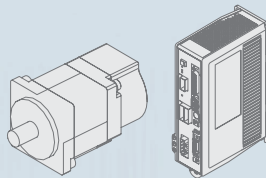

Various motors and drivers

The VLA is designed to be compatible with various types of motors. You can employ the type of control you are used to.

Compatible motor manufacturers:  
Yaskawa Electric/Mitsubishi Electric/Tamagawa Seiki/Keyence/SANYO Electric/OMRON

## THK Technology 4

### Long-term maintenance-free operation

Long-term maintenance-free operation has been achieved by the adoption of the Caged Ball LM Guide SRS\* and the QZ Lubricator, which supplies the optimal amount of lubricant to the ball screw.

\* VLAST only.

The QZ Lubricator feeds the right amount of lubricant to the ball screw shaft raceway.

This allows an oil film to be constantly formed between the balls and the raceway, which improves the lubricity and significantly extends the maintenance interval.

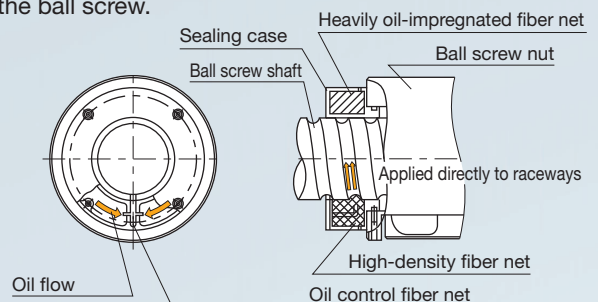

## THK Technology 5

### Service life calculation

The service life of the LM Guide and ball screw can be calculated based on the usage conditions. Contact THK for details.

# Using this product in place of pneumatic devices enables multi-point positioning and speed adjustments. It is perfect for moving lightweight objects, too.



## General industry Automatic inkjet printers

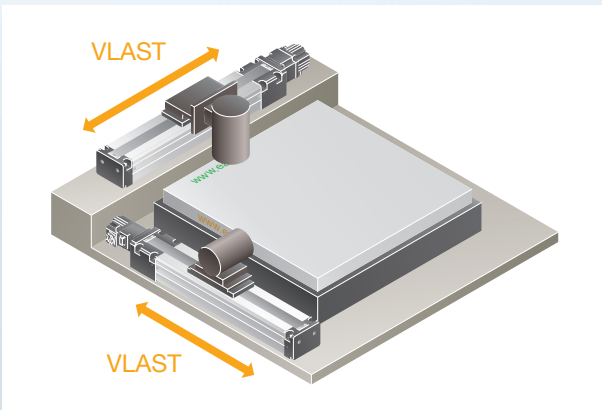

The VLAST is used in the parts that move the inkjet heads. The device can be constructed at a low cost.

Models used

X axis: VLAST  
Y axis: VLAST



## General industry Oil brushing machines

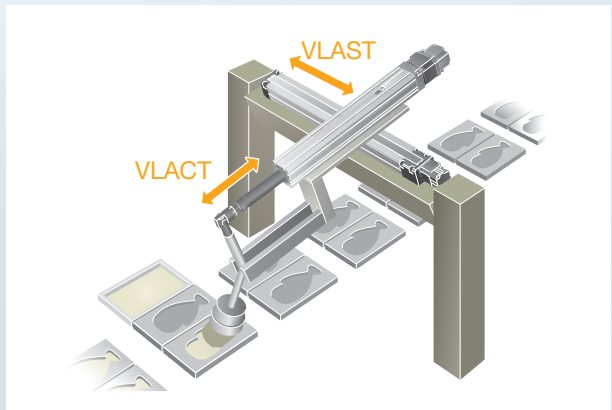

The VLACT is used to drive the oil brush, and the VLAST is used for the part that moves the brush. The VLAST/VLACT were adopted for their ease of operation. In addition, food-grade grease was used for the mechanical portions so they could be used on food equipment.

Models used

X axis: VLAST  
Y axis: VLACT

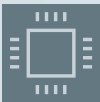

## Electronic component industry Visual inspection devices

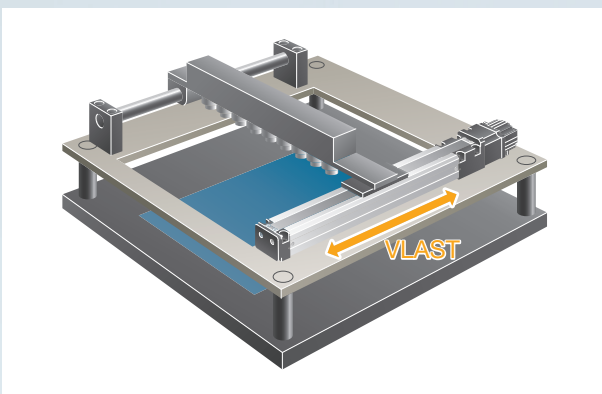

The VLAST is used in the part that moves the camera. The cost of this device was successfully reduced by combining a linear bush with the VLAST, which itself achieves accurate positioning at a low cost.

Models used

X axis: VLAST



## Machine tool industry Loaders for automatic lathes

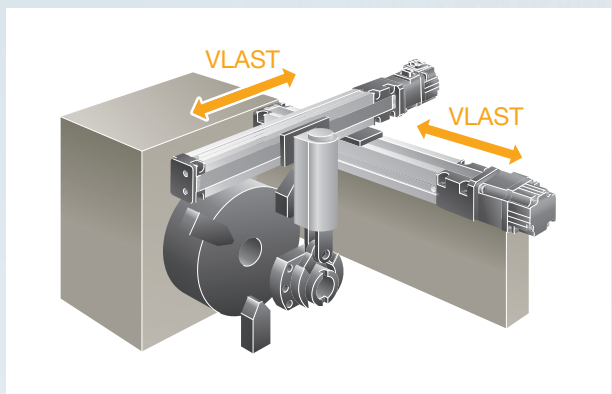

The VLAST is used in the parts that move the workpiece. Even though the VLAST is installed close enough to the machining process that cutting chips adhere to it, no foreign material will get inside thanks to its fully covered structure.

Models used

X axis: VLAST  
Y axis: VLAST

## Series Overview

Model	Ball screw lead (mm)	Stroke (mm)	Estimated motor capacity (W)	Maximum load capacity <sup>1</sup> (kg)		
				Horizontal	Wall-mounted	Vertical
VLAST45	6	50 to 500	50	11.5	11	7
	12			11.5	10.5	5.5
VLAST60	6	50 to 700	50	29.5	23	11.5
	12			12	12	5.5
	6		100	29.5	23	11.5
	12			25	21	11
VLACT35	6	50 to 150	50	8	—	8
	12			8	—	6
VLACT45	6	50 to 200	50	19	—	11.5
	12			13.5	—	6
VLACT55	6	50 to 300	100	56	—	23
	12			25	—	11.5

<sup>1</sup> Maximum load capacity refers to the mass at the below speed and acceleration/deceleration.

Speed: The rated rotational speed of the motor (3,000 min<sup>-1</sup>).

Acceleration/deceleration: 0.15 G for a 6 mm lead, 0.3 G for a 12 mm lead.

<sup>2</sup> The maximum speed is restricted by the permissible speed of the actuator.

## Model Number Coding

Model ①	Ball screw lead ②	Stroke ③	With or without motor ④	Sensor ⑤	Option ⑥
VLAST60	06	0150	0	0	N
VLAST45	06: 6 mm	0050: 50 mm to	0: Without motor	0: Without	N: None
VLAST60	12: 12 mm	0700: 700 mm	1: With motor (THK will purchase and mount the motor you specify)	1	A: Bracket base
VLACT35				6	B: Flange
VLACT45				7	
VLACT55				B	
				E	
				H	
				L	
				J	
				M	

If "0" is selected:

No coupling will be attached to the VLAST. Please specify if a coupling is required when ordering.

\* With standard specifications, the VLACT will be shipped with a coupling mounted on the body.

If "1" is selected:

The designated motor will be mounted. Please specify the motor cable direction separately. Please select the coupling, driver, and controller yourself.

This product is compatible with motors from various manufacturers. Contact THK for details.

VLAST45 and VLAST60 are not available with options "A" or "B."

	Maximum speed at each stroke <sup>2</sup> (mm/s)														Page
	Stroke (mm)														
	50	100	150	200	250	300	350	400	450	500	550	600	700		
	500							420	340						p. 7
	1000							840	680						
	500					400					340	250		p. 11	
	1000					800					680	500			
	500					400					340	250			
	1000					800					680	500			
	300													p. 15	
	600														
	300													p. 17	
	600														
	300				235									p. 19	
	600				470										

# VLAST45

Servo motor <b>50 W</b>	Type <b>Slider</b>	Motor Direct coupling	Body width <b>45 mm</b>	Body height <b>45 mm</b>	Max. stroke <b>500 mm</b>	Max. speed <b>1000 mm/s</b>
----------------------------	-----------------------	-----------------------------	-------------------------------	--------------------------------	---------------------------------	-----------------------------------

## Model Configuration

Model	Ball screw lead	Stroke	With or without motor	Sensor	Option
①	②	③	④	⑤	⑥
VLAST45	06	0150	0	0	N
VLAST45	06: 6 mm 12: 12 mm	0050: 50 mm to 0500: 500 mm	0: Without motor 1: With motor (THK will purchase and mount the motor you specify)	0: Without 1 6 7 B E H L J M	N: None

If "0" is selected:  
No coupling will be attached. Please specify if a coupling is required when ordering.  
If "1" is selected:  
The designated motor will be mounted. Please specify the motor cable direction separately.  
Please select the coupling, driver, and controller yourself.

## Selection Information

### Basic Specifications

LM Guide unit	Basic dynamic load rating C (N)	5480		
	Basic static load rating C <sub>0</sub> (N)	5300		
	Radial clearance (mm)	-0.002 to +0.002		
	Geometric moment of inertia <sup>1,2,3</sup>	I <sub>x</sub> (mm <sup>4</sup> )	1.21 × 10 <sup>3</sup>	
		I <sub>y</sub> (mm <sup>4</sup> )	9.42 × 10 <sup>3</sup>	
	Mass (kg/m)	1.01		
Ball screw	Ball screw lead (mm)	6	12	
	Basic dynamic load rating C <sub>a</sub> (N)	1950	900	
	Basic static load rating C <sub>0a</sub> (N)	3510	1610	
	Screw shaft diameter (mm)	φ8		
	Thread minor diameter (mm)	φ6.8		
	Ball center-to-center diameter (mm)	φ8.4		
Bearing (fixed side)	Axial direction	Basic dynamic load rating C <sub>a</sub> (N)	1400	
		Static permissible load P <sub>0a</sub> (N)	630	
	Positioning repeatability (mm)	±0.02		
	Backlash (mm)	0.1		
	Permissible input torque (N·m)	0.66	0.8	
	Static permissible moment <sup>5</sup> (N·m)	M <sub>A</sub> : 12, M <sub>B</sub> : 12, M <sub>C</sub> : 24		
	Standard grease	THK AFF Grease		

<sup>1</sup> This is the geometric moment of inertia for the LM Guide rail.

<sup>2</sup> I<sub>x</sub> is the geometric moment of inertia about the X axis.

<sup>3</sup> I<sub>y</sub> is the geometric moment of inertia about the Y axis.

<sup>4</sup> The permissible rotational speed may decrease as the stroke becomes longer.

<sup>5</sup> Static permissible moment is the maximum moment that can be permitted while the product is stationary.

#### Horizontal

Estimated motor capacity (W)		50	
Ball screw lead (mm)		6	12
Maximum load capacity <sup>6</sup> (kg)	Acceleration/deceleration	0.15 G	11.5
		0.3 G	11.5
		0.5 G	-

#### Wall-Mounted

Estimated motor capacity (W)		50	
Ball screw lead (mm)		6	12
Maximum load capacity <sup>6</sup> (kg)	Acceleration/deceleration	0.15 G	11
		0.3 G	11
		0.5 G	-

#### Vertical

Estimated motor capacity (W)		50	
Ball screw lead (mm)		6	12
Maximum load capacity <sup>6</sup> (kg)	Acceleration/deceleration	0.15 G	7
		0.3 G	7
		0.5 G	-

<sup>6</sup> Maximum load capacity refers to the mass at the below speed.

Speed: The rated rotational speed of the motor (3,000 min<sup>-1</sup>).

#### Geometric moment of inertia

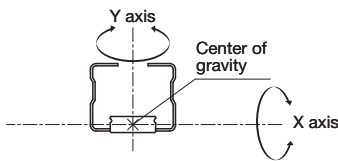

#### Static permissible moment

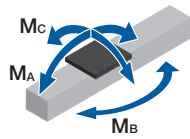

### Permissible Overhang Length<sup>7</sup>

#### Horizontal

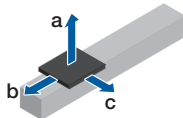

#### Wall-Mounted

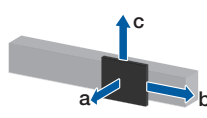

#### Vertical

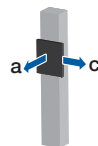

50 W	Ball screw lead (mm)	Load mass (kg)	a (mm)	b (mm)	c (mm)
Direct coupling	6	2.5	240	160	240
		5.5	240	80	160
		11.5	110	30	70
	12	2.5	240	160	240
		5.5	240	80	120
		11.5	110	30	50

50 W	Ball screw lead (mm)	Load mass (kg)	a (mm)	b (mm)	c (mm)
Direct coupling	6	2.5	240	160	240
		5.5	120	70	240
		11	40	20	120
	12	2.5	240	160	240
		5	130	70	240
		10	40	20	130

50 W	Ball screw lead (mm)	Load mass (kg)	a (mm)	c (mm)
Direct coupling	6	1.5	210	200
		3.5	70	80
		7	20	40
	12	1	240	240
		2.5	110	120
		5.5	30	50

<sup>7</sup> This is the value with the service life of the LM Guide limited to 5,000 km. The calculation conditions are as follows.

Stroke: 275 mm / Acceleration/deceleration: 0.3 G / Speed: 300 m/s (for a 6 mm lead), 600 m/s (for a 12 mm lead) / Overhang direction: Loaded only in a single direction. Dimensions a, b, and c are from the center of the table's upper surface.

## Motor Selection Specifications

Stroke (mm)	LM Guide		Ball screw		Motor mounting part
	Moving part mass (kg)	Sliding resistance (N)	Lead (mm)	Shaft length (mm)	Shaft end diameter (mm)
50 to 500	0.1	6.6	6, 12	162 to 612	φ5h8

## Compatible Motors

The motors given in the table below can be mounted without an intermediate flange.

Motor type	Manufacturer	Series	Motor model	Motor rated output (W)	Flange size	Compatible coupling model		
						MIKI PULLEY CO., LTD.	Nabeya Bi-tech Kaisha (NBK)	
AC servo motor	Yaskawa Electric Corporation	Σ-V	SGMJV-A5	50	40 × 40	SFC-010DA2-5B-8B	XGT2-19C-5-8	
			SGMAV-A5					
		Σ-7	SGM7J-A5	50	40 × 40	SFC-010DA2-5B-8B	XGT2-19C-5-8	
			SGM7A-A5					
		Σ-X	SGMXJ-A5	50	40 × 40	SFC-010DA2-5B-8B	XGT2-19C-5-8	
			SGMXA-A5					
	Mitsubishi Electric Corporation	MELSERVO	J4	HG-KR053	50	40 × 40	SFC-010DA2-5B-8B	XGT2-19C-5-8
				HG-MR053				
			J5	HK-KT053W	50	40 × 40		
				JN	HF-KN053	50		
	Tamagawa Seiki Co., Ltd.	TBL-III	TS4602	50	40 × 40	SFC-010DA2-5B-8B	XGT2-19C-5-8	
			TSM3102	50	40 × 40			
	Keyence Corporation	SV	SV-M005	50	40 × 40	SFC-010DA2-5B-8B	XGT2-19C-5-8	
		SV2	SV2-M005	50	40 × 40			
	SANYO Electric	SANMOTION R	R2□A04005	50	40 × 40	SFC-010DA2-5B-8B	XGT2-19C-5-8	
	OMRON Corporation	OMNUC G5	R88M-K05030	50	40 × 40	SFC-010DA2-5B-8B	XGT2-19C-5-8	
FANUC CORPORATION	βis series	βis 0.2/5000	50	40 × 40	SFC-010DA2-5B-8B	XGT2-19C-5-8		

Note 1) Please select a straight motor shaft.

Note 2) Please select the motor options (brakes, encoders, etc.) offered by each manufacturer. See each manufacturer's catalog for details about the motors.

Note 3) If the motor is changed to a type not listed above, the actuator specifications may change. Each compatible motor was selected based on the actuator specifications, so it cannot be used in excess of the actuator's rated conditions.

Note 4) If the specifications without a motor are selected, no coupling will be attached.

Note 5) When selecting a coupling yourself, please keep the coupling length less than 20 mm. When selecting a coupling 20 mm or longer, please keep the outer diameter at 18.5 mm or less.

Note 6) If the maximum torque of the installed motor will exceed the permissible input torque (p. 7), please consider a safety measure to limit the torque.

# Dimensions

## Direct Motor Coupling

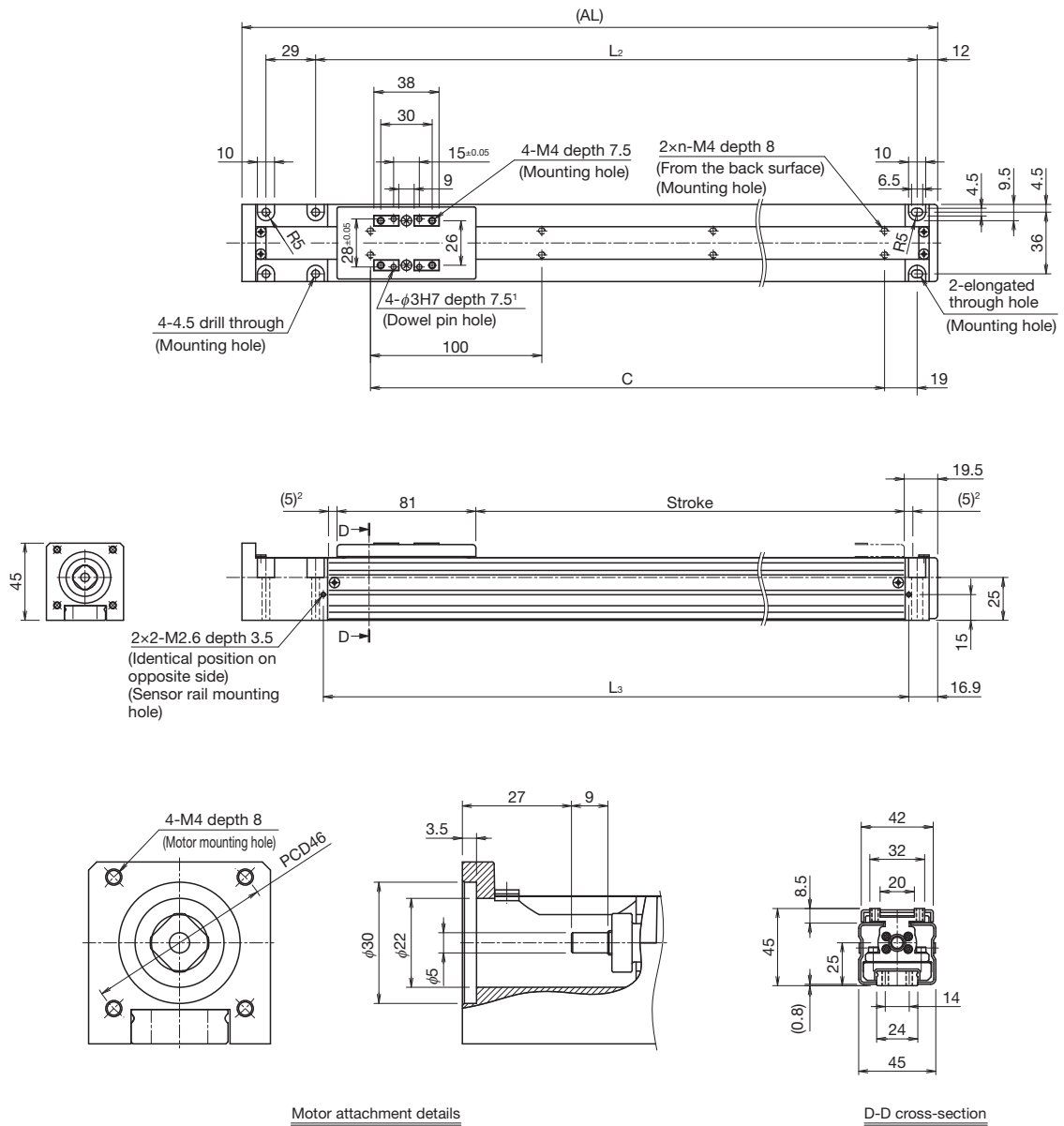

<sup>1</sup> These are through holes, so do not use a depth greater than 7.5 mm.  
<sup>2</sup> This is the stroke up to the mechanical stopper.

Stroke (mm) (Stroke between mechanical stoppers)		50 (60)	100 (110)	150 (160)	200 (210)	250 (260)	300 (310)	350 (360)	400 (410)	450 (460)	500 (510)	
Max. speed <sup>3</sup> (mm/s)	Ball screw lead: 6 mm										420	340
	Ball screw lead: 12 mm										840	680
Dimensions (mm)	AL	206	256	306	356	406	456	506	556	606	656	
	L <sub>2</sub>	151	201	251	301	351	401	451	501	551	601	
	L <sub>3</sub>	141.6	191.6	241.6	291.6	341.6	391.6	441.6	491.6	541.6	591.6	
	C	100	200	200	300	300	400	400	500	500	600	
No. of mounting holes	n	2	3	3	4	4	5	5	6	6	7	
Mass (kg)		0.9	1	1.1	1.2	1.3	1.4	1.5	1.6	1.7	1.9	

<sup>3</sup> The maximum speed is restricted by the permissible speed of the actuator.

# Options

## Sensors

Optional photo sensors and proximity sensors are available.

If you select the sensor option, all sensor-related components will be included with the main actuator unit. Please perform the installation yourself.

See the following precautions (Notes 1 to 3) before using.

Symbol	Details	Model No.	Accessories
0	No sensor	—	—
1	Sensor rail	—	Mounting screw, sensor rail (x1)
6	Photo sensors <sup>1</sup> (x3)	EE-SX674 (OMRON Corporation)	Mounting screw/nut, sensor rail (x1), mounting plates (x3), connectors (EE-1001 x3)
7	Sensors: N.O. contact <sup>2</sup> (x3) Sensors: N.C. contact <sup>3</sup> (x3)	APM-D3A1-001 (Azbil Corporation) APM-D3B1-003 (Azbil Corporation)	Mounting screw/nut, sensor rail (x1)
B	Sensors: N.O. contact <sup>2</sup> (x1) N.C. contact <sup>3</sup> (x2)	APM-D3A1-001 (Azbil Corporation) APM-D3B1-003 (Azbil Corporation)	Mounting screw/nut, sensor rail (x1)
H	Sensors: N.O. contact <sup>2</sup> (x3)	GX-F12A (Panasonic Industrial Devices SUNX Co., Ltd.)	Mounting screw/nut, sensor rail (x1)
L	Sensors: N.C. contact <sup>3</sup> (x3)	GX-F12B (Panasonic Industrial Devices SUNX Co., Ltd.)	Mounting screw/nut, sensor rail (x1)
J	Sensors: N.O. contact <sup>2</sup> (x1) N.C. contact <sup>3</sup> (x2)	GX-F12A (Panasonic Industrial Devices SUNX Co., Ltd.) GX-F12B (Panasonic Industrial Devices SUNX Co., Ltd.)	Mounting screw/nut, sensor rail (x1)
M	Sensors: N.O. contact <sup>2</sup> (x1) (PNP output) N.C. contact <sup>3</sup> (x2) (PNP output)	GX-F12A-P (Panasonic Industrial Devices SUNX Co., Ltd.) GX-F12B-P (Panasonic Industrial Devices SUNX Co., Ltd.)	Mounting screw/nut, sensor rail (x1)

<sup>1</sup> The photo sensors can be switched between ON when lit and ON when unlit.

<sup>2</sup> N.O. contact: Normally open contact

<sup>3</sup> N.C. contact: Normally closed contact

Note 1) Sensor dogs cannot be mounted to the main actuator unit, so please mount them to another object such as a workpiece or jig.

Note 2) If proximity sensors are close to one another, they may not function properly. If that happens, please prepare a type with a different frequency.

Note 3) It is possible to install sensors other than those listed above. Contact THK for details.

### Photo Sensor Installation Method

Sensor dogs are not included with the sensor option. Please reference the dimensional drawing below to design a sensor dog and then install the sensor.

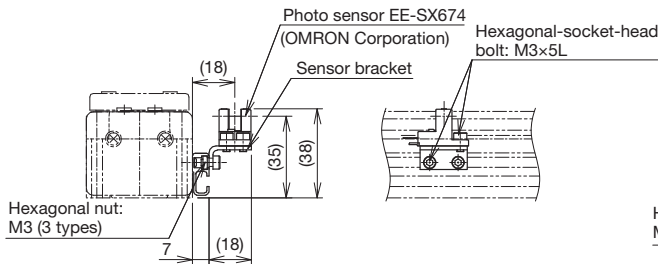

### Proximity Sensor Installation Method

Sensor dogs are not included with the sensor option. Please reference the dimensional drawing below to design a sensor dog and then install the sensor.

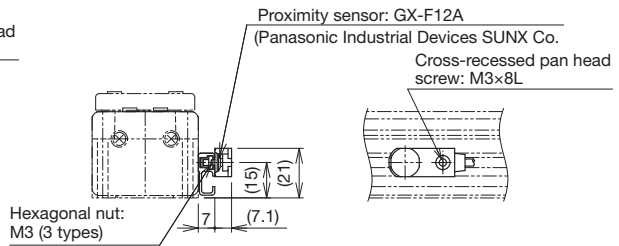

### Sensor Rail (Sold Separately)

Sensor Rail Model Number Coding

Model ①	Classification ②	Type ③	Stroke ④
TH	VSR	45	0100
TH	VSR	45: For VLAST45	0050: For 50 mm stroke to 0500: For 500 mm stroke

### Sensor Rail Dimensions

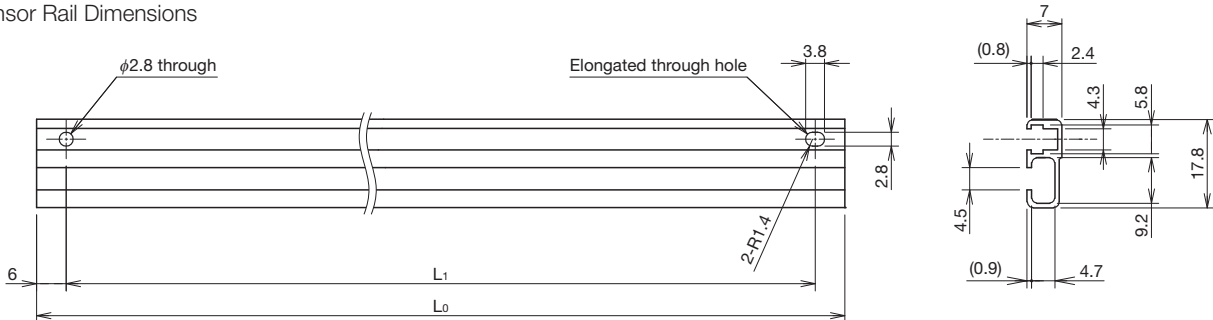

### TH-VSR-45

Stroke (mm)	50	100	150	200	250	300	350	400	450	500
Dimensions (mm)										
	L <sub>1</sub>	141.6	191.6	241.6	291.6	341.6	391.6	441.6	491.6	541.6
	L <sub>0</sub>	153.6	203.6	253.6	303.6	353.6	403.6	453.6	503.6	553.6

Note 4) Two No. 0 pan-head screws (M2.6x4L) are included for securing the sensor rail.

# VLAST60

Servo motor <b>50 W</b>	Servo motor <b>100 W</b>	Type <b>Slider</b>	Motor Direct coupling	Body width <b>64 mm</b>	Body height <b>60 mm</b>	Max. stroke <b>700 mm</b>	Max. speed <b>1000 mm/s</b>
----------------------------	-----------------------------	-----------------------	-----------------------------	-------------------------------	--------------------------------	---------------------------------	-----------------------------------

## Model Configuration

Model	Ball screw lead	Stroke	With or without motor	Sensor	Option
①	②	③	④	⑤	⑥
VLAST60	06	0150	0	0	N
VLAST60	06: 6 mm 12: 12 mm	0050: 50 mm to 0700: 700 mm	0: Without motor  1: With motor (THK will purchase and mount the motor you specify)	0: Without 1 6 7 B E H L J M	N: None

If "0" is selected:  
No coupling will be attached. Please specify if a coupling is required when ordering.

If "1" is selected:  
The designated motor will be mounted. Please specify the motor cable direction separately.  
Please select the coupling, driver, and controller yourself.

## Selection Information

### Basic Specifications

LM Guide unit	Basic dynamic load rating C (N)		9120
	Basic static load rating C <sub>0</sub> (N)		8550
	Radial clearance (mm)		-0.005 to +0.005
	Geometric moment of inertia <sup>1,2,3</sup>	I <sub>x</sub> (mm <sup>4</sup> )	2.9 × 10 <sup>3</sup>
		I <sub>y</sub> (mm <sup>4</sup> )	5.21 × 10 <sup>4</sup>
Mass (kg/m)		1.52	
Ball screw	Ball screw lead (mm)	6	12
	Basic dynamic load rating C <sub>a</sub> (N)	4910	3600
	Basic static load rating C <sub>0a</sub> (N)	9600	6650
	Screw shaft diameter (mm)	φ12	
	Thread minor diameter (mm)	φ9.872	
	Ball center-to-center diameter (mm)	φ12.65	
Bearing (fixed side)	Axial direction	Basic dynamic load rating C <sub>a</sub> (N)	4400
		Static permissible load P <sub>0a</sub> (N)	1530
	Positioning repeatability (mm)		±0.02
	Backlash (mm)		0.1
	Permissible input torque (N·m)		1.23
	Static permissible moment <sup>5</sup> (N·m)		M <sub>A</sub> : 25.7, M <sub>B</sub> : 25.7, M <sub>C</sub> : 55
Standard grease		THK AFF Grease	

- This is the geometric moment of inertia for the LM Guide rail.
- I<sub>x</sub> is the geometric moment of inertia about the X axis.
- I<sub>y</sub> is the geometric moment of inertia about the Y axis.
- The permissible rotational speed may decrease as the stroke becomes longer.
- Static permissible moment is the maximum moment that can be permitted while the product is stationary.

Geometric moment of inertia

Static permissible moment

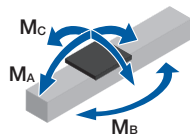
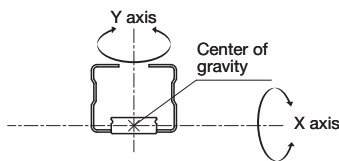

### Permissible Overhang Length<sup>7</sup>

Horizontal

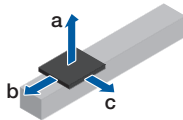

Wall-Mounted

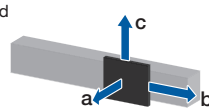

Vertical

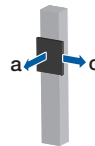

50 W	Ball screw lead (mm)	Load mass (kg)	a (mm)	b (mm)	c (mm)
Direct coupling	6	7	420	120	340
		14.5	230	60	160
		29.5	90	20	70
	12	3	420	320	420
		6	420	160	350
		12	280	70	170

50 W	Ball screw lead (mm)	Load mass (kg)	a (mm)	b (mm)	c (mm)
Direct coupling	6	5.5	330	150	420
		11	130	60	300
		22.5	40	20	150
	12	3	420	300	420
		6	290	140	420
		12	120	60	280

50 W	Ball screw lead (mm)	Load mass (kg)	a (mm)	c (mm)
Direct coupling	6	2.5	310	310
		5.5	120	140
		11.5	40	50
	12	1	420	420
		2.5	310	310
		5.5	120	140

100 W	Ball screw lead (mm)	Load mass (kg)	a (mm)	b (mm)	c (mm)
Direct coupling	6	7	420	120	340
		14.5	230	60	160
		29.5	90	20	70
	12	6	420	150	350
		12.5	270	70	160
		25	120	30	70

100 W	Ball screw lead (mm)	Load mass (kg)	a (mm)	b (mm)	c (mm)
Direct coupling	6	5.5	330	150	420
		11	130	60	300
		22.5	40	20	150
	12	5	360	170	420
		10	150	70	340
		20	50	20	170

100 W	Ball screw lead (mm)	Load mass (kg)	a (mm)	c (mm)
Direct coupling	6	2.5	310	310
		5.5	120	140
		11.5	40	50
	12	2.5	310	310
		5.5	120	140
		11	50	50

<sup>7</sup> This is the value with the service life of the LM Guide limited to 5,000 km. The calculation conditions are as follows.  
Stroke: 375 mm / Acceleration/deceleration: 0.3 G / Speed: 300 m/s (for a 6 mm lead), 600 m/s (for a 12 mm lead) / Overhang direction: Loaded only in a single direction. Dimensions a, b, and c are from the center of the table's upper surface.

## Motor Selection Specifications

Stroke (mm)	LM Guide		Ball screw		Motor mounting part
	Moving part mass (kg)	Sliding resistance (N)	Lead (mm)	Shaft length (mm)	Shaft end diameter (mm)
50 to 700	0.4	8.5	6, 12	184 to 834	φ6h8

## Compatible Motors

The motors given in the table below can be mounted without an intermediate flange.

Motor type	Manufacturer	Series	Motor model	Motor rated output (W)	Flange size	Compatible coupling model	
						MIKI PULLEY CO., LTD.	Nabeya Bi-tech Kaisha (NBK)
AC servo motor	Yaskawa Electric Corporation	Σ-V	SGMJV-A5	50	40 × 40	SFC-020DA2-6B-8B	XGT2-19C-6-8
			SGMAV-A5				
			SGMJV-01	100	40 × 40		
			SGMAV-01				
		Σ-7	SGM7J-A5	50	40 × 40		
			SGM7A-A5				
			SGM7J-01	100	40 × 40		
			SGM7A-01				
		Σ-X	SGMXJ-A5	50	40 × 40		
			SGMXA-A5				
			SGMXJ-01	100	40 × 40		
			SGMXA-01				
	Mitsubishi Electric Corporation	MELSERVO	J4	HG-KR053	50	40 × 40	
				HG-MR053			
				HG-KR13	100	40 × 40	
				HG-MR13			
			J5	HK-KT053W	50	40 × 40	
				HK-KT13W			
				HF-KN053	100	40 × 40	
				HF-KN13			
			JN				
			Tamagawa Seiki Co., Ltd.	TBL-II	TS4602	50	40 × 40
					TS4603	100	40 × 40
	TBL-IV	TSM3102		50	40 × 40		
		TSM3104		100	40 × 40		
	Keyence Corporation	SV	SV-M005	50	40 × 40		
			SV-M010	100	40 × 40		
		SV2	SV2-M005	50	40 × 40		
			SV2-M010	100	40 × 40		
	SANYO Electric	SANMOTION R	R2□A04005	50	40 × 40		
			R2□A04010	100	40 × 40		
	OMRON Corporation	OMNUC G5	R88M-K05030	50	40 × 40		
			R88M-K10030	100	40 × 40		
		1S	R88M-1M10030	100	40 × 40		
	FANUC CORPORATION	βis series	βis 0.2/5000	50	40 × 40		
βis0.3/5000			100	40 × 40			

Note 1) Please select a straight motor shaft.

Note 2) Please select the motor options (brakes, encoders, etc.) offered by each manufacturer. See each manufacturer's catalog for details about the motors.

Note 3) If the motor is changed to a type not listed above, the actuator specifications may change. Each recommended motor was selected based on the actuator specifications, so it cannot be used in excess of the actuator's rated conditions.

Note 4) If the specifications without a motor are selected, no coupling will be attached.

Note 5) If the maximum torque of the installed motor will exceed the permissible input torque (p. 11), please consider a safety measure to limit the torque.

# Dimensions

## Direct Motor Coupling

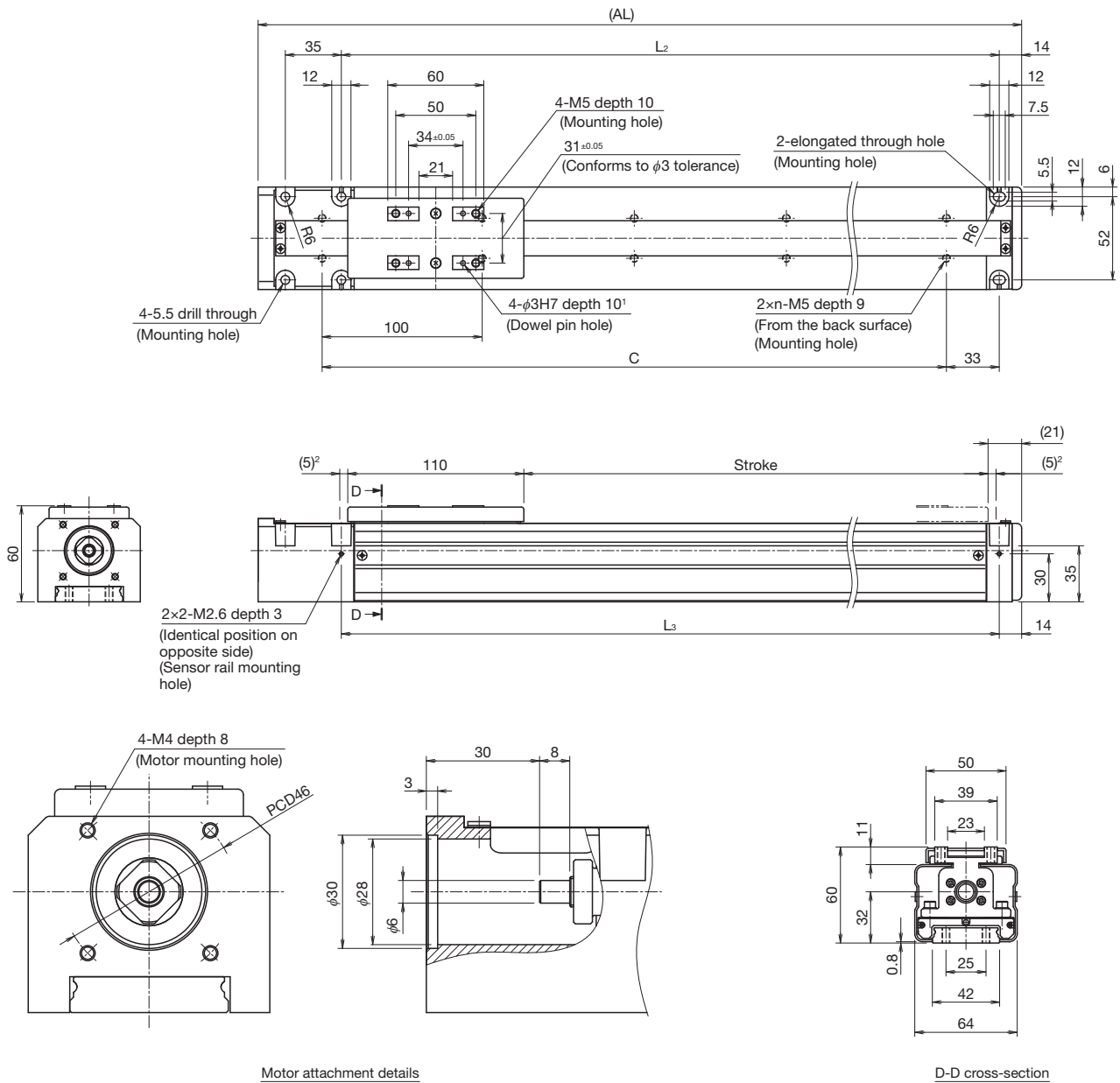

<sup>1</sup> These are through holes, so do not use a depth greater than 10 mm.  
<sup>2</sup> This is the stroke up to the mechanical stopper.

Stroke (mm) (Stroke between mechanical stoppers)		50 (60)	100 (110)	150 (160)	200 (210)	250 (260)	300 (310)	350 (360)	400 (410)	450 (460)	500 (510)	550 (560)	600 (610)	700 (710)	
Max. speed <sup>3</sup> (mm/s)	Ball screw lead: 6 mm	500						400						340	250
	Ball screw lead: 12 mm	1000						800						680	500
Dimensions (mm)	AL	237	287	337	387	437	487	537	587	637	687	737	787	887	
	L <sub>2</sub>	171	221	271	321	371	421	471	521	571	621	671	721	821	
	L <sub>3</sub>	171	221	271	321	371	421	471	521	571	621	671	721	821	
	C	100	200	200	300	300	400	400	500	500	600	600	700	800	
No. of mounting holes	n	2	3	3	4	4	5	5	6	6	7	7	8	9	
Mass (kg)		1.9	2.1	2.3	2.5	2.7	2.9	3.1	3.3	3.5	3.7	3.9	4.1	4.5	

<sup>3</sup> The maximum speed is restricted by the permissible speed of the actuator.

# Options

## Sensors

Optional photo sensors and proximity sensors are available.

If you select the sensor option, all sensor-related components will be included with the main actuator unit. Please perform the installation yourself.

See the following precautions (Notes 1 to 3) before using.

Symbol	Details	Model No.	Accessories
0	Without	—	—
1	Sensor rail	—	Mounting screw, sensor rail (x1)
6	Photo sensors <sup>1</sup> (x3)	EE-SX674 (OMRON Corporation)	Mounting screw/nut, sensor rail (x1), mounting plates (x3), connectors (EE-1001 x3)
7	Sensors: N.O. contact <sup>2</sup> (x3)	APM-D3A1-001 (Azbil Corporation)	Mounting screw/nut, sensor rail (x1)
B	Sensors: N.C. contact <sup>3</sup> (x3)	APM-D3B1-003 (Azbil Corporation)	Mounting screw/nut, sensor rail (x1)
E	Sensors: N.O. contact <sup>2</sup> (x1) N.C. contact <sup>3</sup> (x2)	APM-D3A1-001 (Azbil Corporation) APM-D3B1-003 (Azbil Corporation)	Mounting screw/nut, sensor rail (x1)
H	Sensors: N.O. contact <sup>2</sup> (x3)	GX-F12A (Panasonic Industrial Devices SUNX Co., Ltd.)	Mounting screw/nut, sensor rail (x1)
L	Sensors: N.C. contact <sup>3</sup> (x3)	GX-F12B (Panasonic Industrial Devices SUNX Co., Ltd.)	Mounting screw/nut, sensor rail (x1)
J	Sensors: N.O. contact <sup>2</sup> (x1) N.C. contact <sup>3</sup> (x2)	GX-F12A (Panasonic Industrial Devices SUNX Co., Ltd.) GX-F12B (Panasonic Industrial Devices SUNX Co., Ltd.)	Mounting screw/nut, sensor rail (x1)
M	Sensors: N.O. contact <sup>2</sup> (x1) (PNP output) N.C. contact <sup>3</sup> (x2) (PNP output)	GX-F12A-P (Panasonic Industrial Devices SUNX Co., Ltd.) GX-F12B-P (Panasonic Industrial Devices SUNX Co., Ltd.)	Mounting screw/nut, sensor rail (x1)

<sup>1</sup> The photo sensors can be switched between ON when lit and ON when unlit.

<sup>2</sup> N.O. contact: Normally open contact

<sup>3</sup> N.C. contact: Normally closed contact

Note 1) Sensor dogs cannot be mounted to the main actuator unit, so please mount them to another object such as a workpiece or jig.

Note 2) If proximity sensors are close to one another, they may not function properly. If that happens, please prepare a type with a different frequency.

Note 3) It is possible to install sensors other than those listed above. Contact THK for details.

### Photo Sensor Installation Method

Sensor dogs are not included with the sensor option. Please reference the dimensional drawing below to design a sensor dog and then install the sensor.

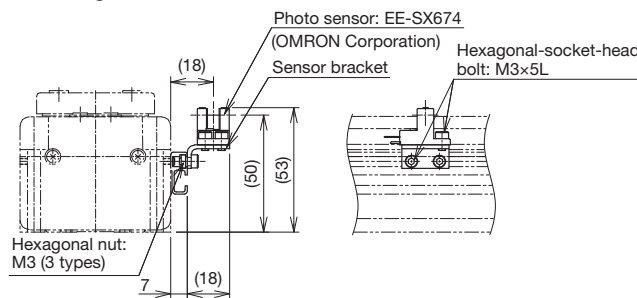

### Proximity Sensor Installation Method

Sensor dogs are not included with the sensor option. Please reference the dimensional drawing below to design a sensor dog and then install the sensor.

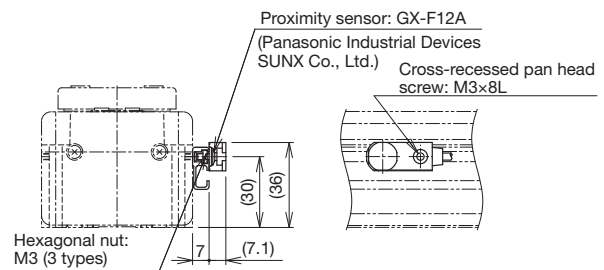

### Sensor Rail (Sold Separately)

Sensor Rail Model Number Coding

Model	Classification	Type	Stroke
① TH	② VSR	③ 60	④ 0100
TH	VSR	60: For VLAST60	0050: For 50 mm stroke to 0700: For 700 mm stroke

### Sensor Rail Dimensions

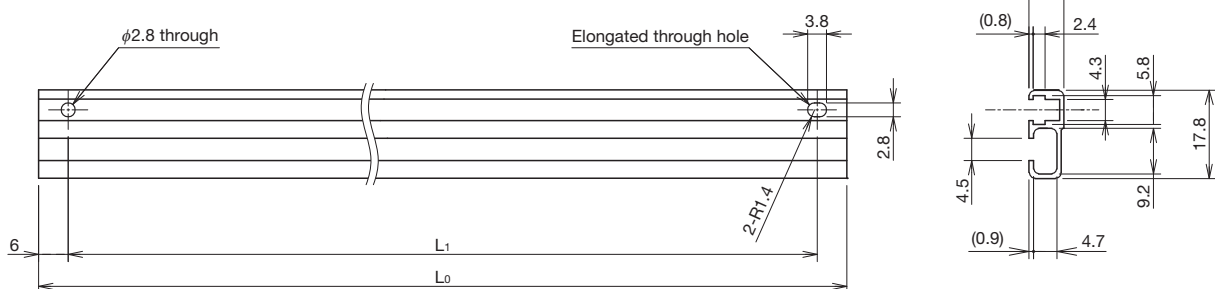

### TH-VSR-60

Stroke (mm)	50	100	150	200	250	300	350	400	450	500	550	600	700
Dimensions (mm)													
L <sub>1</sub>	171	221	271	321	371	421	471	521	571	621	671	721	821
L <sub>0</sub>	183	233	283	333	383	433	483	533	583	633	683	733	833

Note 4) Two No. 0 pan-head screws (M2.6x4L) are included for securing the sensor rail.

# VLACT35

Servo motor <b>50 W</b>	Type <b>Cylinder</b>	Motor Direct coupling	Body width <b>40 mm</b>	Body height <b>41 mm</b>	Max. stroke <b>150 mm</b>	Max. speed <b>600 mm/s</b>
----------------------------	-------------------------	-----------------------------	-------------------------------	--------------------------------	---------------------------------	----------------------------------

## Model configuration

Model ①	Ball screw lead ②	Stroke ③	With or without motor ④	Sensor ⑤	Option ⑥
VLACT35 <b>VLACT35</b>	06 06: 6 mm 12: 12 mm	0150 0050: 50 mm to 0150: 150 mm	0 0: Without motor 1: With motor (THK will purchase and mount the motor you specify)	0 0: Without	N N: None A: Bracket base B: Flange

If "0" is selected:  
With standard specifications, this product will be shipped with a coupling mounted on the main unit.  
If "1" is selected:

The designated motor will be mounted. Please specify the motor cable direction separately.  
Please select the driver and controller yourself.

### ⑥ Options

Bracket base (A)

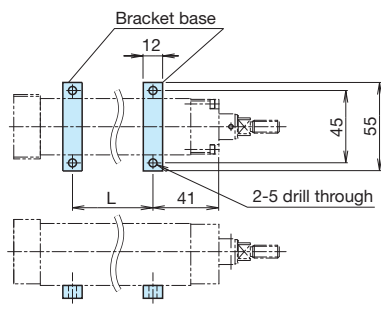

Stroke (mm)	L
50	100
100	150
150	200

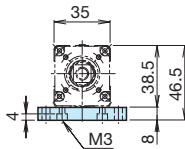

Flange (B)

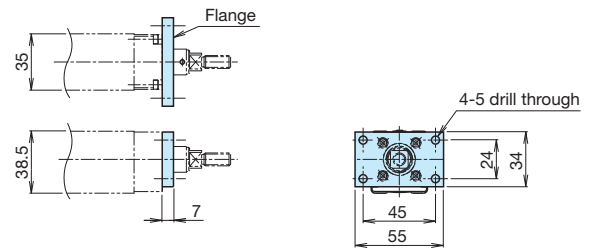

## Selection Information

### Basic Specifications

Ball screw	Ball screw lead (mm)		6	12
	Basic dynamic load rating $C_a$ (N)		1950	900
	Basic static load rating $C_0$ (N)		3510	1610
	Screw shaft diameter (mm)		$\phi 8$	
	Thread minor diameter (mm)		$\phi 6.8$	
	Ball center-to-center diameter (mm)		$\phi 8.4$	
	Permissible rotational speed <sup>1</sup> (min <sup>-1</sup> )		3000	
Bearing (fixed side)	Axial direction	Basic dynamic load rating $C_a$ (N)	5600	
		Static permissible load $P_0$ (N)	1280	
Positioning repeatability (mm)		$\pm 0.02$		
Permissible input torque (N·m)		1.35	1.4	
Standard grease		THK AFF Grease		

<sup>1</sup> The permissible rotational speed may decrease as the stroke becomes longer.

### ■ Horizontal

Estimated motor capacity (W)		50		
Ball screw lead (mm)		6	12	
Maximum load capacity <sup>2</sup> (kg)	Acceleration/ deceleration	0.15 G	8	-
		0.3 G	8	8
		0.5 G	-	8

### ■ Vertical

Estimated motor capacity (W)		50		
Ball screw lead (mm)		6	12	
Maximum load capacity <sup>2</sup> (kg)	Acceleration/ deceleration	0.15 G	8	-
		0.3 G	8	6
		0.5 G	-	5.5

<sup>2</sup> Maximum load capacity refers to the mass at the below speed.  
Speed: The rated rotational speed of the motor (3,000 min<sup>-1</sup>).

### Motor Selection Specifications

Stroke (mm)	Rod		Ball screw	
	Moving part mass (kg)	Sliding resistance (N)	Shaft length (mm)	Lead (mm)
50	0.19	10	127	6, 12
100	0.23		177	
150	0.28		227	

### Compatible Motors

The motors given in the table below can be mounted without an intermediate flange.

The coupling is built into the main actuator unit, so please select a straight motor shaft.

Motor type	Manufacturer	Series	Motor rated output (W)	Flange size	Motor model	
AC servo motor	Yaskawa Electric Corporation	$\Sigma$ -V	50	40 × 40	SGMJV-A5 SGMAV-A5	
		$\Sigma$ -7	50	40 × 40	SGM7J-A5 SGM7A-A5	
		$\Sigma$ -X	50	40 × 40	SGMXJ-A5 SGMXA-A5	
					HG-KR053 HG-MR053	
	Mitsubishi Electric Corporation	MELSERVO	J4	50	40 × 40	HK-KT053W HF-KN053
			J5	50	40 × 40	
			JN	50	40 × 40	
	Tamagawa Seiki Co., Ltd.	TBL-iII	50	40 × 40	TS4602	
		TBL-iIV	50	40 × 40	TSM3102	
	Keyence Corporation	SV	50	40 × 40	SV-M005	
		SV2	50	40 × 40	SV2-M005	
	SANYO Electric Corporation	SANMOTION R	50	40 × 40	R2□A04005	
	OMRON Corporation	OMNUC G5	50	40 × 40	R88M-K05030	

Note 1) Please select the motor options (brakes, encoders, etc.) offered by each manufacturer. See each manufacturer's catalog for details about the motors.

Note 2) If a motor other than the ones given in the table is selected, the actuator specifications may change. Each compatible motor was selected based on the actuator specifications, so it cannot be used in excess of the actuator's rated conditions.

Note 3) If the maximum torque of the installed motor will exceed the permissible input torque, please consider a safety measure to limit the torque.

# Dimensions

## Direct Motor Coupling

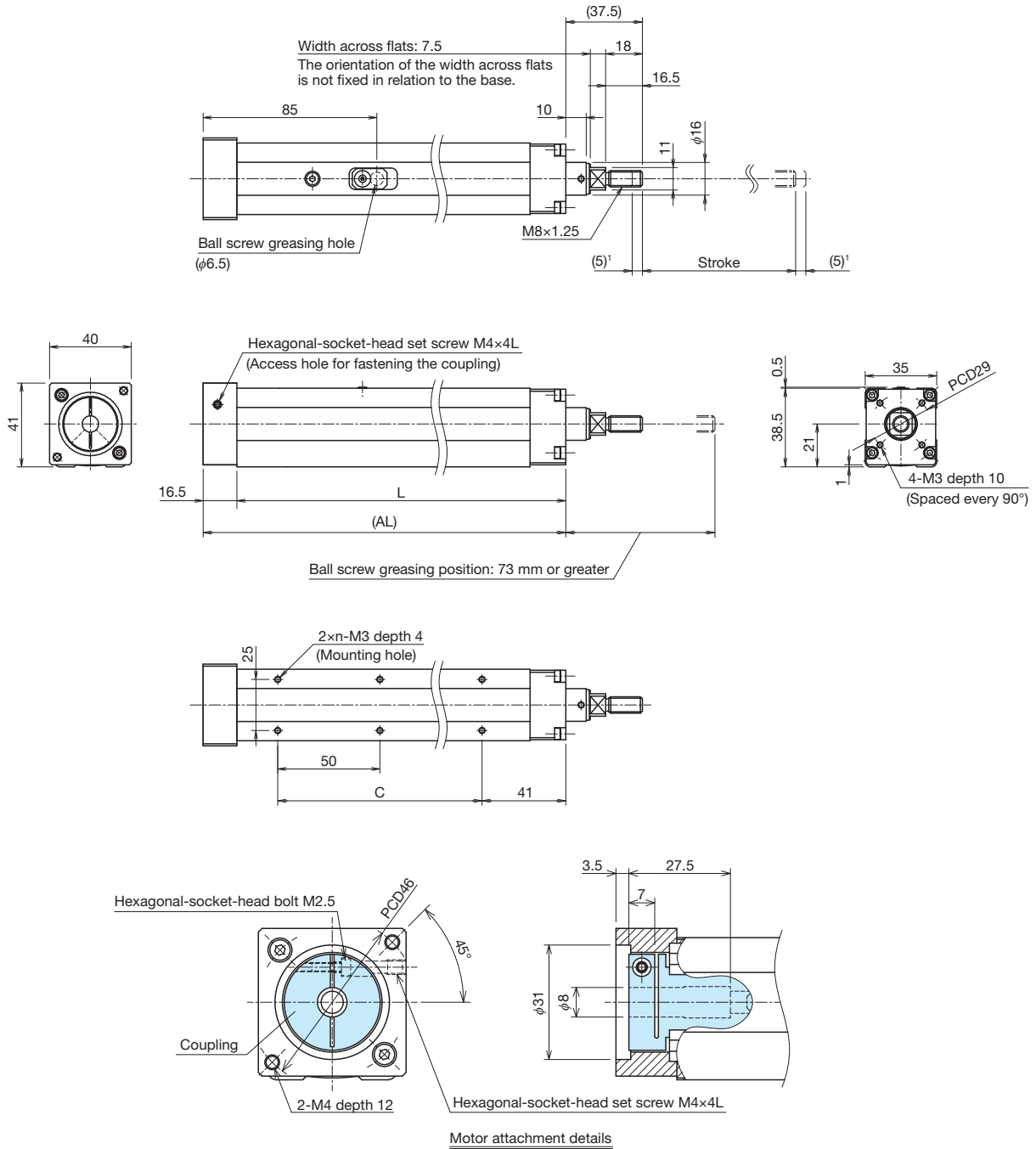

<sup>1</sup> This is the stroke up to the mechanical stopper.

Stroke (mm) (Stroke between mechanical stoppers)		50 (60)	100 (110)	150 (160)
Max. speed <sup>2</sup> (mm/s)	Ball screw lead: 6 mm		300	
	Ball screw lead: 12 mm		600	
Dimensions (mm)	AL	177.5	227.5	277.5
	L	161	211	261
	C	100	150	200
No. of mounting holes	n	6	8	10
Mass (kg)		0.7	0.9	1

<sup>2</sup> The maximum speed is restricted by the permissible speed of the actuator.

# VLACT45

Servo motor <b>50 W</b>	Type <b>Cylinder</b>	Motor Direct coupling	Body width <b>45 mm</b>	Body height <b>45 mm</b>	Max. stroke <b>200 mm</b>	Max. speed <b>600 mm/s</b>
----------------------------	-------------------------	-----------------------------	-------------------------------	--------------------------------	---------------------------------	----------------------------------

## Model Configuration

Model	Ball screw lead	Stroke	With or without motor	Sensor	Option
①	②	③	④	⑤	⑥
VLACT45	06	0150	0	0	N
<b>VLACT45</b>	<b>06:</b> 6 mm <b>12:</b> 12 mm	<b>0050:</b> 50 mm to <b>0200:</b> 200 mm	<b>0:</b> Without motor <b>1:</b> With motor (THK will purchase and mount the motor you specify)	<b>0:</b> Without	<b>N:</b> None <b>A:</b> Bracket base <b>B:</b> Flange

If "0" is selected:  
With standard specifications, this product will be shipped with a coupling mounted on the main unit.

If "1" is selected:

The designated motor will be mounted. Please specify the motor cable direction separately.  
Please select the driver and controller yourself.

## ⑥ Options

Bracket base (A)

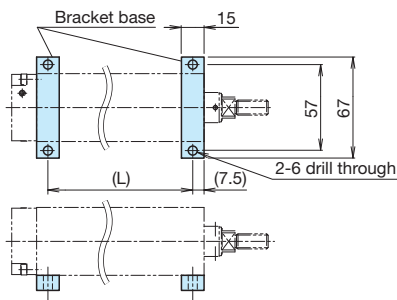

Stroke (mm)	L
50	147.5
100	197.5
150	247.5
200	297.5

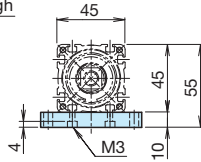

Flange (B)

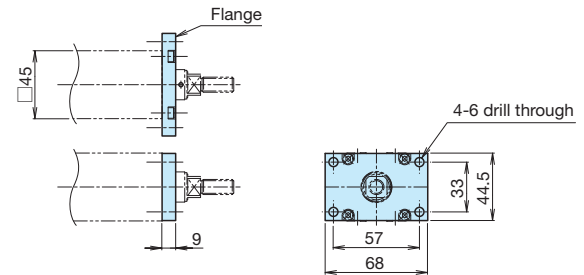

## Selection Information

### Basic Specifications

Ball screw	Ball screw lead (mm)		6	12
	Basic dynamic load rating $C_a$ (N)		1950	900
	Basic static load rating $C_{0a}$ (N)		3510	1610
	Screw shaft diameter (mm)		φ8	
	Thread minor diameter (mm)		φ6.8	
	Ball center-to-center diameter (mm)		φ8.4	
	Permissible rotational speed <sup>1</sup> (min <sup>-1</sup> )		3000	
Bearing (fixed side)	Axial direction	Basic dynamic load rating $C_a$ (N)	5600	
		Static permissible load $P_{0a}$ (N)	1280	
Positioning repeatability (mm)		±0.02		
Permissible input torque (N·m)		1.35	1.4	
Standard grease		THK AFF Grease		

<sup>1</sup> The permissible rotational speed may decrease as the stroke becomes longer.

### ■ Horizontal

Estimated motor capacity (W)		50		
Ball screw lead (mm)		6	12	
Maximum load capacity <sup>2</sup> (kg)	Acceleration/ deceleration	0.15 G	19	-
		0.3 G	19	13.5
		0.5 G	-	13.5

### ■ Vertical

Estimated motor capacity (W)		50		
Ball screw lead (mm)		6	12	
Maximum load capacity <sup>2</sup> (kg)	Acceleration/ deceleration	0.15 G	11.5	-
		0.3 G	11.5	6
		0.5 G	-	6

<sup>2</sup> Maximum load capacity refers to the mass at the below speed.  
Speed: The rated rotational speed of the motor (3,000 min<sup>-1</sup>).

### Motor Selection Specifications

Stroke (mm)	Rod		Ball screw	
	Moving part mass (kg)	Sliding resistance (N)	Shaft length (mm)	Lead (mm)
50	0.29	10	127	6, 12
100	0.36		177	
150	0.43		227	
200	0.5		277	

### Compatible Motors

The motors given in the table below can be mounted without an intermediate flange.

The coupling is built into the main actuator unit, so please select a straight motor shaft.

Motor type	Manufacturer	Series	Motor rated output (W)	Flange size	Motor model	
AC servo motor	Yaskawa Electric Corporation	Σ-V	50	40 × 40	SGMJV-A5	
					SGMAV-A5	
		Σ-7	50	40 × 40	SGM7J-A5	
					SGM7A-A5	
		Σ-X	50	40 × 40	SGMJX-A5	
					SGMXA-A5	
	Mitsubishi Electric Corporation	MELSERVO	J4	50	40 × 40	HG-KR053
			J5	50	40 × 40	HG-MR053
			JN	50	40 × 40	HF-KN053
	Tamagawa Seiki Co., Ltd.	TBL-III	50	40 × 40	TS4602	
		TBL-IIV	50	40 × 40	TSM3102	
	Keyence Corporation	SV	50	40 × 40	SV-M005	
		SV2	50	40 × 40	SV2-M005	
	SANYO Electric	SANMOTION R	50	40 × 40	R2□A04005	
OMRON Corporation	OMNUC G5	50	40 × 40	R88M-K05030		

Note 1) Please select the motor options (brakes, encoders, etc.) offered by each manufacturer. See each manufacturer's catalog for details about the motors.

Note 2) If a motor other than the ones given in the table is selected, the actuator specifications may change. Each compatible motor was selected based on the actuator specifications, so it cannot be used in excess of the actuator's rated conditions.

Note 3) If the maximum torque of the installed motor will exceed the permissible input torque, please consider a safety measure to limit the torque.

# Dimensions

## Direct Motor Coupling

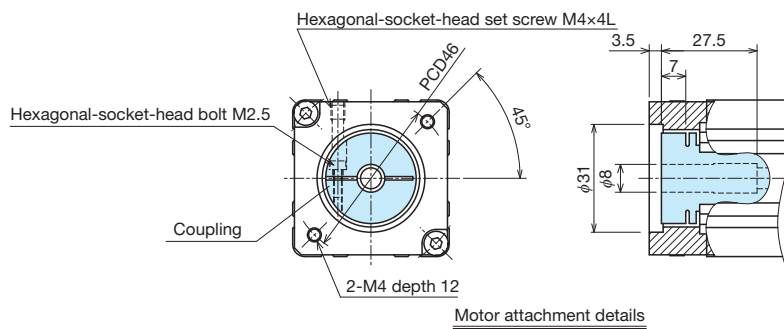
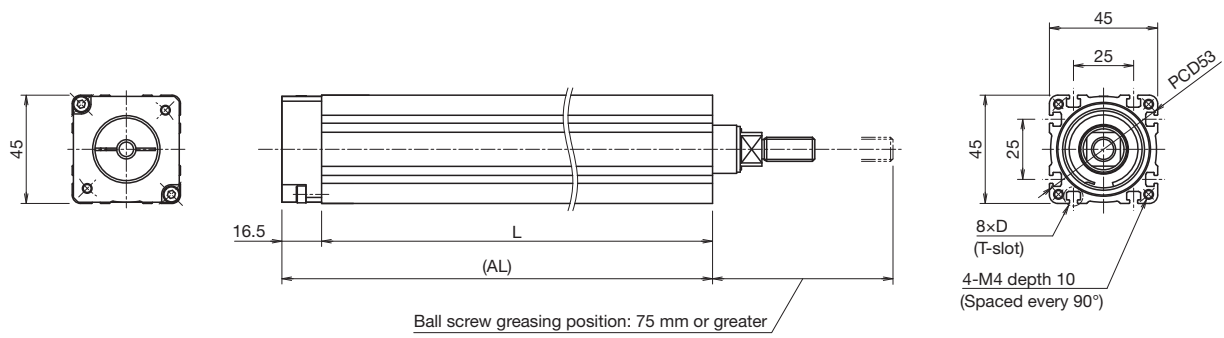
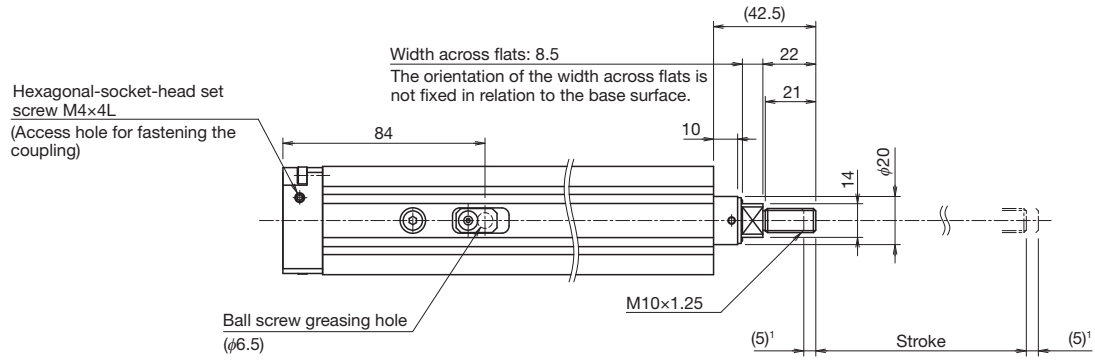

<sup>1</sup> This is the stroke up to the mechanical stopper.

Stroke (mm) (Stroke between mechanical stoppers)		50 (60)	100 (110)	150 (160)	200 (210)
Max. speed <sup>2</sup> (mm/s)	Ball screw lead: 6 mm	300			
	Ball screw lead: 12 mm	600			
Dimensions (mm)	AL	179	229	279	329
	L	162.5	212.5	262.5	312.5
Mass (kg)		1.1	1.4	1.6	1.9

<sup>2</sup> The maximum speed is restricted by the permissible speed of the actuator.

# VLACT55

Servo motor <b>100 W</b>	Type <b>Cylinder</b>	Motor Direct coupling	Body width <b>55 mm</b>	Body height <b>55 mm</b>	Max. stroke <b>300 mm</b>	Max. speed <b>600 mm/s</b>
-----------------------------	-------------------------	-----------------------------	-------------------------------	--------------------------------	---------------------------------	----------------------------------

## Model Configuration

Model	Ball screw lead	Stroke	With or without motor	Sensor	Option
①	②	③	④	⑤	⑥
VLACT55	06	0150	0	0	N
<b>VLACT55</b>	<b>06</b> : 6 mm <b>12</b> : 12 mm	<b>0050</b> : 50 mm to <b>0300</b> : 300 mm	<b>0</b> : Without motor <b>1</b> : With motor (THK will purchase and mount the motor you specify)	<b>0</b> : Without	<b>N</b> : None <b>A</b> : Bracket base <b>B</b> : Flange

If "0" is selected:  
With standard specifications, this product will be shipped with a coupling mounted on the main unit.  
If "1" is selected:  
The designated motor will be mounted. Please specify the motor cable direction separately.  
Please select the driver and controller yourself.

### ⑥ Options

Bracket base (A)

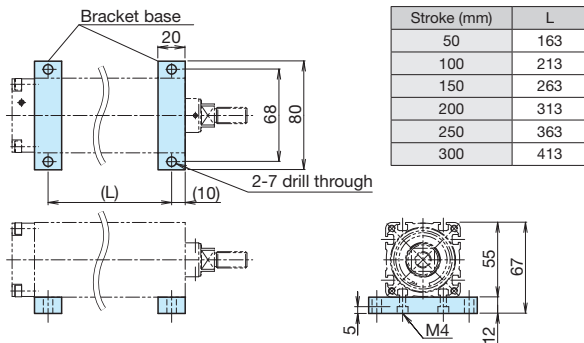

Flange (B)

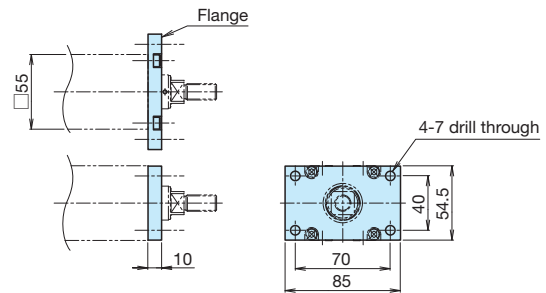

## Selection Information

### Basic Specifications

Ball screw	Ball screw lead (mm)		6	12
	Basic dynamic load rating Ca (N)		4910	3600
	Basic static load rating Ca (N)		9600	6650
	Screw shaft diameter (mm)		φ12	
	Thread minor diameter (mm)		φ9.872	
	Ball center-to-center diameter (mm)		φ12.65	
	Permissible rotational speed <sup>1</sup> (min <sup>-1</sup> )		3000	
Bearing (fixed side)	Axial direction	Basic dynamic load rating Ca (N)		9600
	Static direction	Static permissible load Pa (N)		2650
Positioning repeatability (mm)		±0.02		
Permissible input torque (N·m)		2.81	3.05	
Standard grease		THK AFF Grease		

<sup>1</sup> The permissible rotational speed may decrease as the stroke becomes longer.

#### ■ Horizontal

Estimated motor capacity (W)		100	
Ball screw lead (mm)		6	12
Maximum load capacity <sup>2</sup> (kg)	Acceleration/deceleration	0.15 G	56
		0.3 G	56
		0.5 G	-
		-	25

#### ■ Vertical

Estimated motor capacity (W)		100	
Ball screw lead (mm)		6	12
Maximum load capacity <sup>2</sup> (kg)	Acceleration/deceleration	0.15 G	23
		0.3 G	23
		0.5 G	-
		-	11.5

<sup>2</sup> Maximum load capacity refers to the mass at the below speed.  
Speed: The rated rotational speed of the motor (3,000 min<sup>-1</sup>).

### Motor Selection Specifications

Stroke (mm)	Rod		Ball screw unit	
	Moving part mass (kg)	Sliding resistance (N)	Shaft length (mm)	Lead (mm)
50	0.5	10	144	6, 12
100	0.61		194	
150	0.73		244	
200	0.84		294	
250	0.96		344	
300	1.07		394	

### Compatible Motors

The motors given in the table below can be mounted without an intermediate flange.

The coupling is built into the main actuator unit, so please select a straight motor shaft.

Motor type	Manufacturer	Series	Motor rated output (W)	Flange size	Motor model	
AC servo motor	Yaskawa Electric Corporation	Σ-V	100	40 × 40	SGMJV-01	
					SGMAV-01	
		Σ-7	100	40 × 40	SGM7J-01	
					SGM7A-01	
		Σ-X	100	40 × 40	SGMXJ-01	
					SGMXA-01	
	Mitsubishi Electric Corporation	MELSERVO	J4	100	40 × 40	HG-KR13
			J5	100	40 × 40	HG-MR13
			JN	100	40 × 40	HF-KN13
	Tamagawa Seiki Co., Ltd.	TBL-III	100	40 × 40	TS4603	
		TBL-IV	100	40 × 40	TSM3104	
	Keyence Corporation	SV	100	40 × 40	SV-M010	
		SV2	100	40 × 40	SV2-M010	
	SANYO Electric	SANMOTION R	100	40 × 40	R2□A04010	
	OMRON Corporation	OMNUC G5	100	40 × 40	R88M-K10030	
1S		100	40 × 40	R88M-1M10030		

Note 1) Please select the motor options (brakes, encoders, etc.) offered by each manufacturer. See each manufacturer's catalog for details about the motors.

Note 2) If a motor other than the ones given in the table is selected, the actuator specifications may change. Each compatible motor was selected based on the actuator specifications, so it cannot be used in excess of the actuator's rated conditions.

Note 3) If the maximum torque of the installed motor will exceed the permissible input torque, please consider a safety measure to limit the torque.

# Dimensions

## Direct Motor Coupling

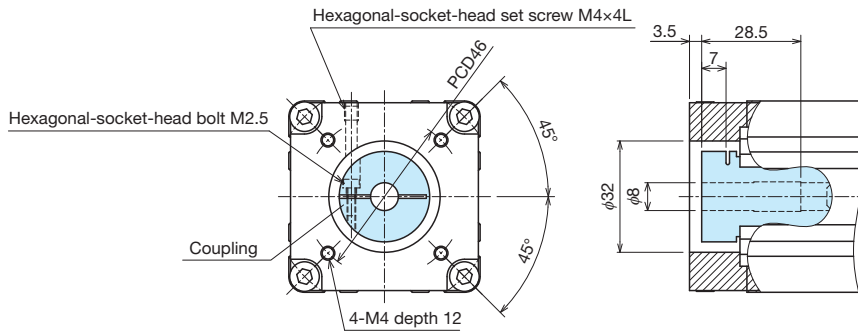
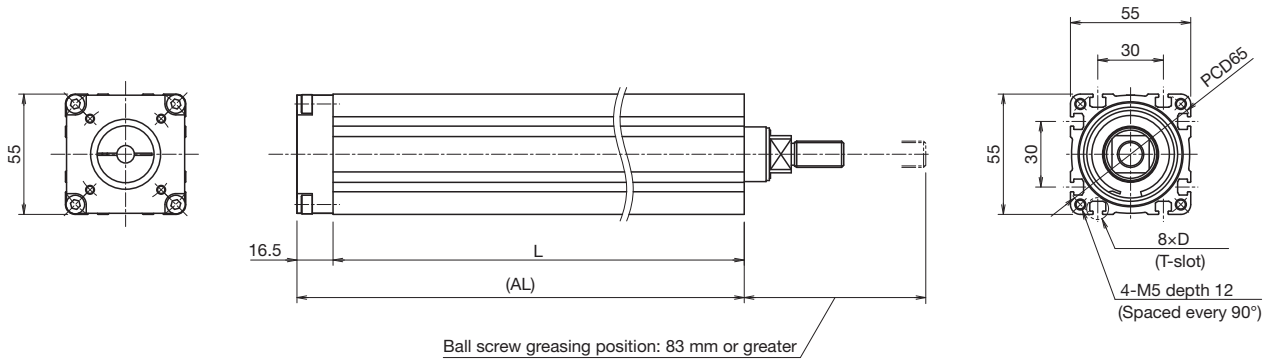
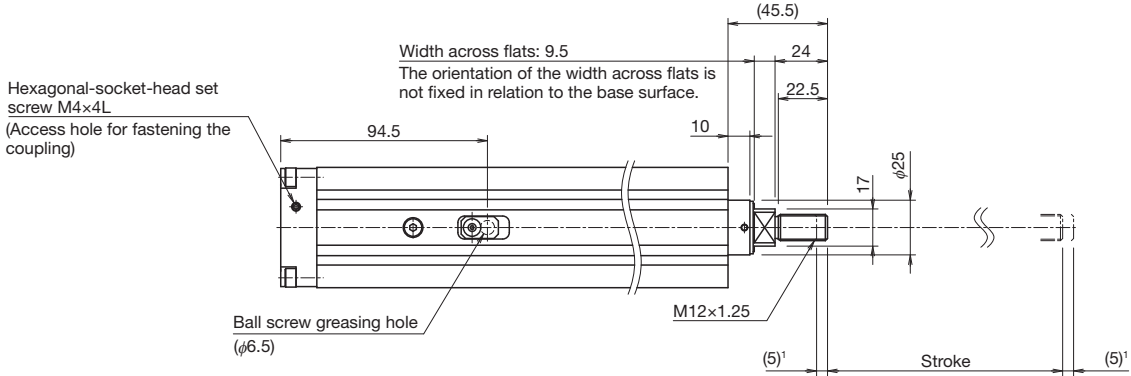

Motor attachment details

<sup>1</sup> This is the stroke up to the mechanical stopper.

Stroke (mm) (Stroke between mechanical stoppers)		50 (60)	100 (110)	150 (160)	200 (210)	250 (260)	300 (310)
Max. speed <sup>2</sup> (mm/s)	Ball screw lead: 6 mm			300			235
	Ball screw lead: 12 mm			600			470
Dimensions (mm)	AL	199.5	249.5	299.5	349.5	399.5	449.5
	L	183	233	283	333	383	433
Mass (kg)		1.7	2.1	2.5	2.8	3.2	3.6

<sup>2</sup> The maximum speed is restricted by the permissible speed of the actuator.

## Precautions for Use

### Application of These Products

- These products cannot be used for equipment or systems used in situations involving human life and limb.
- Be certain to contact THK in advance if considering utilizing for special applications, such as devices or systems used in passenger vehicles, medical equipment, aerospace, nuclear power, or electric power equipment.

### Rotational Motor Drive Products

#### Handling

- When using the product in locations exposed to constant vibrations or in special environments such as in clean rooms, vacuums, and low/high temperatures, contact THK.
- Tilting the table or the outer rail may cause them to fall due to their own weight.

#### Safety Precautions

- Before operation, thoroughly read and follow "Manipulating industrial robots - Safety" (JIS B 8433) and "Ordinance on Industrial Safety and Health" (Ministry of Health, Labour and Welfare of Japan).
- Be certain to read the instruction manual carefully, ensure you fully understand its contents, and observe precautions for safety.
- When installing, adjusting, inspecting, and maintaining the actuator body and related connected devices, be sure to unplug all plugs from outlets and lock them or prepare a safety plug so that the power cannot be turned on except by the operator. In a visible location, post a notice clearly stating that work is in progress.
- Never touch the operating parts of the actuator while it is live. Also, do not enter the operating range of the actuator while the product is in operation or a ready state.
- If multiple people are involved in the operation, confirm procedures such as work process, signs, and abnormalities in advance, and appoint a separate person for monitoring the operation.
- Do not disassemble these products unnecessarily. Doing so may lead to contamination by foreign materials or deterioration in accuracy.
- Take care not to drop or strike this product. Otherwise, it may cause injury or damage the unit. Even if there is no outward indication of damage, a sudden impact could prevent the unit from functioning properly.
- Do not exceed the permissible rotation speed when using the product. This could damage the product or otherwise cause it to malfunction. Please use the product within the range of speeds we have specified.
- Take care to avoid contamination of foreign material such as debris or cutting chips. This may result in damage to the ball circulation parts or decreased functionality.
- Contact THK regarding use in environments where coolant may enter the product.
- An impact-absorbing mechanism such as a shock absorber must be installed if there is a risk that the slider may collide with the stoppers attached to both ends of the movable range. The stoppers are not intended to absorb impacts during slider collision. Colliding with the stoppers during operation may result in damage or injury.
- Operation of the actuator over the torque limit value may lead to component damage or accidents.
- Keep the torque limit setting parameters within the allowable torque limit values.
- Motor wrap types do not include a safety device to protect users if the timing belt snaps. The customer must provide a safety device.
- Among these products are those with a total body weight exceeding 20 kg. When transporting or assembling, always take safety into consideration to avoid injury or damage, and use appropriate conveying equipment.
- In applications where this product will be moved or transferred, the conditions of use may cause inertia from the motor's weight to result in damage to the motor attachment (Housing A) or other parts. Please contact THK before using in this manner.
- In applications where this product will be moved or transferred, the conditions of use may cause inertia from the motor's weight to result in damage to the motor attachments (Housing A and motor bracket) or other parts. Please contact THK before using in this manner.

#### Operating Environment

- Indoors, ambient temperature between 0°C to 40°C, and ambient humidity of 80% RH or less (no freezing or condensation).
- Places free from corrosive gas and flammable gas.
- Places where vibrations and impacts are not transmitted to the unit.
- Places free from electrically conductive powder (such as iron powder), dust, oil mist, moisture, salt, and organic solvents.
- Places free from direct sunlight and radiant heat.
- Places free from strong electric and magnetic fields.
- Places that are easily accessible for maintenance and cleaning.
- When using the product in locations exposed to constant vibrations or in special environments such as in vacuums or low/high temperatures, contact THK.

#### Actuator Mounting Surface

- Mount to a flat surface suitable for mechanical machining or with comparable precision. Some products have required degrees of flatness.
- Mount to a base with sufficient rigidity.
- VLAST45: within 0.05 mm/200 mm, VLAST60: within 0.06 mm/200 mm

#### Lubrication

- For effective use of the actuator's functions, lubrication is required. Insufficient lubrication may cause greater wear on moving parts, leading to premature damage.
- Do not use a mix of lubricants with different properties. Note that the included lubricant may differ depending on the product.
- Contact THK if using special lubricants.
- 100 km should be considered a guideline for greasing intervals. However, this may vary depending on the operating conditions, so THK recommends determining a greasing interval during the initial inspection.
- Regular lubricant may not be usable in special environments such as constantly vibrating locations, vacuums, high/low temperatures, or clean rooms. Contact THK in these cases.
- Contact THK if using oil lubrication.
- Thoroughly wipe off anti-rust oil and feed lubricant before using the product.

#### Storage

- When storing this actuator, pack it as designated by THK and store it in a horizontal position away from high or low temperatures and high humidity.
- When storing the controller, avoid high or low temperatures and high humidity.

#### Disposal

- The product should be treated as industrial waste and disposed of appropriately.



## Other Recommended Products



### Caged Ball LM Guide Actuator SKR

- Modular structure reduces the number of parts, design hours, and assembly hours
- Caged ball effect enables a long service life and long-term maintenance-free operation
- Ideal for high-precision positioning and orthogonal, multi-axis designs



### LM Guide Actuator KR

- Modular structure reduces the number of parts, design hours, and assembly hours
- Can be used in various orientations, including horizontal, wall-mounted, vertical, and hanging
- Extensive lineup of 9 sizes

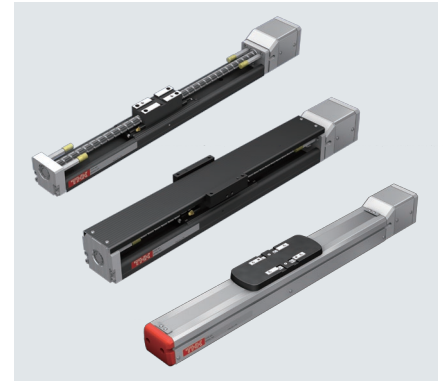

### LM Guide Actuator with Large-Diameter Ball Screw KSF

Open cover/top cover/fully enclosed

- Large-diameter ball screw enables high-speed and high-acceleration/deceleration operations
- 3 types of cover options to choose from to suit the application
- Supports long strokes up to 1500 mm

## Economy Series Electric Actuator VLAST/VLACT

### ● LM Guide and Caged Ball are registered trademarks of THK CO., LTD.

- The actual products may differ from the illustrations and photographs in this catalog.
- Outward appearances and specifications are subject to change without notice for the purpose of improvement. Please consult with THK before using.
- Although great care has been taken in the production of this catalog, THK will not take any responsibility for damages resulting from typographical errors or omissions.
- For exports of our products and technologies and sales for export, our basic policy is to comply with the Foreign Exchange and Foreign Trade Act and other laws and regulations. Please consult us in advance if you want to export our products by the piece.

All rights reserved.

# THK CO., LTD.

Headquarters 2-12-10 Shibaura, Minato-ku, Tokyo 108-8506 Japan

International Sales Department Phone: +81-3-5730-3860

[www.thk.com](http://www.thk.com)

#### North America

THK America, Inc.

- Headquarters.....Phone: +1-847-310-1111
- Chicago Office.....Phone: +1-847-310-1111
- North East Office.....Phone: +1-847-310-1111
- Atlanta Office.....Phone: +1-770-840-7990
- Los Angeles Office.....Phone: +1-949-955-3145
- San Francisco Office.....Phone: +1-925-455-8948
- Detroit Office.....Phone: +1-248-858-9330
- Toronto Office.....Phone: +1-905-820-7800

#### South America

THK BRAZIL INDUSTRIA E COMERCIO LTDA.

Phone: +55-11-3767-0100

#### Europe

THK GmbH

- European Headquarters.....Phone: +49-2102-7425-555
- Düsseldorf Office.....Phone: +49-2102-7425-0
- Stuttgart Office.....Phone: +49-7141-4988-500
- U.K. Office.....Phone: +44-1384-471550
- Italy Office.....Phone: +39-02-9901-1801

- Sweden Office.....Phone: +46-8-445-7630
- Austria Office.....Phone: +43-7229-51400
- Spain Office.....Phone: +34-93-652-5740
- Turkey Office.....Phone: +90-216-362-4050
- Prague Office.....Phone: +420-2-41025-100
- Moscow Office.....Phone: +7-495-649-80-47
- THK Europe B.V.
- Eindhoven Office.....Phone: +31-40-290-9500
- THK France S.A.S.
- Paris Office.....Phone: +33-1-7425-3800

#### China

THK (CHINA) CO., LTD.

- Headquarters.....Phone: +86-411-8733-7111
- Shanghai Branch.....Phone: +86-21-6219-3000
- Beijing Branch.....Phone: +86-10-8441-7277
- Chengdu Branch.....Phone: +86-28-8526-8025
- Guangzhou Branch.....Phone: +86-20-8523-8418
- Shenzhen Branch.....Phone: +86-755-2642-9587
- Xian Branch.....Phone: +86-29-8834-1712
- THK (SHANGHAI) CO., LTD.....Phone: +86-21-6275-5280

#### Taiwan

THK TAIWAN CO., LTD.

- Taipei Headquarters.....Phone: +886-2-2888-3818
- Taichung Office.....Phone: +886-4-2359-1505
- Tainan Office.....Phone: +886-6-289-7668

#### South Korea

- Seoul Representative Office.....Phone: +82-2-3468-4351

#### Singapore

THK LM System Pte. Ltd.....Phone: +65-6884-5500

#### Thailand

THK RHYTHM (THAILAND) CO., LTD. LM System Division

- Bangkok Branch.....Phone: +66-2751-3001

#### India

THK India Pvt. Ltd.

- Headquarters & Bengaluru Branch.....Phone: +91-80-2340-9934
- Pune Branch.....Phone: +91-72-7600-2071
- Chennai Branch.....Phone: +91-44-4323-5430
- Ahmedabad Branch.....Phone: +91-79-4890-0041
- Delhi Branch.....Phone: +91-124-401-0885