

SRN

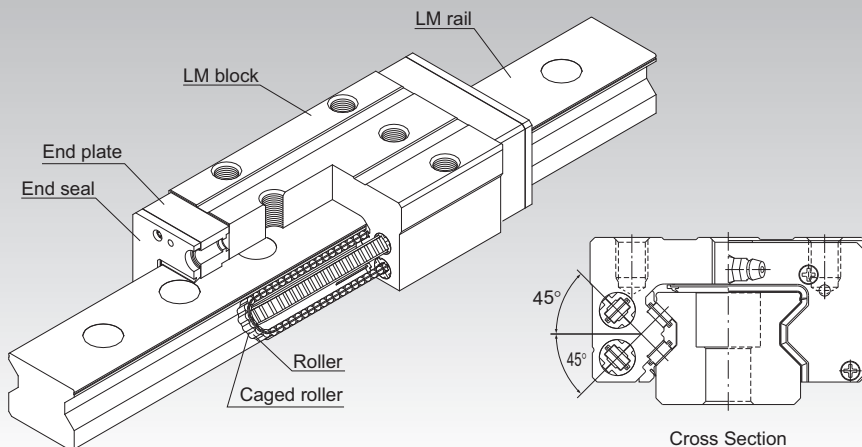

Ultra-Rigid, Low-Profile Caged Roller LM Guide Model SRN



Note: For the caged roller, see **A1-414**.

Selection Criteria **A1-10**

Design Highlights **A1-482**

Options **A1-507**

Model No. **A1-577**

Handling Precautions **A1-583**

Accessories for Lubrication **A24-1**

Mounting Procedure **B1-89**

Equivalent Moment Factor **A1-43**

Rated Loads in All Directions **A1-61**

Equivalent Factor in Each Direction **A1-63**

Radial Clearance **A1-75**

Accuracy Standards **A1-79**

Shoulder Height of the Mounting Base and the Corner Radius **A1-494**

Reference Error Tolerance for the Mounting Surface **A1-446**

Dimensions of Each Model with Options Attached **A1-521**

Structure and Features

Rollers roll in four rows of raceways precision-ground on the LM rail and LM block, and roller cages and end plates incorporated in the LM block allow the balls to circulate.

The SRN is an ultra-rigid roller guide that uses roller cages to allow low-friction, smooth motion and achieve long-term maintenance-free operation.

Ultra-High Rigidity

Increased rigidity is achieved by using highly rigid rollers as the rolling elements and having the overall roller length more than 1.5 times greater than the roller diameter.

4-Way Equal Load

Each row of rollers is arranged at a 45° contact angle so the LM block will have an equal load rating in all directions: radial, reverse-radial, and horizontal. This ensures high rigidity in all directions.

Smooth Motion through Skewing Prevention

The roller cage allows rollers to form an evenly spaced line while circulating, thus preventing the rollers from skewing as the block enters a loaded area. This minimizes rolling resistance fluctuation and achieves stable, smooth motion.

Long-Term Maintenance-Free Operation

Use of roller cages eliminates friction between rollers and increases grease retention, enabling long-term maintenance-free operation to be achieved.

Low-Profile, Low Center of Gravity

Because it has a lower total height than the Caged Roller LM Guide Model SRG, it is ideal for compact designs.

Types and Features

Model SRN-C

The flange of the LM block has tapped holes. It can be mounted from the top or the bottom. It is used in places where the table cannot have through holes for mounting bolts.

Dimensional Table⇒ **A1-448**

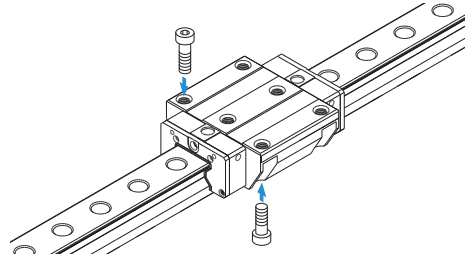

Model SRN-LC

The LM block has the same cross-sectional shape as model SRN-C, but has a longer overall LM block length (L) and a greater load rating.

Dimensional Table⇒ **A1-448**

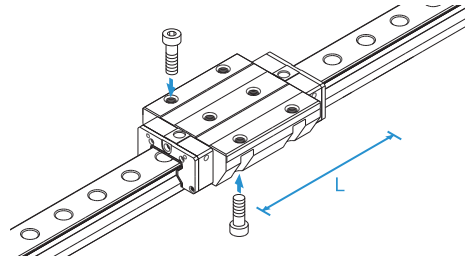

Model SRN-SLC

The LM block has the same cross-sectional shape as model SRN-LC, but has a longer overall LM block length (L) and a greater load rating.

Dimensional Table⇒ **A1-448**

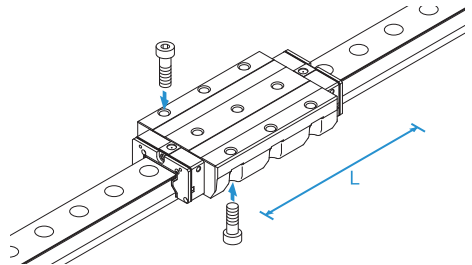

Model SRN-R

With this type, the LM block has a smaller width (W) and tapped holes. It is used in places where the space for table width is limited.

Dimensional Table⇒ [A1-452](#)

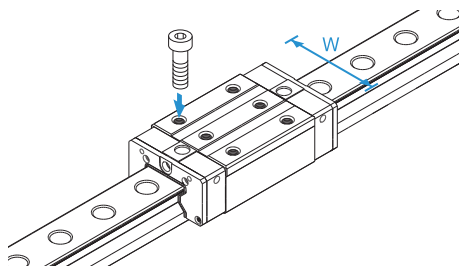

Model SRN-LR

The LM block has the same cross-sectional shape as model SRN-R, but has a longer overall LM block length (L) and a greater load rating.

Dimensional Table⇒ [A1-452](#)

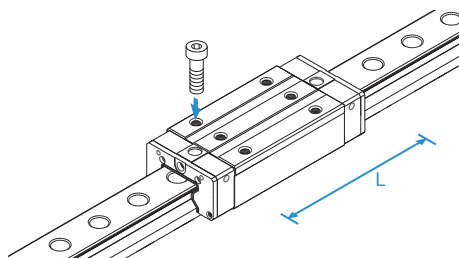

Model SRN-SLR

The LM block has the same cross-sectional shape as model SRN-LR, but has a longer overall LM block length (L) and a greater load rating.

Dimensional Table⇒ [A1-452](#)

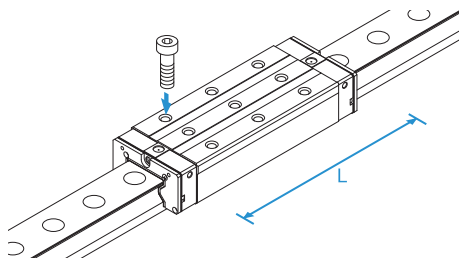

SRN-G

The SRN-G, a model equipped with uncaged, full-complement bearings, is also available. Due to its cageless design, however, the SRN-G's dynamic load rating is lower than that of standard SRN models. For specific data, please refer to the dimension tables in this catalog.

Dimensional Table⇒ [A1-448](#) to [A1-455](#)

Reference Error Tolerance for the Mounting Surface

The Caged Roller LM Guide Model SRN features high rigidity because it uses rollers as its rolling element, and it also features a roller cage, which prevents the rollers from skewing. However, high machining accuracy is required in the mounting surface. If the error on the mounting surface is large, it will affect the rolling resistance and the service life. The following shows the reference error tolerance according to the radial clearance.

Table 1: Reference Horizontal Error Tolerance (P) between Two Rails

Unit: μm

Radial clearance	Normal	C1	C0
Model No.			
SRN 35	14	10	7
SRN 45	17	13	9
SRN 55	21	14	11
SRN 65	27	18	14

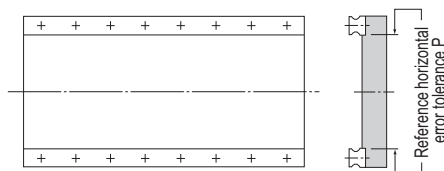

Fig. 1

Table 2: Reference Vertical Error Tolerance (X) between Two Rails

Unit: mm

Radial clearance	Normal	C1	C0
Reference vertical error tolerance X	0.0003a	0.00021a	0.00011a

$$X = X_1 + X_2 \quad X_1 : \text{Level difference on the rail mounting surface}$$

$$X_2 : \text{Level difference on the block mounting surface}$$

Example of calculation

Rail span when $a = 500 \text{ mm}$

$$\begin{aligned} \text{Reference vertical error tolerance } X &= 0.0003 \times 500 \\ &= 0.15 \end{aligned}$$

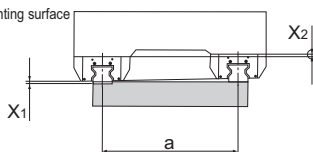

Fig. 2

Table 3: Reference Vertical Error Tolerance (Y) in the Axial Direction

Unit: mm

Reference vertical error tolerance Y	0.000036b
--------------------------------------	-----------

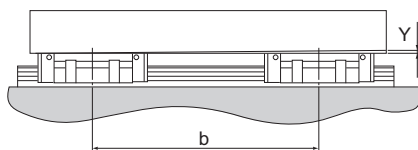
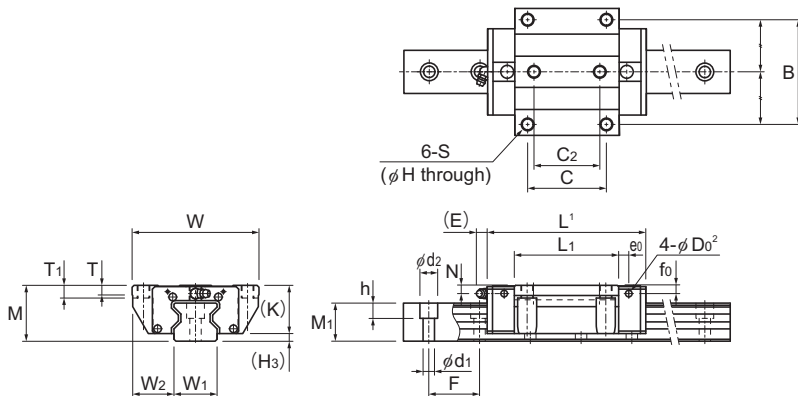

Fig. 3

Models SRN-C, SRN-LC, and SRN-SLC



Models SRN35 and 45 C/LC

Model No.	Outer dimensions			LM block dimensions													Pilot hole for side nipple			
	Height M	Width W	Length ¹ L	B	C	C ₂	S	H	L ₁	T	T ₁	K	N	E	Grease nipple	e _s	f ₀	D ₀ ²	H ₃	
SRN 35C SRN 35GC	44	100	125	82	62	52	M10	8.5	82.2	11.6	10	38	6.5	12	B-M6F	8	7	5.2	6	
SRN 35LC SRN 35GLC	44	100	155	82	62	52	M10	8.5	112.2	11.6	10	38	6.5	12	B-M6F	8	7	5.2	6	
SRN 35SLC SRN 35GSLC	44	100	180.8	82	100	—	M10	8.5	138	11.7	10	38	6.5	12	B-M6F	8	7	5.2	6	
SRN 45C SRN 45GC	52	120	155	100	80	60	M12	10.5	107	16.5	15	45	7	12	B-M6F	8.5	7.6	5.2	7	
SRN 45LC SRN 45GLC	52	120	190	100	80	60	M12	10.5	142	16.5	15	45	7	12	B-M6F	8.5	7.6	5.2	7	
SRN 45SLC SRN 45GSLC	52	120	231.5	100	120	—	M12	10.5	183.5	16.5	15	45	7	12	B-M6F	8.5	7.6	5.2	7	

Model number coding

SRN45 C 2 QZ KK C0 +1200L P Z T - II

Model number	Type of LM block	With QZ lubricator	Contamination protection accessory symbol	LM rail length (in mm)	With plate cover	Symbol for No. of rails used on the same plane
	No. of LM blocks used on the same rail		Radial clearance symbol Normal (No symbol)/Light preload (C1) Medium preload (C0)/Heavy preload (CN1) Super heavy preload (CN2)		Symbol for LM rail jointed use	
				Accuracy symbol High accuracy grade (H)/Precision grade (P) Super precision grade (SP)/Ultra precision grade (UP)		

Notes: This model number indicates that a single-rail unit constitutes one set (i.e., required number of sets when 2 rails are used in parallel is 2 at a minimum).

Grease nipples are not installed when there is a QZ Lubricator. Contact THK if you want to use a grease nipple for a model with a QZ. See **A1-547** for contamination protection accessories, see **A1-75** for radial clearance symbol, See **A1-79** for accuracy symbol. See **A1-13** for symbol for number of rails used on the same plane.

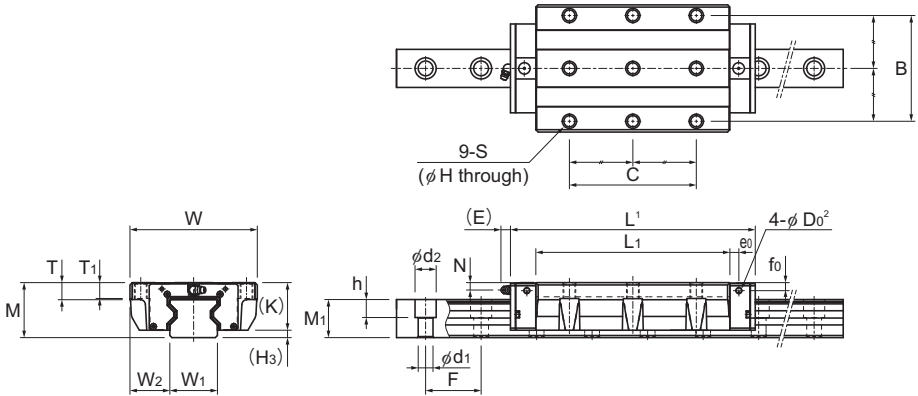

Models SRN35 and 45 SLC

Unit: mm

LM rail dimensions						Basic load rating ¹		Static permissible moment kN·m ³					Mass	
Width W ₁ 0 -0.05	W ₂	Height M ₁	Pitch F	d ₁ × d ₂ × h	Length ³ Max	C kN	C ₀ kN	M _A		M _B		M _C	LM block kg	LM rail kg/m
								1 block	2 blocks	1 block	2 blocks	1 block		
34	33	30	40	9 × 14 × 12	3000	59.1	119	1.66	10.1	1.66	10.1	2.39	1.5	6.9
						55.3	131	1.77	11.1	1.77	11.1	2.69		
34	33	30	40	9 × 14 × 12	3000	76	165	3.13	17	3.13	17	3.31	2.3	6.9
						71.4	182	3.39	18.8	3.39	18.8	3.74		
34	33	30	40	9 × 14 × 12	3000	87.9	199	4.53	23.9	4.53	23.9	4.09	2.8	6.9
						83.4	222	5	26.6	5	26.6	4.56		
45	37.5	36	52.5	14 × 20 × 17	3090	91.9	192	3.49	20	3.49	20	4.98	3.1	11.3
						87.8	216	3.9	22.5	3.9	22.5	5.87		
45	37.5	36	52.5	14 × 20 × 17	3090	115	256	6.13	32.2	6.13	32.2	6.64	4.1	11.3
						110	288	6.87	36.3	6.87	36.3	7.83		
45	37.5	36	52.5	14 × 20 × 17	3090	139	328	9.99	50	9.99	50	8.91	5.4	11.3
						133	368	11.1	56	11.1	56	10		

¹ Length L shown in the table is the length with the contamination protection accessories, code UU or SS.

If other contamination protection accessories or lubricant equipment are installed, the total block length will increase. (See [A1-521](#) or [A1-543](#))

² D₀ are the pilot holes for when a grease nipple is desired for a product with LaCS or a QZ Lubricator.

Pilot holes are not drilled through for models other than those stated above.

For grease nipple mount machining, contact THK.

³ The maximum length indicates the standard maximum length of an LM rail. (See [A1-456](#).)

⁴ The basic dynamic load rating of the roller guide is a value based on a nominal life of 100 km.

The conversion to basic dynamic load rating for a nominal life of 50 km can be obtained from the following equation.

$$C_{50} = C \times 1.23$$

C₅₀ : The basic dynamic load rating for a nominal load of 50 km

C : The basic dynamic load rating in the dimensional table

⁵ Static permissible moment

1 block: the static permissible moment with one LM block

2 blocks: the static permissible moment with two LM blocks in close contact with each other

Notes: The SRN-G is a cageless, Full-Roller type.

For oil lubrication, be certain to let THK know the mounting orientation and where the LM block piping joint should be attached.

(Mounting orientation: see [A1-12](#), Lubricant: see [A24-2](#))

The removing/mounting jig is not provided as standard. To obtain one, please contact THK.

Models SRN-C, SRN-LC, and SRN-SLC

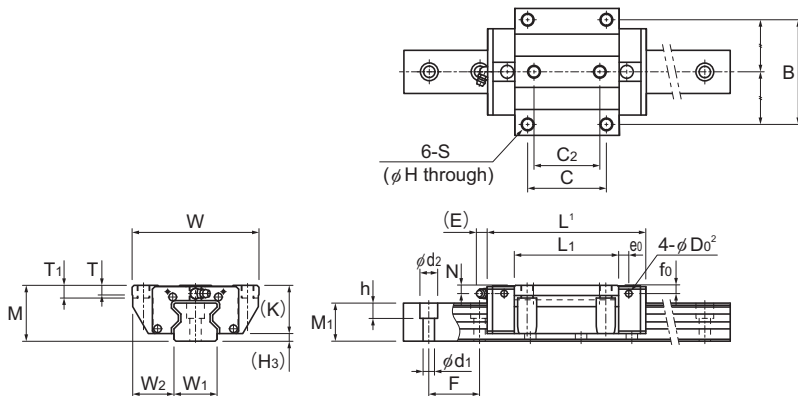

Models SRN55 and 65 C/LC

Model No.	Outer dimensions			LM block dimensions													Pilot hole for side nipple			
	Height M	Width W	Length ¹ L	B	C	C ₂	S	H	L ₁	T	T ₁	K	N	E	Grease nipple	e _s	f ₀	D ₀ ²	H ₃	
SRN 55C SRN 55GC	63	140	185	116	95	70	M14	12.5	129	18.2	18	53	8	16	B-PT1/8	10	9.8	5.2	10	
SRN 55LC SRN 55GLC	63	140	235	116	95	70	M14	12.5	179.2	18.2	18	53	8	16	B-PT1/8	10	9.8	5.2	10	
SRN 55SLC SRN 55GSLC	63	140	292	116	150	—	M14	12.5	236.2	18.2	18	53	8	16	B-PT1/8	10	9.8	5.2	10	
SRN 65C SRN 65GC	75	170	244.9	142	110	82	M16	14.5	171.7	21.2	20	65	14	16	B-PT1/8	9	13	5.2	10	
SRN 65LC SRN 65GLC	75	170	303	142	110	82	M16	14.5	229.8	21.2	20	65	14	16	B-PT1/8	9	13	5.2	10	
SRN 65SLC SRN 65GSLC	75	170	380	142	200	—	M16	14.5	306.8	21.2	20	65	14	16	B-PT1/8	9	13	5.2	10	

Model number coding

SRN65 C 2 QZ KK C0 +1270L P Z T - II

Model number	Type of LM block	With QZ lubricator	Contamination protection accessory symbol	LM rail length (in mm)	With plate cover	Symbol for No. of rails used on the same plane
	No. of LM blocks used on the same rail		Radial clearance symbol Normal (No symbol)/Light preload (C1) Medium preload (C0)/Heavy preload (CN1) Super heavy preload (CN2)		Symbol for LM rail jointed use	
				Accuracy symbol High accuracy grade (H)/Precision grade (P) Super precision grade (SP)/Ultra precision grade (UP)		

Notes: This model number indicates that a single-rail unit constitutes one set (i.e., required number of sets when 2 rails are used in parallel is 2 at a minimum).

Grease nipples are not installed when there is a QZ Lubricator. Contact THK if you want to use a grease nipple for a model with a QZ. See **A1-547** for contamination protection accessories, see **A1-75** for radial clearance symbol, See **A1-79** for accuracy symbol. See **A1-13** for symbol for number of rails used on the same plane.

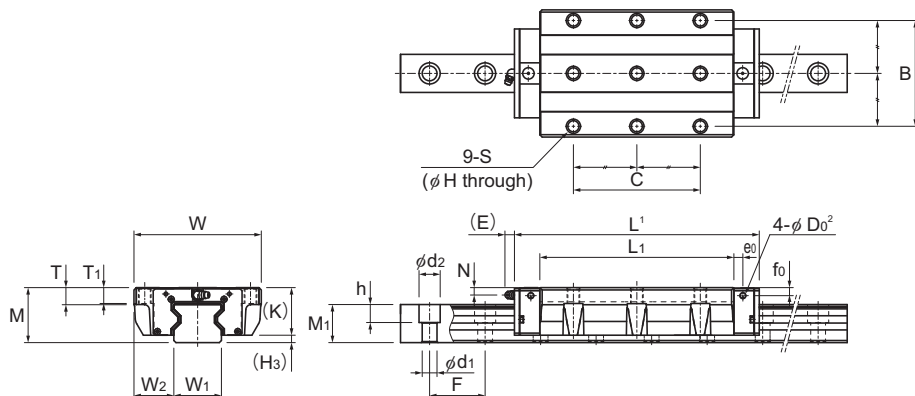

Models SRN55 and 65 SLC

Unit: mm

LM rail dimensions						Basic load rating ¹		Static permissible moment kN·m ³					Mass	
Width W ₁ 0 -0.05	Height W ₂	Pitch M ₁	Pitch F	d ₁ × d ₂ × h	Length ³ Max	C kN	C ₀ kN	M _A		M _B		M _C	LM block kg	LM rail kg/m
								1 block	2 blocks	1 block	2 blocks	1 block		
53	43.5	43	60	16 × 23 × 20	3060	131	266	5.82	33	5.82	33	8.19	5.1	15.8
						125	300	6.5	37.2	6.5	37.2	9.55		
53	43.5	43	60	16 × 23 × 20	3060	167	366	10.8	57	10.8	57	11.2	7.1	15.8
						160	411	12.1	64	12.1	64	13.1		
53	43.5	43	60	16 × 23 × 20	3060	210	488	19.1	93.7	19.1	93.7	15.6	9.4	15.8
						199	544	21	104	21	104	17.3		
63	53.5	49	75	18 × 26 × 22	3000	219	441	12.5	72.8	12.5	72.8	16.8	10.4	21.3
						214	511	14.8	83.8	14.8	83.8	19.4		
63	53.5	49	75	18 × 26 × 22	3000	278	599	22.7	120	22.7	120	22.1	13.9	21.3
						264	670	25.3	135	25.3	135	25.5		
63	53.5	49	75	18 × 26 × 22	3000	352	811	41.3	202	41.3	202	30.9	18.5	21.3
						332	899	45.2	224	45.2	224	25.6		

¹ Length L shown in the table is the length with the contamination protection accessories, code UU or SS.

If other contamination protection accessories or lubricant equipment are installed, the total block length will increase. (See [A1-521](#) or [A1-543](#))

² D₀ are the pilot holes for when a grease nipple is desired for a product with LaCS or a QZ Lubricator.

Pilot holes are not drilled through for models other than those stated above.

For grease nipple mount machining, contact THK.

³ The maximum length indicates the standard maximum length of an LM rail. (See [A1-456](#).)

⁴ The basic dynamic load rating of the roller guide is a value based on a nominal life of 100 km.

The conversion to basic dynamic load rating for a nominal life of 50 km can be obtained from the following equation.

$$C_{50} = C \times 1.23$$

C₅₀ : The basic dynamic load rating for a nominal load of 50 km

C : The basic dynamic load rating in the dimensional table

⁵ Static permissible moment

1 block: the static permissible moment with one LM block

2 blocks: the static permissible moment with two LM blocks in close contact with each other

Notes: The SRN-G is a cageless, Full-Roller type.

For oil lubrication, be certain to let THK know the mounting orientation and where the LM block piping joint should be attached.

(Mounting orientation: see [A1-12](#), Lubricant: see [A24-2](#))

The removing/mounting jig is not provided as standard. To obtain one, please contact THK.

Models SRN-R, SRN-LR, and SRN-SLR

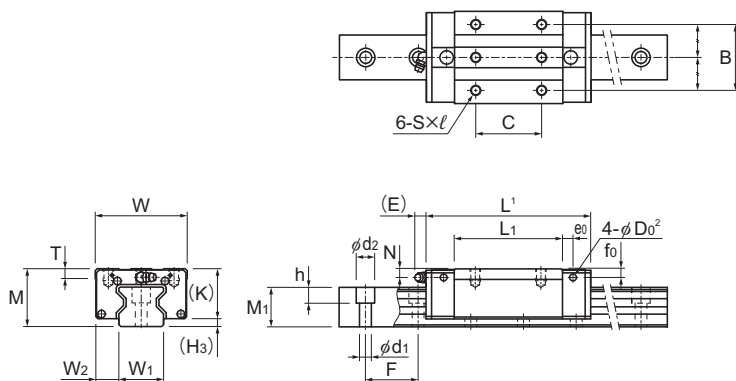

Models SRN35 and 45 R/LR

Model No.	Outer dimensions			LM block dimensions										Pilot hole for side nipple			
	Height M	Width W	Length L	B	C	S × l	L ₁	T	K	N	E	Grease nipple B-M6F	e ₀	f ₀	D ₀ ²	H ₃	
SRN 35R SRN 35GR	44	70	125	50	50	M8 × 9	82.2	10.8	38	6.5	12	B-M6F	8	7	5.2	6	
SRN 35LR SRN 35GLR	44	70	155	50	72	M8 × 9	112.2	10.8	38	6.5	12	B-M6F	8	7	5.2	6	
SRN 35SLR SRN 35GSLR	44	70	180.8	50	100	M8 × 9	138	10.8	38	6.5	12	B-M6F	8	7	5.2	6	
SRN 45R SRN 45GR	52	86	155	60	60	M10 × 11	107	10.8	45	7	12	B-M6F	8.5	7.6	5.2	7	
SRN 45LR SRN 45GLR	52	86	190	60	80	M10 × 11	142	10.8	45	7	12	B-M6F	8.5	7.6	5.2	7	
SRN 45SLR SRN 45GSLR	52	86	231.5	60	120	M10 × 11	183.5	10.8	45	7	12	B-M6F	8.5	7.6	5.2	7	

Model number coding

SRN45 LR 2 QZ KK C0 +1200L P Z T - II

Model number

Type of LM block

With QZ lubricator

Contamination protection accessory symbol

LM rail length (in mm)

With plate cover

Symbol for No. of rails used on the same plane

No. of LM blocks used on the same rail

Radial clearance symbol
Normal (No symbol)
Light preload (C1)
Medium preload (C0)

Accuracy symbol
High accuracy grade (H)/Precision grade (P)/Super precision grade (SP)
Ultra precision grade (UP)

Symbol for LM rail jointed use

Notes: This model number indicates that a single-rail unit constitutes one set (i.e., required number of sets when 2 rails are used in parallel is 2 at a minimum).

Grease nipples are not installed when there is a QZ Lubricator. Contact THK if you want to use a grease nipple for a model with a QZ. See **A1-547** for contamination protection accessories, see **A1-75** for radial clearance symbol, See **A1-79** for accuracy symbol. See **A1-13** for symbol for number of rails used on the same plane.

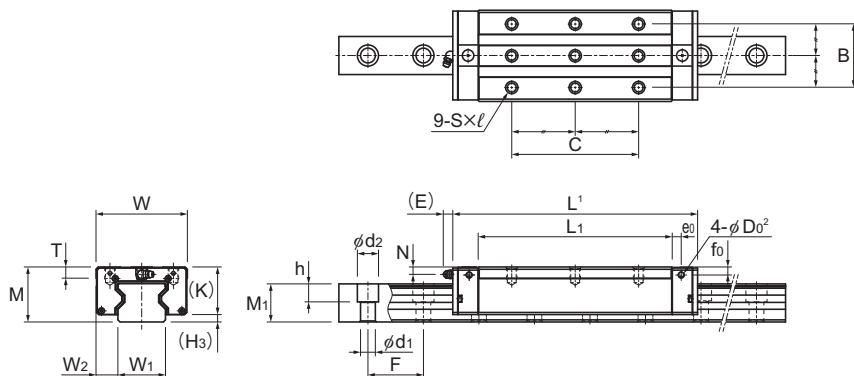

Models SRN35 and 45 SLR

Unit: mm

LM rail dimensions						Basic load rating ¹		Static permissible moment kN·m ⁵					Mass	
Width W ₁ 0 -0.05	W ₂	Height M ₁	Pitch F	d ₁ × d ₂ × h	Length ³ Max	C kN	C ₀ kN	M _A		M _B		M _C	LM block kg	LM rail kg/m
								1 block	2 blocks	1 block	2 blocks	1 block		
34	18	30	40	9 × 14 × 12	3000	59.1	119	1.66	10.1	1.66	10.1	2.39	1.1	6.9
						55.3	131	1.77	11.1	1.77	11.1	2.69		
34	18	30	40	9 × 14 × 12	3000	76	165	3.13	17	3.13	17	3.31	1.5	6.9
						71.4	182	3.39	18.8	3.39	18.8	3.74		
34	18	30	40	9 × 14 × 12	3000	87.9	199	4.53	23.9	4.53	23.9	4.09	1.8	6.9
						83.4	222	5	26.6	5	26.6	4.56		
45	20.5	36	52.5	14 × 20 × 17	3090	91.9	192	3.49	20	3.49	20	4.98	2	11.3
						87.8	216	3.9	22.5	3.9	22.5	5.87		
45	20.5	36	52.5	14 × 20 × 17	3090	115	256	6.13	32.2	6.13	32.2	6.64	2.6	11.3
						110	288	6.87	36.3	6.87	36.3	7.83		
45	20.5	36	52.5	14 × 20 × 17	3090	139	328	9.99	50	9.99	50	8.91	3.4	11.3
						133	368	11.1	56	11.1	56	10		

¹ Length L shown in the table is the length with the contamination protection accessories, code UU or SS.

If other contamination protection accessories or lubricant equipment are installed, the total block length will increase. (See [A1-521](#) or [A1-543](#))

² D₀ are the pilot holes for when a grease nipple is desired for a product with LaCS or a QZ Lubricator.

Pilot holes are not drilled through for models other than those stated above.

For grease nipple mount machining, contact THK.

³ The maximum length indicates the standard maximum length of an LM rail. (See [A1-456](#).)

⁴ The basic dynamic load rating of the roller guide is a value based on a nominal life of 100 km.

The conversion to basic dynamic load rating for a nominal life of 50 km can be obtained from the following equation.

$$C_{50} = C \times 1.23$$

C₅₀ : The basic dynamic load rating for a nominal load of 50 km

C : The basic dynamic load rating in the dimensional table

⁵ Static permissible moment

1 block: the static permissible moment with one LM block

2 blocks: the static permissible moment with two LM blocks in close contact with each other

Notes: The SRN-G is a cageless, Full-Roller type.

For oil lubrication, be certain to let THK know the mounting orientation and where the LM block piping joint should be attached.

(Mounting orientation: see [A1-12](#), Lubricant: see [A24-2](#))

The removing/mounting jig is not provided as standard. To obtain one, please contact THK.

Models SRN-R, SRN-LR, and SRN-SLR

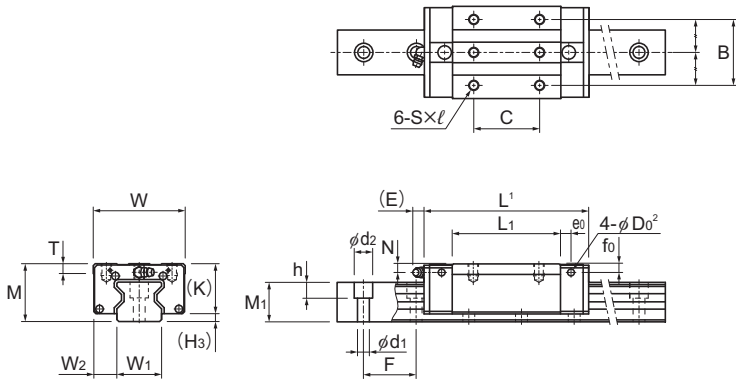

Models SRN55 and 65 R/LR

Model No.	Outer dimensions			LM block dimensions										Pilot hole for side nipple			
	Height M	Width W	Length L	B	C	S × l	L ₁	T	K	N	E	Grease nipple	e ₀	f ₀	D ₀ ²	H ₃	
SRN 55R SRN 55GR	63	100	185	75	75	M12×13	129	13.8	53	8	16	B-PT1/8	10	9.8	5.2	10	
SRN 55LR SRN 55GLR	63	100	235	75	95	M12×13	179.2	13.8	53	8	16	B-PT1/8	10	9.8	5.2	10	
SRN 55SLR SRN 55GSLR	63	100	292	75	150	M12×13	236.2	13.8	53	8	16	B-PT1/8	10	9.8	5.2	10	
SRN 65R SRN 65GR	75	126	244.9	76	70	M16×16	171.7	19.5	65	14	16	B-PT1/8	9	13	5.2	10	
SRN 65LR SRN 65GLR	75	126	303	76	120	M16×16	229.8	19.5	65	14	16	B-PT1/8	9	13	5.2	10	
SRN 65SLR SRN 65GSLR	75	126	380	76	200	M16×16	306.8	19.5	65	14	16	B-PT1/8	9	13	5.2	10	

Model number coding

SRN65 LR 2 QZ KK C0 +1270L P Z T - II

Model number

Type of LM block

With QZ lubricator

Contamination protection accessory symbol

LM rail length (in mm)

With plate cover

Symbol for No. of rails used on the same plane

No. of LM blocks used on the same rail

Radial clearance symbol
Normal (No symbol)
Light preload (C1)
Medium preload (C0)

Accuracy symbol
High accuracy grade (H)/Precision grade (P)/Super precision grade (SP)
Ultra precision grade (UP)

Symbol for LM rail jointed use

Notes: This model number indicates that a single-rail unit constitutes one set (i.e., required number of sets when 2 rails are used in parallel is 2 at a minimum).

Grease nipples are not installed when there is a QZ Lubricator. Contact THK if you want to use a grease nipple for a model with a QZ. See **A1-547** for contamination protection accessories, see **A1-75** for radial clearance symbol, See **A1-79** for accuracy symbol. See **A1-13** for symbol for number of rails used on the same plane.

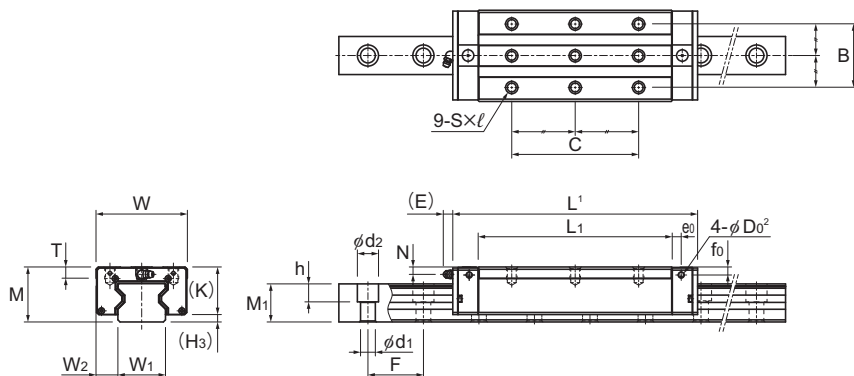

Models SRN55 and 65 SLR

Unit: mm

LM rail dimensions						Basic load rating ¹		Static permissible moment kN·m ⁵					Mass	
Width W ₁ 0 -0.05	W ₂	Height M ₁	Pitch F	d ₁ × d ₂ × h	Length ³ Max	C	C ₀	M _A		M _B		M _C	LM block kg	LM rail kg/m
								1 block	2 blocks	1 block	2 blocks	1 block		
53	23.5	43	60	16 × 23 × 20	3060	131	266	5.82	33	5.82	33	8.19	3.3	15.8
						125	300	6.5	37.2	6.5	37.2	9.55		
53	23.5	43	60	16 × 23 × 20	3060	167	366	10.8	57	10.8	57	11.2	4.6	15.8
						160	411	12.1	64	12.1	64	13.1		
53	23.5	43	60	16 × 23 × 20	3060	210	488	19.1	93.7	19.1	93.7	15.6	5	15.8
						199	544	21	104	21	104	17.3		
63	31.5	49	75	18 × 26 × 22	3000	219	441	12.5	72.8	12.5	72.8	16.8	7.1	21.3
						214	511	14.8	83.8	14.8	83.8	19.4		
63	31.5	49	75	18 × 26 × 22	3000	278	599	22.7	120	22.7	120	22.1	9.4	21.3
						264	670	25.3	135	25.3	135	25.5		
63	31.5	49	75	18 × 26 × 22	3000	352	811	41.3	202	41.3	202	30.9	12.6	21.3
						332	899	45.2	224	45.2	224	25.6		

¹ Length L shown in the table is the length with the contamination protection accessories, code UU or SS.

If other contamination protection accessories or lubricant equipment are installed, the total block length will increase. (See [A1-521](#) or [A1-543](#))

² D₀ are the pilot holes for when a grease nipple is desired for a product with LaCS or a QZ Lubricator.

Pilot holes are not drilled through for models other than those stated above.

For grease nipple mount machining, contact THK.

³ The maximum length indicates the standard maximum length of an LM rail. (See [A1-456](#).)

⁴ The basic dynamic load rating of the roller guide is a value based on a nominal life of 100 km.

The conversion to basic dynamic load rating for a nominal life of 50 km can be obtained from the following equation.

$$C_{50} = C \times 1.23$$

C₅₀ : The basic dynamic load rating for a nominal load of 50 km

C : The basic dynamic load rating in the dimensional table

⁵ Static permissible moment

1 block: the static permissible moment with one LM block

2 blocks: the static permissible moment with two LM blocks in close contact with each other

Notes: The SRN-G is a cageless, Full-Roller type.

For oil lubrication, be certain to let THK know the mounting orientation and where the LM block piping joint should be attached.

(Mounting orientation: see [A1-12](#), Lubricant: see [A24-2](#))

The removing/mounting jig is not provided as standard. To obtain one, please contact THK.

Standard Lengths and Maximum Lengths of LM Rails

Table 4 shows the standard lengths and the maximum lengths of model SRN variations. If the maximum length of the desired LM rail exceeds these values, jointed rails will be used. Contact THK for details.

For special rail lengths, it is recommended to use a value corresponding to the G and g dimensions from the table. As the G and g dimensions increase, this portion becomes less stable, and the accuracy performance is severely impacted.

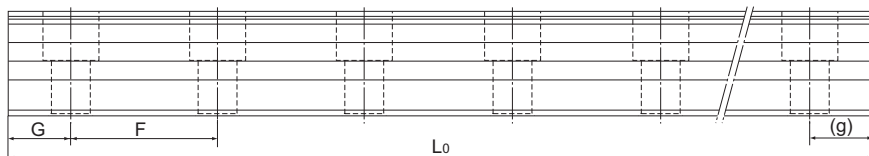

Table 4: Standard Lengths and Maximum Lengths of Model SRN LM Rails

Unit: mm

Model No.	SRN 35	SRN 45	SRN 55	SRN 65
LM rail standard lengths (L_0)	280	570	780	1270
	360	675	900	1570
	440	780	1020	2020
	520	885	1140	2620
	600	990	1260	
	680	1095	1380	
	760	1200	1500	
	840	1305	1620	
	920	1410	1740	
	1000	1515	1860	
	1080	1620	1980	
	1160	1725	2100	
	1240	1830	2220	
	1320	1935	2340	
	1400	2040	2460	
	1480	2145	2580	
	1560	2250	2700	
	1640	2355	2820	
	1720	2460	2940	
	1800	2565	3060	
	1880	2670		
	1960	2775		
	2040	2880		
	2200	2985		
	2360	3090		
2520				
2680				
2840				
3000				
Standard pitch F	40	52.5	60	75
G, g	20	22.5	30	35
Max length	3000	3090	3060	3000

Notes: The maximum length varies with accuracy grades. Contact THK for details.

If jointed rails are not allowed and a greater length than the maximum values above is required, contact THK.

Plate Cover

By covering the LM rail's mounting holes with ultra-thin stainless steel (SUS304) plates, the effectiveness of the end seals increases drastically, helping prevent foreign materials and liquid from entering from the top of the LM rail. Contact THK for further details regarding mounting.

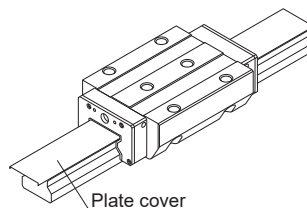

Notes: The Model SRN with plate cover is not a standard specification. (Please note it is not possible to add just the plate cover afterwards.)
The LM block must be removed from the LM rail when mounting. When doing this, a removing/mounting jig (see **A1-575**) is required. Please contact THK for details.
Plate covers are available for models SRN 35 to 65.

Lubrication Hole

Lubrication Hole for Model SRN

Model SRN allows lubrication from both the side and top faces of the LM block. The lubrication hole of standard types is not drilled through in order to prevent foreign material from entering the LM block. When using the lubrication hole, contact THK.

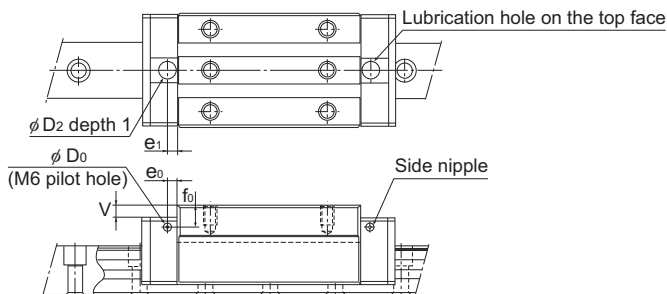

Unit: mm

Model No.	Pilot hole for side nipple			Applicable nipple	Lubrication hole on the top face				
	e_0	f_0	D_0		D_2	(O-ring)	V	e_1	
SRN	35C 35LC 35SLC	8	7.0	5.2	M6F	10.2	(P7)	0.4	6
	35R 35LR 35SLR	8	7.0	5.2	M6F	10.2	(P7)	0.4	6
	45C 45LC 45SLC	8.5	7.6	5.2	M6F	10.2	(P7)	0.4	7
	45R 45LR 45SLR	8.5	7.6	5.2	M6F	10.2	(P7)	0.4	7
	55C 55LC 55SLC	10	9.8	5.2	M6F	10.2	(P7)	0.4	11
	55R 55LR 55SLR	10	9.8	5.2	M6F	10.2	(P7)	0.4	11
	65C 65LC 65SLC	9	13	5.2	M6F	10.2	(P7)	0.4	10
	65R 65LR 65SLR	9	13	5.2	M6F	10.2	(P7)	0.4	10

Note: Upper surface lubrication is oil lubrication only. Contact THK if you are considering using the lubrication hole on the top face for grease lubrication.