



Caged Ball LM Guide Actuator **SKR**



Modularized to reduce work hours
and make moving parts more compact.
Long service life and long-term maintenance-free operation.

Global Standard

SKR

Caged Ball LM Guide Actuator

THK has sold LM Guide actuators for use in various applications for over 20 years in more than 40 countries worldwide.

The SKR is a high-performance device that is modularized to reduce work hours and make moving parts more compact than ever before.

A consistent seller and global standard actuator, it continues to help customers solve problems in a wide variety of fields, such as transport, inspection, and assembly.





The many advantages of

Feature 1

Compact Structure (Combined Modules)

SKR actuators have a structure embedding an inner block, which consists of an LM block and ball screw nut, in an outer rail with a U-shaped cross-section. They have achieved significant miniaturization compared to conventional products. They can easily be combined with other devices, which further contributes to miniaturization of those devices.

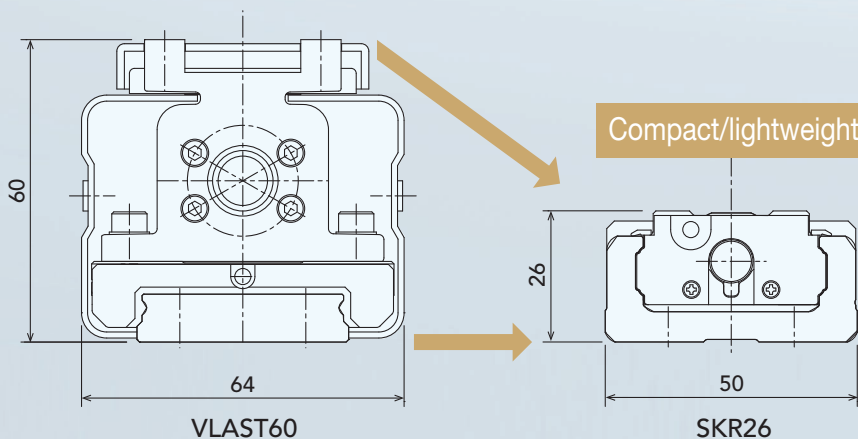

Sectional dimensions

66%

Mass

31%
reduction!

Feature 2

High-Rigidity Structure (Outer Rail with a U-Shaped Cross-Section)

Excellent high rigidity is achieved by using an outer rail with a U-shaped cross-section to create a structure resilient against torsion, bending, and deflection that enables a larger moment to be received. It is also suitable for applications with long overhangs such as the top axis of XY axes.

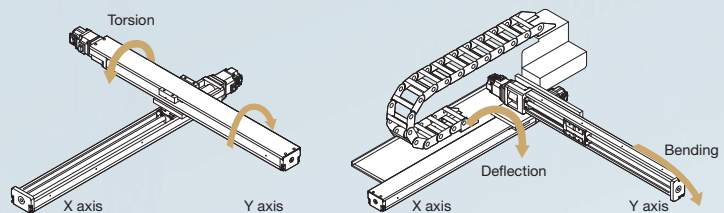

Geometric moment of inertia around the Y axis

Approx. 2.8x

Geometric moment of inertia around the X axis

Approx. 5.7x

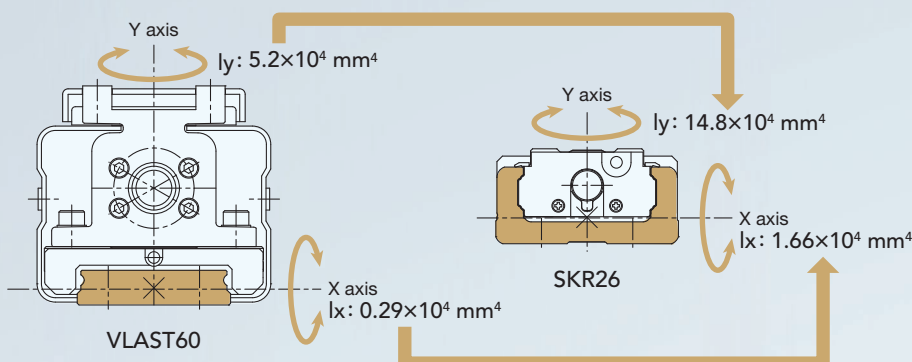

THK's original structure

Feature 3

Can Be Used in Any Orientation (Same Rated Load in 4 Directions)

Each row of balls in the linear guide is arranged at a 45° contact angle, achieving the same rated load performance for each of the 4 directions (radial, reverse-radial, and horizontal directions) acting on the inner block. It can be used in any orientation.

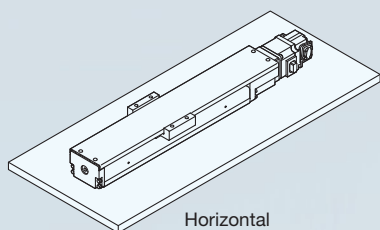
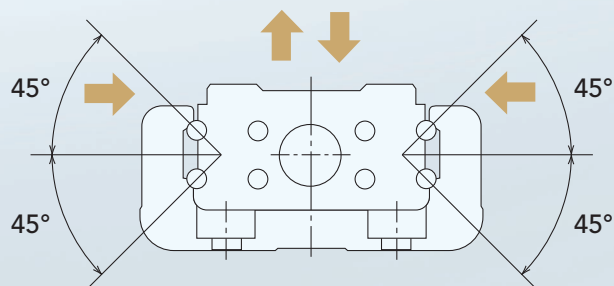

Horizontal

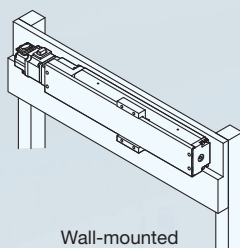

Wall-mounted

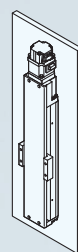

Vertical

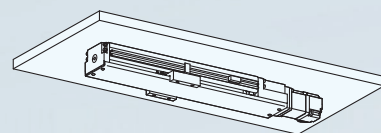

Hanging (upside-down)

Feature 4

High Precision

The linear motion guide is a clearance-free, highly rigid guide that features four rows of circular arc grooves with a two-point contact structure, which allows light movement even when a preload is applied. In addition, it enables high-precision feeding by minimizing changes in friction resistance caused by varying loads. It achieves precision-grade positioning for all types of devices, contributing to improved high-precision and high-quality performance.

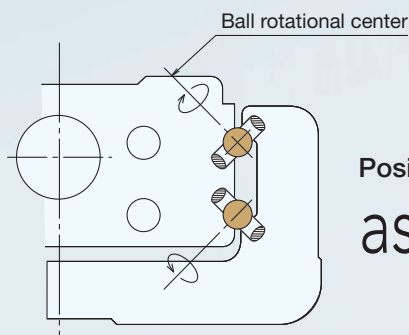

Positioning repeatability

as precise as ± 0.003 mm!!
(Precision Grade)

Modular structure with integrated

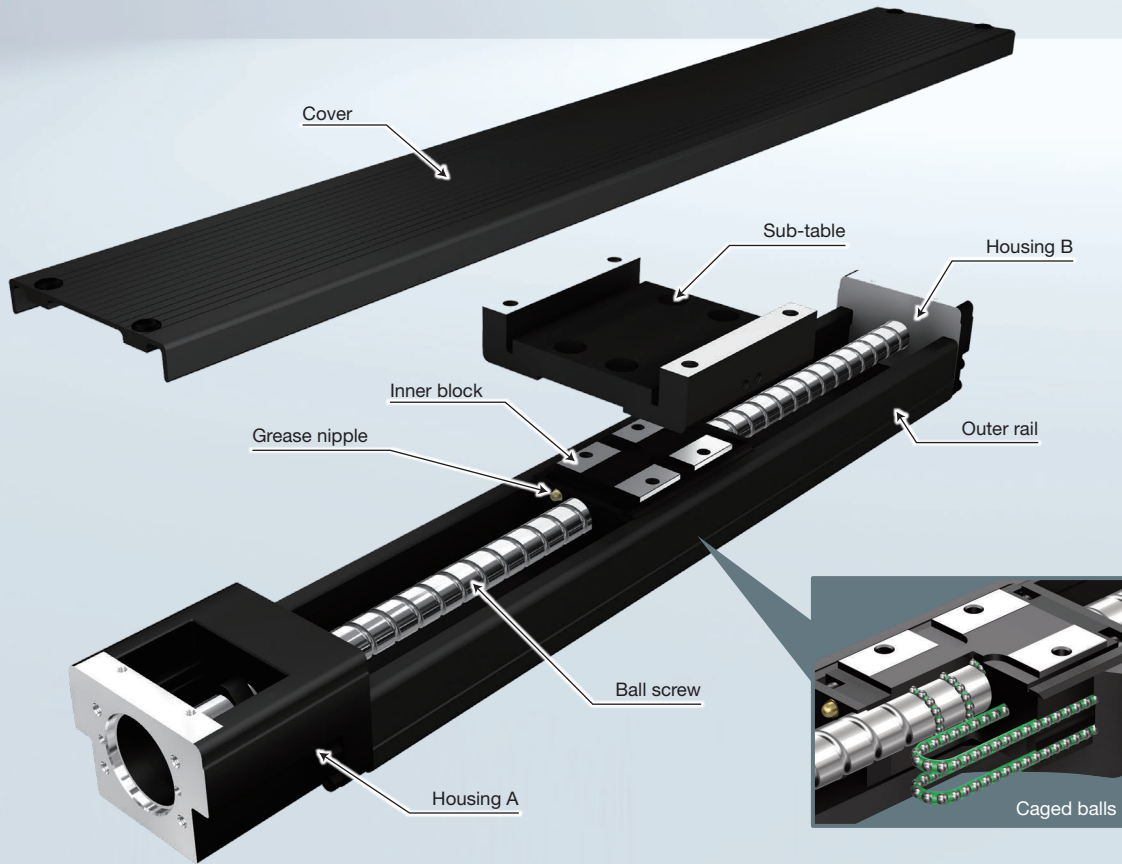

Select the Optimal Model

A lineup of different shapes and sizes with 4 types of blocks and motor mounting specifications (direct coupling or motor wrap) enables selection to suit the application.

Size Lineup

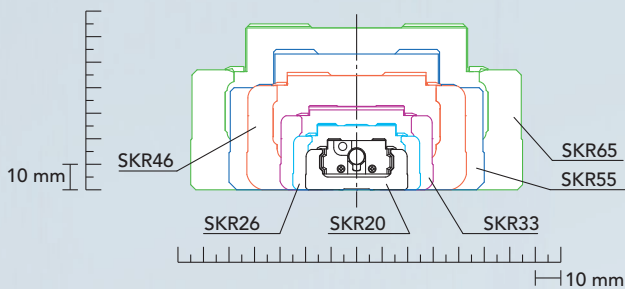

Block Types

<p>A type</p> <p>Typical block type.</p>	<p>B type</p> <p>Shape using 2 A type inner blocks to achieve high rigidity and high load capacity.</p>	<p>C type</p> <p>Shorter overall length than the A type inner block as an extended stroke type. Note: SKR3306, 3310, 4610, and 4620 only.</p>	<p>D type</p> <p>Shape using 2 C type inner blocks to achieve high rigidity and high load capacity. Note: SKR3306, 3310, 4610, and 4620 only.</p>
---	--	--	--

Shape Lineup

<p>Direct motor coupling (without cover)</p>	<p>Motor wrap (without cover)</p>	<p>Direct motor coupling (with cover)</p>	<p>Motor wrap (with cover)</p>
--	---------------------------------------	---	------------------------------------

LM Guide and ball screw

THK Technology

Caged Ball Technology

In the caged ball structure, balls are retained by a ball cage as they recirculate. This eliminates friction between balls and keeps them arranged uniformly as they move. Also, the spaces between the ball circulation parts and the ball cages (grease pockets) are filled with grease that covers the contact surfaces of the balls and ball cages as the balls rotate, allowing an oil film to continuously form on the surfaces of the balls. This makes it less likely that the oil film will break. The SKR also provides the following advantages.

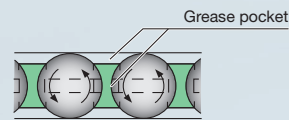
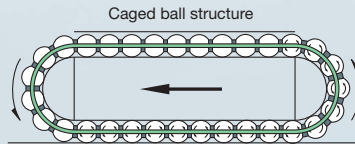

Long Service Life

The SKR's functions have been further enhanced compared to the KR type. The basic dynamic load rating of the LM Guide and ball screw portion has been increased, and an even longer service life has been achieved.

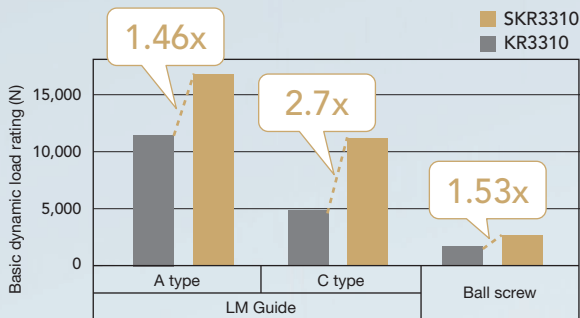

SKR and KR basic dynamic load rating comparison

Exceptional Sliding Performance

The Caged Ball SKR type suppresses torque fluctuations.

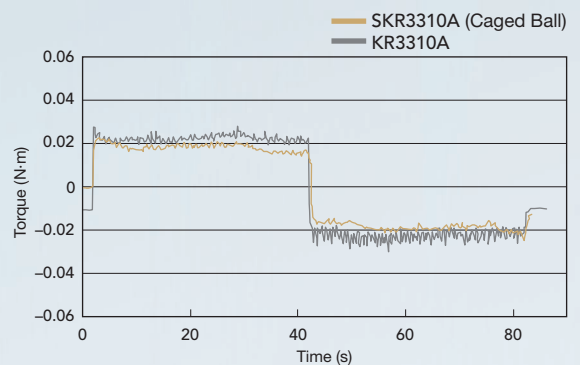

SKR and KR torque fluctuation comparison

Maintenance-Free

Grease is held within the ball cage, achieving long-term maintenance-free operation.

Note: For SKR20/26, caged balls are adopted only for the LM Guide, while the ball screw portion is equipped with a QZ Lubricator.

High-Speed Performance

Supports high rotation speeds of 6,000 min⁻¹.* The high-lead type lineup has been increased with the addition of SKR33/55/65.

*Excludes some models.

Model	Lead	
	SKR	KR
33	6, 10, 20	6, 10
55	20, 30 , 40	20
65	20 , 25, 30 , 50	25

Unit: mm

Low Noise/Acceptable Running Sound

Noise from impacts between balls is eliminated, achieving low noise and acceptable running sound even at high speeds.

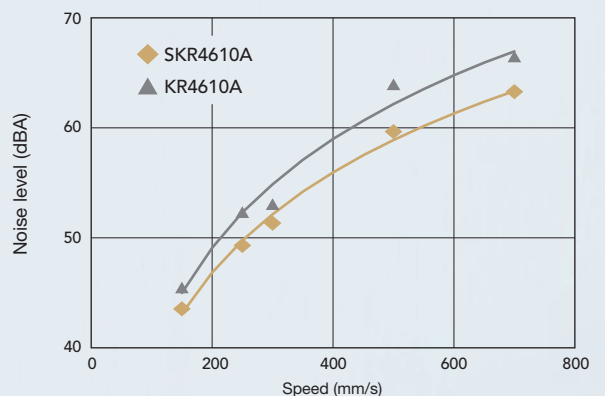

SKR and KR torque noise comparison



Automotive industry
Inter-Process Conveyance System

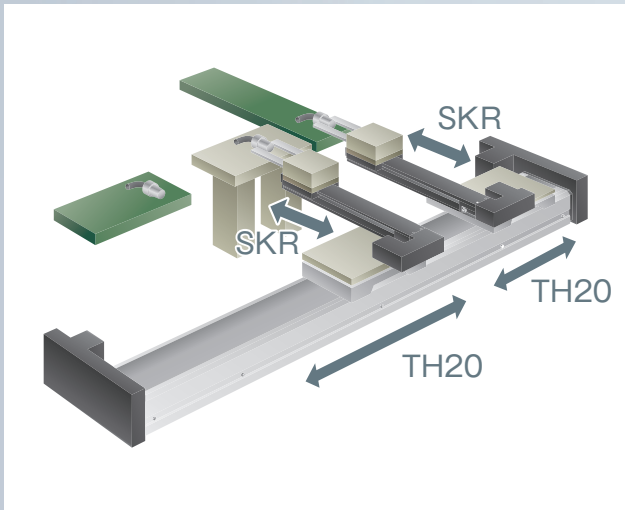

The SKR is used for the upper axis of automotive component transfer units, while custom TH units are used for the lower axis. When used to replace conventional rack & pinion drives, these two products allow for a more compact installation space and enable operations with faster cycle times.

Models used
Upper axis: SKR3320A wrap
Lower axis: Special TH20

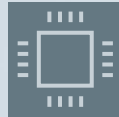

Electronic components industry
PCB Mounting Device

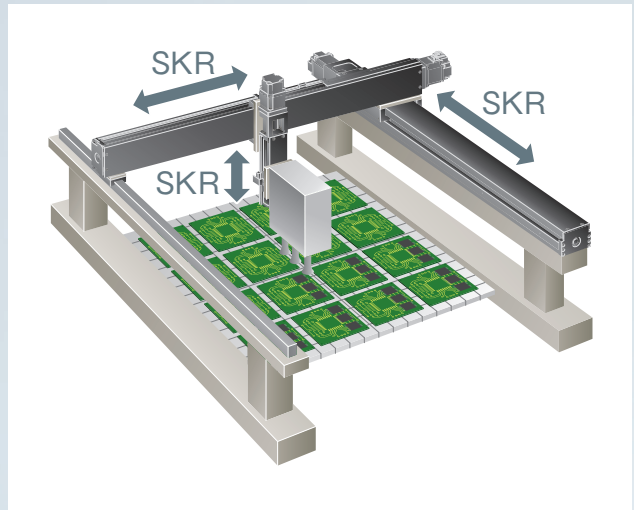

The SKR is used in the moving parts of board mounting devices. The high-lead ball screw provides excellent high-speed performance and accurately positions circuit boards, providing high rigidity for dramatically improved mounting precision.

Models used
X axis: SKR5540
Y axis: SKR4620
Z axis: SKR2606

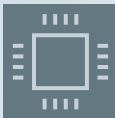

Electronic components industry
Push Button Inspection Equipment

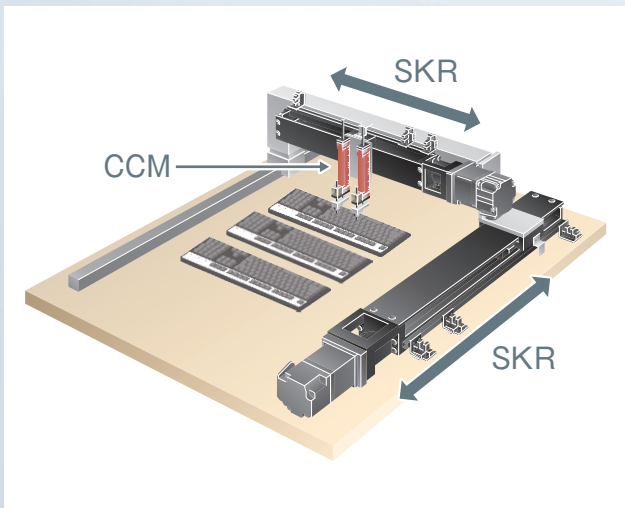

The SKR and CCM are used in inspection equipment. Replacing the air cylinder on the Z axis with a linear motor allows for all axes to be motorized, and the high accuracy and high speed provided by the SKR enables operations with fast cycle times while offering greater position accuracy.

Models used
X axis: SKR3310A
Y axis: SKR2606A
Z axis: CCM05

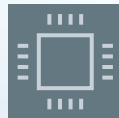

Electronic components industry
Sealing Equipment

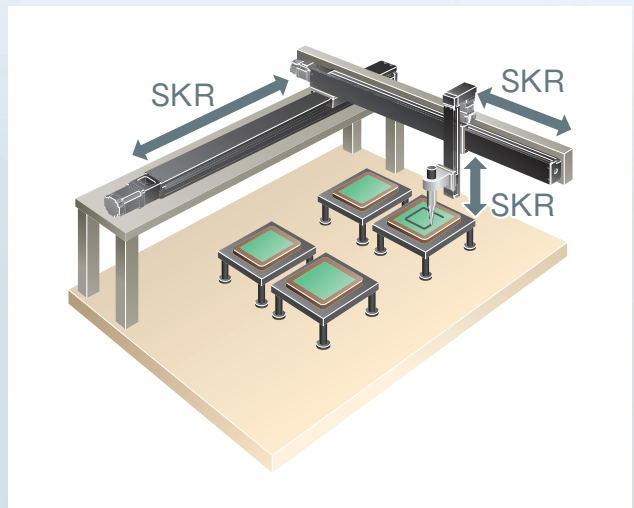

The SKR is used for the moving nozzle section of sealing equipment. The SKR has excellent rigidity to suppress vibrations at the overhang and nozzle tip, contributing to improved productivity.

Models used
X axis: SKR5530
Y axis: SKR3320
Z axis: SKR2006



Pharmaceuticals/food industry
Printing Device

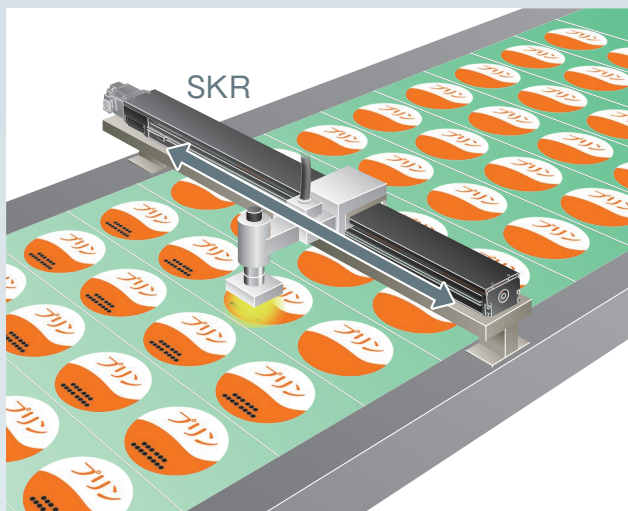

The SKR is used in the device that prints the date onto cup seals. The production quantity per day is large, but daily production capacity increased by 2.5 times compared to conventional air cylinders by replacing them with the SKR.

Model used SKR4620



Machine tool industry
Pallet Changer

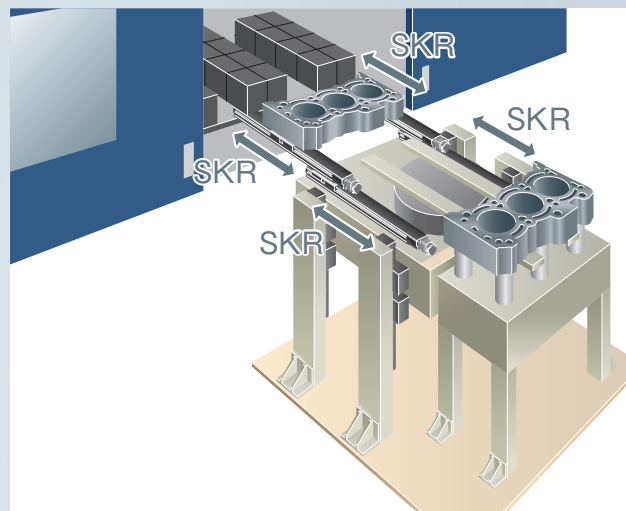

Two 2-block SKRs are stacked in the changer. A high rigidity SKR unit is used to carry the load of the large overhang. This also takes up less space than conventional multi-jointed robots.

Models used Lower axis: SKR4620B
Upper axis: SKR4620B



Machine tool industry
Workpiece Inserter

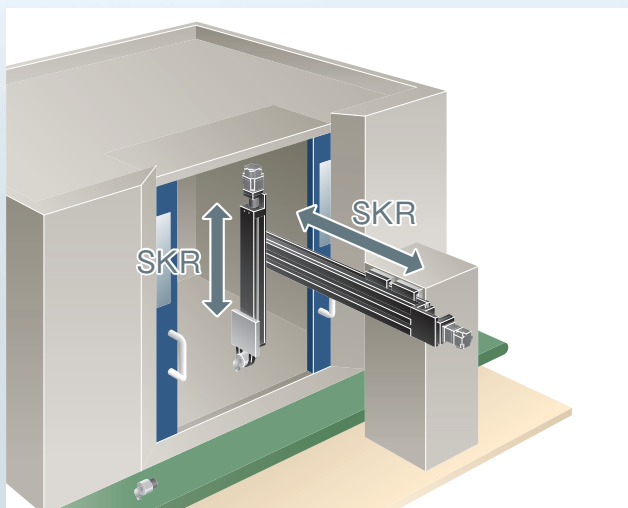

The SKR is used in the workpiece inserter axis. The SKR outer rail can move to insert items into the opening/closing part. The SKR has high rigidity to support large loads.

Models used Horizontal axis: SKR4620A
Lifting axis: SKR3310B



Machine tool industry
Loader for Automated Lathes

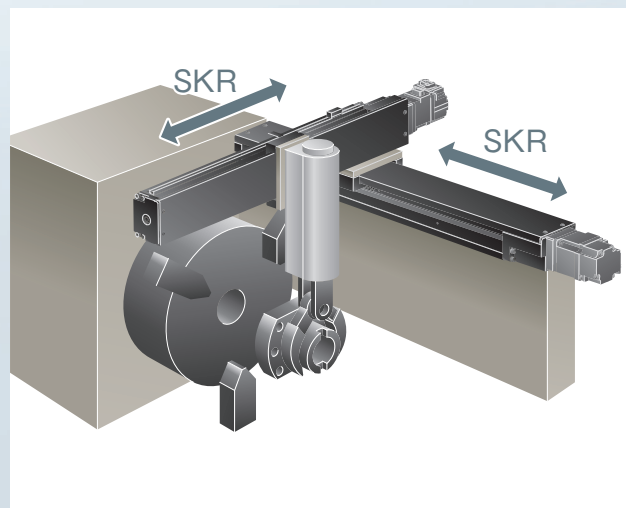

The SKR is used in the workpiece travel part. The SKR is used with a cover, as it is installed so close to the machining area that it is exposed to cutting dust. It achieves a compact size through modularization, and its high rigidity enables accurate positioning.

Models used Lower axis: SKR3310
Upper axis: SKR3310

Series Overview

Model	Ball screw lead (mm)	Stroke ¹ (mm)	Estimated motor capacity (W)	Maximum load capacity ^{2,3} (kg)		
				Horizontal	Wall-mounted	Vertical
SKR20	1	30 to 130	50	12.5	10	3
	6			12.5	10	6
SKR26	2	60 to 210	50	27.5	22	14
	6			27.5	22	7
SKR33	6	45 to 595	100	43.5	35	19
	10			34.5	30	12 (11.5)
	20			21 (18.5)	21 (18.5)	6 (5.5)
SKR46	10	190 to 790	200	77	77	18 (16)
	20			42 (31)	42 (31)	8
	10		400	96	77	23 (16)
	20			90 (75)	57.5	18 (16.5)
SKR55	20	800 to 1,200	400	66	66	17
	30			27	27	9
	40			13	13	5
	20		750	118	90	37 (31.5)
	30			80	79.5	23
	40			43	43	15
SKR65	20	790 to 1,490	750	147	133.5	29
	25			93	93	24
	30			62	62	19
	50			18	18	7

¹ The stroke is the value with 1 block (A type: without QZ).

² The maximum load capacity refers to the mass at the below speed and acceleration/deceleration.

Speed: Rated rotational speed of the motor (3,000 min⁻¹)

Acceleration and deceleration: Less than 10 mm lead: 0.15 G, 10 mm lead: 0.3 G, 20 mm lead: 0.5 G (0.3 G for SKR6550)

³ The value in parentheses is with motor wrap specifications.

⁴ The maximum speed is restricted by the permissible speed of the actuator.

It is also the speed when 1 block (A type: without QZ) and normal accuracy grade are selected.

Model Number Coding

Model ①	Ball screw lead ②	Block type ③	QZ specification ④	Stroke ⑤
SKR46	10	A	QZA	0675
SKR20	01: 1 mm	A: x1	No symbol: Without QZ	0020: 20 mm
SKR26	02: 2 mm	B: x2	QZ	0030: 30 mm
SKR33	06: 6 mm	C: x1	QZA	0035: 35 mm
SKR46	10: 10 mm	D: x2	QZB	0060: 60 mm
SKR55	20: 20 mm		QZAD	0110: 110 mm
SKR65	25: 25 mm			0550: 550 mm
	30: 30 mm			0590: 590 mm
	40: 40 mm			to
	50: 50 mm			1490: 1,490 mm

The available ball screw lead options vary based on the model.
 SKR20: "01," "06"
 SKR26: "02," "06"
 SKR33: "06," "10," "20"
 (20 mm is block type A and B only)
 SKR46: "10," "20"
 SKR55: "20," "30," "40"
 SKR65: "20," "25," "30," "50"

The following models allow selection of ④ QZ specifications.
 SKR33 → p. 35
 SKR46 → p. 59
 * Selection is not possible for SKR20, SKR26, SKR55, and SKR65.

If "QZ," "QZA," "QZB," or "QZAD" is selected for ④ QZ specification, specify the stroke with QZ.
 SKR33 → p. 53 to p. 58
 SKR46 → p. 77 to p. 82
 If 2: With bellows is selected for ⑧ Cover, specify the stroke with bellows.
 → p. 109 to p. 112

	Maximum speed for each stroke ⁴ (mm/s)															Product page
	Stroke ¹ (mm)															
	100	200	300	400	500	600	700	800	900	1,000	1,100	1,200	1,300	1,400	1,500	
100																p. 11
600																
200																p. 23
600																
	600			550	390											p. 35
	1,000			920	650											
	2,000			1,780	1,270											
	1,000				730	550	430									p. 59
	2,000			1,980	1,430	1,080	840									
	1,000				730	550	430									
	2,000			1,980	1,430	1,080	840									
		1,100				880	730	610	520							p. 83
		1,650				1,330	1,100	920	780							
		2,160				1,750	1,440	1,210	1,030							
		1,100				880	730	610	520							
		1,650				1,330	1,100	920	780							
		2,160				1,750	1,440	1,210	1,030							
		1,470				970	690	450								p. 97
		1,810				1,200	850	550								
		2,210				1,460	1,030	670								
		3,000				2,350	1,680	1,100								

Accuracy grade ⑥	With/without motor ⑦
P	0
No symbol: Normal grade	With direct coupling
H: High accuracy grade	0: Direct coupling (without motor)
P: Precision grade	1: Direct coupling (THK will purchase and mount the motor you specify.)
	With motor wrap
	R1: Non-standard side wrap (without motor)
	R2: Standard side wrap (without motor)
	R3: Bottom side wrap (without motor)
	R4: Non-standard side wrap (THK will purchase and mount the motor you specify.)
	R5: Standard side wrap (THK will purchase and mount the motor you specify.)
	R6: Bottom side wrap (THK will purchase and mount the motor you specify.)

Cover ⑧	Sensors ⑨	Housing A/Intermediate flange ⑩	
1	2	AV	
0: Without cover	0	With direct coupling	With motor wrap
1: With cover	1	A0	WN - 05D
2: With bellows	2	AN	WP - 08D
	6	AP	WP - 08K
	7	AQ	WP - 08M
	B	AR	WQ - 08D
	E	AS	WQ - 08K
	H	AT	WQ - 08M
	L	AU	WV - 14M
	J	AV	WY - 11M
	M	AY	WY - 14M
		AZ	WZ - 16M
		A5	WZ - 19M
		A6	W5 - 19M
		20	
		30	
		40	
		60	

If "0" is selected:
A coupling is not provided. Indicate when placing an order if a coupling is required.

If "R1," "R2," or "R3" is selected:
A timing pulley and timing belt are provided.

If "1," "R4," "R5," or "R6" is selected:
The specified motor will be installed. Indicate the motor cable direction separately.
Select ⑩ Housing A/Intermediate flange to match the specified motor.

When selecting "QZ," "QZA," "QZB," or "QZAD" for ④ QZ specification, 2: With bellows cannot be selected.

Motors from various manufacturers can be mounted.
Contact THK for details.

SKR20 A/B

Direct motor coupling	Motor wrap	Width 40 mm	Height 20 mm	Max. stroke 130 mm
-----------------------	------------	-------------	--------------	--------------------

Model Number Coding

Model	Ball screw lead	Block type	Stroke	Accuracy grade	With/without motor	Cover	Sensors	Housing A/ Intermediate flange
①	②	③	④	⑤	⑥	⑦	⑧	⑨
SKR20	01	A	0030	P	0	1	2	AQ
SKR20	01: 1 mm 06: 6 mm	A: x1 B: x2	0030: 30 mm to 0130: 130 mm	No symbol: Normal grade H: High accuracy grade P: Precision grade	With direct coupling 0: Direct coupling (without motor) 1: Direct coupling (THK will purchase and mount the motor you specify.) With motor wrap R1: Non-standard side wrap (without motor) R2: Standard side wrap (without motor) R3: Bottom side wrap (without motor) R4: Non-standard side wrap (THK will purchase and mount the motor you specify.) R5: Standard side wrap (THK will purchase and mount the motor you specify.) R6: Bottom side wrap (THK will purchase and mount the motor you specify.)	0: Without cover 1: With cover 2: With bellows	0 1 2 6 7 B E H L J M	With direct coupling A0 AN AP AQ AR AS 20 With motor wrap WN-05D WP-08D WP-08K WQ-08D WQ-08K
			When selecting 2: With bellows for ⑦ Cover, specify the stroke with bellows. → p. 109 to p. 110		When selecting "0": A coupling is not provided. Indicate when placing an order if a coupling is required.		Sensor details → p. 17	
			When selecting "1," "R4," "R5," or "R6": The specified motor will be installed. Indicate the motor cable direction separately. Select ⑨ Intermediate flange to match the specified motor.				With direct coupling → p. 19 With motor wrap → p. 21	

③ Block Type

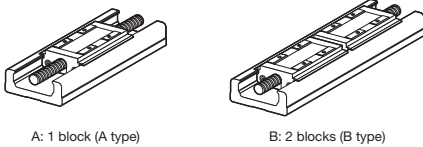

⑥ Motor Mounting Method

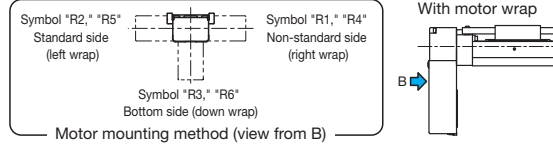

Selection Materials

Basic Specifications

LM Guide	Basic dynamic load rating C (N)		6,010
	Basic static load rating C ₀ (N)		8,030
	Radial clearance (mm)	Normal grade/High accuracy grade (H)	-0.004 to 0
		Precision grade (P)	-0.006 to -0.004
	Geometric moment of inertia	I _x ¹ (mm ⁴)	6 × 10 ⁵
I _y ² (mm ⁴)		6.14 × 10 ⁴	
Mass (kg/m)		2.6	
Ball screw	Ball screw lead (mm)		1 6
	Basic dynamic load rating C _a (N)	Normal grade/High accuracy grade (H)	660 860
		Precision grade (P)	1,060
	Basic static load rating C _{0a} (N)	Normal grade/High accuracy grade (H)	1,170 1,450
		Precision grade (P)	1,600
	Screw shaft diameter (mm)		Ø6
	Thread minor diameter (mm)		Ø5.3 Ø5
	Ball center-to-center diameter (mm)		Ø6.15 Ø6.3
Permissible rotational speed ³ (min ⁻¹)	Normal grade/High accuracy grade (H)	6,000	
	Precision grade (P)		
Bearing (Fixed side)	Axial direction	Basic dynamic load rating C _a (N)	1,150
		Static permissible load P _{0a} (N)	735
Permissible input torque (N·m)	Direct coupling		0.12 0.42
	Motor wrap		0.40
Static permissible moment ^{4,5} (N·m)		M _A : 38 (207), M _B : 38 (207), M _C : 98 (197)	
Running life ⁶ (km)		3,000 5,000	
Standard grease/Grease nipple used		THK AFA Grease/PB107	

¹ I_x is the geometric moment of inertia about the X axis.

² I_y is the geometric moment of inertia about the Y axis.

³ The permissible rotational speed may decrease as the stroke becomes longer.

⁴ The value in parentheses is with 2 blocks (B type) attached.

⁵ See p. 116 for the values if "1" or "2" is selected for item ⑦ in the Model Number Coding.

⁶ Calculated under the following conditions.

Stroke: 80 mm (A type), 85 mm (B type) / Speed: 50 mm/s (for 1 mm lead), 300 mm/s (for 6 mm lead) / Load mass: Maximum load capacity (p. 9) / Acceleration/deceleration: As when set to maximum load capacity (p. 9) / Center of gravity: Center of the table's upper surface.

Note 1: LM Guide load rating is the load rating per block.

Accuracy

Accuracy grade	Item	Stroke ⁷		
		30	80	130
Normal grade (no symbol)	Positioning repeatability (mm)	±0.01		
	Positioning accuracy (mm)	Not specified		
	Running parallelism (vertical direction) (mm)	Not specified		
	Backlash (mm)	0.02		
	Starting torque (N·cm)	0.5		

Accuracy grade	Item	Stroke ⁷		
		30	80	130
High accuracy grade (H)	Positioning repeatability (mm)	±0.005		
	Positioning accuracy (mm)	0.06		
	Running parallelism (vertical direction) (mm)	0.025		
	Backlash (mm)	0.01		
	Starting torque (N·cm)	0.5		

Accuracy grade	Item	Stroke ⁷		
		30	80	130
Precision grade (P)	Positioning repeatability (mm)	±0.003		
	Positioning accuracy (mm)	0.02		
	Running parallelism (vertical direction) (mm)	0.01		
	Backlash (mm)	0.003		
	Starting torque (N·cm)	1.2		

⁷ Stroke with 1 block (A type).

Notes: 2. Precision evaluation in accordance with THK standards.

3. Measured using a motor for inspection. With motor wrap specifications, measurements are not made in the completed motor wrap state.

4. The starting torque represents the value when containing THK AFA Grease.

5. The starting torque may exceed standards if using vacuum grease, clean room grease, or other high-viscosity greases, so care should be taken when selecting a motor.

6. Contact THK for accuracy higher than the standard stroke.

Geometric Moment of Inertia

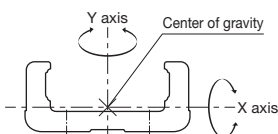

Static Permissible Moment

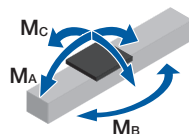

Motor Selection Information

Stroke ¹ (mm)	Outer rail length (mm)	LM Guide				Ball screw		Motor mounting part	
		Moving part mass (kg)			Sliding resistance value ² (N)	Lead (mm)	Shaft length (mm)	Direct coupling	Motor wrap
		Block mass	Sub-table mass	Total mass				Shaft end diameter (mm)	Timing pulley (sum of two) Inertial moment x 10 ⁻⁴ (kg·m ²)
30 to 130	100 to 200	A type: 0.07 B type: 0.14	A type: 0.05 B type: 0.1	A type: 0.12 B type: 0.24	4.8	1, 6	133 to 233	Ø4h7	0.013

¹ Stroke with 1 block (A type).

² Value with 1 block (A type). This value is the sum of the rolling resistance value and seal resistance value.

Note: Refer to p. 19 for applicable couplings.

Permissible Overhang Length³

Horizontal

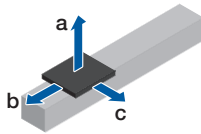

Wall-Mounted

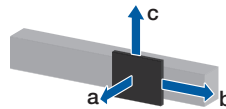

Vertical

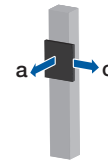

Estimated motor capacity 50 W		Ball screw lead (mm)	Load mass (kg)	a (mm)	b (mm)	c (mm)
Direct coupling	A type	1	3	350	110	160
			6	160	50	80
			12.5	70	20	40
	6	A type	3	350	110	160
			6	160	50	80
			12.5	70	20	40
B type	1	4	400	370	250	
		8.5	400	170	110	
		17.5	260	80	50	
	6	B type	4	400	370	250
			8.5	400	170	110
			17.5	260	80	50

Estimated motor capacity 50 W		Ball screw lead (mm)	Load mass (kg)	a (mm)	b (mm)	c (mm)
Direct coupling	A type	1	2.5	170	110	360
			5	70	50	180
			10	20	20	90
	6	A type	2.5	170	110	360
			5	70	50	180
			10	20	20	90
B type	1	3.5	260	300	400	
		7	120	150	400	
		14	50	70	250	
	6	B type	3.5	260	300	400
			7	120	150	400
			14	50	70	250

Estimated motor capacity 50 W		Ball screw lead (mm)	Load mass (kg)	a (mm)	c (mm)
Direct coupling	A type	1	0.5	400	400
			1.5	150	140
			3	60	70
	6	A type	1.5	150	140
			3	60	70
			6	20	30
B type	1	0.5	400	400	
		1.5	400	400	
		3	360	260	
	6	B type	1.5	400	400
			3.5	310	230
			7	140	110

³ This is the value with the service life of the LM Guide limited to 5,000 km (3,000 km for 1 mm lead only). The calculation conditions are as follows.

Stroke: 80 mm (A type), 60 mm (B type) / Acceleration/deceleration: 0.3 G / Speed: 50 mm/s (for 1 mm lead), 300 mm/s (for 6 mm lead) / Overhang direction: Loaded in only a single direction. Dimensions a, b, and c are from the center of the table's upper surface.

With Cover
Direct Motor Coupling

Dimensions

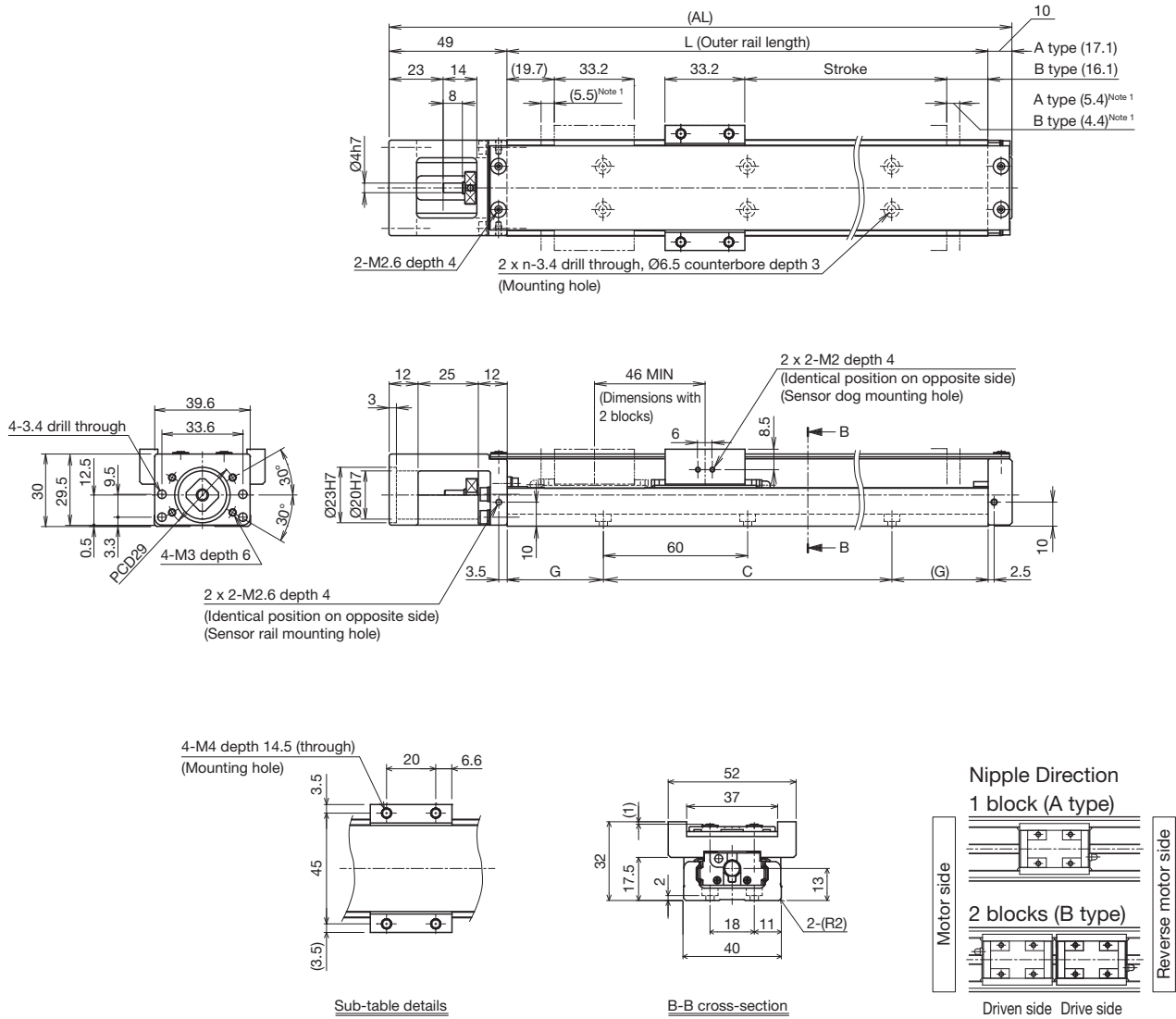

¹ Dimensions from the mechanical stopper to the stroke start position.

Stroke (mm) (Stroke between mechanical stoppers)	A type	30 (40.9)	80 (90.9)	130 (140.9)
	B type ²	-	35 (44.9)	85 (94.9)
Maximum speed ³ (mm/s)	Ball screw lead: 1 mm	100		
	Ball screw lead: 6 mm	600		
Dimensions (mm)	AL	159	209	259
	L	100	150	200
	C	60	120	120
	G	20	15	40
No. of mounting holes	n	2	3	3
Mass ⁴ (kg)		0.55	0.69	0.84

² The value with 2 blocks (B type) attached.

³ The maximum speed is restricted by the actuator's permissible speed.

⁴ The mass with 2 blocks (B type) has 0.12 kg added.

Without Cover
Direct Motor Coupling

Dimensions

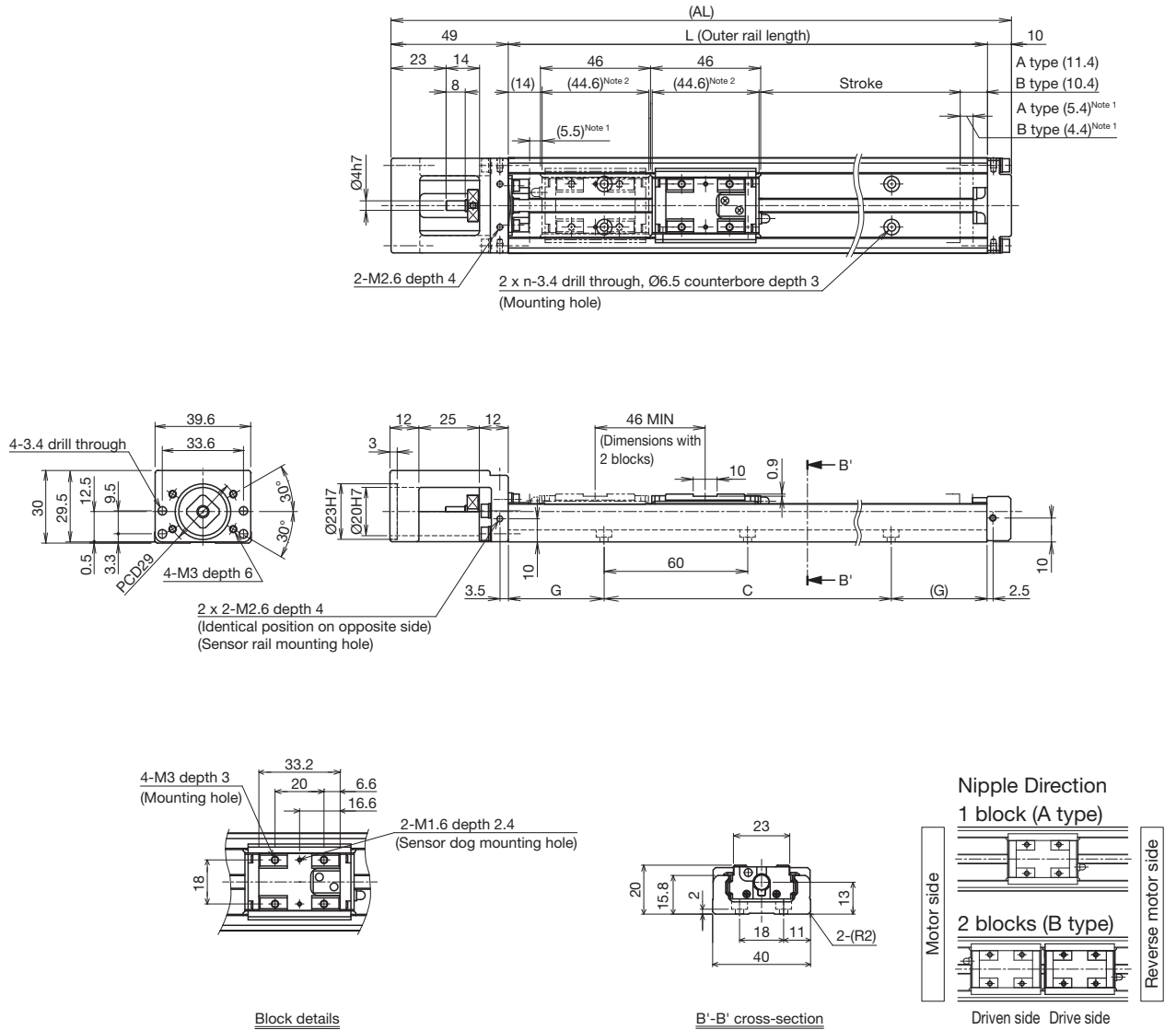

¹ Dimensions from the mechanical stopper to the stroke start position.
² Shows the block length when calculating the enabled stroke range.
 90.6 mm (2 blocks total) for SKR20 with 2 blocks (B type).

Stroke (mm) (Stroke between mechanical stoppers)	A type	30 (40.9)	80 (90.9)	130 (140.9)
	B type ³	-	35 (44.9)	85 (94.9)
Maximum speed ⁴ (mm/s)	Ball screw lead: 1 mm		100	
	Ball screw lead: 6 mm		600	
Dimensions (mm)	AL	159	209	259
	L	100	150	200
	C	60	120	120
	G	20	15	40
No. of mounting holes	n	2	3	3
Mass ⁵ (kg)		0.47	0.6	0.74

³ The value with 2 blocks (B type) attached.
⁴ The maximum speed is restricted by the actuator's permissible speed.
⁵ The mass with 2 blocks (B type) has 0.07 kg added.

With Cover
Motor Wrap

Dimensions

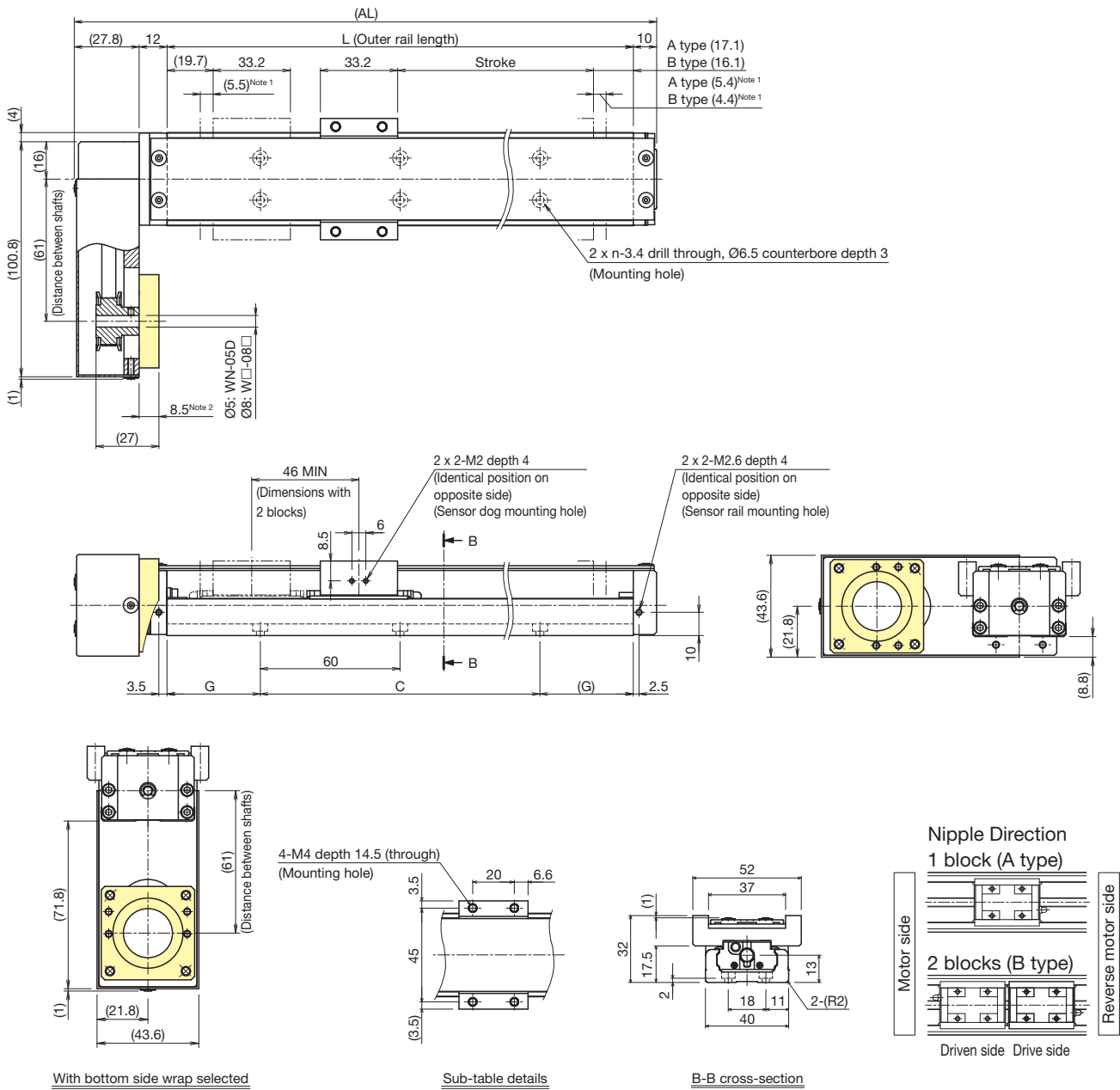

¹ Dimensions from the mechanical stopper to the stroke start position.
² This dimension will be different if "WN" was selected for ⑨ Housing A/ Intermediate flange in the model number coding. See p. 22 for details.

Stroke (mm) (Stroke between mechanical stoppers)	A type	30 (40.9)	80 (90.9)	130 (140.9)
	B type ³	-	35 (44.9)	85 (94.9)
Maximum speed ⁴ (mm/s)	Ball screw lead: 1 mm	100		
	Ball screw lead: 6 mm	600		
Dimensions (mm)	AL	149.8	199.8	249.8
	L	100	150	200
	C	60	120	120
	G	20	15	40
No. of mounting holes	n	2	3	3
	Mass ⁵ (kg)	0.81	0.95	1.09

³ The value with 2 blocks (B type) attached.
⁴ The maximum speed is restricted by the actuator's permissible speed.
⁵ The mass with 2 blocks (B type) has 0.12 kg added.

Without Cover
Motor Wrap

Dimensions

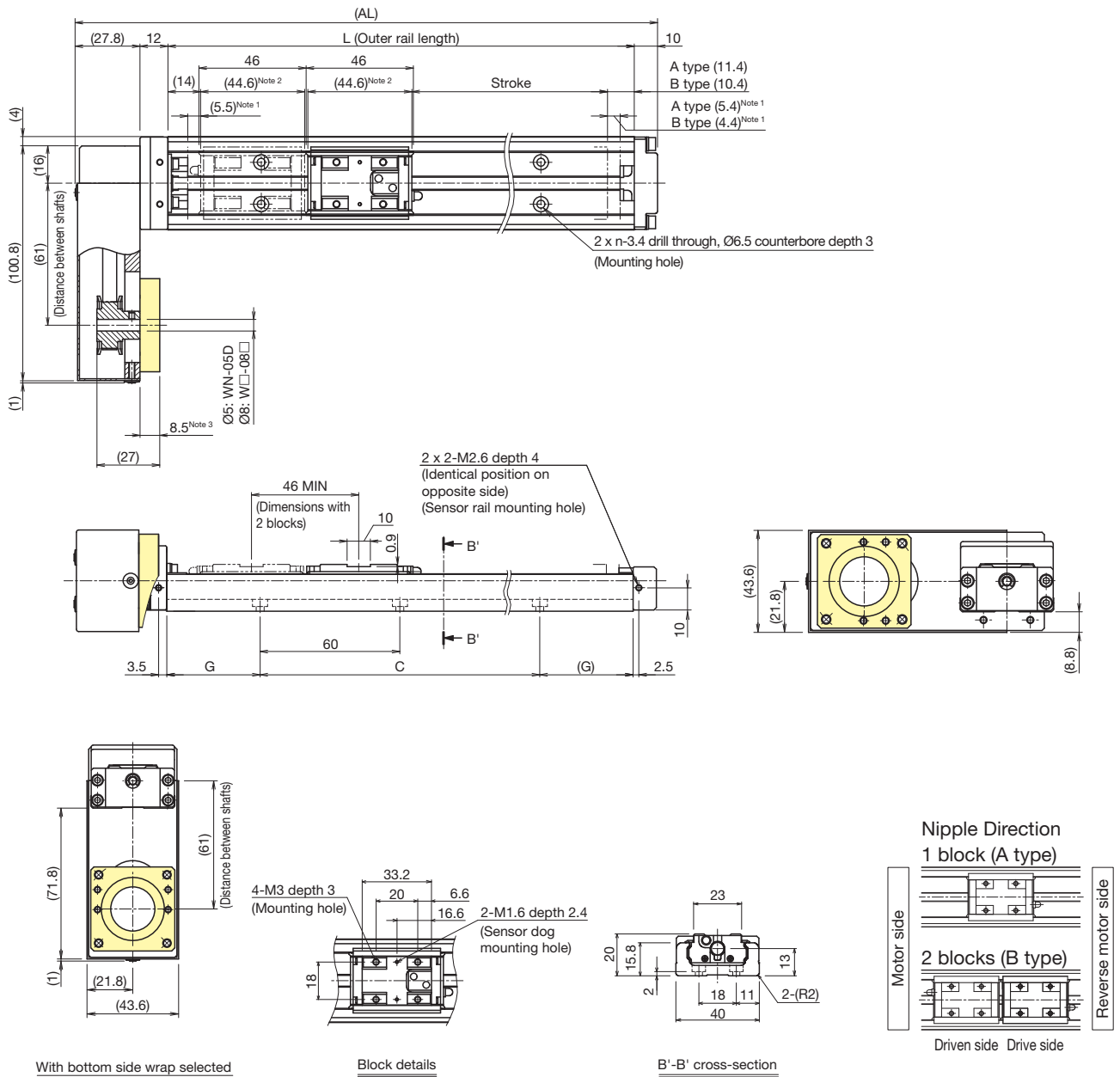

With bottom side wrap selected

Block details

B'-B' cross-section

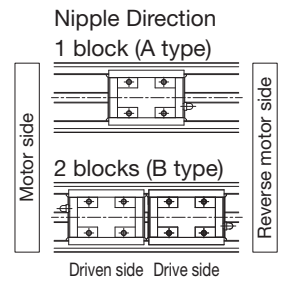

¹ Dimensions from the mechanical stopper to the stroke start position.
² Shows the block length when calculating the enabled stroke range. 90.6 mm (2 blocks total) for SKR20 with 2 blocks (B type).
³ This dimension will be different if "WN" was selected for ⑨ Housing A/ Intermediate flange in the model number coding. See p. 22 for details.

Stroke (mm) (Stroke between mechanical stoppers)	A type	30 (40.9)	80 (90.9)	130 (140.9)
		B type ⁴	-	35 (44.9)
Maximum speed ⁵ (mm/s)	Ball screw lead: 1 mm		100	
	Ball screw lead: 6 mm		600	
Dimensions (mm)	AL	149.8	199.8	249.8
	L	100	150	200
	C	60	120	120
	G	20	15	40
No. of mounting holes	n	2	3	3
Mass ⁶ (kg)		0.72	0.86	0.99

⁴ The value with 2 blocks (B type) attached.
⁵ The maximum speed is restricted by the actuator's permissible speed.
⁶ The mass with 2 blocks (B type) has 0.07 kg added.

Options

Sensors

Optional photo sensors and proximity sensors are available. Sensor-equipped models also feature a dedicated sensor rail and sensor dog.

Sensors, sensor rails, and sensor dogs can be mounted on both sides when the stroke is less than 70 mm.

Mounting example

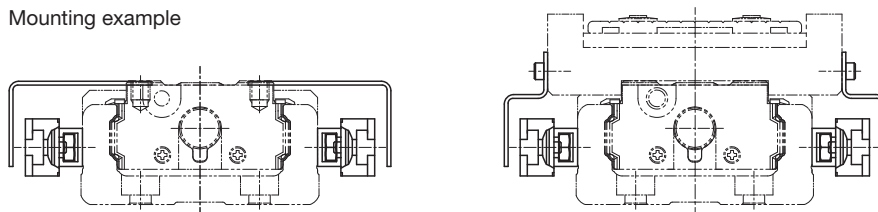

Symbol	Description	Model	Accessories
0	None	-	-
1	With sensor rail	-	Mounting screws, sensor rail (x1 or 2)
2	Photo sensor ¹ (x3)	EE-SX671 (OMRON Corporation)	Mounting screws, nuts, sensor dog (x1 or 2), sensor rail (x1 or 2), mounting plates (x3), connectors (EE-1001 x3)
6	Photo sensor ¹ (x3)	EE-SX674 (OMRON Corporation)	Mounting screws, nuts, sensor dog (x1 or 2), sensor rail (x1 or 2), mounting plates (x3), connectors (EE-1001 x3)
7	Proximity sensor N.O. contact ² (x3)	APM-D3A1-001 (Azbil Corporation)	Mounting screws, nuts, sensor dog (x1 or 2), sensor rail (x1 or 2)
B	Proximity sensor N.C. contact ³ (x3)	APM-D3B1-003 (Azbil Corporation)	Mounting screws, nuts, sensor dog (x1 or 2), sensor rail (x1 or 2)
E	Proximity sensor N.O. contact ² (x1) N.C. contact ³ (x2)	APM-D3A1-001 (Azbil Corporation) APM-D3B1-003 (Azbil Corporation)	Mounting screws, nuts, sensor dog (x1 or 2), sensor rail (x1 or 2)
H	Proximity sensor N.O. contact ² (x3)	GX-F12A (Panasonic Industry Co., Ltd.)	Mounting screws, nuts, sensor dog (x1 or 2), sensor rail (x1 or 2)
L	Proximity sensor N.C. contact ³ (x3)	GX-F12B (Panasonic Industry Co., Ltd.)	Mounting screws, nuts, sensor dog (x1 or 2), sensor rail (x1 or 2)
J	Proximity sensor N.O. contact ² (x1) N.C. contact ³ (x2)	GX-F12A (Panasonic Industry Co., Ltd.) GX-F12B (Panasonic Industry Co., Ltd.)	Mounting screws, nuts, sensor dog (x1 or 2), sensor rail (x1 or 2)
M	Proximity sensor N.O. contact ² (x1) (PNP output) N.C. contact ³ (x2) (PNP output)	GX-F12A-P (Panasonic Industry Co., Ltd.) GX-F12B-P (Panasonic Industry Co., Ltd.)	Mounting screws, nuts, sensor dog (x1 or 2), sensor rail (x1 or 2)

¹ The photo sensors can be switched between ON when lit and ON when unlit.

² N.O. contact: Normally open contact point

³ N.C. contact: Normally closed contact point

Notes: 1. If proximity sensors are close to one another, they may not function properly. If that happens, please prepare a type with a different frequency.

2. Mounting of sensors other than those in the table above is possible. Contact THK for details.

Sensor Rail Mounting Dimensions

Mounting only a sensor rail is also possible.

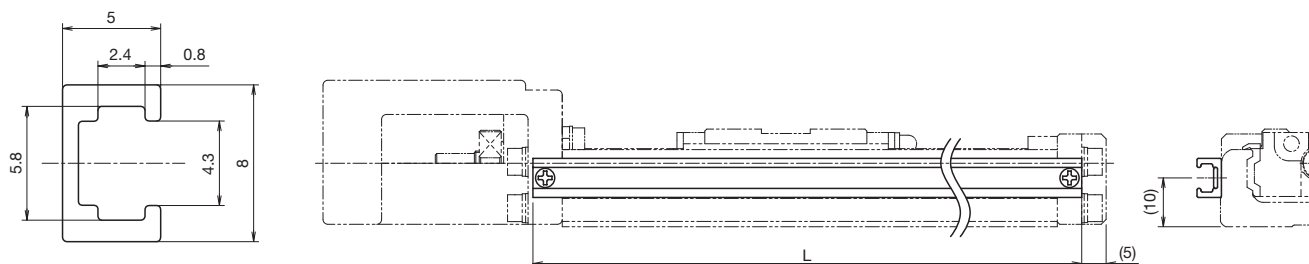

Stroke ⁴ (mm)	Outer rail length (mm)	L (mm)
30	100	111
80	150	161
130	200	211

⁴ Stroke with 1 block (A type).

Photo Sensor Mounting Dimensions

Connector: EE-1001 (OMRON Corporation) x3 included.
To be mounted by the customer.

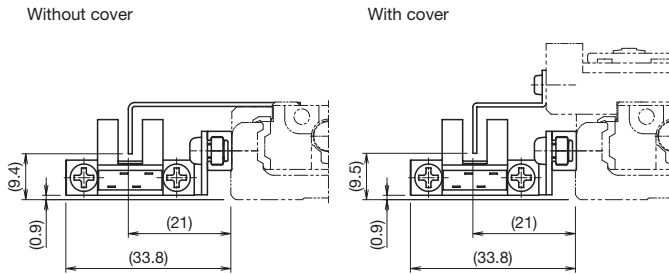

Symbol	Model	Manufacturer
2	EE-SX671	OMRON Corporation

Sensor dog width: 10 mm

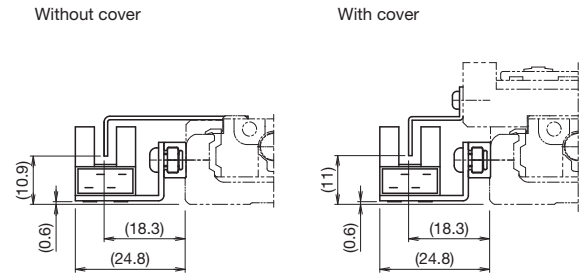

Symbol	Model	Manufacturer
6	EE-SX674	OMRON Corporation

Sensor dog width: 10 mm

Proximity Sensor Mounting Dimensions

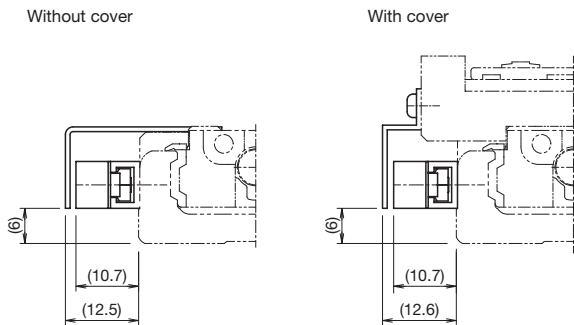

Symbol	Model	Manufacturer
7, B, E	APM-D3A1-001	Azbil Corporation
	APM-D3B1-003	

Sensor dog width: 10 mm

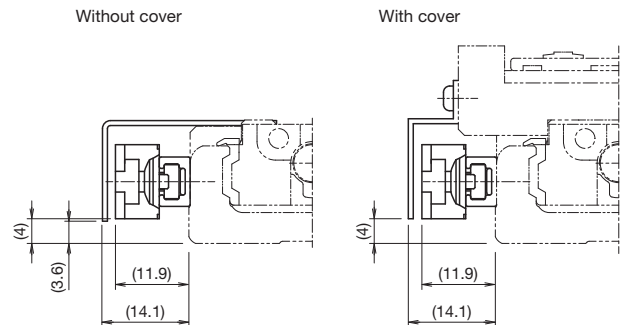

Symbol	Model	Manufacturer
H, L, J	GX-F12A	Panasonic Industry Co., Ltd.
	GX-F12B	
M	GX-F12A-P	
	GX-F12B-P	

Sensor dog width: 10 mm

Options

Intermediate Flange (Direct Coupling)

Several types of intermediate flanges for mounting motors are available.

When selecting "0" or "1" for Model Number Coding ⑥ With/without motor, specify an intermediate flange that matches the motor used.

Compatibility Table: Motors Used, Intermediate Flanges, and Couplings

Motor type	Manufacturer	Motor model		Motor rated output (W)	Flange size	Housing A/ Intermediate flange	Compatible coupling models		
							MIKI PULLEY CO., LTD.	Nabeya Bi-tech Kaisha (NBK)	
AC servo motor	YASKAWA Electric Corporation	Σ-Vmini	SGMMV-A1	10	25×25	AN	SFC-010DA2-4B-5B-L32	XGT2-15C-4-5	
			SGMMV-A2	20					
			SGMMV-A3	30					
		Σ-V	SGMJV-A5	50	40×40	AQ	SFC-010DA2-4B-8B	XGT2-19C-4-8	
			SGMAV-A5						
			SGM7J-A5	50	40×40	AQ			
		SGM7A-A5							
		Σ-7	SGMXA-A5	50	40×40	AQ	SFC-010DA2-4B-8B	XGT2-19C-4-8	
			SGMXJ-A5						
		Σ-X	SGMXA-A5	50	40×40	AQ	SFC-010DA2-4B-8B	XGT2-19C-4-8	
	SGMXJ-A5								
	Mitsubishi Electric Corporation	MELSERVO	J4	HG-AK0136	10	25×25	AN	SFC-010DA2-4B-5B-L32	XGT2-15C-4-5
				HG-AK0236	20				
				HG-AK0336	30				
			J5	HG-KR053	50	40×40	AQ	SFC-010DA2-4B-8B	XGT2-19C-4-8
				HG-MR053					
				HK-KT053W	50	40×40	AQ		
	JN	HF-KN053	50	40×40	AQ	SFC-010DA2-4B-8B	XGT2-19C-4-8		
	TAMAGAWA SEIKI CO., LTD.	TBL-iii	TS4602	50	40×40	AQ	SFC-010DA2-4B-8B	XGT2-19C-4-8	
		TBL-iv	TSM3102						
Panasonic Corporation	MINAS	A5	MSMD5A	50	38×38	AP	SFC-010DA2-4B-8B	XGT2-19C-4-8	
			MSME5A						
		A6	MSMF5A	50	38×38	AP	SFC-010DA2-4B-8B	XGT2-19C-4-8	
			MHMF5A		40×40	AQ			
KEYENCE CORPORATION	SV	SV-M005	50	40×40	AQ	SFC-010DA2-4B-8B	XGT2-19C-4-8		
	SV2	SV2-M005							
SANYO DENKI CO., LTD.	SANMOTION R	R2□A04005	50	40×40	AQ	SFC-010DA2-4B-8B	XGT2-19C-4-8		
OMRON Corporation	OMNUC G5	R88M-K05030	50	40×40	AQ	SFC-010DA2-4B-8B	XGT2-19C-4-8		
FANUC CORPORATION	β is Series	βis0.2/5000	50	40×40	AQ	SFC-010DA2-4B-8B	XGT2-19C-4-8		

Motor type	Manufacturer	Motor model		Flange size	Housing A/ Intermediate flange	Compatible coupling models		
						MIKI PULLEY CO., LTD.	Nabeya Bi-tech Kaisha (NBK)	
Stepper motor	ORIENTAL MOTOR CO., LTD.	α step	AZ2*, AR2*	28×28	AS	SFC-010DA2-4B-5B-L32	XGT2-15C-4-5	
			AZ4*, AR4* (excluding AZM48)	42×42	AR	SFC-010DA2-4B-6B	XGT2-15C-4-6	
			AZM48			SFC-010DA2-4B-8B	XGT2-19C-4-8	
		5-phase	CRK	CRK52*	28×28	AS	SFC-010DA2-4B-5B-L32	XGT2-15C-4-5
				CRK54*	42×42	AR	SFC-010DA2-4B-5B	
			RKII	RKS54*	42×42	AR	SFC-010DA2-4B-6B	XGT2-15C-4-6
				PKP52*	28×28	AS	SFC-010DA2-4B-5B-L32	XGT2-15C-4-5
				PKP54*	42×42	AR	SFC-010DA2-4B-5B	
		2-phase	PKP/CVD	PKP22*	28×28	AS	SFC-010DA2-4B-5B-L32	XGT2-15C-4-5
				PKP24*	42×42	AR	SFC-010DA2-4B-5B	
		KEYENCE CORPORATION	2-phase	QS-M28	28×28	AS	SFC-010DA2-4B-5B-L32	XGT2-15C-4-5
				QS-M42	42×42	AR	SFC-010DA2-4B-5B	
	SANYO DENKI CO., LTD.	PB	PBDM28*	28×28	AS	SFC-010DA2-4B-5B	XGT2-15C-4-5	
			PBDM423, PBA**423	42×42	AR	SFC-010DA2-4B-6B	XGT2-15C-4-6	
			FAF/FDF52*	28×28	AS	SFC-010DA2-4B-5B-L32	XGT2-15C-4-5	
		5-phase	FAF54*/FDF54*/FA511M42/FB511M42	42×42	AR	SFC-010DA2-4B-6B	XGT2-15C-4-6	
			D*14S28*	28×28	AS	SFC-010DA2-4B-5B-L32	XGT2-15C-4-5	
		2-phase	DB14H52*	42×42	AR	SFC-010DA2-4B-5B	XGT2-15C-4-5	
DU15H52*								

Notes: 1. The table shows only a portion of the model numbers for motors. For details regarding model numbers, please see the catalog for each respective motor manufacturer.

2. If the maximum torque for motors exceeds the permissible input torque (p. 11), please consider a safety measure to limit the torque.

3. When installing a motor other than the motor model numbers listed above, contact THK.

Housing A

SKR20
A0

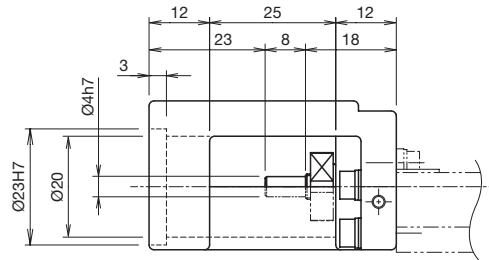
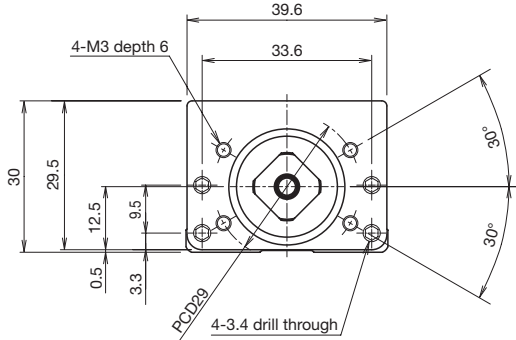

SKR**	Actuator model
●◇	●: Housing A ◇: Intermediate flange

Intermediate Flange

SKR20
AP

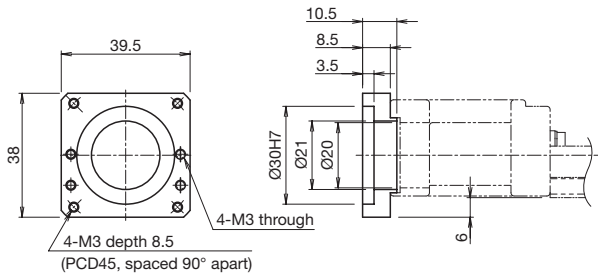

SKR20
AQ

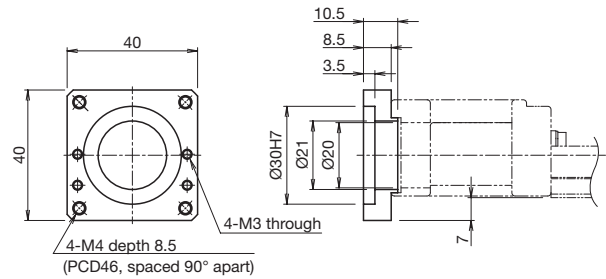

SKR20
AR

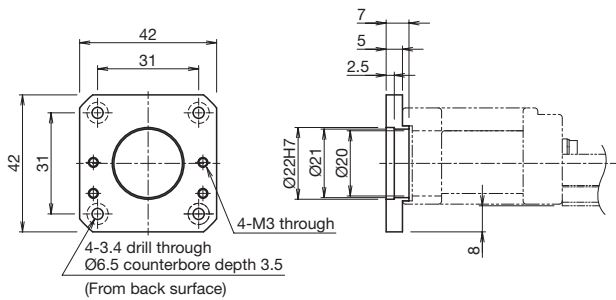

SKR20
AS

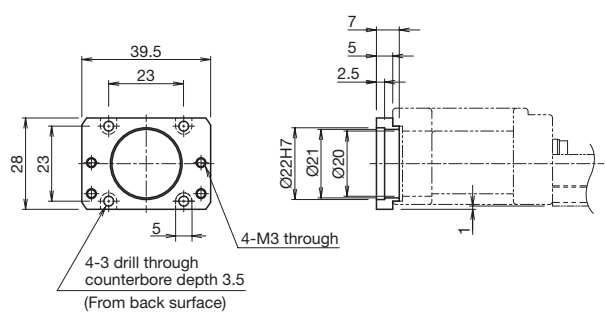

SKR20
AN

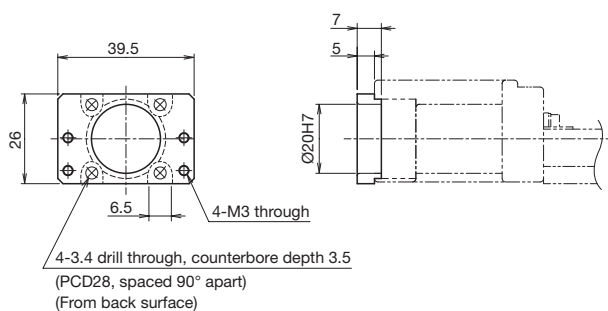

Options

Intermediate Flange (Motor Wrap)

Several types of intermediate flanges for mounting motors are available.

When selecting "R1," "R2," "R3," "R4," "R5," or "R6" for Model Number Coding ⑥ With/without motor, specify an intermediate flange that matches the motor used.

Symbol Coding

Motor wrap symbol ①	Intermediate flange ②	Motor shaft diameter (mm) ③	Motor shaft securing method ④
W	Q	08	D
W	Refer to the Compatibility Table: Motors Used and Motor Wrap Symbols below.	Specify a motor shaft diameter. (Refer to the Compatibility Table: Motors Used and Motor Wrap Symbols below.)	K: Key D: D-cut

Motor Shaft Securing Method

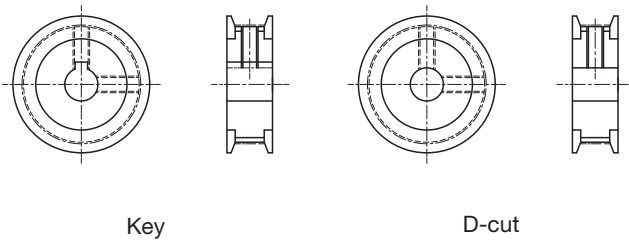

Compatibility Table: Motors Used and Motor Wrap Symbols

Motor type	Manufacturer	Motor model	Motor rated output (W)	Flange size	Housing A/Intermediate flange		
AC servo motor	YASKAWA Electric Corporation	Σ-Vmini	SGMMV-A1	10	25×25	WN-05D	
			SGMMV-A2	20			
			SGMMV-A3	30			
		Σ-V	SGMJV-A5	50	40×40	WQ-08K	
			SGMAV-A5				
		Σ-7	SGM7J-A5	50	40×40	WQ-08K	
			SGM7A-A5				
		Σ-X	SGMXJ-A5	50	40×40	WQ-08K	
			SGMXA-A5				
		Mitsubishi Electric Corporation	MELSERVO	J4	HG-AK0136	10	25×25
	HG-AK0236				20		
	HG-AK0336				30		
	J5			HG-MR053	50	40×40	WQ-08D
				HG-KR053			
				HK-KT053W			
	JN	HF-KN053	50	40×40	WQ-08D		
	TAMAGAWA SEIKI CO., LTD.	TBL-iii	TS4602	50	40×40	WQ-08D	
		TBL-iiV	TSM3102				
	Panasonic Corporation	MINAS	A5	M5MD5A	50	38×38	WP-08D, WP-08K
M5ME5A							
A6			M6MF5A	50	40×40	WQ-08K	
			M6HM5A				
KEYENCE CORPORATION	SV	SV-M005	50	40×40	WQ-08K		
	SV2	SV2-M005					
SANYO DENKI CO., LTD.	SANMOTION R	R2□A04005	50	40×40	WQ-08K		
OMRON Corporation	OMNUC G5	R88M-K05030	50	40×40	WQ-08K		
FANUC CORPORATION	β is Series	βis0.2/5000	50	40×40	WQ-08K		

Notes: 1. The table shows only a portion of the model numbers for motors. For details regarding model numbers, please see the catalog for each respective motor manufacturer.
 2. If the maximum torque for motors exceeds the permissible input torque (p. 11), please consider a safety measure to limit the torque.
 3. When installing a motor other than the motor model numbers listed above, contact THK.

Motor Wrap Housing A

SKR20
20

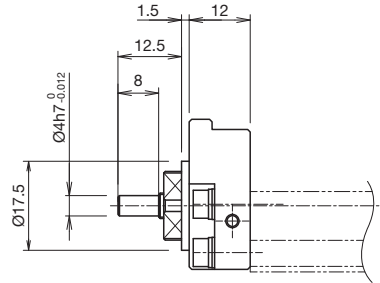
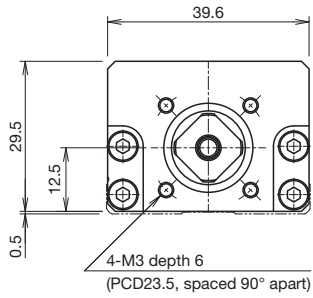

Note: The shaft end must be considered separately with motor wrap types.
Contact THK for details.

SKR**	Actuator model
●◇	●: Housing A ◇: Intermediate flange

Motor Wrap Specification (Intermediate Flange)

SKR20
WP

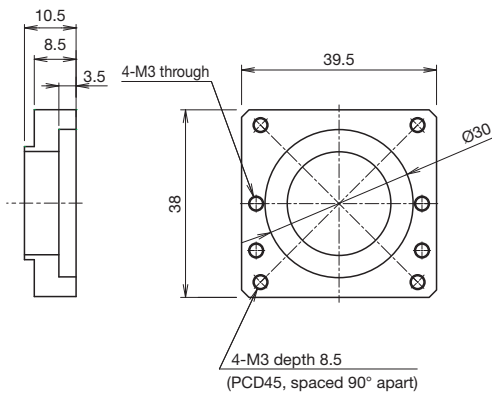

SKR20
WQ

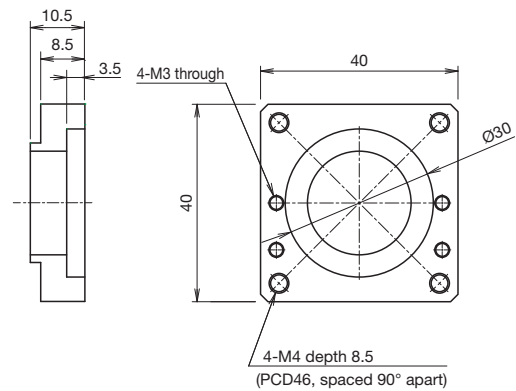

SKR**	Actuator model
W□	□: Intermediate flange

SKR20
WN

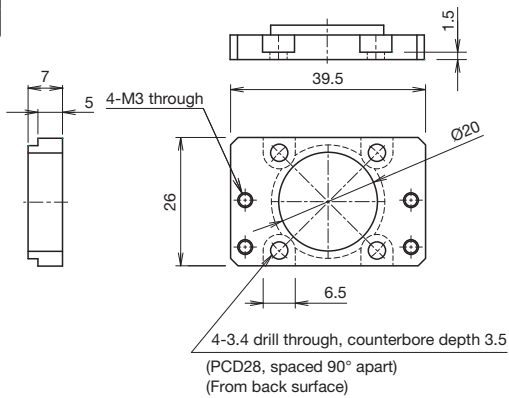

SKR26 A/B

Direct motor coupling	Motor wrap	Width 50 mm	Height 26 mm	Max. stroke 210 mm
-----------------------	------------	-------------	--------------	--------------------

Model Number Coding

Model	Ball screw lead	Block type	Stroke	Accuracy grade	With/without motor	Cover	Sensors	Housing A/ Intermediate flange
①	②	③	④	⑤	⑥	⑦	⑧	⑨
SKR26	02	A	0060	P	0	1	2	AQ
SKR26	02: 2 mm 06: 6 mm	A: x1 B: x2	0045: 45 mm to 0210: 210 mm	No symbol: Normal grade H: High accuracy grade P: Precision grade	With direct coupling 0: Direct coupling (without motor) 1: Direct coupling (THK will purchase and mount the motor you specify.) With motor wrap R1: Non-standard side wrap (without motor) R2: Standard side wrap (without motor) R3: Bottom side wrap (without motor) R4: Non-standard side wrap (THK will purchase and mount the motor you specify.) R5: Standard side wrap (THK will purchase and mount the motor you specify.) R6: Bottom side wrap (THK will purchase and mount the motor you specify.)	0: Without cover 1: With cover 2: With bellows	0 1 2 6 7 B E H L J M Sensor details → p. 29	With direct coupling A0 AN AP AQ AR AS 20 With motor wrap WN-05D WP-08D WP-08K WQ-08D WQ-08K
			When selecting 2: With bellows for ⑦ Cover, specify the stroke with bellows. → p. 109 to p. 110		When selecting "0": A coupling is not provided. Indicate when placing an order if a coupling is required. When selecting "1," "R4," "R5," or "R6": The specified motor will be installed. Indicate the motor cable direction separately. Select ⑨ Intermediate flange to match the specified motor.		With direct coupling → p. 31 With motor wrap → p. 33	

③ Block Type

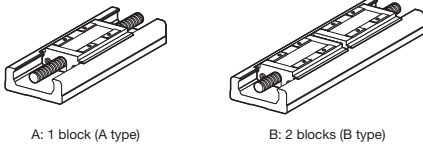

⑥ Motor Mounting Method

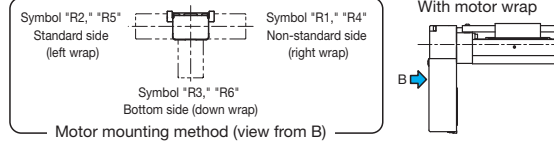

Selection Materials

Basic Specifications

LM Guide	Basic dynamic load rating C (N)		13,000
	Basic static load rating C ₀ (N)		16,500
	Radial clearance (mm)	Normal grade/High accuracy grade (H)	-0.006 to 0
		Precision grade (P)	-0.007 to -0.006
	Geometric moment of inertia	I _x ¹ (mm ⁴)	1.66×10 ⁴
I _y ² (mm ⁴)		1.48×10 ⁵	
Mass (kg/m)		3.9	
Ball screw	Ball screw lead (mm)		2 6
	Basic dynamic load rating C _a (N)	Normal grade/High accuracy grade (H)	2,350 1,950
		Precision grade (P)	2,390
	Basic static load rating C _{0a} (N)	Normal grade/High accuracy grade (H)	4,020 3,510
		Precision grade (P)	3,900
	Screw shaft diameter (mm)		Ø8
	Thread minor diameter (mm)		Ø6.6 Ø6.7
	Ball center-to-center diameter (mm)		Ø8.3 Ø8.4
Permissible rotational speed ³ (min ⁻¹)	Normal grade/High accuracy grade (H)	6,000	
	Precision grade (P)		
Bearing (Fixed side)	Axial direction	Basic dynamic load rating C _a (N)	2,000
		Static permissible load P _{0a} (N)	1,230
Permissible input torque (N·m)	Direct coupling	0.43	0.80
	Motor wrap	0.40	
Static permissible moment ^{4,5} (N·m)		M _A : 117 (589), M _B : 117 (589) M _C : 265 (530)	
Running life ⁶ (km)		3,000	5,000
Standard grease/Grease nipple used		THK AFA Grease/PB107	

¹ I_x is the geometric moment of inertia about the X axis.

² I_y is the geometric moment of inertia about the Y axis.

³ The permissible rotational speed may decrease as the stroke becomes longer.

⁴ The value in parentheses is with 2 blocks (B type) attached.

⁵ See p. 116 for the values if "1" or "2" is selected for item ⑦ in the Model Number Coding.

⁶ Calculated under the following conditions.

Stroke: 160 mm (A type), 95 mm (B type) / Speed: 100 mm/s (for 2 mm lead), 300 mm/s (for 6 mm lead) / Load mass: Maximum load capacity (p. 9) / Acceleration/deceleration: As when set to maximum load capacity (p. 9) / Center of gravity: Center of the table's upper surface.

Note 1: LM Guide load rating is the load rating per block.

Geometric Moment of Inertia

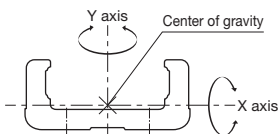

Static Permissible Moment

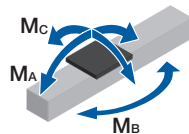

Accuracy

Accuracy grade	Item	Stroke ⁷			
		60	110	160	210
Normal grade (no symbol)	Positioning repeatability (mm)	±0.01			
	Positioning accuracy (mm)	Not specified			
	Running parallelism (vertical direction) (mm)	Not specified			
	Backlash (mm)	0.02			
	Starting torque (N·cm)	1.5			

Accuracy grade	Item	Stroke ⁷			
		60	110	160	210
High accuracy grade (H)	Positioning repeatability (mm)	±0.005			
	Positioning accuracy (mm)	0.06			
	Running parallelism (vertical direction) (mm)	0.025			
	Backlash (mm)	0.01			
	Starting torque (N·cm)	1.5			

Accuracy grade	Item	Stroke ⁷			
		60	110	160	210
Precision grade (P)	Positioning repeatability (mm)	±0.003			
	Positioning accuracy (mm)	0.02			
	Running parallelism (vertical direction) (mm)	0.01			
	Backlash (mm)	0.003			
	Starting torque (N·cm)	4			

⁷ Stroke with 1 block (A type).

Notes: 2. Precision evaluation in accordance with THK standards.

3. Measured using a motor for inspection. With motor wrap specifications, measurements are not made in the completed motor wrap state.

4. The starting torque represents the value when containing THK AFA Grease.

5. The starting torque may exceed standards if using vacuum grease, clean room grease, or other high-viscosity greases, so care should be taken when selecting a motor.

6. Contact THK for accuracy higher than the standard stroke.

Motor Selection Information

Stroke ¹ (mm)	Outer rail length (mm)	LM Guide				Ball screw		Motor mounting part	
		Moving part mass (kg)			Sliding resistance value ² (N)	Lead (mm)	Shaft length (mm)	Direct coupling	Motor wrap
		Block mass	Sub-table mass	Total mass				Shaft end diameter (mm)	Timing pulley (sum of two) Inertial moment x 10 ⁻⁴ (kg·m ²)
60 to 210	150 to 300	A type: 0.17 B type: 0.34	A type: 0.08 B type: 0.16	A type: 0.25 B type: 0.5	5.7	2, 6	190 to 340	Ø5h7	0.013

¹ Stroke with 1 block (A type).

² Value with 1 block (A type). This value is the sum of the rolling resistance value and seal resistance value.

Note: Refer to p. 31 for applicable couplings.

Permissible Overhang Length³

Horizontal

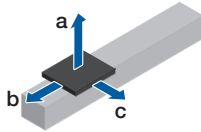

Wall-Mounted

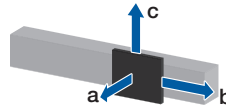

Vertical

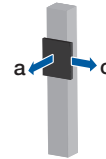

Estimated motor capacity 50 W		Ball screw lead (mm)	Load mass (kg)	a (mm)	b (mm)	c (mm)
Direct coupling	A type	2	6.5	500	180	170
			13.5	270	80	80
			27.5	120	40	40
	B type	6	6.5	500	180	170
			13.5	270	80	80
			27.5	120	40	40
Motor wrap	A type	2	9.5	500	500	230
			19	500	300	110
			38.5	470	150	50
	B type	6	9.5	500	500	230
			19	500	300	110
			38.5	470	150	50

Estimated motor capacity 50 W		Ball screw lead (mm)	Load mass (kg)	a (mm)	b (mm)	c (mm)
Direct coupling	A type	2	5.5	170	110	390
			11	70	50	190
			22	20	20	90
	B type	6	5.5	170	110	390
			11	70	50	190
			22	20	20	90
Motor wrap	A type	2	7.5	270	240	500
			15.5	110	110	390
			31	40	50	190
	B type	6	7.5	270	240	500
			15.5	110	110	390
			31	40	50	190

Estimated motor capacity 50 W		Ball screw lead (mm)	Load mass (kg)	a (mm)	c (mm)
Direct coupling	A type	2	3.5	230	140
			7	100	70
			14	40	30
	B type	6	1.5	500	330
			3.5	230	140
			7	100	70
Motor wrap	A type	2	3.5	500	390
			7	500	190
			14	290	90
	B type	6	2	500	500
			4.5	500	310
			9.5	440	140

³ This is the value with the service life of the LM Guide limited to 5,000 km (3,000 km for 1 mm lead only). The calculation conditions are as follows.

Stroke: 135 mm (A type), 95 mm (B type) / Acceleration/deceleration: 0.3 G / Speed: 100 mm/s (for 2 mm lead), 300 mm/s (for 6 mm lead) / Overhang direction: Loaded in only a single direction. Dimensions a, b, and c are from the center of the table's upper surface.

With Cover
Direct Motor Coupling

Dimensions

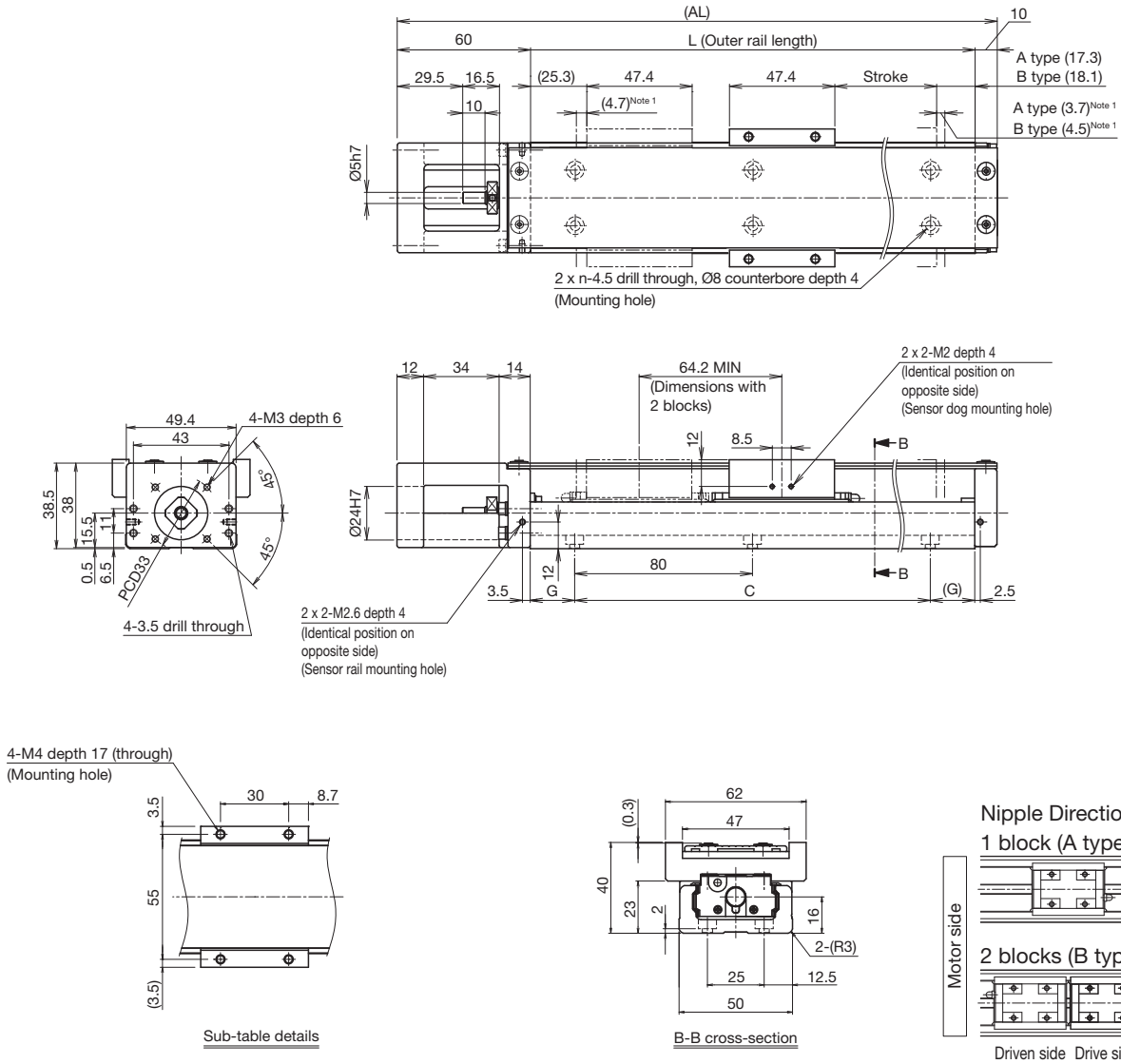

¹ Dimensions from the mechanical stopper to the stroke start position.

Stroke (mm) (Stroke between mechanical stoppers)	A type	60 (68.4)	110 (118.4)	160 (168.4)	210 (218.4)
	B type ²	-	45 (54.2)	95 (104.2)	145 (154.2)
Maximum speed ³ (mm/s)	Ball screw lead: 2 mm	200			
	Ball screw lead: 6 mm	600			
Dimensions (mm)	AL	220	270	320	370
	L	150	200	250	300
	C	80	160	160	240
	G	35	20	45	30
No. of mounting holes	n	2	3	3	4
Mass ⁴ (kg)		1.17	1.39	1.61	1.83

² The value with 2 blocks (B type) attached.

³ The maximum speed is restricted by the actuator's permissible speed.

⁴ The mass with 2 blocks (B type) has 0.25 kg added.

Without Cover
Direct Motor Coupling

Dimensions

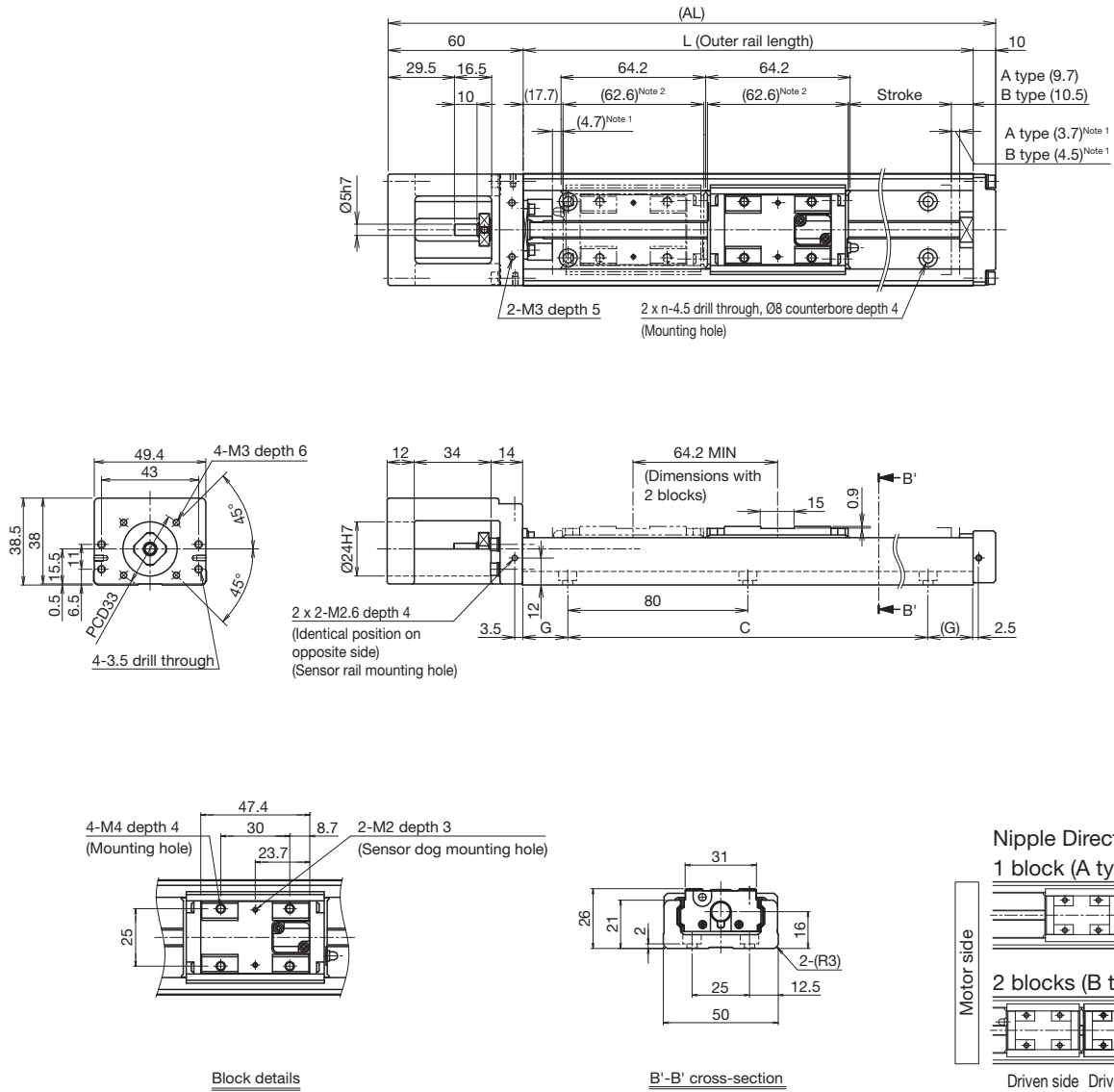

¹ Dimensions from the mechanical stopper to the stroke start position.
² Shows the block length when calculating the enabled stroke range. 126.8 mm (2 blocks total) for SKR26 with 2 blocks (B type).

Stroke (mm) (Stroke between mechanical stoppers)	A type	60 (68.4)	110 (118.4)	160 (168.4)	210 (218.4)
	B type ³	-	45 (54.2)	95 (104.2)	145 (154.2)
Maximum speed ⁴ (mm/s)	Ball screw lead: 2 mm	200			
	Ball screw lead: 6 mm	600			
Dimensions (mm)	AL	220	270	320	370
	L	150	200	250	300
	C	80	160	160	240
	G	35	20	45	30
No. of mounting holes	n	2	3	3	4
Mass ⁵ (kg)		1.01	1.22	1.43	1.64

³ The value with 2 blocks (B type) attached.
⁴ The maximum speed is restricted by the actuator's permissible speed.
⁵ The mass with 2 blocks (B type) has 0.17 kg added.

With Cover
Motor Wrap

Dimensions

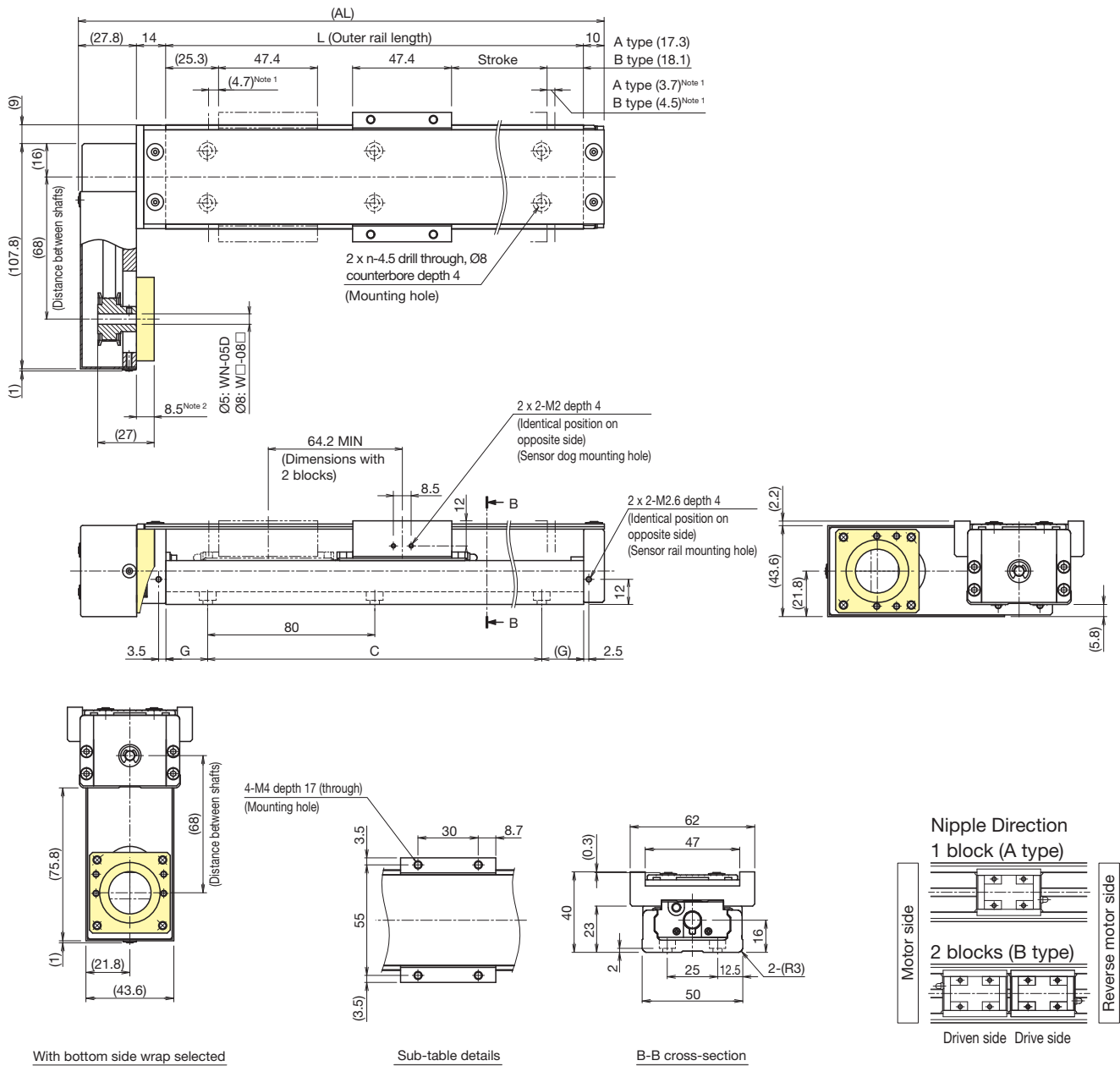

¹ Dimensions from the mechanical stopper to the stroke start position.
² This dimension will be different if "WN" was selected for ⑨ Housing A/ Intermediate flange in the model number coding. See p. 34 for details.

Stroke (mm) (Stroke between mechanical stoppers)	A type	60 (68.4)	110 (118.4)	160 (168.4)	210 (218.4)
	B type ³	-	45 (54.2)	95 (104.2)	145 (154.2)
Maximum speed ⁴ (mm/s)	Ball screw lead: 2 mm	200			
	Ball screw lead: 6 mm	600			
Dimensions (mm)	AL	201.8	251.8	301.8	351.8
	L	150	200	250	300
	C	80	160	160	240
	G	35	20	45	30
No. of mounting holes	n	2	3	3	4
Mass ⁵ (kg)		1.39	1.61	1.84	2.06

³ The value with 2 blocks (B type) attached.
⁴ The maximum speed is restricted by the actuator's permissible speed.
⁵ The mass with 2 blocks (B type) has 0.25 kg added.

Without Cover
Motor Wrap

Dimensions

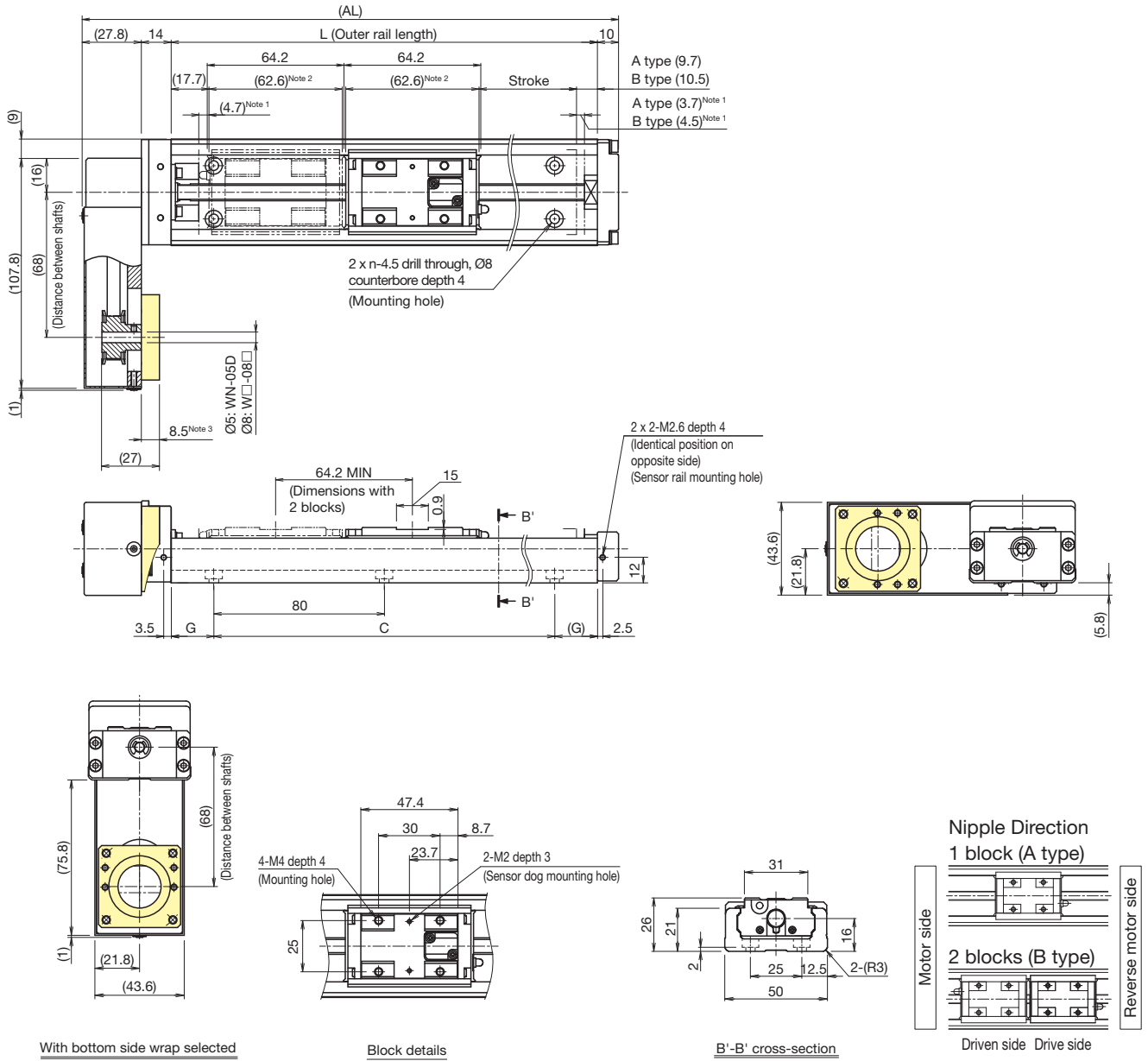

With bottom side wrap selected

Block details

B'-B' cross-section

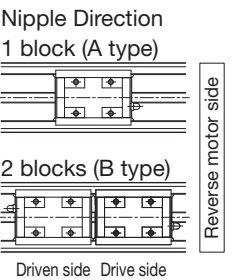

¹ Dimensions from the mechanical stopper to the stroke start position.
² Shows the block length when calculating the enabled stroke range. 126.8 mm (2 blocks total) for SKR26 with 2 blocks (B type).
³ This dimension will be different if "WN" was selected for ⑨ Housing A/ Intermediate flange in the model number coding. See p. 34 for details.

Stroke (mm) (Stroke between mechanical stoppers)	A type	60 (68.4)	110 (118.4)	160 (168.4)	210 (218.4)
	B type ⁴	-	45 (54.2)	95 (104.2)	145 (154.2)
Maximum speed ⁵ (mm/s)	Ball screw lead: 2 mm	200			
	Ball screw lead: 6 mm	600			
Dimensions (mm)	AL	201.8	251.8	301.8	351.8
	L	150	200	250	300
	C	80	160	160	240
	G	35	20	45	30
No. of mounting holes	n	2	3	3	4
Mass ⁶ (kg)		1.24	1.45	1.66	1.87

⁴ The value with 2 blocks (B type) attached.
⁵ The maximum speed is restricted by the actuator's permissible speed.
⁶ The mass with 2 blocks (B type) has 0.17 kg added.

Options

Sensors

Optional photo sensors and proximity sensors are available. Sensor-equipped models also feature a dedicated sensor rail and sensor dog.

Sensors, sensor rails, and sensor dogs can be mounted on both sides when the stroke is less than 70 mm.

Mounting example

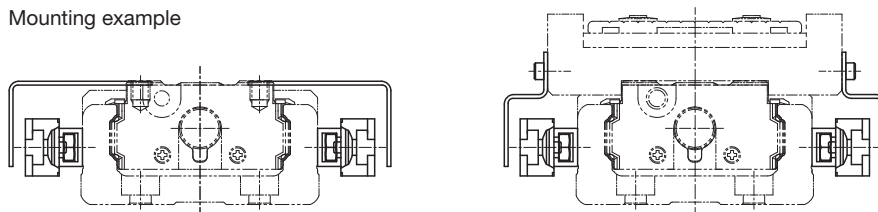

Symbol	Description	Model	Accessories
0	None	-	-
1	With sensor rail	-	Mounting screws, sensor rail (x1 or 2)
2	Photo sensor ¹ (x3)	EE-SX671 (OMRON Corporation)	Mounting screws, nuts, sensor dog (x1 or 2), sensor rail (x1 or 2), mounting plates (x3), connectors (EE-1001 x3)
6	Photo sensor ¹ (x3)	EE-SX674 (OMRON Corporation)	Mounting screws, nuts, sensor dog (x1 or 2), sensor rail (x1 or 2), mounting plates (x3), connectors (EE-1001 x3)
7	Proximity sensor N.O. contact ² (x3)	APM-D3A1-001 (Azbil Corporation)	Mounting screws, nuts, sensor dog (x1 or 2), sensor rail (x1 or 2)
B	Proximity sensor N.C. contact ³ (x3)	APM-D3B1-003 (Azbil Corporation)	Mounting screws, nuts, sensor dog (x1 or 2), sensor rail (x1 or 2)
E	Proximity sensor N.O. contact ² (x1) N.C. contact ³ (x2)	APM-D3A1-001 (Azbil Corporation) APM-D3B1-003 (Azbil Corporation)	Mounting screws, nuts, sensor dog (x1 or 2), sensor rail (x1 or 2)
H	Proximity sensor N.O. contact ² (x3)	GX-F12A (Panasonic Industry Co., Ltd.)	Mounting screws, nuts, sensor dog (x1 or 2), sensor rail (x1 or 2)
L	Proximity sensor N.C. contact ³ (x3)	GX-F12B (Panasonic Industry Co., Ltd.)	Mounting screws, nuts, sensor dog (x1 or 2), sensor rail (x1 or 2)
J	Proximity sensor N.O. contact ² (x1) N.C. contact ³ (x2)	GX-F12A (Panasonic Industry Co., Ltd.) GX-F12B (Panasonic Industry Co., Ltd.)	Mounting screws, nuts, sensor dog (x1 or 2), sensor rail (x1 or 2)
M	Proximity sensor N.O. contact ² (x1) (PNP output) N.C. contact ³ (x2) (PNP output)	GX-F12A-P (Panasonic Industry Co., Ltd.) GX-F12B-P (Panasonic Industry Co., Ltd.)	Mounting screws, nuts, sensor dog (x1 or 2), sensor rail (x1 or 2)

¹ The photo sensors can be switched between ON when lit and ON when unlit.

² N.O. contact: Normally open contact point

³ N.C. contact: Normally closed contact point

Notes: 1. If proximity sensors are close to one another, they may not function properly. If that happens, please prepare a type with a different frequency.

2. Mounting of sensors other than those in the table above is possible. Contact THK for details.

Sensor Rail Mounting Dimensions

Mounting only a sensor rail is also possible.

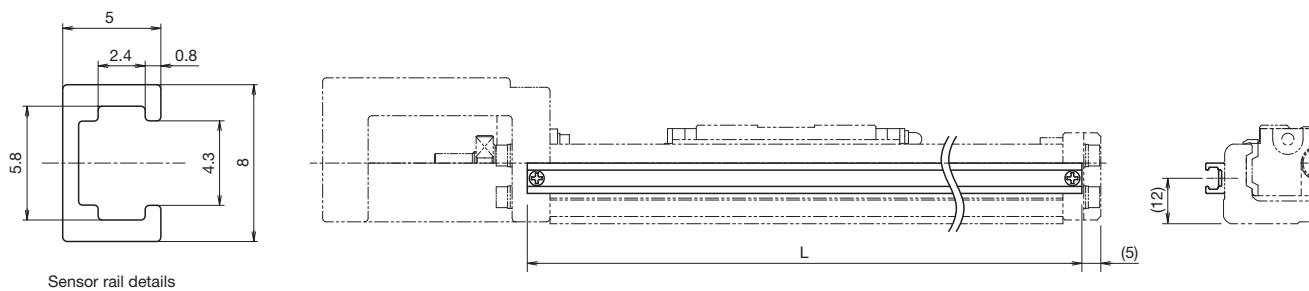

Stroke ⁴ (mm)	Outer rail length (mm)	L (mm)
60	150	161
110	200	211
160	250	261
210	300	311

⁴ Stroke with 1 block (A type).

Photo Sensor Mounting Dimensions

Connector: EE-1001 (OMRON Corporation) x3 included.
To be mounted by the customer.

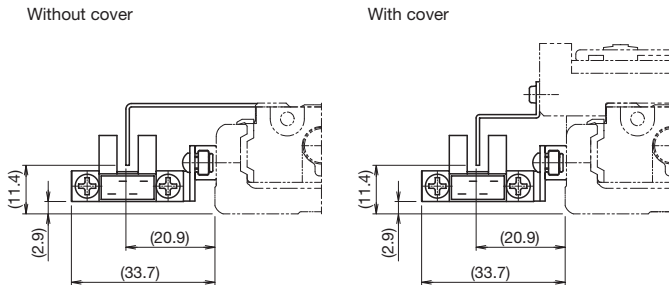

Symbol	Model	Manufacturer
2	EE-SX671	OMRON Corporation

Sensor dog width: 15 mm

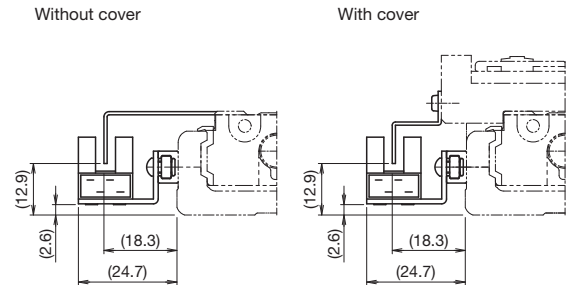

Symbol	Model	Manufacturer
6	EE-SX674	OMRON Corporation

Sensor dog width: 15 mm

Note: When selecting "2" for Model Number Coding ⑦ Cover, the above dimensions will differ. Contact THK for details.

Proximity Sensor Mounting Dimensions

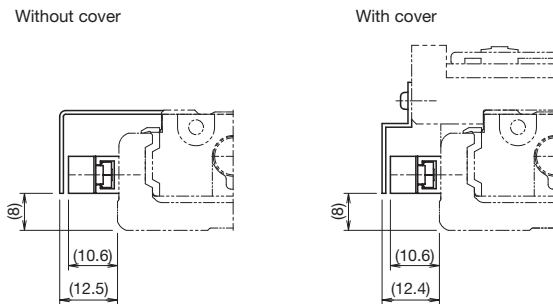

Symbol	Model	Manufacturer
7, B, E	APM-D3A1-001	Azbil Corporation
	APM-D3B1-003	

Sensor dog width: 15 mm

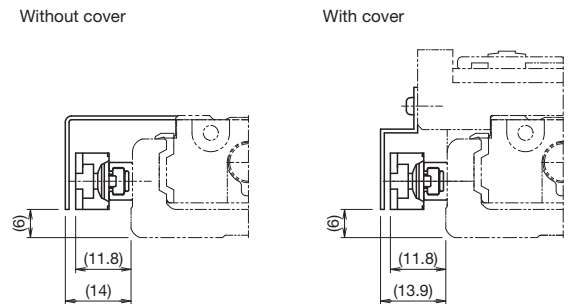

Symbol	Model	Manufacturer
H, L, J	GX-F12A	Panasonic Industry Co., Ltd.
	GX-F12B	
M	GX-F12A-P	
	GX-F12B-P	

Sensor dog width: 15 mm

Options

Intermediate Flange (Direct Coupling)

Several types of intermediate flanges for mounting motors are available.

When selecting "0" or "1" for Model Number Coding ⑥ With/without motor, specify an intermediate flange that matches the motor used.

Compatibility Table: Motors Used, Intermediate Flanges, and Couplings

Motor type	Manufacturer	Motor model		Motor rated output (W)	Flange size	Housing A/ Intermediate flange	Compatible coupling models		
							MIKI PULLEY CO., LTD.	Nabeya Bi-tech Kaisha (NBK)	
AC servo motor	YASKAWA Electric Corporation	Σ-Vmini	SGMMV-A1	10	25×25	AN	SFC-010DA2-5B-5B-L37	XGL2-15C-5-5	
			SGMMV-A2	20					
			SGMMV-A3	30					
		Σ-V	SGMJV-A5	50	40×40	AQ	SFC-010DA2-5B-8B-L32	XGT2-19C-5-8	
			SGMAV-A5						
		Σ-7	SGM7J-A5	50	40×40	AQ	SFC-010DA2-5B-8B-L32	XGT2-19C-5-8	
			SGM7A-A5						
		Σ-X	SGMXJ-A5	50	40×40	AQ	SFC-010DA2-5B-8B-L32	XGT2-19C-5-8	
	SGMXA-A5								
	Mitsubishi Electric Corporation	MELSERVO	J4	HG-AK0136	10	25×25	AN	SFC-010DA2-5B-5B-L37	XGL2-15C-5-5
				HG-AK0236	20				
				HG-AK0336	30				
			J5	HG-KR053	50	40×40	AQ	SFC-010DA2-5B-8B-L32	XGT2-19C-5-8
				HG-MR053					
				HK-KT053W					
	JN	HF-KN053	50	40×40	AQ	SFC-010DA2-5B-8B-L32	XGT2-19C-5-8		
	TAMAGAWA SEIKI CO., LTD.	TBL-III	TS4602	50	40×40	AQ	SFC-010DA2-5B-8B-L32	XGT2-19C-5-8	
		TBL-IV	TSM3102						
	Panasonic Corporation	MINAS	A5	MSMD5A	50	38×38	AP	SFC-010DA2-5B-8B-L32	XGT2-19C-5-8
				MSME5A					
A6			MSMF5A	50	38×38	AP	SFC-010DA2-5B-8B-L32	XGT2-19C-5-8	
			MHMF5A		40×40	AQ	SFC-010DA2-5B-8B-L32	XGT2-19C-5-8	
KEYENCE CORPORATION	SV	SV-M005	50	40×40	AQ	SFC-010DA2-5B-8B-L32	XGT2-19C-5-8		
	SV2	SV2-M005							
SANYO DENKI CO., LTD.	SANMOTION R	R2□A04005	50	40×40	AQ	SFC-010DA2-5B-8B-L32	XGT2-19C-5-8		
OMRON Corporation	OMNUC G5	R88M-K05030	50	40×40	AQ	SFC-010DA2-5B-8B-L32	XGT2-19C-5-8		
FANUC CORPORATION	β is Series	βis0.2/5000	50	40×40	AQ	SFC-010DA2-5B-8B-L32	XGT2-19C-5-8		

Motor type	Manufacturer	Motor model		Flange size	Housing A/ Intermediate flange	Compatible coupling models		
						MIKI PULLEY CO., LTD.	Nabeya Bi-tech Kaisha (NBK)	
Stepper motor	ORIENTAL MOTOR CO., LTD.	α step	AZ2*, AR2*	28×28	AS	SFC-010DA2-5B-5B-L39	XGL2-15C-5-5	
			AZ4*, AR4* (excluding AZM48)	42×42	AR	SFC-010DA2-5B-6B-L37	XGL2-15C-5-6	
			AZM48	42×42	AR	SFC-010DA2-5B-8B-L32	XGT2-19C-5-8	
		5-phase	CRK	CRK52*	28×28	AS	SFC-010DA2-5B-5B-L39	XGL2-15C-5-5
				CRK54*	42×42	AR	SFC-010DA2-5B-5B-L37	XGL2-15C-5-5
			RK II	RKS54*	42×42	AR	SFC-010DA2-5B-6B-L37	XGL2-15C-5-6
				PKP52*	28×28	AS	SFC-010DA2-5B-5B-L39	XGL2-15C-5-5
			PKP54*	42×42	AR	SFC-010DA2-5B-5B-L37	XGL2-15C-5-5	
		2-phase	PKP/CVD	PKP22*	28×28	AS	SFC-010DA2-5B-5B-L39	XGL2-15C-5-5
				PKP24*	42×42	AR	SFC-010DA2-5B-5B-L37	XGL2-15C-5-5
		KEYENCE CORPORATION	2-phase	QS-M28	28×28	AS	SFC-010DA2-5B-5B-L39	XGL2-15C-5-5
				QS-M42	42×42	AR	SFC-010DA2-5B-5B-L37	XGL2-15C-5-5
	SANYO DENKI CO., LTD.	PB	PBDM28*	28×28	AS	SFC-010DA2-5B-5B-L39	XGL2-15C-5-5	
			PBDM423, PBA**423	42×42	AR	SFC-010DA2-5B-6B-L37	XGL2-15C-5-6	
			FAF/FDF52*	28×28	AS	SFC-010DA2-5B-5B-L39	XGL2-15C-5-5	
		5-phase	FAF54*/FDF54*/FA511M42/FB511M42	42×42	AR	SFC-010DA2-5B-6B-L37	XGL2-15C-5-6	
			D*14S28*	28×28	AS	SFC-010DA2-5B-5B-L39	XGL2-15C-5-5	
		2-phase	DB14H52*	42×42	AR	SFC-010DA2-5B-5B-L37	XGT2-15C-5-5	
			DU15H52*					

- Notes: 1. The table shows only a portion of the model numbers for motors. For details regarding model numbers, please see the catalog for each respective motor manufacturer.
 2. If the maximum torque for motors exceeds the permissible input torque (p. 23), please consider a safety measure to limit the torque.
 3. When installing a motor other than the motor model numbers listed above, contact THK.

Housing A

SKR**	Actuator model
●◇	●: Housing A ◇: Intermediate flange

SKR26
A0

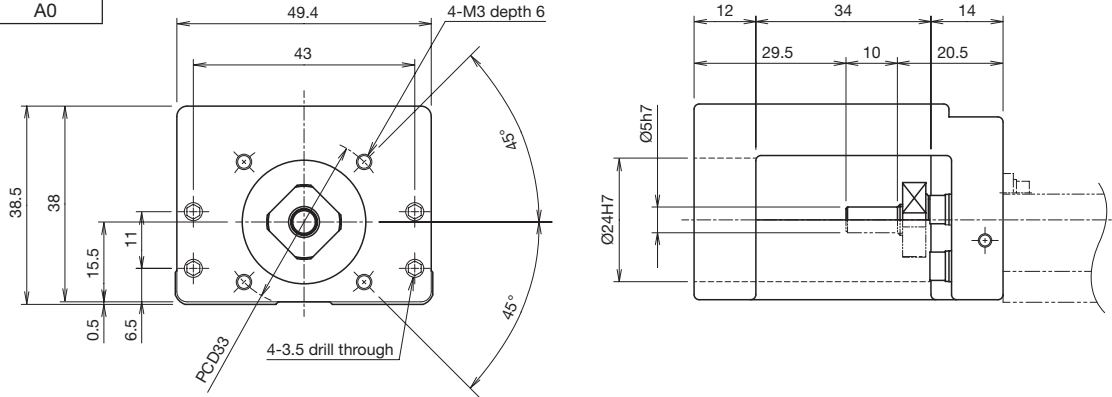

Intermediate Flange

SKR26
AP

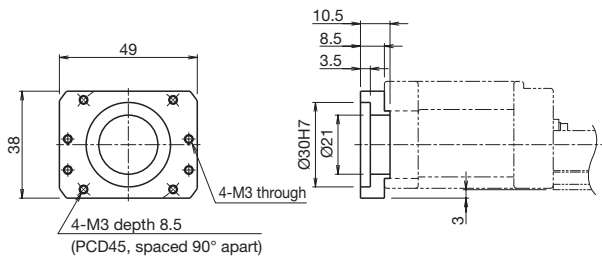

SKR26
AQ

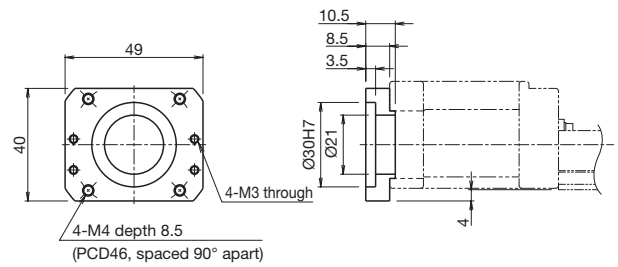

SKR26
AR

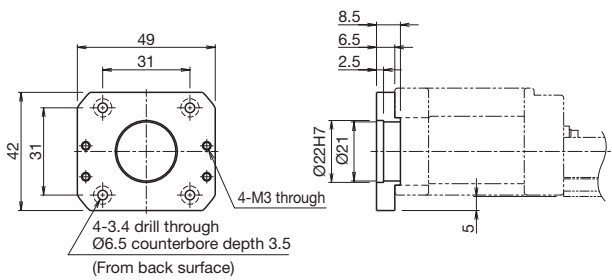

SKR26
AS

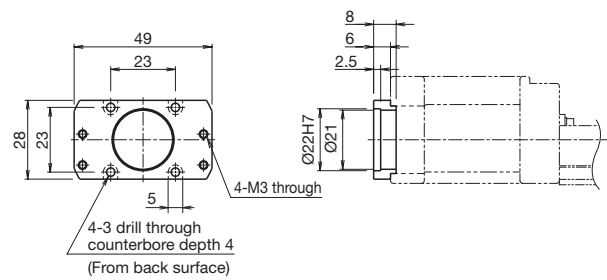

SKR26
AN

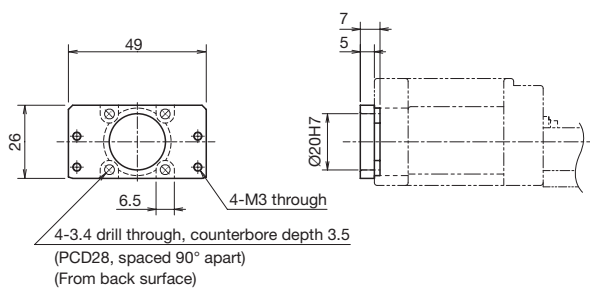

Options

Intermediate Flange (Motor Wrap)

Several types of intermediate flanges for mounting motors are available.

When selecting "R1," "R2," "R3," "R4," "R5," or "R6" for Model Number Coding ⑥ With/without motor, specify an intermediate flange that matches the motor used.

Symbol Coding

Motor wrap symbol ①	Intermediate flange ②	Motor shaft diameter (mm) ③	Motor shaft securing method ④
W	Q	08	D
W	Refer to the Compatibility Table: Motors Used and Motor Wrap Symbols below.	Specify a motor shaft diameter. (Refer to the Compatibility Table: Motors Used and Motor Wrap Symbols below.)	K: Key D: D-cut

Motor Shaft Securing Method

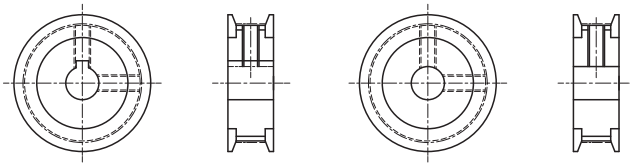

Key

D-cut

Compatibility Table: Motors Used and Motor Wrap Symbols

Motor type	Manufacturer	Motor model		Motor rated output (W)	Flange size	Housing A/Intermediate flange	
AC servo motor	YASKAWA Electric Corporation	Σ-Vmini	SGMMV-A1	10	25×25	WN-05D	
			SGMMV-A2	20			
			SGMMV-A3	30			
		Σ-V	SGMJV-A5	50	40×40	WQ-08K	
			SGMAV-A5				
			SGM7J-A5	50			40×40
		SGM7A-A5					
		Σ-7	SGMXJ-A5	50	40×40	WQ-08K	
	SGMXA-A5						
	Mitsubishi Electric Corporation	MELSERVO	J4	HG-AK0136	10	25×25	WN-05D
				HG-AK0236	20		
				HG-AK0336	30		
			J5	HG-MR053	50	40×40	WQ-08D
				HG-KR053			
				HK-KT053W			
		JN	HF-KN053	50	40×40	WQ-08D	
	TAMAGAWA SEIKI CO., LTD.	TBL-iii	TS4602	50	40×40	WQ-08D	
		TBL-iv	TSM3102				
	Panasonic Corporation	MINAS	A5	MSMD5A	50	38×38	WP-08D, WP-08K
				MSME5A			
A6			MSMF5A	50	38×38	WP-08K	
			MHMF5A		40×40	WQ-08K	
KEYENCE CORPORATION	SV	SV-M005	50	40×40	WQ-08K		
	SV2	SV2-M005					
SANYO DENKI CO., LTD.	SANMOTION R	R2□A04005	50	40×40	WQ-08K		
OMRON Corporation	OMNUC G5	R88M-K05030	50	40×40	WQ-08K		
FANUC CORPORATION	β is Series	βis0.2/5000	50	40×40	WQ-08K		

Notes: 1. The table shows only a portion of the model numbers for motors. For details regarding model numbers, please see the catalog for each respective motor manufacturer.
 2. If the maximum torque for motors exceeds the permissible input torque (p. 23), please consider a safety measure to limit the torque.
 3. When installing a motor other than the motor model numbers listed above, contact THK.

Motor Wrap Housing A

SKR26
20

SKR**	Actuator model
●◇	●: Housing A ◇: Intermediate flange

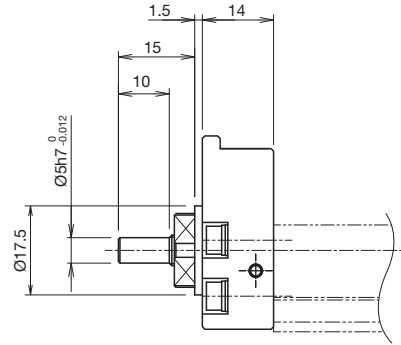
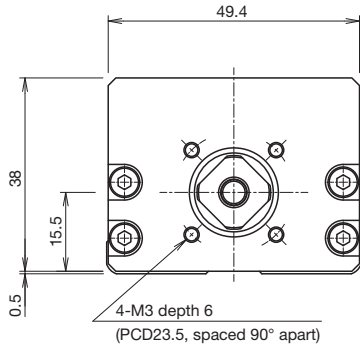

Note: The shaft end must be considered separately with motor wrap types.
Contact THK for details.

Motor Wrap Specification (Intermediate Flange)

SKR26
WP

SKR**	Actuator model
W□	□: Intermediate flange

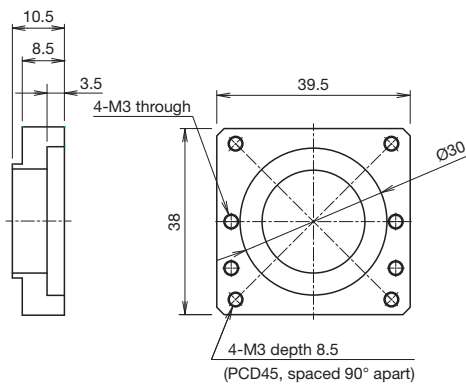

SKR26
WQ

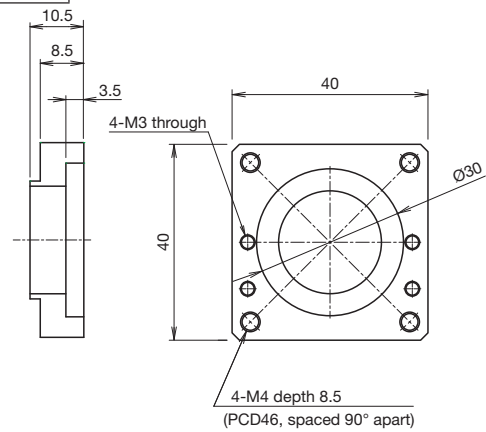

SKR26
WN

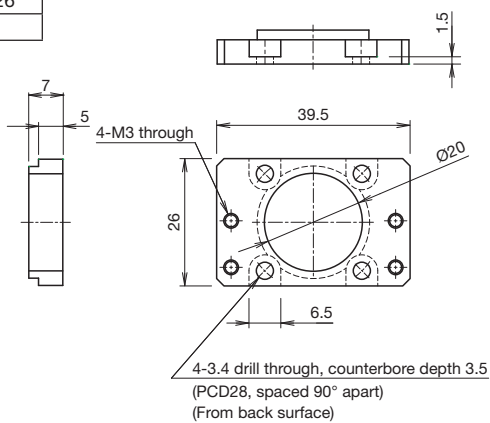

SKR33 A/B

Direct motor coupling	Motor wrap	Width 60 mm	Height 33 mm	Max. stroke 595 mm
-----------------------	------------	-------------	--------------	--------------------

Model Number Coding

Model	Ball screw lead	Block type	QZ specification	Stroke	Accuracy grade	With/without motor	Cover	Sensors	Housing A/ Intermediate flange	
①	②	③	④	⑤	⑥	⑦	⑧	⑨	⑩	
SKR33	06	A	QZA	0280	P	0	1	2	AQ	
SKR33	06: 6 mm 10: 10 mm 20: 20 mm	A: x1 B: x2	No symbol: Without QZ QZ QZA QZB QZAD	0045: 45 mm to 0595: 595 mm	No symbol: Normal grade H: High accuracy grade P: Precision grade	With direct coupling 0: Direct coupling (without motor) 1: Direct coupling (THK will purchase and mount the motor you specify.) With motor wrap R1: Non-standard side wrap (without motor) R2: Standard side wrap (without motor) R3: Bottom side wrap (without motor) R4: Non-standard side wrap (THK will purchase and mount the motor you specify.) R5: Standard side wrap (THK will purchase and mount the motor you specify.) R6: Bottom side wrap (THK will purchase and mount the motor you specify.)	0: Without cover 1: With cover 2: With bellows	0 1 2 6 7 B E H L J M	With direct coupling A0 AP AQ AR AT AU 40 With motor wrap WP-08D WP-08K WP-08M WQ-08D WQ-08K WQ-08M	
Check the stroke for type with QZ when selecting anything other than "No symbol." → p. 53 to p. 58				When selecting 2: With bellows for ⑧ Cover, specify the stroke with bellows. → p. 109 to p. 110		When selecting "0": A coupling is not provided. Indicate when placing an order if a coupling is required.		Sensor details → p. 47		With direct coupling → p. 49 With motor wrap → p. 51

③ Block Type

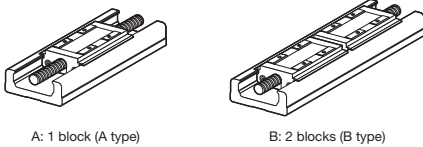

⑦ Motor Mounting Method

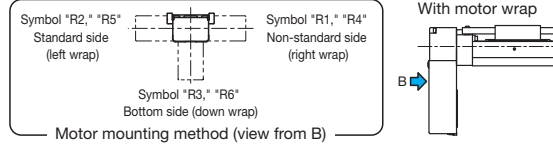

Selection Materials

Basic Specifications

LM Guide	Basic dynamic load rating C (N)		17,000		
	Basic static load rating C ₀ (N)		20,400		
	Radial clearance (mm)	Normal grade/High accuracy grade (H)	-0.004 to 0		
		Precision grade (P)	-0.012 to -0.004		
	Geometric moment of inertia	I _x ¹ (mm ⁴)	5.35×10 ⁴		
I _y ² (mm ⁴)		3.52×10 ⁵			
Mass (kg/m)		6.1			
Ball screw	Ball screw lead (mm)		6	10	20
	Basic dynamic load rating Ca (N)	Normal grade/High accuracy grade (H)	4,400	2,700	2,620
		Precision grade (P)			
	Basic static load rating C _{0a} (N)	Normal grade/High accuracy grade (H)	6,290	3,780	3,770
		Precision grade (P)			
	Screw shaft diameter (mm)		Ø13		
	Thread minor diameter (mm)		Ø10.8		
Ball center-to-center diameter (mm)		Ø13.5			
Permissible rotational speed ³ (min ⁻¹)	Normal grade/High accuracy grade (H)	6,000			
	Precision grade (P)				
Bearing (Fixed side)	Axial direction	Basic dynamic load rating Ca (N)	6,250		
		Static permissible load P _{0a} (N)	2,700		
Permissible input torque (N·m)	Direct coupling	2.8	3.2		
	Motor wrap		0.98		
Static permissible moment ^{4,5} (N·m)		M _A : 173 (990), M _B : 173 (990), M _C : 424 (848)			
Running life ⁶ (km)		5,000	10,000		
Standard grease/Grease nipple used		THK AFB-LF Grease/PB107			

¹ I_x is the geometric moment of inertia about the X axis.

² I_y is the geometric moment of inertia about the Y axis.

³ The permissible rotational speed may decrease as the stroke becomes longer.

⁴ The value in parentheses is with 2 blocks (B type) attached.

⁵ See p. 116 for the values if "1" or "2" is selected for item ⑧ in the Model Number Coding.

⁶ Calculated under the following conditions.

Stroke: 395 mm (A type), 320 mm (B type) / Speed: 300 mm/s (for 6 mm lead), 500 mm/s (for 10 mm lead), 1,000 mm/s (for 20 mm lead) / Load mass: Maximum load capacity (p. 9) / Acceleration/deceleration: As when set to maximum load capacity (p. 9) / Center of gravity: Center of the table's upper surface.

Notes: 1. Customized products can also be made to handle special environments or large axial loads (25% or more of the basic dynamic load rating Ca). Consult with THK.

2. LM Guide load rating is the load rating per block.

Accuracy

Accuracy grade	Item	Stroke ⁷						
		45	95	195	295	395	495	595
Normal grade (no symbol)	Positioning repeatability (mm)	±0.01						
	Positioning accuracy (mm)	Not specified						
	Running parallelism (vertical direction) (mm)	Not specified						
	Backlash (mm)	0.02						
	Starting torque (N·cm)	7						

Accuracy grade	Item	Stroke ⁷						
		45	95	195	295	395	495	595
High accuracy grade (H)	Positioning repeatability (mm)	±0.005						
	Positioning accuracy (mm)	0.06		0.1		0.12		
	Running parallelism (vertical direction) (mm)	0.025		0.035		0.04		
	Backlash (mm)	0.02						
	Starting torque (N·cm)	7						

Accuracy grade	Item	Stroke ⁷						
		45	95	195	295	395	495	595
Precision grade (P)	Positioning repeatability (mm)	±0.003						
	Positioning accuracy (mm)	0.02		0.025		0.03		
	Running parallelism (vertical direction) (mm)	0.01		0.015		0.02		
	Backlash (mm)	0.003						
	Starting torque (N·cm)	15						

⁷ Stroke with 1 block (A type, without QZ).

Notes: 3. Precision evaluation in accordance with THK standards.

4. Measured using a motor for inspection. With motor wrap specifications, measurements are not made in the completed motor wrap state.

5. The starting torque represents the value when containing THK AFB-LF Grease.

6. The starting torque may exceed standards if using vacuum grease, clean room grease, or other high-viscosity greases, so care should be taken when selecting a motor.

7. Contact THK for accuracy higher than the standard stroke.

Geometric Moment of Inertia

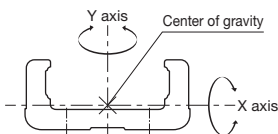

Static Permissible Moment

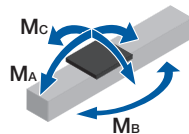

Motor Selection Information

Stroke ¹ (mm)	Outer rail length (mm)	LM Guide				Ball screw		Motor mounting part	
		Moving part mass (kg)			Sliding resistance value ² (N)	Lead (mm)	Shaft length (mm)	Direct coupling	Motor wrap
		Block mass	Sub-table mass	Total mass				Shaft end diameter (mm)	Timing pulley (sum of two) Inertial moment x 10 ⁻⁴ (kg·m ²)
45 to 595	150 to 700	A type: 0.4 B type: 0.8	A type: 0.2 B type: 0.4	A type: 0.6 B type: 1.2	4.7	6, 10, 20	198 to 748	Ø8h7	0.041

¹ Stroke with 1 block (A type, without QZ).

² Value with 1 block (A type, without QZ). This value is the sum of the rolling resistance value and seal resistance value.

Note: Refer to p. 49 for applicable couplings.

Permissible Overhang Length³

Horizontal

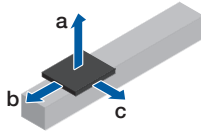

Wall-Mounted

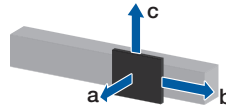

Vertical

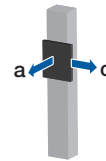

Estimated motor capacity 100 W	Ball screw lead (mm)	Load mass (kg)	a (mm)	b (mm)	c (mm)	
Direct coupling	A type	6	10.5	430	130	180
			21.5	190	60	90
			43.5	80	30	40
		10	8.5	540	170	230
			17	250	80	110
			34.5	110	40	50
	B type	6	3	600	430	600
			6	600	210	320
			12.5	360	100	150
		10	15	600	430	260
			30.5	600	210	120
			61.5	330	100	60
Motor wrap	A type	6	8.5	600	600	460
			17	600	380	230
			34	600	190	110
		10	2.5	600	600	600
			5.5	600	240	350
			11	410	110	170
	B type	6	15	600	430	260
			30.5	600	210	120
			61.5	330	100	60
		10	8.5	600	600	460
			17	600	380	230
			34	600	190	110
20	6	2.5	600	600	600	
		5.5	600	600	600	
		11	600	590	350	

Estimated motor capacity 100 W	Ball screw lead (mm)	Load mass (kg)	a (mm)	b (mm)	c (mm)	
Direct coupling	A type	6	8.5	200	150	500
			17.5	80	70	240
			35	20	30	120
		10	7.5	230	170	560
			15	100	80	280
			30	30	30	140
	B type	6	3	600	420	600
			6	290	200	600
			12.5	120	90	340
		10	12	290	290	600
			24.5	130	140	480
			49	40	70	240
Motor wrap	A type	6	8.5	430	420	600
			17	200	210	600
			34	80	100	350
		10	2.5	600	600	600
			5.5	600	600	600
			11	320	320	600
	B type	6	8.5	200	150	500
			17.5	80	70	240
			35	20	30	120
		10	7.5	230	170	560
			15	100	80	280
			30	30	30	140
20	6	2.5	600	480	600	
		5.5	320	230	600	
		11	140	100	380	
	10	12	290	290	600	
		24.5	130	140	480	
		49	40	70	240	

Estimated motor capacity 100 W	Ball screw lead (mm)	Load mass (kg)	a (mm)	c (mm)	
Direct coupling	A type	6	4.5	220	210
			9.5	90	100
			19	30	50
		10	3	340	320
			6	160	160
			12	60	80
	B type	6	1	600	600
			2.5	420	390
			5.5	170	170
		10	5.5	600	490
			11	430	240
			22	200	120
Motor wrap	A type	6	3	600	600
			6	600	450
			12.5	380	210
		10	1	600	600
			2.5	530	490
			4.5	220	210
	B type	6	5.5	600	490
			11	430	240
			22	200	120
		10	3	600	600
			6	600	450
			12.5	380	210
20	6	1	600	600	
		2.5	600	600	
		5	600	540	
	10	4.5	220	210	
		9.5	90	100	
		19	30	50	

³ This is the value with the service life of the LM Guide limited to 10,000 km (5,000 km for 6 mm lead only). The calculation conditions are as follows.

Stroke: 320 mm (A type, B type) / Acceleration/deceleration: 0.3 G / Speed: 300 mm/s (for 6 mm lead), 500 mm/s (for 10 mm lead), 1,000 mm/s (for 20 mm lead) / Overhang direction: Loaded in only a single direction. Dimensions a, b, and c are from the center of the table's upper surface.

With Cover
Direct Motor Coupling

Dimensions

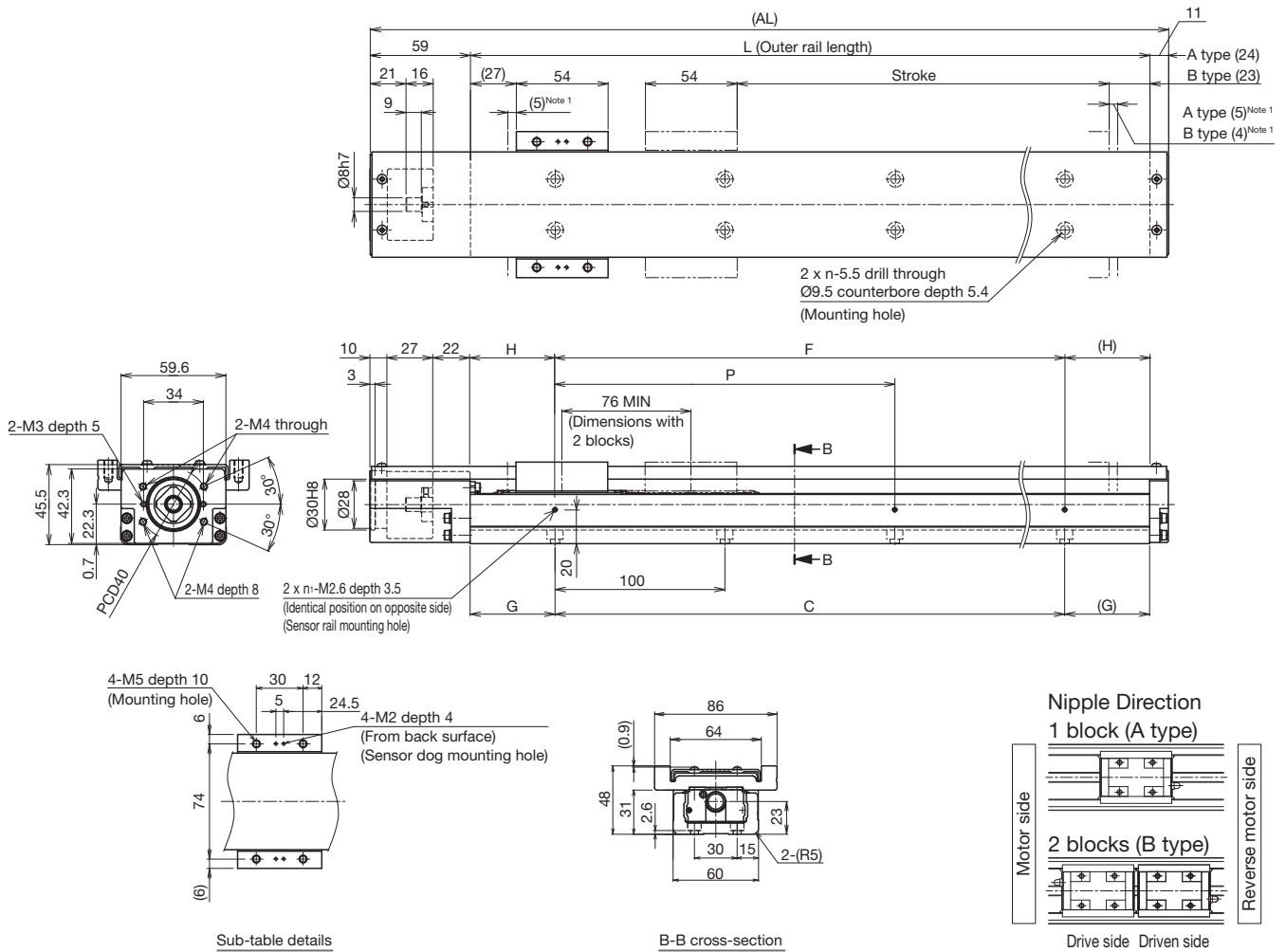

¹ Dimensions from the mechanical stopper to the stroke start position.

Stroke (mm) (Stroke between mechanical stoppers)	A type	45 (55)	95 (105)	195 (205)	295 (305)	395 (405)	495 (505)	595 (605)
	B type ²	-	-	120 (129)	220 (229)	320 (329)	420 (429)	520 (529)
Maximum speed ³ (mm/s)	Ball screw lead: 6 mm	600					550	390
	Ball screw lead: 10 mm	1,000					920	650
	Ball screw lead: 20 mm	2,000					1,780	1,270
Dimensions (mm)	AL	220	270	370	470	570	670	770
	L	150	200	300	400	500	600	700
	C	100	100	200	300	400	500	600
	G	25	50	50	50	50	50	50
	P	100	100	200	200	200	200	200
	F	100	100	200	200	400	400	600
	H	25	50	50	100	50	100	50
No. of mounting holes	n	2	2	3	4	5	6	7
	n _i	2	2	2	2	3	3	4
Mass ⁴ (kg)		2.3	2.6	3.4	4.2	4.9	5.7	6.4

² The value with 2 blocks (B type, without QZ) attached.

³ The maximum speed is restricted by the actuator's permissible speed.

⁴ The mass with 2 blocks (B type) has 0.6 kg added.

Without Cover
Direct Motor Coupling

Dimensions

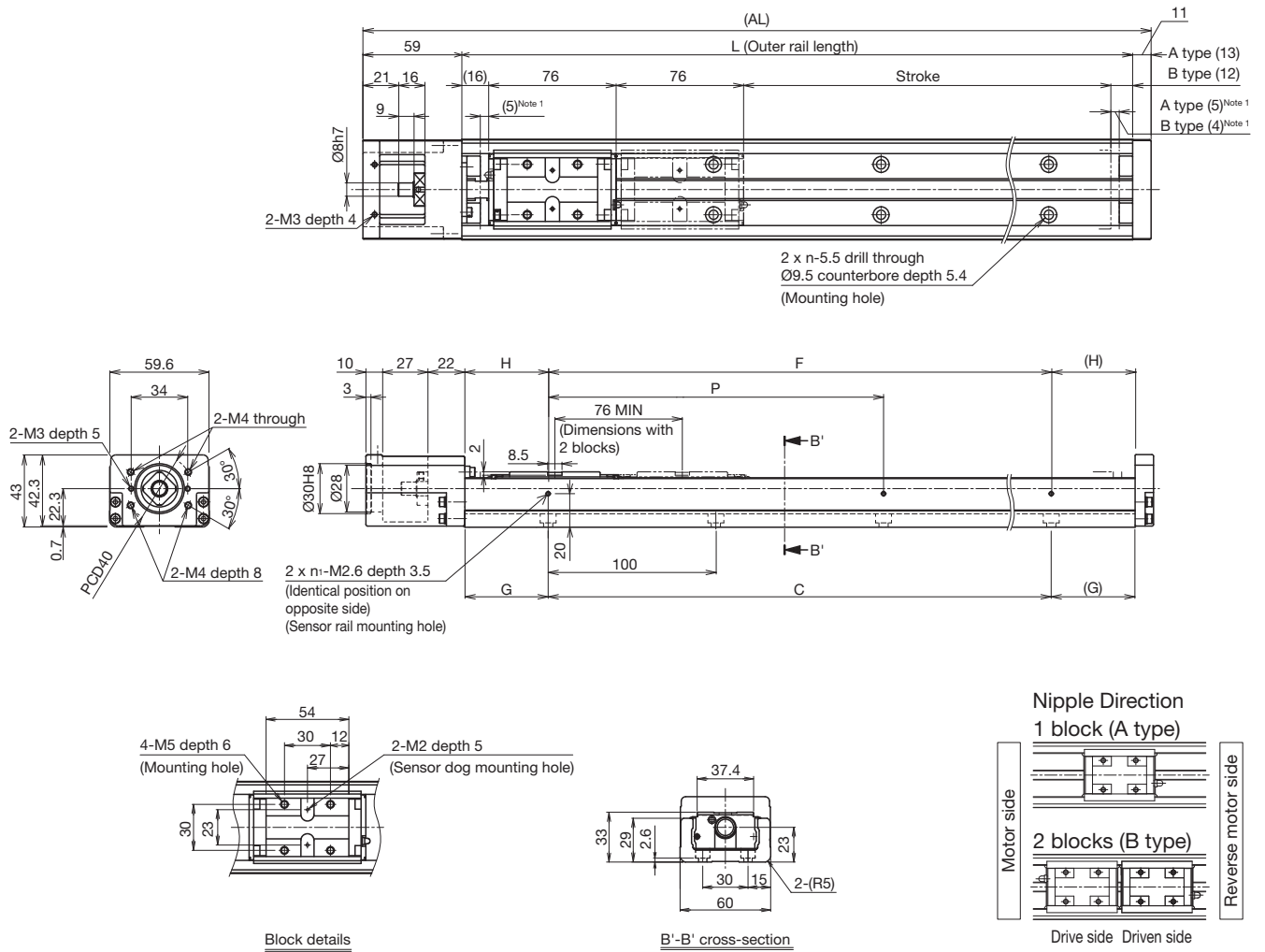

¹ Dimensions from the mechanical stopper to the stroke start position.

Stroke (mm) (Stroke between mechanical stoppers)	A type	45 (55)	95 (105)	195 (205)	295 (305)	395 (405)	495 (505)	595 (605)	
	B type ²	-	-	120 (129)	220 (229)	320 (329)	420 (429)	520 (529)	
Maximum speed ³ (mm/s)	Ball screw lead: 6 mm	600						550	390
	Ball screw lead: 10 mm	1,000						920	650
	Ball screw lead: 20 mm	2,000						1,780	1,270
Dimensions (mm)	AL	220	270	370	470	570	670	770	
	L	150	200	300	400	500	600	700	
	C	100	100	200	300	400	500	600	
	G	25	50	50	50	50	50	50	
	P	100	100	200	200	200	200	200	
	F	100	100	200	200	400	400	600	
	H	25	50	50	100	50	100	50	
No. of mounting holes	n	2	2	3	4	5	6	7	
	n ₁	2	2	2	2	3	3	4	
Mass ⁴ (kg)		1.9	2.3	3	3.7	4.5	5.2	5.9	

² The value with 2 blocks (B type, without QZ) attached.

³ The maximum speed is restricted by the actuator's permissible speed.

⁴ The mass with 2 blocks (B type) has 0.4 kg added.

With Cover
Motor Wrap

Dimensions

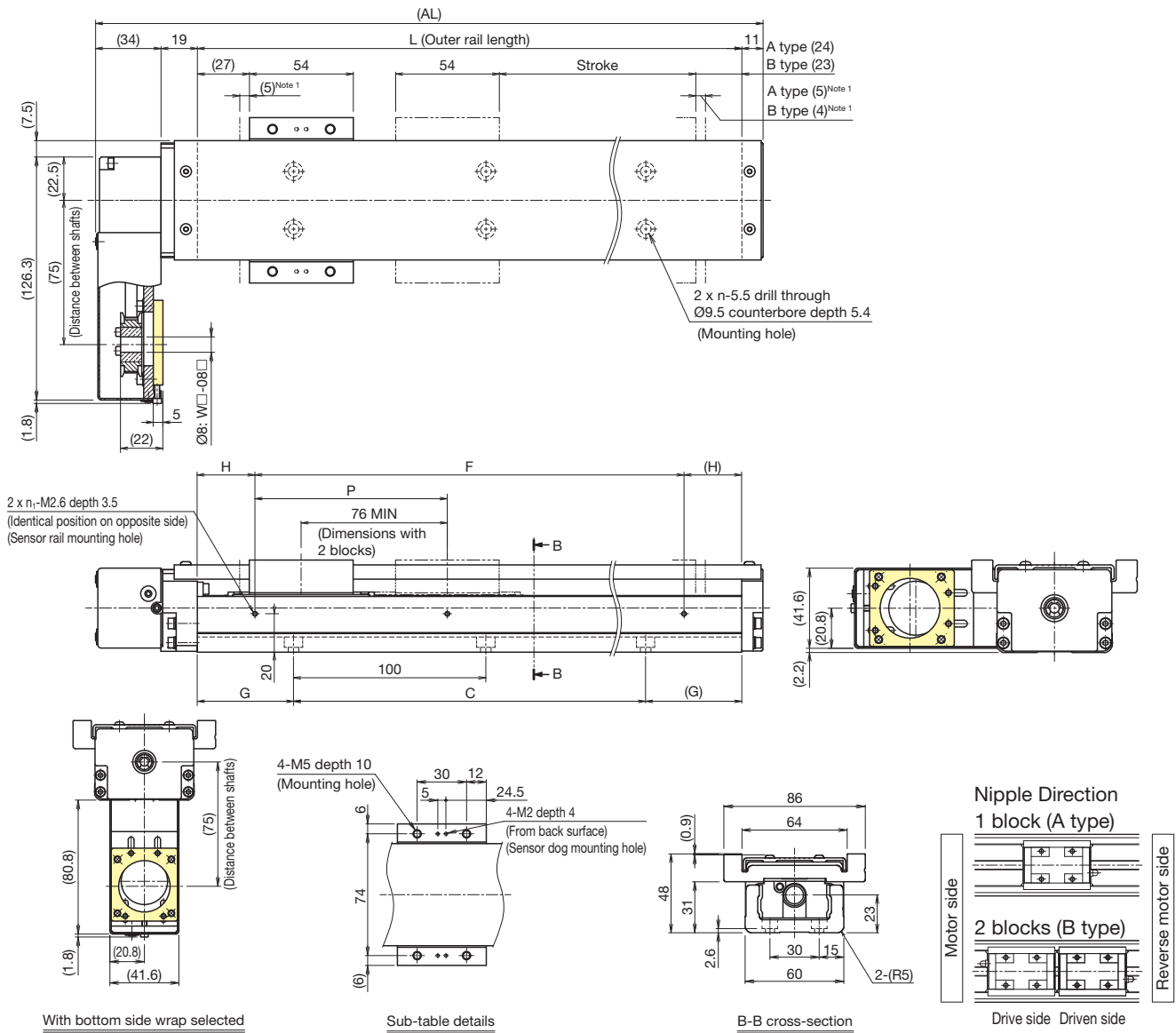

¹ Dimensions from the mechanical stopper to the stroke start position.

Stroke (mm) (Stroke between mechanical stoppers)	A type	45 (55)	95 (105)	195 (205)	295 (305)	395 (405)	495 (505)	595 (605)
	B type ²	-	-	120 (129)	220 (229)	320 (329)	420 (429)	520 (529)
Maximum speed ³ (mm/s)	Ball screw lead: 6 mm			600			550	390
	Ball screw lead: 10 mm			1,000			920	650
	Ball screw lead: 20 mm			2,000			1,780	1,270
Dimensions (mm)	AL	214	264	364	464	564	664	764
	L	150	200	300	400	500	600	700
	C	100	100	200	300	400	500	600
	G	25	50	50	50	50	50	50
	P	100	100	200	200	200	200	200
	F	100	100	200	200	400	400	600
No. of mounting holes	n	2	2	3	4	5	6	7
	n ₁	2	2	2	2	3	3	4
Mass ⁴ (kg)		2.5	2.9	3.7	4.4	5.2	6	6.7

² The value with 2 blocks (B type, without QZ) attached.

³ The maximum speed is restricted by the actuator's permissible speed.

⁴ The mass with 2 blocks (B type) has 0.6 kg added.

Without Cover
Motor Wrap

Dimensions

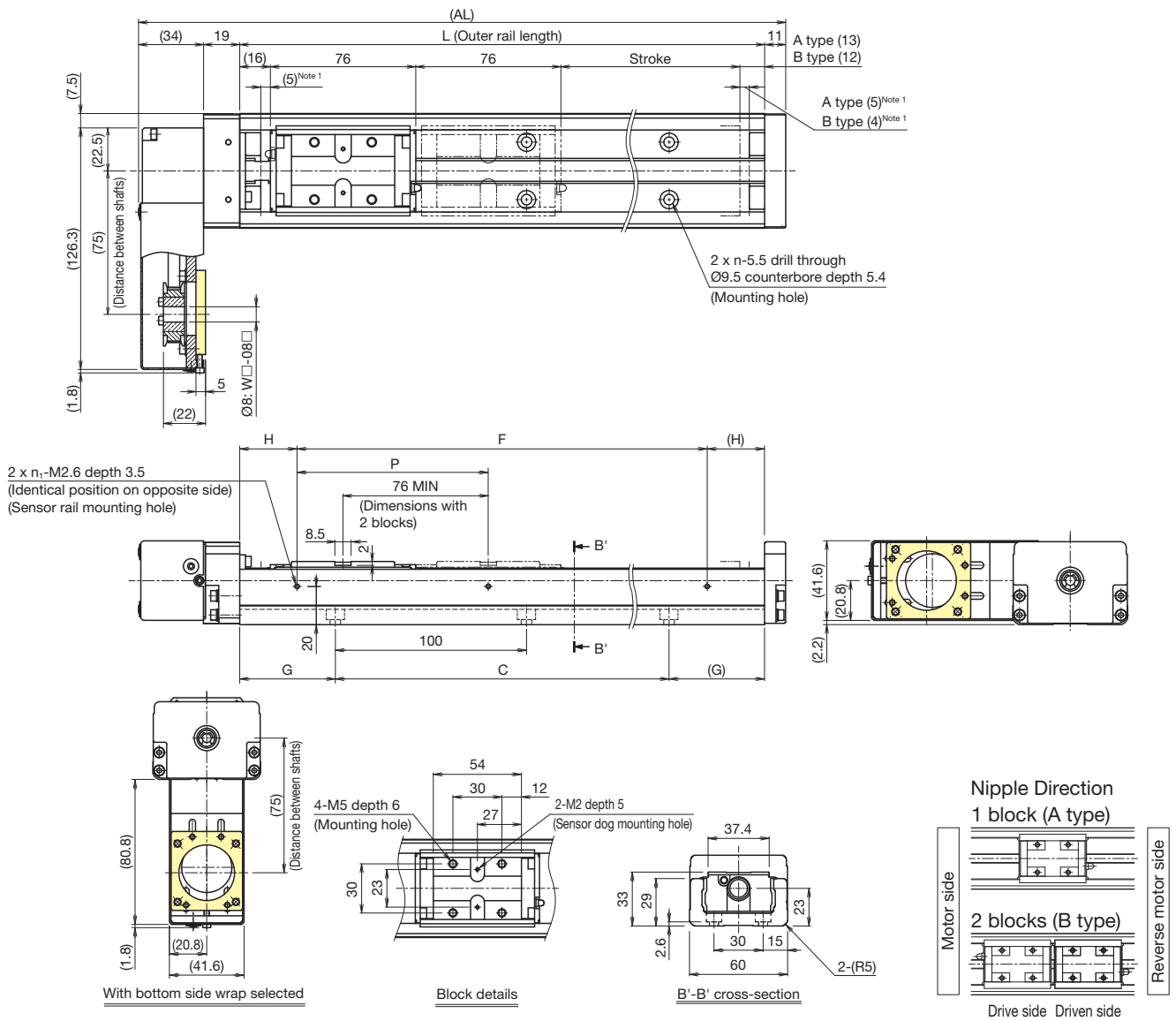

¹ Dimensions from the mechanical stopper to the stroke start position.

Stroke (mm) (Stroke between mechanical stoppers)	A type	45 (55)	95 (105)	195 (205)	295 (305)	395 (405)	495 (505)	595 (605)
	B type ²	-	-	120 (129)	220 (229)	320 (329)	420 (429)	520 (529)
Maximum speed ³ (mm/s)	Ball screw lead: 6 mm			600			550	390
	Ball screw lead: 10 mm			1,000			920	650
	Ball screw lead: 20 mm			2,000			1,780	1,270
Dimensions (mm)	AL	214	264	364	464	564	664	764
	L	150	200	300	400	500	600	700
	C	100	100	200	300	400	500	600
	G	25	50	50	50	50	50	50
	P	100	100	200	200	200	200	200
	F	100	100	200	200	400	400	600
No. of mounting holes	n	2	2	3	4	5	6	7
	n ₁	2	2	2	2	3	3	4
Mass ⁴ (kg)		2.2	2.6	3.3	4	4.8	5.5	6.2

² The value with 2 blocks (B type, without QZ) attached.

³ The maximum speed is restricted by the actuator's permissible speed.

⁴ The mass with 2 blocks (B type) has 0.4 kg added.

SKR33 C/D

Direct motor coupling	Motor wrap	Width 60 mm	Height 33 mm	Max. stroke 620 mm
-----------------------	------------	-------------	--------------	--------------------

Model Number Coding

Model	Ball screw lead	Block type	QZ specification	Stroke	Accuracy grade	With/without motor	Cover	Sensors	Housing A/ Intermediate flange
①	②	③	④	⑤	⑥	⑦	⑧	⑨	⑩
SKR33	06	C	QZA	0305	P	0	1	2	AQ
SKR33	06: 6 mm 10: 10 mm	C: x1 D: x2	No symbol: Without QZ QZ QZA QZB QZAD	0020: 20 mm to 0620: 620 mm When selecting 2: With bellows for ⑧ Cover, specify the stroke with bellows. → p. 111 to p. 112	No symbol: Normal grade H: High accuracy grade P: Precision grade	With direct coupling 0: Direct coupling (without motor) With motor wrap R1: Non-standard side wrap (without motor) R2: Standard side wrap (without motor) R3: Bottom side wrap (without motor) R4: Non-standard side wrap (THK will purchase and mount the motor you specify.) R5: Standard side wrap (THK will purchase and mount the motor you specify.) R6: Bottom side wrap (THK will purchase and mount the motor you specify.) When selecting "0": A coupling is not provided. Indicate when placing an order if a coupling is required. When selecting "1," "R4," "R5," or "R6": The specified motor will be installed. Indicate the motor cable direction separately. Select ⑩ Intermediate flange to match the specified motor.	0: Without cover 1: With cover 2: With bellows	0 1 2 6 7 B E H L J M Sensor details → p. 47	With direct coupling A0 AP AQ AR AT AU 40 With motor wrap WP-08D WP-08K WP-08M WQ-08D WQ-08K WQ-08M With direct coupling → p. 49 With motor wrap → p. 51

③ Block Type

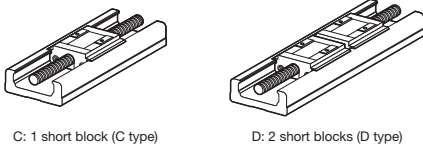

⑦ Motor Mounting Method

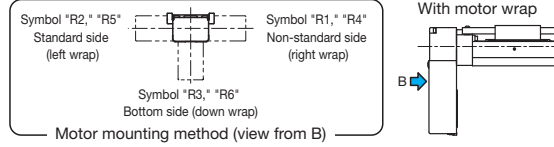

Selection Materials

Basic Specifications

LM Guide	Basic dynamic load rating C (N)		11,300
	Basic static load rating C ₀ (N)		11,500
	Radial clearance (mm)	Normal grade/High accuracy grade (H)	-0.004 to 0
		Precision grade (P)	-0.012 to -0.004
	Geometric moment of inertia	I _x ¹ (mm ⁴)	5.35×10 ⁴
I _y ² (mm ⁴)		3.52×10 ⁵	
Mass (kg/m)		6.1	
Ball screw	Ball screw lead (mm)		6 10
	Basic dynamic load rating Ca (N)	Normal grade/High accuracy grade (H)	4,400 2,700
		Precision grade (P)	
	Basic static load rating C _{0a} (N)	Normal grade/High accuracy grade (H)	6,290 3,780
		Precision grade (P)	
	Screw shaft diameter (mm)		Ø13
	Thread minor diameter (mm)		Ø10.8
Ball center-to-center diameter (mm)		Ø13.5	
Permissible rotational speed ³ (min ⁻¹)	Normal grade/High accuracy grade (H)	6,000	
	Precision grade (P)		
Bearing (Fixed side)	Axial direction	Basic dynamic load rating Ca (N)	6,250
		Static permissible load P _{0a} (N)	2,700
Permissible input torque (N·m)	Direct coupling	2.8	3.2
	Motor wrap	0.98	
Static permissible moment ^{4,5} (N·m)		M _A : 58 (390), M _B : 58 (390), M _C : 240 (480)	
Running life ⁶ (km)		5,000	10,000
Standard grease/Grease nipple used		THK AFB-LF Grease/PB107	

¹ I_x is the geometric moment of inertia about the X axis.
² I_y is the geometric moment of inertia about the Y axis.
³ The permissible rotational speed may decrease as the stroke becomes longer.
⁴ The value in parentheses is with 2 short blocks (D type) attached.
⁵ See p. 116 for the values if "1" or "2" is selected for item ⑧ in the Model Number Coding.
⁶ Calculated under the following conditions.
 Stroke: 420 mm (C type), 370 mm (D type) / Speed: 300 mm/s (for 6 mm lead), 500 mm/s (for 10 mm lead), 1,000 mm/s (for 20 mm lead) / Load mass: Maximum load capacity (p. 9) / Acceleration/deceleration: As when set to maximum load capacity (p. 9) / Center of gravity: Center of the table's upper surface.
 Notes: 1. Customized products can also be made to handle special environments or large axial loads (25% or more of the basic dynamic load rating Ca). Consult with THK.
 2. LM Guide load rating is the load rating per short block.

Accuracy

Accuracy grade	Item	Stroke ⁷						
		70	120	220	320	420	520	620
Normal grade (no symbol)	Positioning repeatability (mm)	±0.01						
	Positioning accuracy (mm)	Not specified						
	Running parallelism (vertical direction) (mm)	Not specified						
	Backlash (mm)	0.02						
	Starting torque (N·cm)	7						
High accuracy grade (H)	Positioning repeatability (mm)	±0.005						
	Positioning accuracy (mm)	0.06		0.1		0.12		
	Running parallelism (vertical direction) (mm)	0.025		0.035		0.04		
	Backlash (mm)	0.02						
	Starting torque (N·cm)	7						
Precision grade (P)	Positioning repeatability (mm)	±0.003						
	Positioning accuracy (mm)	0.02		0.025		0.03		
	Running parallelism (vertical direction) (mm)	0.01		0.015		0.02		
	Backlash (mm)	0.003						
	Starting torque (N·cm)	15						

⁷ Stroke with 1 short block (C type, without QZ).
 Notes: 3. Precision evaluation in accordance with THK standards.
 4. Measured using a motor for inspection. With motor wrap specifications, measurements are not made in the completed motor wrap state.
 5. The starting torque represents the value when containing THK AFB-LF Grease.
 6. The starting torque may exceed standards if using vacuum grease, clean room grease, or other high-viscosity greases, so care should be taken when selecting a motor.
 7. Contact THK for accuracy higher than the standard stroke.

Geometric Moment of Inertia

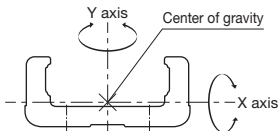

Static Permissible Moment

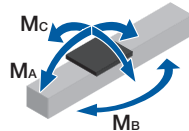

Motor Selection Information

Stroke ¹ (mm)	Outer rail length (mm)	LM Guide				Ball screw		Motor mounting part	
		Moving part mass (kg)			Sliding resistance value ² (N)	Lead (mm)	Shaft length (mm)	Direct coupling	Motor wrap
		Block mass	Sub-table mass	Total mass				Shaft end diameter (mm)	Timing pulley (sum of two) Inertial moment x 10 ⁻⁴ (kg·m ²)
70 to 620	150 to 700	C type: 0.2 D type: 0.4	C type: 0.1 D type: 0.2	C type: 0.3 D type: 0.6	3.8	6, 10	198 to 748	Ø8h7	0.041

¹ Stroke with 1 short block (C type, without QZ).

² Value with 1 short block (C type, without QZ). This value is the sum of the rolling resistance value and seal resistance value.

Note: Refer to p. 49 for applicable couplings.

Permissible Overhang Length³

Horizontal

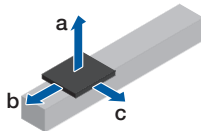

Wall-Mounted

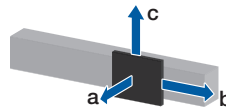

Vertical

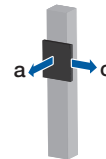

Estimated motor capacity 100 W	Ball screw lead (mm)	Load mass (kg)	a	b	c	
			(mm)	(mm)	(mm)	
Direct coupling	C type	6	7.5	110	40	80
			15.5	40	10	40
			31.5	0	0	20
		10	6.5	130	40	100
			13.5	50	20	40
	D type	6	27	10	10	20
			11	600	190	170
			22	290	90	80
		10	44.5	130	40	40
			8.5	600	240	230
Motor wrap	C type	6	7.5	110	40	80
			15.5	40	10	40
			31.5	0	0	20
		10	6.5	130	40	100
			13.5	50	20	40
	D type	6	27	10	10	20
			11	600	190	170
			22	290	90	80
		10	44.5	130	40	40
			8.5	600	240	230
Direct coupling	C type	6	7.5	110	40	80
			15.5	40	10	40
			31.5	0	0	20
		10	6.5	130	40	100
			13.5	50	20	40
	D type	6	27	10	10	20
			11	600	190	170
			22	290	90	80
		10	44.5	130	40	40
			8.5	600	240	230
Motor wrap	C type	6	7.5	110	40	80
			15.5	40	10	40
			31.5	0	0	20
		10	6.5	130	40	100
			13.5	50	20	40
	D type	6	27	10	10	20
			11	600	190	170
			22	290	90	80
		10	44.5	130	40	40
			8.5	600	240	230

Estimated motor capacity 100 W	Ball screw lead (mm)	Load mass (kg)	a	b	c	
			(mm)	(mm)	(mm)	
Direct coupling	C type	6	6	70	70	240
			12.5	20	30	110
			25	0	10	50
		10	5	90	80	290
			10	30	40	140
	D type	6	20.5	0	20	70
			8.5	200	170	570
			17.5	80	80	270
		10	35.5	20	40	130
			7.5	230	190	600
Motor wrap	C type	6	6	70	70	240
			12.5	20	30	110
			25	0	10	50
		10	5	90	80	290
			10	30	40	140
	D type	6	20.5	0	20	70
			8.5	200	170	570
			17.5	80	80	270
		10	35.5	20	40	130
			7.5	230	190	600

Estimated motor capacity 100 W	Ball screw lead (mm)	Load mass (kg)	a	c	
			(mm)	(mm)	
Direct coupling	C type	6	2.5	60	130
			5	20	60
			10.5	0	30
		10	2	90	170
			4	30	80
	D type	6	8.5	0	40
			4.5	330	250
			9.5	140	110
		10	19	60	50
			3	510	370
Motor wrap	C type	6	2.5	60	130
			5	20	60
			10.5	0	30
		10	2	90	170
			4	30	80
	D type	6	8.5	0	40
			4.5	330	250
			9.5	140	110
		10	19	60	50
			3	510	370

³ This is the value with the service life of the LM Guide limited to 10,000 km (5,000 km for 6 mm lead only). The calculation conditions are as follows.

Stroke: 345 mm (C type), 295 mm (D type) / Acceleration/deceleration: 0.3 G / Speed: 300 mm/s (for 6 mm lead), 500 mm/s (for 10 mm lead), 1,000 mm/s (for 20 mm lead) / Overhang direction: Loaded in only a single direction. Dimensions a, b, and c are from the center of the table's upper surface.

With Cover
Direct Motor Coupling

Dimensions

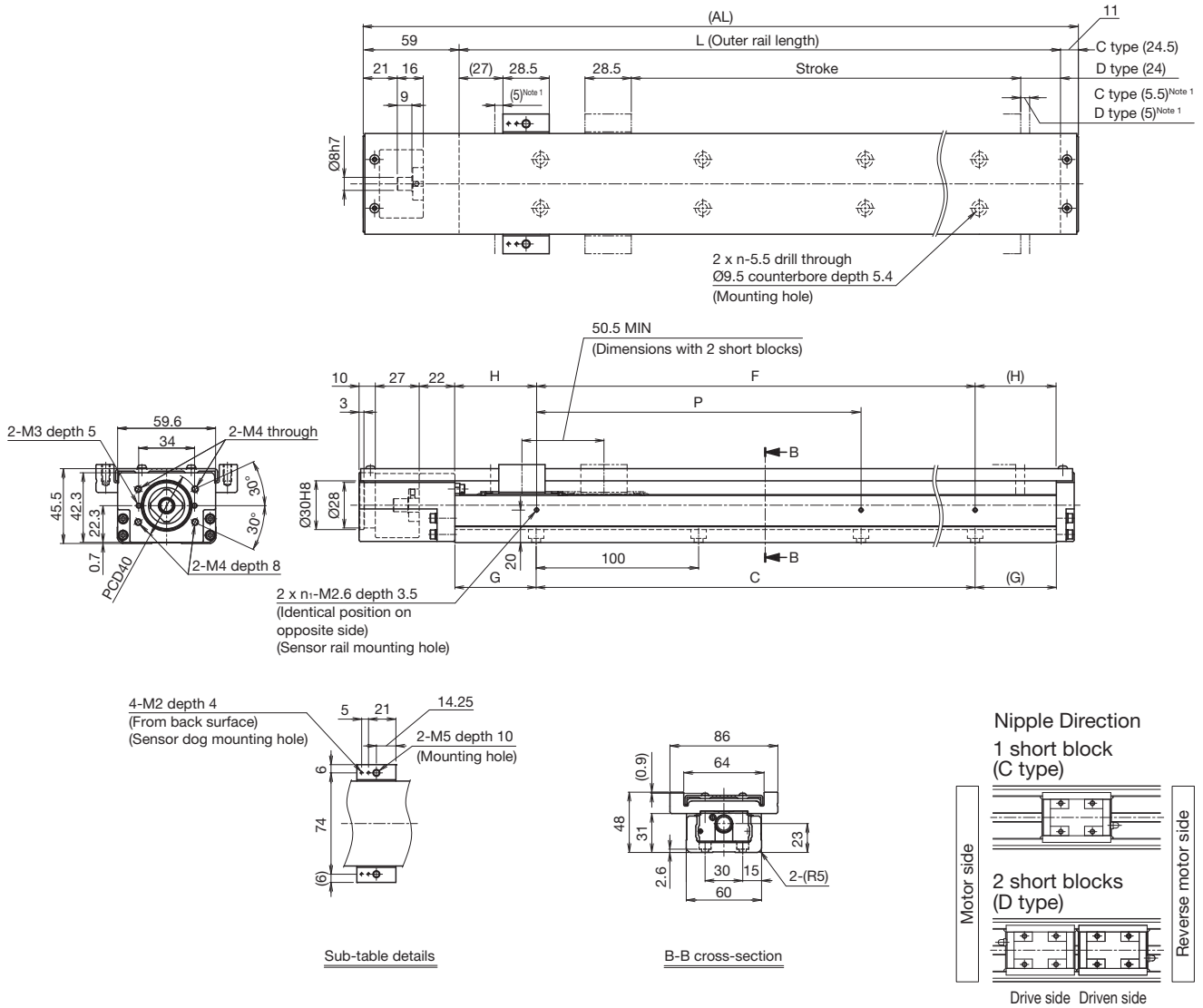

¹ Dimensions from the mechanical stopper to the stroke start position.

Stroke (mm) (Stroke between mechanical stoppers)	C type	70 (80.5)	120 (130.5)	220 (230.5)	320 (330.5)	420 (430.5)	520 (530.5)	620 (630.5)
	D type ²	20 (30)	70 (80)	170 (180)	270 (280)	370 (380)	470 (480)	570 (580)
Maximum speed ³ (mm/s)	Ball screw lead: 6 mm			600			500	360
	Ball screw lead: 10 mm			1,000			830	600
Dimensions (mm)	AL	220	270	370	470	570	670	770
	L	150	200	300	400	500	600	700
	C	100	100	200	300	400	500	600
	G	25	50	50	50	50	50	50
	P	100	100	200	200	200	200	200
	F	100	100	200	200	400	400	600
	H	25	50	50	100	50	100	50
No. of mounting holes	n	2	2	3	4	5	6	7
	n _i	2	2	2	2	3	3	4
Mass ⁴ (kg)		2	2.3	3.1	3.9	4.6	5.4	6.1

² The value with 2 short blocks (D type, without QZ) attached.

³ The maximum speed is restricted by the actuator's permissible speed.

⁴ The mass with 2 short blocks (D type) has 0.3 kg added.

Without Cover
Direct Motor Coupling

Dimensions

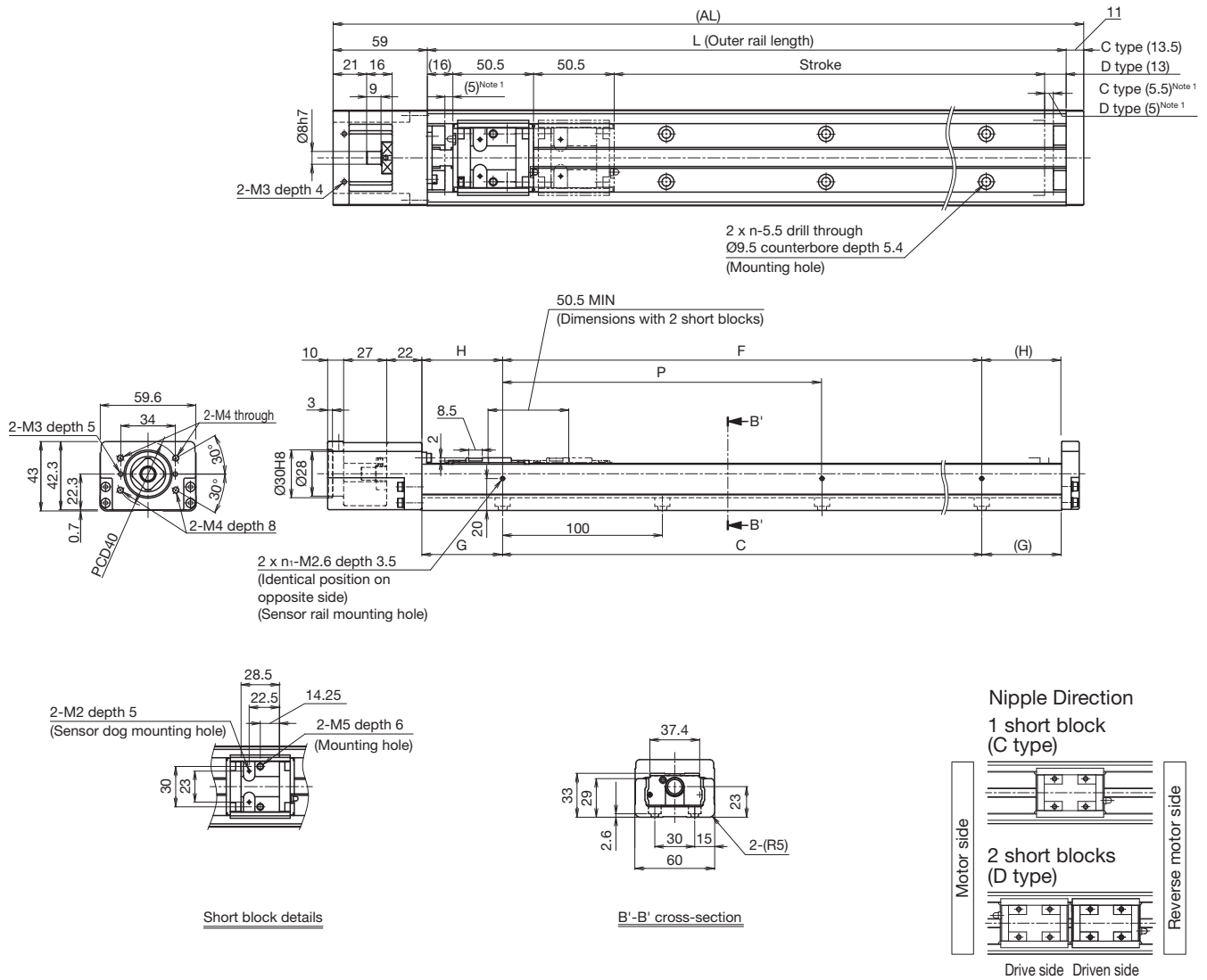

¹ Dimensions from the mechanical stopper to the stroke start position.

Stroke (mm) (Stroke between mechanical stoppers)	C type	70 (80.5)	120 (130.5)	220 (230.5)	320 (330.5)	420 (430.5)	520 (530.5)	620 (630.5)	
		D type ²	20 (30)	70 (80)	170 (180)	270 (280)	370 (380)	470 (480)	570 (580)
Maximum speed ³ (mm/s)	Ball screw lead: 6 mm	600						500	360
	Ball screw lead: 10 mm	1,000						830	600
Dimensions (mm)	AL	220	270	370	470	570	670	770	
	L	150	200	300	400	500	600	700	
	C	100	100	200	300	400	500	600	
	G	25	50	50	50	50	50	50	
	P	100	100	200	200	200	200	200	
	F	100	100	200	200	400	400	600	
	H	25	50	50	100	50	100	50	
No. of mounting holes	n	2	2	3	4	5	6	7	
	n ₁	2	2	2	2	3	3	4	
Mass ⁴ (kg)		1.7	2.1	2.8	3.5	4.3	5	5.7	

² The value with 2 short blocks (D type, without QZ) attached.
³ The maximum speed is restricted by the actuator's permissible speed.
⁴ The mass with 2 short blocks (D type) has 0.2 kg added.

With Cover
Motor Wrap

Dimensions

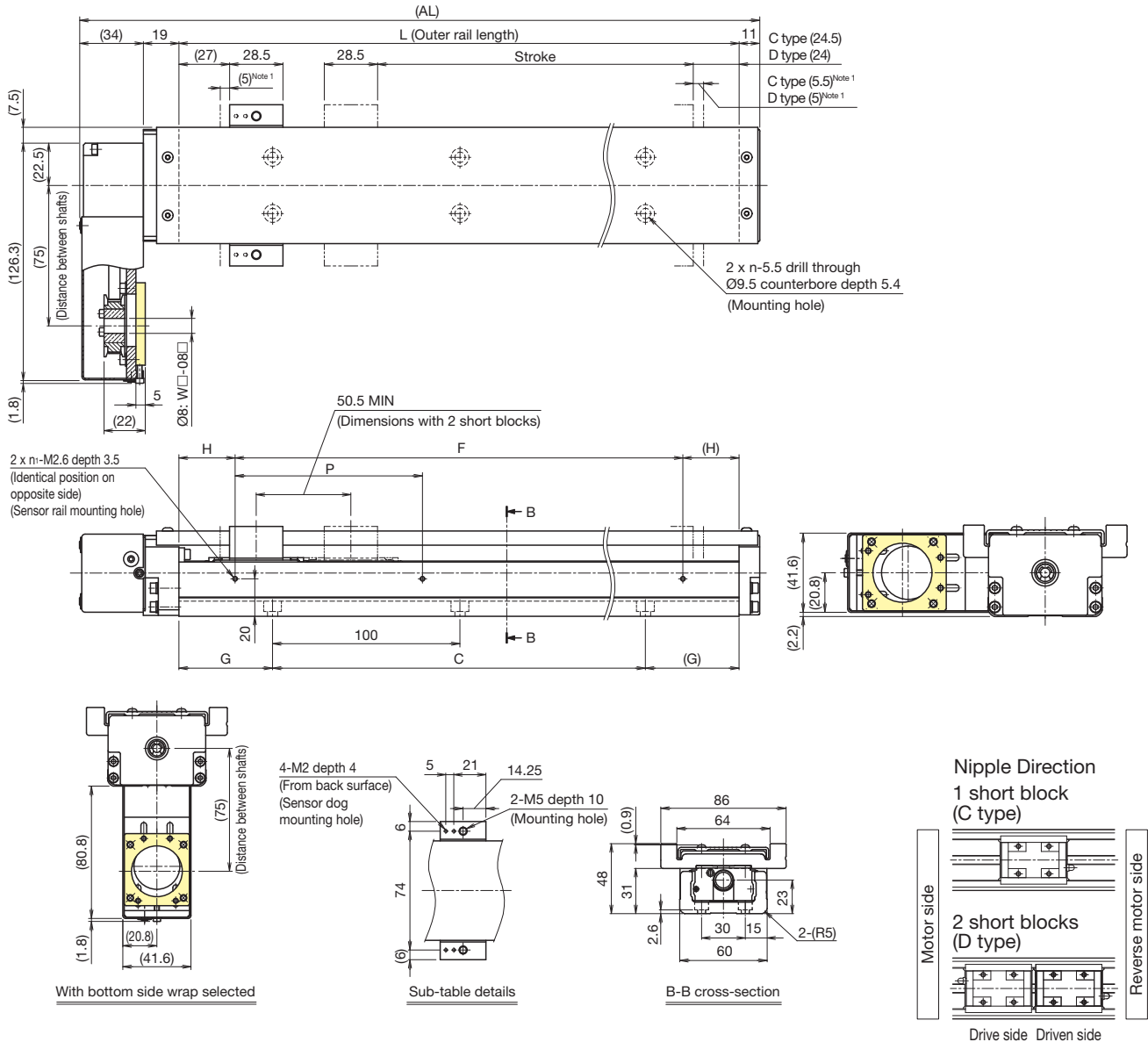

¹ Dimensions from the mechanical stopper to the stroke start position.

Stroke (mm) (Stroke between mechanical stoppers)	C type	70 (80.5)	120 (130.5)	220 (230.5)	320 (330.5)	420 (430.5)	520 (530.5)	620 (630.5)
	D type ²	20 (30)	70 (80)	170 (180)	270 (280)	370 (380)	470 (480)	570 (580)
Maximum speed ³ (mm/s)	Ball screw lead: 6 mm			600			500	360
	Ball screw lead: 10 mm			1,000			830	600
Dimensions (mm)	AL	214	264	364	464	564	664	764
	L	150	200	300	400	500	600	700
	C	100	100	200	300	400	500	600
	G	25	50	50	50	50	50	50
	P	100	100	200	200	200	200	200
	F	100	100	200	200	400	400	600
No. of mounting holes	n	2	2	3	4	5	6	7
	n ₁	2	2	2	2	3	3	4
Mass ⁴ (kg)		2.2	2.6	3.4	4.1	4.9	5.7	6.4

² The value with 2 short blocks (D type, without QZ) attached.

³ The maximum speed is restricted by the actuator's permissible speed.

⁴ The mass with 2 short blocks (D type) has 0.3 kg added.

Without Cover
Motor Wrap

Dimensions

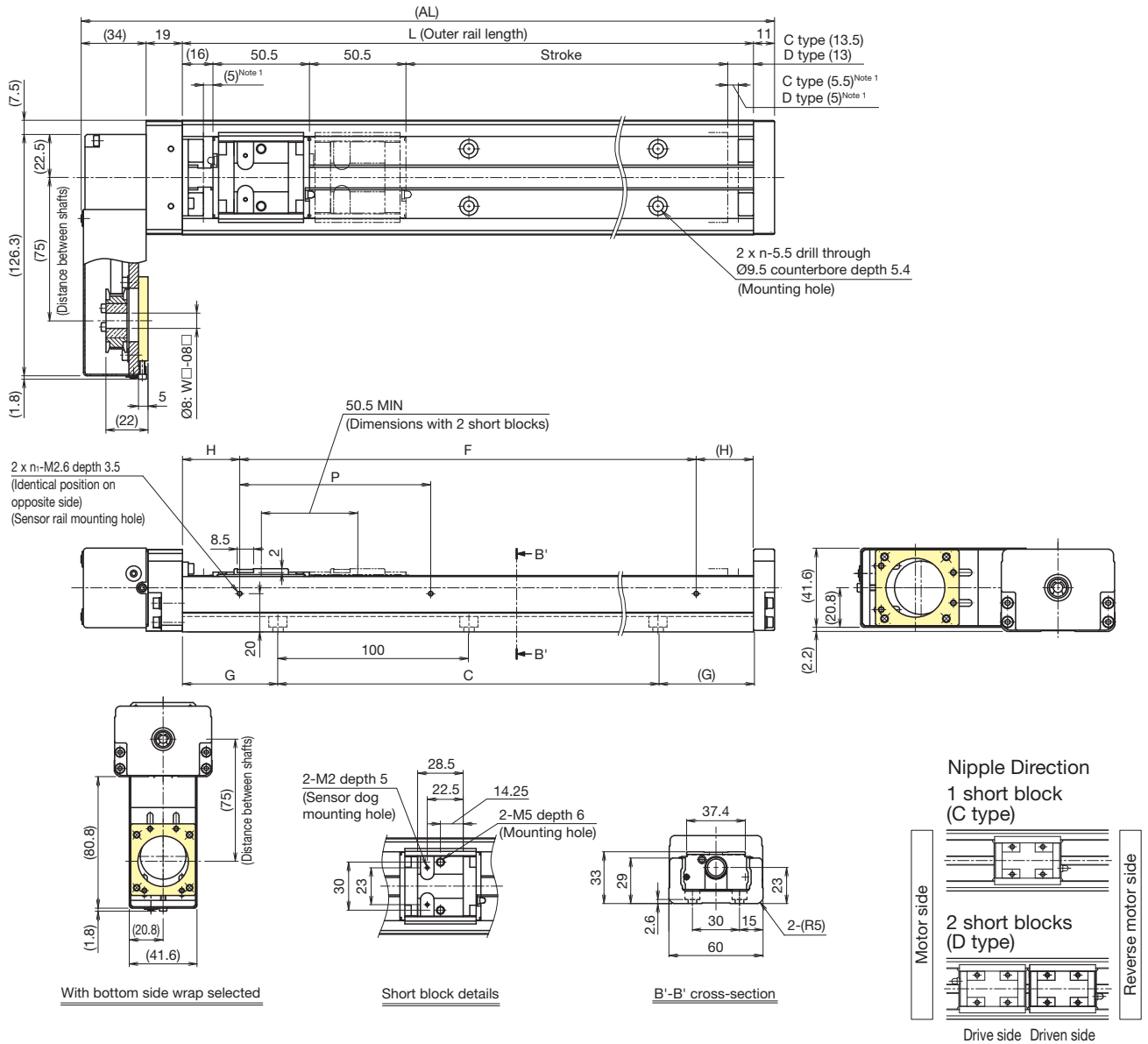

¹ Dimensions from the mechanical stopper to the stroke start position.

Stroke (mm) (Stroke between mechanical stoppers)	C type	70 (80.5)	120 (130.5)	220 (230.5)	320 (330.5)	420 (430.5)	520 (530.5)	620 (630.5)
	D type ²	20 (30)	70 (80)	170 (180)	270 (280)	370 (380)	470 (480)	570 (580)
Maximum speed ³ (mm/s)	Ball screw lead: 6 mm			600			500	360
	Ball screw lead: 10 mm			1,000			830	600
Dimensions (mm)	AL	214	264	364	464	564	664	764
	L	150	200	300	400	500	600	700
	C	100	100	200	300	400	500	600
	G	25	50	50	50	50	50	50
	P	100	100	200	200	200	200	200
	F	100	100	200	200	400	400	600
No. of mounting holes	n	2	2	3	4	5	6	7
	n ₁	2	2	2	2	3	3	4
Mass ⁴ (kg)		2	2.4	3.1	3.8	4.6	5.3	6

² The value with 2 short blocks (D type, without QZ) attached.
³ The maximum speed is restricted by the actuator's permissible speed.
⁴ The mass with 2 short blocks (D type) has 0.2 kg added.

Options

Sensors

Optional photo sensors and proximity sensors are available. Sensor-equipped models also feature a dedicated sensor rail and sensor dog.

Sensors, sensor rails, and sensor dogs can be mounted on both sides when the stroke is less than 70 mm.

Mounting example

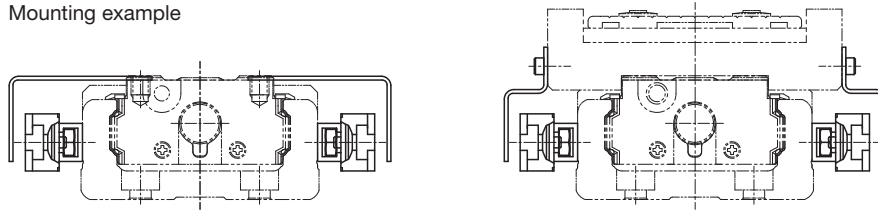

Symbol	Description	Model	Accessories
0	None	-	-
1	With sensor rail	-	Mounting screws, sensor rail (x1 or 2)
2	Photo sensor ¹ (x3)	EE-SX671 (OMRON Corporation)	Mounting screws, nuts, sensor dog (x1 or 2), sensor rail (x1 or 2), mounting plates (x3), connectors (EE-1001 x3)
6	Photo sensor ¹ (x3)	EE-SX674 (OMRON Corporation)	Mounting screws, nuts, sensor dog (x1 or 2), sensor rail (x1 or 2), mounting plates (x3), connectors (EE-1001 x3)
7	Proximity sensor N.O. contact ² (x3)	APM-D3A1-001 (Azbil Corporation)	Mounting screws, nuts, sensor dog (x1 or 2), sensor rail (x1 or 2)
B	Proximity sensor N.C. contact ³ (x3)	APM-D3B1-003 (Azbil Corporation)	Mounting screws, nuts, sensor dog (x1 or 2), sensor rail (x1 or 2)
E	Proximity sensor N.O. contact ² (x1) N.C. contact ³ (x2)	APM-D3A1-001 (Azbil Corporation) APM-D3B1-003 (Azbil Corporation)	Mounting screws, nuts, sensor dog (x1 or 2), sensor rail (x1 or 2)
H	Proximity sensor N.O. contact ² (x3)	GX-F12A (Panasonic Industry Co., Ltd.)	Mounting screws, nuts, sensor dog (x1 or 2), sensor rail (x1 or 2)
L	Proximity sensor N.C. contact ³ (x3)	GX-F12B (Panasonic Industry Co., Ltd.)	Mounting screws, nuts, sensor dog (x1 or 2), sensor rail (x1 or 2)
J	Proximity sensor N.O. contact ² (x1) N.C. contact ³ (x2)	GX-F12A (Panasonic Industry Co., Ltd.) GX-F12B (Panasonic Industry Co., Ltd.)	Mounting screws, nuts, sensor dog (x1 or 2), sensor rail (x1 or 2)
M	Proximity sensor N.O. contact ² (x1) (PNP output) N.C. contact ³ (x2) (PNP output)	GX-F12A-P (Panasonic Industry Co., Ltd.) GX-F12B-P (Panasonic Industry Co., Ltd.)	Mounting screws, nuts, sensor dog (x1 or 2), sensor rail (x1 or 2)

¹ The photo sensors can be switched between ON when lit and ON when unlit.

² N.O. contact: Normally open contact point

³ N.C. contact: Normally closed contact point

Notes: 1. If proximity sensors are close to one another, they may not function properly. If that happens, please prepare a type with a different frequency.

2. Mounting of sensors other than those in the table above is possible. Contact THK for details.

Sensor Rail Mounting Dimensions

Mounting only a sensor rail is also possible.

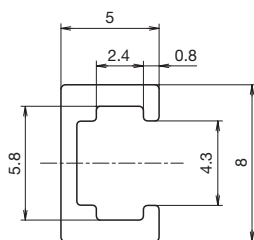

Sensor rail details

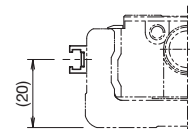
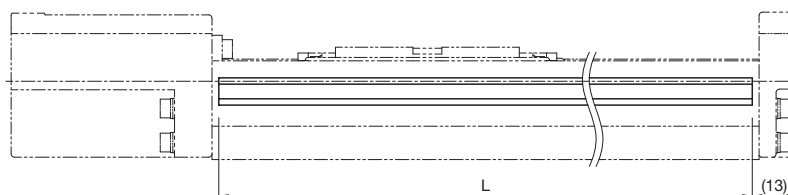

Stroke ⁴ (mm)	Outer rail length (mm)	L (mm)
45	150	146
95	200	196
195	300	296
295	400	396
395	500	496
495	600	596
595	700	696

⁴ Stroke with 1 block (A type).

Photo Sensor Mounting Dimensions

Connector: EE-1001 (OMRON Corporation) x3 included.
To be mounted by the customer.

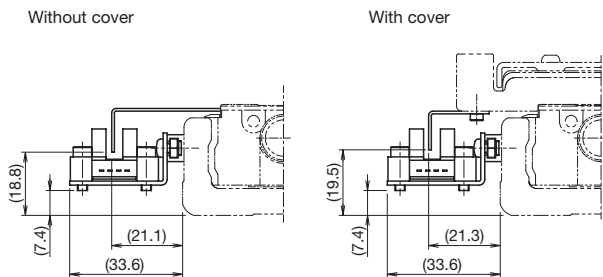

Symbol	Model	Manufacturer
2	EE-SX671	OMRON Corporation

Sensor dog width (without cover): 8.5 mm
Sensor dog width (with cover): 10 mm

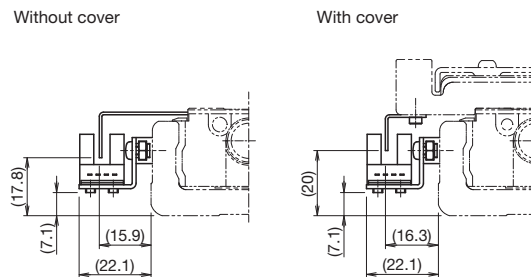

Symbol	Model	Manufacturer
6	EE-SX674	OMRON Corporation

Sensor dog width (without cover): 8.5 mm
Sensor dog width (with cover): 10 mm

Proximity Sensor Mounting Dimensions

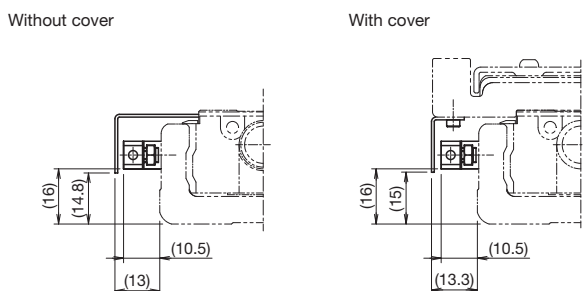

Symbol	Model	Manufacturer
7, B, E	APM-D3A1-001	Azbil Corporation
	APM-D3B1-003	

Sensor dog width (without cover): 8.5 mm
Sensor dog width (with cover): 10 mm

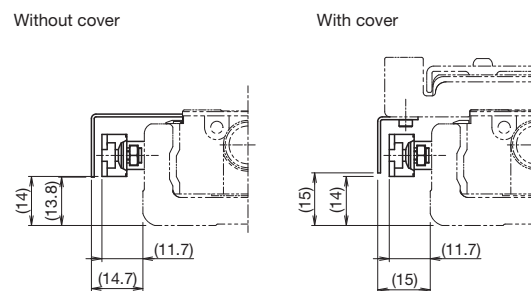

Symbol	Model	Manufacturer
H, L, J	GX-F12A	Panasonic Industry Co., Ltd.
	GX-F12B	
M	GX-F12A-P	
	GX-F12B-P	

Sensor dog width (without cover): 8.5 mm
Sensor dog width (with cover): 10 mm

Mounting Dimensions with Bellows

Photo sensor

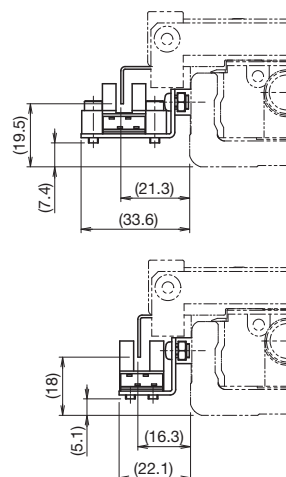

Symbol	Model	Manufacturer
2	EE-SX671	OMRON Corporation

Sensor dog width: 10 mm

Symbol	Model	Manufacturer
6	EE-SX674	OMRON Corporation

Sensor dog width: 10 mm

Proximity sensor

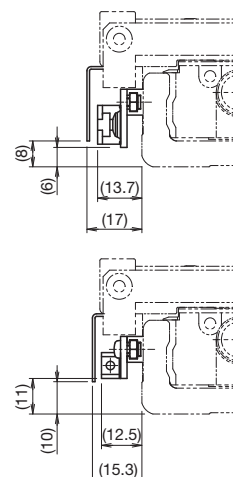

Symbol	Model	Manufacturer
7, B, E	APM-D3A1-001	Azbil Corporation
	APM-D3B1-003	

Sensor dog width: 10 mm

Symbol	Model	Manufacturer
H, L, J	GX-F12A	Panasonic Industry Co., Ltd.
	GX-F12B	
M	GX-F12A-P	
	GX-F12B-P	

Sensor dog width: 10 mm

Options

Intermediate Flange (Direct Coupling)

Several types of intermediate flanges for mounting motors are available.

When selecting "0" or "1" for Model Number Coding ⑦ With/without motor, specify an intermediate flange that matches the motor used.

Compatibility Table: Motors Used, Intermediate Flanges, and Couplings

Motor type	Manufacturer	Motor model		Motor rated output (W)	Flange size	Housing A/ Intermediate flange	Compatible coupling models		
							MIKI PULLEY CO., LTD.	Nabeya Bi-tech Kaisha (NBK)	
AC servo motor	YASKAWA Electric Corporation	Σ-V	SGMJV-A5	50	40×40	AQ	SFC-020DA2-8B-8B	XGT2-19C-8-8	
			SGMAV-A5						
			SGMJV-01	100					
			SGMAV-01						
		SGMJV-C2	150						
		Σ-7	SGM7J-A5	50	40×40	AQ	SFC-020DA2-8B-8B	XGT2-19C-8-8	
			SGM7A-A5						
			SGM7J-01	100					
			SGM7A-01						
		SGM7J-C2	150						
		Σ-X	SGMXJ-A5	50	40×40	AQ	SFC-020DA2-8B-8B	XGT2-19C-8-8	
			SGMXA-A5						
	SGMXJ-01		100						
	SGMXA-01								
	SGMXJ-C2	150							
	Mitsubishi Electric Corporation	MELSERVO	J4	HG-KR053	50	40×40	AQ	SFC-020DA2-8B-8B	XGT2-19C-8-8
				HG-MR053					
			HG-KR13	100					
			HG-MR13						
		J5	HK-KT053W	50	40×40	AQ	SFC-020DA2-8B-8B	XGT2-19C-8-8	
			HK-KT13W	100					
		JN	HF-KN053	50	40×40	AQ	SFC-020DA2-8B-8B	XGT2-19C-8-8	
			HF-KN13	100					
	TAMAGAWA SEIKI CO., LTD.	TBL-III	TS4602	50	40×40	AQ	SFC-020DA2-8B-8B	XGT2-19C-8-8	
			TS4603	100					
			TS4604	150					
		TBL-IV	TSM3102	50	40×40	AQ	SFC-020DA2-8B-8B	XGT2-19C-8-8	
			TSM3104	100					
	Panasonic Corporation	MINAS	A5	MSMD5A	50	38×38	AP	SFC-020DA2-8B-8B	XGT2-19C-8-8
				MSME5A					
			MSMD01	100					
			MSME01						
		A6	MSMF5A	50	38×38	AP	SFC-020DA2-8B-8B	XGT2-19C-8-8	
			MHMF5A	100	40×40	AQ	SFC-020DA2-8B-8B	XGT2-19C-8-8	
			MSMF01		38×38	AP	SFC-020DA2-8B-8B	XGT2-19C-8-8	
MHMF01			40×40	AQ	SFC-020DA2-8B-8B	XGT2-19C-8-8			
KEYENCE CORPORATION	SV	SV-M005	50	40×40	AQ	SFC-020DA2-8B-8B	XGT2-19C-8-8		
		SV-M010	100						
	SV2	SV2-M005	50	40×40	AQ	SFC-020DA2-8B-8B	XGT2-19C-8-8		
		SV2-M010	100						
SANYO DENKI CO., LTD.	SANMOTION R	R2□A04005	50	40×40	AQ	SFC-020DA2-8B-8B	XGT2-19C-8-8		
		R2EA04008	80						
		R2□A04010	100						
OMRON Corporation	OMNUC G5	R88M-K05030	50	40×40	AQ	SFC-020DA2-8B-8B	XGT2-19C-8-8		
		R88M-K10030	100						
FANUC CORPORATION	β is Series	R88M-1M10030	100	40×40	AQ	SFC-020DA2-8B-8B	XGT2-19C-8-8		
			βis0.2/5000	50	40×40	AQ	SFC-010DA2-8B-8B	XGT2-19C-8-8	
			βis0.3/5000	100					

Motor type	Manufacturer	Motor model		Flange size	Housing A/ Intermediate flange	Compatible coupling models		
						MIKI PULLEY CO., LTD.	Nabeya Bi-tech Kaisha (NBK)	
Stepper motor	ORIENTAL MOTOR CO., LTD.	α step	AZ4*, AR4* (excluding AZM48)	42×42	AR	SFC-010DA2-6B-8B-L29	XGT2-19C-6-8	
			AZM48	42×42	AR	SFC-010DA2-8B-8B-L29	XGT2-19C-8-8	
			AZ6*, AR6*	60×60	AU	SFC-020DA2-8B-10B	XGT2-25C-8-10	
		5-phase	CRK ¹	CRK54*	42×42	AR	SFC-010DA2-5B-8B-L29	XGT2-19C-5-8
				CRK56* (CRK569PM*)	60×60	AU	SFC-020DA2-8B-8B (SFC-020DA2-8B-10B)	XGT2-25C-8-8 (XGT2-25C-8-10)
			RK II	RKS54*	42×42	AR	SFC-010DA2-6B-8B-L29	XGT2-19C-6-8
				RKS56*	60×60	AU	SFC-020DA2-8B-10B	XGT2-25C-8-10
			PKP ¹	PKP54*	42×42	AR	SFC-010DA2-5B-8B-L29	XGT2-19C-5-8
				PKP56*	56.4×56.4	AT	SFC-020DA2-8B-8B	XGT2-25C-8-8
		2-phase	PKP/ CVD	PKP56* (PKP569FM*)	60×60	AU	SFC-020DA2-8B-8B (SFC-020DA2-8B-10B)	XGT2-25C-8-8 (XGT2-25C-8-10)
				PKP24*	42×42	AR	SFC-010DA2-5B-8B-L29	XGT2-19C-5-8
			KEYENCE CORPORATION	2-phase	PKP26*	56.4×56.4	AT	SFC-020DA2-8B-8B
	QS-M42				42×42	AR	SFC-010DA2-5B-8B-L29	XGT2-19C-5-8
	SANYO DENKI CO., LTD.	PB	QS-M60	60×60	AU	SFC-020DA2-8B-8B	XGT2-25C-8-8	
			PBDM423, PBA**423	42×42	AR	SFC-010DA2-6B-8B-L29	XGT2-19C-6-8	
		5-phase	PBDM60*, PBA**60*	60×60	AU	SFC-020DA2-8B-10B	XGT2-25C-8-10	
			FAF54*/FDF54*/FA511M42/FB511M42	42×42	AR	SFC-010DA2-6B-8B-L29	XGT2-19C-6-8	
			FAM56*/FDM56*/FA512M60/FB512M60	60×60	AU	SFC-020DA2-8B-10B	XGT2-25C-8-10	
		2-phase	DB14H52*	42×42	AR	SFC-010DA2-5B-8B-L29	XGT2-19C-5-8	
			DU15H52*		AR	SFC-010DA2-5B-8B-L29	XGT2-19C-5-8	
D*16H71*			56×56	AT	SFC-020DA2-6.35B-8B	XGT2-19C-6.35-8		
DB16H78*			60×60	AU	SFC-020DA2-8B-8B	XGT2-25C-8-8		

¹ Items in parentheses have different motor shaft diameters and require a coupling to be specified.

Notes: 1. The table shows only a portion of the model numbers for motors. For details regarding model numbers, please see the catalog for each respective motor manufacturer.

2. If the maximum torque for motors exceeds the permissible input torque (A/B → p. 35, C/D → p. 41), please consider a safety measure to limit the torque.

3. When installing a motor other than the motor model numbers listed above, contact THK.

Housing A

SKR33
A0

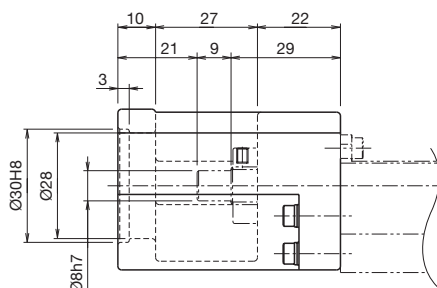
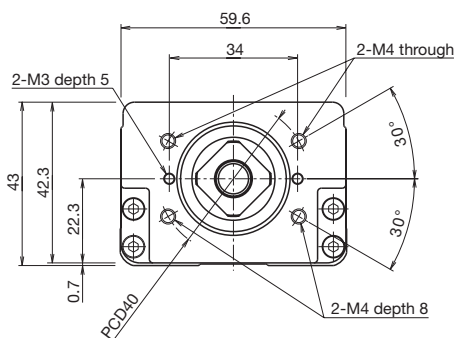

SKR**	Actuator model
●◇	●: Housing A ◇: Intermediate flange

Intermediate Flange

SKR33
AP

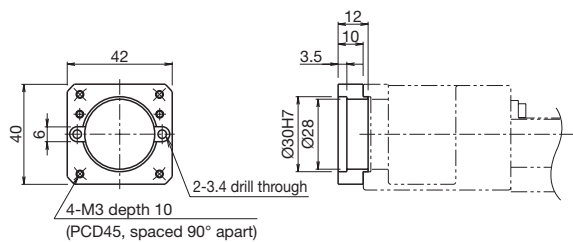

SKR33
AQ

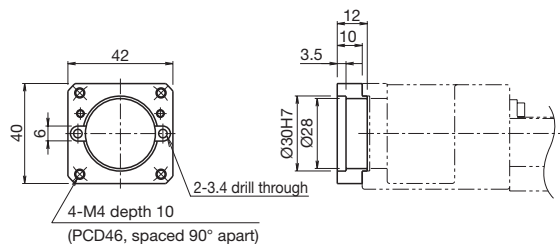

SKR33
AR

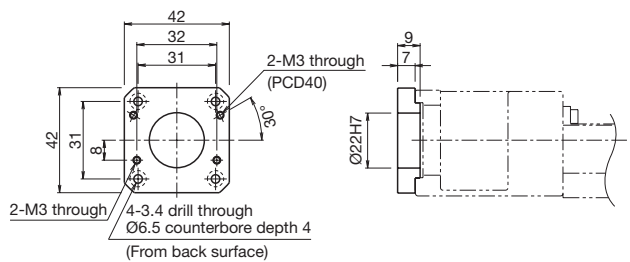

SKR33
AT

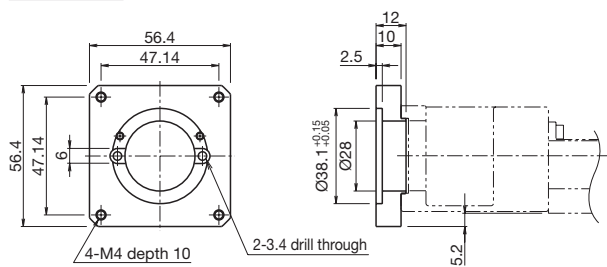

SKR33
AU

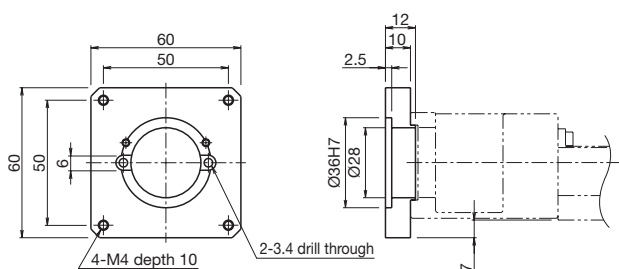

Options

Intermediate Flange (Motor Wrap)

Several types of intermediate flanges for mounting motors are available.

When selecting "R1," "R2," "R3," "R4," "R5," or "R6" for Model Number Coding ⑦ With/without motor, specify an intermediate flange that matches the motor used.

Symbol Coding

Motor wrap symbol ①	Intermediate flange ②	Motor shaft diameter (mm) ③	Motor shaft securing method ④
W	Q	08	D
W	Refer to the Compatibility Table: Motors Used and Motor Wrap Symbols below.	Specify a motor shaft diameter. (Refer to the Compatibility Table: Motors Used and Motor Wrap Symbols below.)	K: Key D: D-cut M: Friction tightening tool

Motor Shaft Securing Method

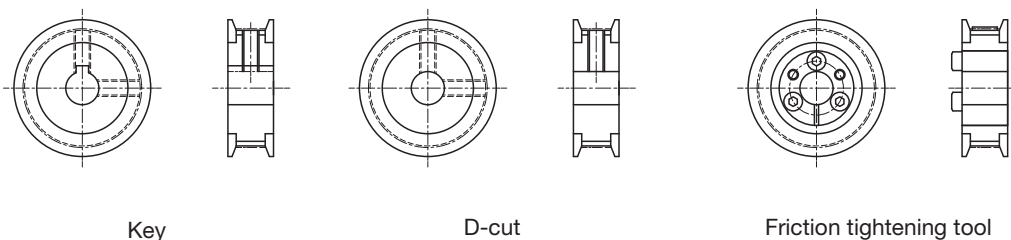

Compatibility Table: Motors Used and Motor Wrap Symbols

Motor type	Manufacturer	Motor model	Motor rated output (W)	Flange size	Housing A/Intermediate flange						
AC servo motor	YASKAWA Electric Corporation	Σ-V	SGMJV-A5	50	40×40	WQ-08K, WQ-08M					
			SGMAV-A5	100							
			SGMJV-01								
			SGMAV-01								
		SGMJV-C2	150	40×40							
		Σ-7	SGM7J-A5		50						
			SGM7A-A5		100						
			SGM7J-01								
			SGM7A-01								
		SGM7J-C2	150	40×40							
		Σ-X	SGMXJ-A5		50						
			SGMXA-A5		100						
	SGMXJ-01										
	SGMXA-01										
	SGMXJ-C2	150	40×40								
	SGMXA-C2	50		40×40							
					Mitsubishi Electric Corporation	MELSERVO	J4	HG-MR053	50	40×40	WQ-08D, WQ-08M
								HG-KR053			
			J5				HG-MR13	100			
	HG-KR13										
	JN	HK-KT053W	50	40×40	WQ-08D, WQ-08M						
		HK-KT13W	100								
	HF-KN053	50	40×40	WQ-08D, WQ-08M							
		HF-KN13			100						
	TAMAGAWA SEIKI CO., LTD.	TBL-III	TS4602	50	40×40	WQ-08D, WQ-08M					
			TS4603	100							
		TBL-IIV	TS4604	150							
			TSM3102	50			40×40	WQ-08D, WQ-08M			
	TSM3104	100									
	Panasonic Corporation	MINAS	A5	M5MD5A	50	38×38	WP-08D, WP-08K, WP-08M				
M5ME5A											
M5MD01											
M5ME01											
A6			M5MF5A	50	38×38			WP-08K, WP-08M			
			M5HMF5A		40×40			WQ-08K, WQ-08M			
			M5MFF01		100			38×38	WP-08K, WP-08M		
			M5HMF01					40×40	WQ-08K, WQ-08M		
KEYENCE CORPORATION		SV	SV-M005	50	40×40	WQ-08K, WQ-08M					
			SV-M010	100							
	SV2	SV2-M005	50								
		SV2-M010	100								
SANYO DENKI CO., LTD.	SANMOTION R	R2□A04005	50	40×40	WQ-08M						
		R2EA04008	80								
		R2□A04010	100								
		R2EA04010	100								
OMRON Corporation	OMNUC G5	R88M-K05030	50	40×40	WQ-08K, WQ-08M						
		R88M-K10030	100								
	1S	R88M-1M10030	100			40×40	WQ-08K, WQ-08M				

Notes: 1. The table shows only a portion of the model numbers for motors. For details regarding model numbers, please see the catalog for each respective motor manufacturer.
 2. If the maximum torque for motors exceeds the permissible input torque (A/B → p. 35, C/D → p. 41), please consider a safety measure to limit the torque.
 3. When installing a motor other than the motor model numbers listed above, contact THK.

Motor Wrap Housing A

SKR33
40

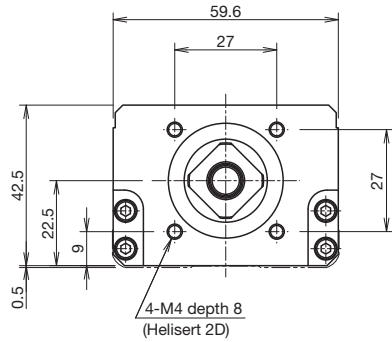

SKR**	Actuator model
●◇	●: Housing A ◇: Intermediate flange

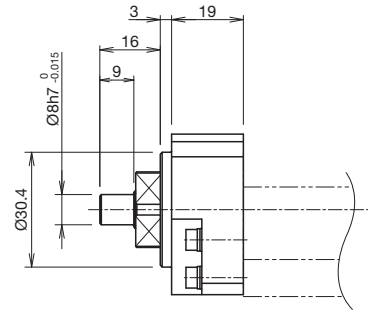

Note: The shaft end must be considered separately with motor wrap types.
Contact THK for details.

Motor Wrap Specification (Intermediate Flange)

SKR33
WQ

Thickness: 5 mm

SKR33
WP

Thickness: 5 mm

SKR**	Actuator model
W□	□: Intermediate flange

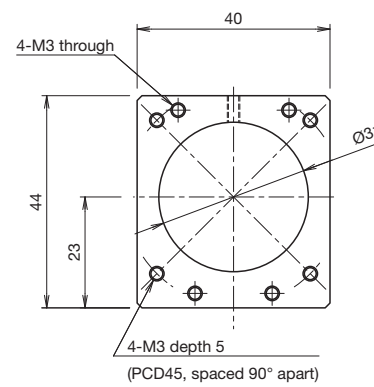
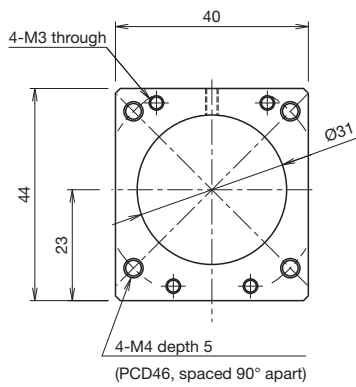

Options

QZ Lubricator

The QZ Lubricator for SKR feeds the right amount of lubricant to the outer rail and ball screw shaft raceways. This allows an oil film to be constantly formed between the balls and the raceway, and it significantly extends the lubrication maintenance interval.

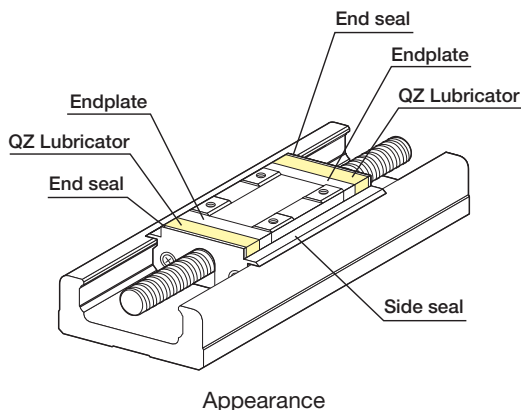

Features

- Since it compensates for oil loss, the lubrication maintenance interval can be significantly extended.
- It is an eco-friendly lubrication system that does not contaminate the surrounding area, as it feeds the right amount of lubricant to the ball raceway.

QZ Configuration

Symbol	Block type	Description
QZ	A/B/C/D	QZ all-block double-sided specification
QZA	A/C	QZ fixed side specification
QZB	A/C	QZ supported side specification
QZAD	B/D	QZ fixed side (drive side block) + QZ supported side (driven side block) specification

Note: QZ specification types do not have a grease nipple mounted. Contact THK if a grease nipple is required.

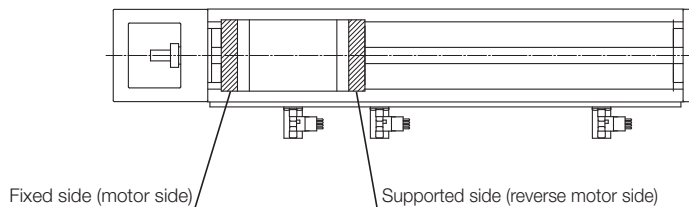

Block type \ QZ configuration	QZ	QZA	QZB	QZAD
A type (1 block)				-
B type (2 blocks)		-	-	
C type (1 short block)				-
D type (2 short blocks)		-	-	

Dimensions with QZ Lubricator

QZ (With Cover)

Block Type: A/B/C/D

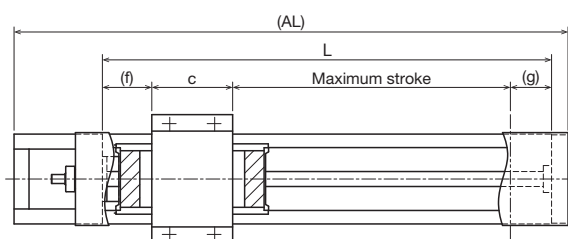

Block Type A/C

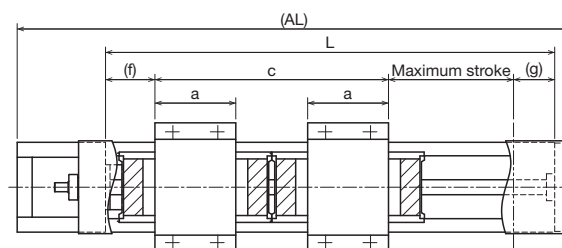

Block Type B/D

Unit: mm

Block type	Overall length AL	Outer rail length L	Stroke ¹	Maximum stroke ¹	a	c	f	g
A (3306) (3310)	270	200	70	79	-	54	35	32
	370	300	170	179				
	470	400	270	279				
	570	500	370	379				
	670	600	470	479				
770	700	570	579					
A (3320)	370	300	155	168.6	-	54	45.4	32
	470	400	255	268.6				
	570	500	355	368.6				
	670	600	455	468.6				
	770	700	555	568.6				
B (3306) (3310)	370	300	65	77	54	156	35	32
	470	400	165	177				
	570	500	265	277				
	670	600	365	377				
	770	700	465	477				
B (3320)	470	400	155	166.6	54	156	45.4	32
	570	500	255	266.6				
	670	600	355	366.6				
	770	700	455	466.6				
C	220	150	45	54.5	-	28.5	35	32
	270	200	95	104.5				
	370	300	195	204.5				
	470	400	295	304.5				
	570	500	395	404.5				
	670	600	495	504.5				
	770	700	595	604.5				
D	370	300	115	128	28.5	105	35	32
	470	400	215	228				
	570	500	315	328				
	670	600	415	428				
	770	700	515	528				

¹ The value for B/D block types is with 2 blocks attached.

Options

Dimensions with QZ Lubricator

QZ (Without Cover)
Block Type: A/B/C/D

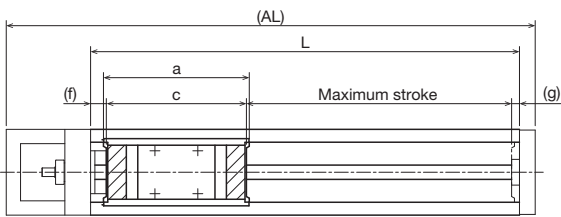

Block Type A/C

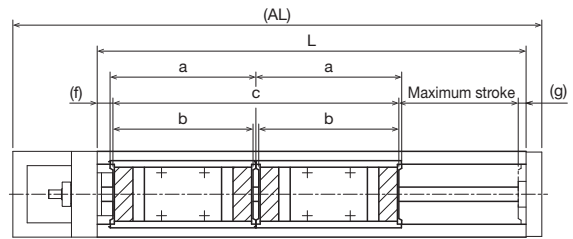

Block Type B/D

Unit: mm

Block type	Overall length AL	Outer rail length L	Stroke ¹	Maximum stroke ¹	a, b	c	f	g
A (3306) (3310)	270	200	70	79	102	102	11	8
	370	300	170	179				
	470	400	270	279				
	570	500	370	379				
	670	600	470	479				
A (3320)	370	300	155	168.6	112.4	112.4	11	8
	470	400	255	268.6				
	570	500	355	368.6				
	670	600	455	468.6				
	770	700	555	568.6				
B (3306) (3310)	370	300	65	77	102	204	11	8
	470	400	165	177				
	570	500	265	277				
	670	600	365	377				
	770	700	465	477				
B (3320)	470	400	155	166.6	112.4	214.4	11	8
	570	500	255	266.6				
	670	600	355	366.6				
	770	700	455	466.6				
C	220	150	45	54.5	76.5	76.5	11	8
	270	200	95	104.5				
	370	300	195	204.5				
	470	400	295	304.5				
	570	500	395	404.5				
	670	600	495	504.5				
	770	700	595	604.5				
D	370	300	115	128	76.5	153	11	8
	470	400	215	228				
	570	500	315	328				
	670	600	415	428				
	770	700	515	528				

¹ The value for B/D block types is with 2 blocks attached.

Dimensions with QZ Lubricator

QZA (With Cover)
Block Type: A/C

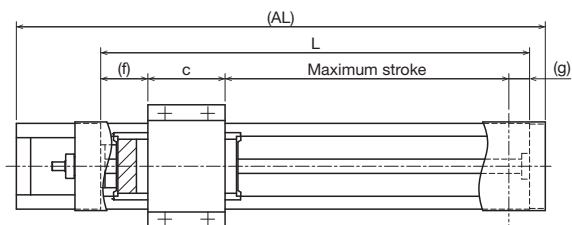

Block Type A/C

QZA (Without Cover)
Block Type: A/C

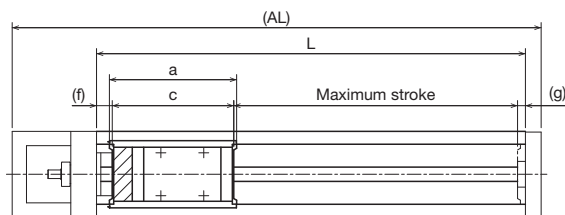

Block Type A/C

QZA (With Cover)

Unit: mm

Block type	Overall length AL	Outer rail length L	Stroke	Maximum stroke	c	f	g
A (3306) (3310)	270	200	80	92	54	35	19
	370	300	180	192			
	470	400	280	292			
	570	500	380	392			
	670	600	480	492			
	770	700	580	592			
A (3320)	370	300	170	181.6	54	45.4	19
	470	400	270	281.6			
	570	500	370	381.6			
	670	600	470	481.6			
	770	700	570	581.6			
C	220	150	55	67.5	28.5	35	19
	270	200	105	117.5			
	370	300	205	217.5			
	470	400	305	317.5			
	570	500	405	417.5			
	670	600	505	517.5			
	770	700	605	617.5			

Note 1: B/D block types cannot be selected for QZA.

QZA (Without Cover)

Unit: mm

Block type	Overall length AL	Outer rail length L	Stroke	Maximum stroke	a	c	f	g
A (3306) (3310)	270	200	80	92	89	89	11	8
	370	300	180	192				
	470	400	280	292				
	570	500	380	392				
	670	600	480	492				
	770	700	580	592				
A (3320)	370	300	170	181.6	99.4	99.4	11	8
	470	400	270	281.6				
	570	500	370	381.6				
	670	600	470	481.6				
	770	700	570	581.6				
C	220	150	55	67.5	63.5	63.5	11	8
	270	200	105	117.5				
	370	300	205	217.5				
	470	400	305	317.5				
	570	500	405	417.5				
	670	600	505	517.5				
	770	700	605	617.5				

Note 2: B/D block types cannot be selected for QZA.

Options

Dimensions with QZ Lubricator

QZB (With Cover)
Block Type: A/C

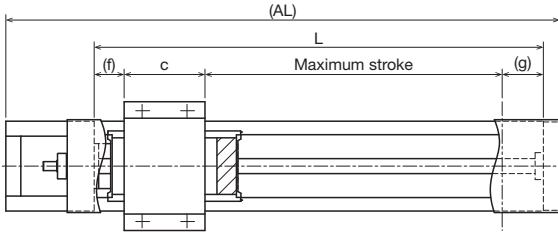

Block Type A/C

QZB (Without Cover)
Block Type: A/C

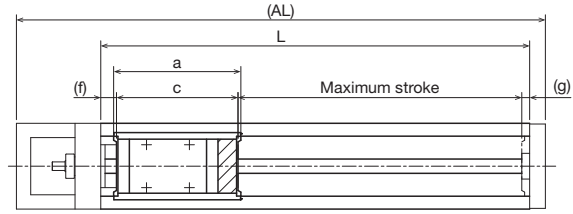

Block Type A/C

QZB (With Cover)

Unit: mm

Block type	Overall length AL	Outer rail length L	Stroke	Maximum stroke	c	f	g
A (3306) (3310)	270	200	80	92	54	22	32
	370	300	180	192			
	470	400	280	292			
	570	500	380	392			
	670	600	480	492			
	770	700	580	592			
A (3320)	270	200	80	92	54	22	32
	370	300	180	192			
	470	400	280	292			
	570	500	380	392			
	670	600	480	492			
	770	700	580	592			
C	220	150	55	67.5	28.5	22	32
	270	200	105	117.5			
	370	300	205	217.5			
	470	400	305	317.5			
	570	500	405	417.5			
	670	600	505	517.5			
	770	700	605	617.5			

Note 1: B/D block types cannot be selected for QZB.

QZB (Without Cover)

Unit: mm

Block type	Overall length AL	Outer rail length L	Stroke	Maximum stroke	a	c	f	g
A (3306) (3310)	270	200	80	92	89	89	11	8
	370	300	180	192				
	470	400	280	292				
	570	500	380	392				
	670	600	480	492				
	770	700	580	592				
A (3320)	270	200	80	92	89	89	11	8
	370	300	180	192				
	470	400	280	292				
	570	500	380	392				
	670	600	480	492				
	770	700	580	592				
C	220	150	55	67.5	63.5	63.5	11	8
	270	200	105	117.5				
	370	300	205	217.5				
	470	400	305	317.5				
	570	500	405	417.5				
	670	600	505	517.5				
	770	700	605	617.5				

Note 2: B/D block types cannot be selected for QZB.

Dimensions with QZ Lubricator

QZAD (With Cover)

Block Type: B/D

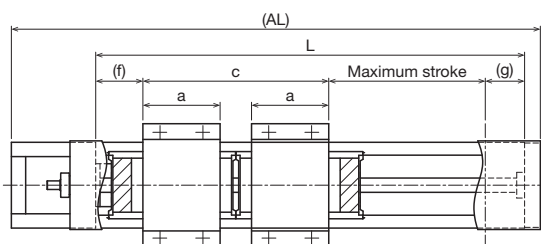

Block Type B/D

QZAD (Without Cover)

Block Type: B/D

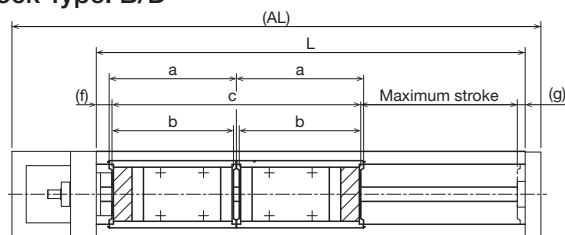

Block Type B/D

QZAD (With Cover)

Unit: mm

Block type	Overall length AL	Outer rail length L	Stroke ¹	Maximum stroke ¹	a	c	f	g
B (3306) (3310)	370	300	95	103	54	130	35	32
	470	400	195	203				
	570	500	295	303				
	670	600	395	403				
	770	700	495	503				
B (3320)	370	300	80	92.6	54	130	45.4	32
	470	400	180	192.6				
	570	500	280	292.6				
	670	600	380	392.6				
	770	700	480	492.6				
D	270	200	45	54	28.5	79	35	32
	370	300	145	154				
	470	400	245	254				
	570	500	345	354				
	670	600	445	454				
	770	700	545	554				

¹ The value for B/D block types is with 2 blocks attached.

Note 1: A/C block types cannot be selected for QZAD.

QZAD (Without Cover)

Unit: mm

Block type	Overall length AL	Outer rail length L	Stroke ²	Maximum stroke ²	a, b	c	f	g
B (3306) (3310)	370	300	95	103	89	178	11	8
	470	400	195	203				
	570	500	295	303				
	670	600	395	403				
	770	700	495	503				
B (3320)	370	300	80	92.6	99.4	188.4	11	8
	470	400	180	192.6				
	570	500	280	292.6				
	670	600	380	392.6				
	770	700	480	492.6				
D	270	200	45	54	63.5	127	11	8
	370	300	145	154				
	470	400	245	254				
	570	500	345	354				
	670	600	445	454				
	770	700	545	554				

² The value for B/D block types is with 2 blocks attached.

Note 2: A/C block types cannot be selected for QZAD.

SKR46 A/B

Direct motor coupling

Motor wrap

Width 86 mm

Height 46 mm

Max. stroke 790 mm

Model Number Coding

Model	Ball screw lead	Block type	QZ specification	Stroke	Accuracy grade	With/without motor	Cover	Sensors	Housing A/ Intermediate flange
①	②	③	④	⑤	⑥	⑦	⑧	⑨	⑩
SKR46	10	A	QZA	0175	P	0	1	2	AV
SKR46	10: 10 mm 20: 20 mm	A: x1 B: x2	No symbol: Without QZ QZ QZA QZB QZAD	0080: 80 mm to 0790: 790 mm When selecting 2: With bellows for ⑧ Cover, specify the stroke with bellows. → p. 109 to p. 110	No symbol: Normal grade H: High accuracy grade P: Precision grade	With direct coupling 0: Direct coupling (without motor) 1: Direct coupling (THK will purchase and mount the motor you specify.) With motor wrap R1: Non-standard side wrap (without motor) R2: Standard side wrap (without motor) R3: Bottom side wrap (without motor) R4: Non-standard side wrap (THK will purchase and mount the motor you specify.) R5: Standard side wrap (THK will purchase and mount the motor you specify.) R6: Bottom side wrap (THK will purchase and mount the motor you specify.) When selecting "0": A coupling is not provided. Indicate when placing an order if a coupling is required. When selecting "1," "R4," "R5," or "R6": The specified motor will be installed. Indicate the motor cable direction separately. Select ⑩ Intermediate flange to match the specified motor.	0: Without cover 1: With cover 2: With bellows	0 1 2 6 7 B E H L J M	With direct coupling A0 AU AV AY 60 With motor wrap WV-14M WY-11M WY-14M With direct coupling → p. 73 With motor wrap → p. 75
Sensor details → p. 71									

③ Block Type

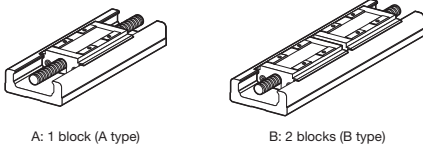

⑦ Motor Mounting Method

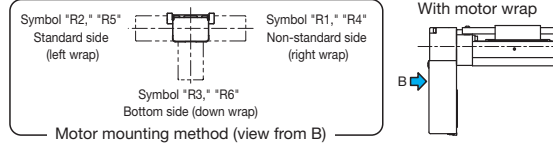

Selection Materials

Basic Specifications

LM Guide	Basic dynamic load rating C (N)		39,500
	Basic static load rating C ₀ (N)		45,900
	Radial clearance (mm)	Normal grade/High accuracy grade (H)	-0.006 to 0
		Precision grade (P)	-0.016 to -0.006
	Geometric moment of inertia	I _x ¹ (mm ⁴)	2.05×10 ⁶
I _y ² (mm ⁴)		1.45×10 ⁶	
Mass (kg/m)		12.6	
Ball screw	Ball screw lead (mm)		10 20
	Basic dynamic load rating Ca (N)	Normal grade/High accuracy grade (H)	4,350
		Precision grade (P)	4,240
	Basic static load rating C _{0a} (N)	Normal grade/High accuracy grade (H)	6,990
		Precision grade (P)	7,040
	Screw shaft diameter (mm)		Ø15
	Thread minor diameter (mm)		Ø12.4
	Ball center-to-center diameter (mm)		Ø15.75
Permissible rotational speed ³ (min ⁻¹)	Normal grade/High accuracy grade (H)	6,000	
	Precision grade (P)	6,000	
Bearing (Fixed side)	Axial direction	Basic dynamic load rating Ca (N)	6,700
		Static permissible load P _{0a} (N)	3,330
Permissible input torque (N·m)	Direct coupling	5.3	
	Motor wrap	4.5	
Static permissible moment ^{4,5} (N·m)		M _A : 579 (3,240), M _B : 579 (3,240), M _C : 1,390 (2,780)	
Running life ⁶ (km)		10,000	
Standard grease/Grease nipple used		THK AFB-LF Grease/A-M6F	

¹ I_x is the geometric moment of inertia about the X axis.

² I_y is the geometric moment of inertia about the Y axis.

³ The permissible rotational speed may decrease as the stroke becomes longer.

⁴ The value in parentheses is with 2 blocks (B type) attached.

⁵ See p. 116 for the values if "1" or "2" is selected for item ⑧ in the Model Number Coding.

⁶ Calculated under the following conditions.

Stroke: 490 mm (A type), 380 mm (B type) / Speed: 500 mm/s (for 10 mm lead), 1,000 mm/s (for 20 mm lead) / Load mass: Maximum load capacity (p. 9) / Acceleration/deceleration: As when set to maximum load capacity (p. 9) / Center of gravity: Center of the table's upper surface.

Notes: 1. Customized products can also be made to handle special environments or large axial loads (25% or more of the basic dynamic load rating Ca). Consult with THK.

2. LM Guide load rating is the load rating per block.

Accuracy

Accuracy grade	Item	Stroke ⁷						
		190	290	390	490	590	690	790
Normal grade (no symbol)	Positioning repeatability (mm)	±0.01						
	Positioning accuracy (mm)	Not specified						
	Running parallelism (vertical direction) (mm)	Not specified						
	Backlash (mm)	0.02						
	Starting torque (N·cm)	10						

Accuracy grade	Item	Stroke ⁷						
		190	290	390	490	590	690	790
High accuracy grade (H)	Positioning repeatability (mm)	±0.005						
	Positioning accuracy (mm)	0.1			0.12		0.15	
	Running parallelism (vertical direction) (mm)	0.035			0.04		0.05	
	Backlash (mm)	0.02						
	Starting torque (N·cm)	10						

Accuracy grade	Item	Stroke ⁷						
		190	290	390	490	590	690	790
Precision grade (P)	Positioning repeatability (mm)	±0.003						
	Positioning accuracy (mm)	0.025			0.03			
	Running parallelism (vertical direction) (mm)	0.015			0.02			
	Backlash (mm)	0.003						
	Starting torque (N·cm)	15		17				

⁷ Stroke with 1 block (A type, without QZ).

Notes: 3. Precision evaluation in accordance with THK standards.

4. Measured using a motor for inspection. With motor wrap specifications, measurements are not made in the completed motor wrap state.

5. The starting torque represents the value when containing THK AFB-LF Grease.

6. The starting torque may exceed standards if using vacuum grease, clean room grease, or other high-viscosity greases, so care should be taken when selecting a motor.

7. Contact THK for accuracy higher than the standard stroke.

Geometric Moment of Inertia

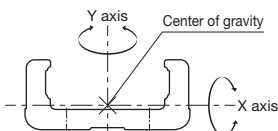

Static Permissible Moment

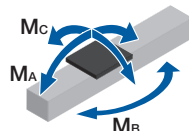

Motor Selection Information

Stroke ¹ (mm)	Outer rail length (mm)	LM Guide				Ball screw		Motor mounting part	
		Moving part mass (kg)			Sliding resistance value ² (N)	Lead (mm)	Shaft length (mm)	Direct coupling	Motor wrap
		Block mass	Sub-table mass	Total mass				Shaft end diameter (mm)	Timing pulley (sum of two) Inertial moment x 10 ⁻⁴ (kg·m ²)
190 to 790	340 to 940	A type: 1 B type: 2	A type: 0.4 B type: 0.8	A type: 1.4 B type: 2.8	8.1	10, 20	405 to 1,005	Ø10h7	0.86

¹ Stroke with 1 block (A type, without QZ).

² Value with 1 block (A type, without QZ). This value is the sum of the rolling resistance value and seal resistance value.

Note: Refer to p. 73 for applicable couplings.

Permissible Overhang Length³

Horizontal

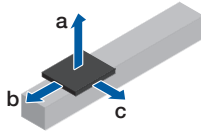

Wall-Mounted

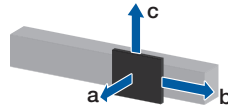

Vertical

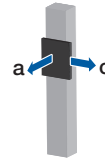

Estimated motor capacity 200 W	Ball screw lead (mm)	Load mass (kg)	a (mm)	b (mm)	c (mm)	
Direct coupling	A type	10	19	190	60	60
			38.5	70	30	30
		77	20	10	10	
		20	6	680	210	210
			12	320	100	100
		B type	10	24	140	50
	26.5			740	230	90
	53		350	110	40	
	20		106	150	50	20
			4.5	860	860	570
	9.5		860	650	270	
	19.5	860	310	130		
Motor wrap	A type	10	17.5	210	70	70
			35	80	30	30
		70	20	10	10	
		20	3.5	860	370	370
			7.5	530	170	170
		15	250	80	80	
	B type	10	20.5	860	300	120
			41.5	460	140	60
		20	83	210	70	30
			3	860	860	860
		6.5	860	860	400	
		13.5	860	460	190	

Estimated motor capacity 200 W	Ball screw lead (mm)	Load mass (kg)	a (mm)	b (mm)	c (mm)	
Direct coupling	A type	10	19	20	130	450
			38.5	0	60	220
		77	0	30	110	
		20	6	170	430	860
			12	60	210	720
		B type	10	24	10	100
	26.5			50	270	
	53		0	130	450	
	20		106	0	60	220
			4.5	530	860	860
	9.5		230	750	860	
	19.5	90	360	860		
Motor wrap	A type	10	17.5	30	140	490
			35	0	70	240
		70	0	30	120	
		20	3.5	320	740	860
			7.5	130	340	860
		15	40	170	570	
	B type	10	20.5	80	350	860
			41.5	20	170	570
		20	83	0	80	280
			3	820	860	860
		6.5	350	860	860	
		13.5	150	530	860	

Estimated motor capacity 200 W	Ball screw lead (mm)	Load mass (kg)	a (mm)	c (mm)	
Direct coupling	A type	10	4.5	180	440
			9	70	220
		18	10	110	
		20	2	460	860
			4	210	500
		B type	10	8	80
	5.5			830	860
	11.5		370	480	
	20		23.5	160	230
			2	860	860
	4		860	860	
	8.5	520	650		
Motor wrap	A type	10	4	210	500
			8	80	250
		16	20	120	
		20	1.5	620	860
			3.5	240	570
		7	100	280	
	B type	10	3.5	860	860
			7	640	790
		20	14.5	290	380
			1.5	860	860
		3	860	860	
		6.5	690	850	

Estimated motor capacity 400 W	Ball screw lead (mm)	Load mass (kg)	a (mm)	b (mm)	c (mm)	
Direct coupling	A type	10	24	140	50	50
			48	50	20	20
		96	0	10	10	
		20	13.5	280	90	90
			27.5	120	40	40
		55.5	40	20	20	
	B type	10	34	570	180	70
			68	260	90	30
		20	136	110	40	10
			12	860	510	210
		24	820	250	100	
		48	390	120	50	
Motor wrap	A type	10	24	140	50	50
			48	50	20	20
		96	0	10	10	
		20	10.5	370	120	120
			21.5	160	60	60
		43	60	30	30	
	B type	10	34	570	180	70
			68	260	90	30
		20	136	110	40	10
			10.5	860	590	240
		21	860	290	120	
		42	450	140	60	

Estimated motor capacity 400 W	Ball screw lead (mm)	Load mass (kg)	a (mm)	b (mm)	c (mm)	
Direct coupling	A type	10	19	20	130	450
			38.5	0	60	220
		77	0	30	110	
		20	12.5	170	430	860
			25	60	210	720
		50	10	100	360	
	B type	10	27	50	270	860
			54	0	130	450
		20	108.5	0	60	220
			12	530	860	860
		24	230	750	860	
		48	90	360	1,230	
Motor wrap	A type	10	19	30	140	490
			38.5	0	70	240
		77	0	30	120	
		20	10.5	320	740	860
			21.5	130	340	860
		43	40	170	570	
	B type	10	27	80	350	860
			54	20	170	570
		20	108.5	0	80	280
			10.5	820	860	860
		21	350	860	860	
		42	150	530	860	

Estimated motor capacity 400 W	Ball screw lead (mm)	Load mass (kg)	a (mm)	c (mm)	
Direct coupling	A type	10	5.5	140	360
			11.5	50	170
		23	0	80	
		20	4.5	180	440
			9	70	220
		18	10	110	
	B type	10	8	560	690
			16	260	340
		20	32.5	110	170
			5	860	860
		10	440	550	
		20.5	190	270	
Motor wrap	A type	10	4	210	500
			8	80	250
		16	20	120	
		20	4	210	500
			8	80	250
		16	20	120	
	B type	10	3.5	860	860
			7	640	790
		20	14.5	290	380
			3.5	860	860
		7	640	790	
		14.5	290	380	

³ This is the value with the service life of the LM Guide limited to 10,000 km. The calculation conditions are as follows.

Stroke: 490 mm (A type), 380 mm (B type) / Acceleration/deceleration: 0.3 G / Speed: 500 mm/s (for 10 mm lead), 1,000 mm/s (for 20 mm lead) / Overhang direction: Loaded in only a single direction. Dimensions a, b, and c are from the center of the table's upper surface.

With Cover
Direct Motor Coupling

Dimensions

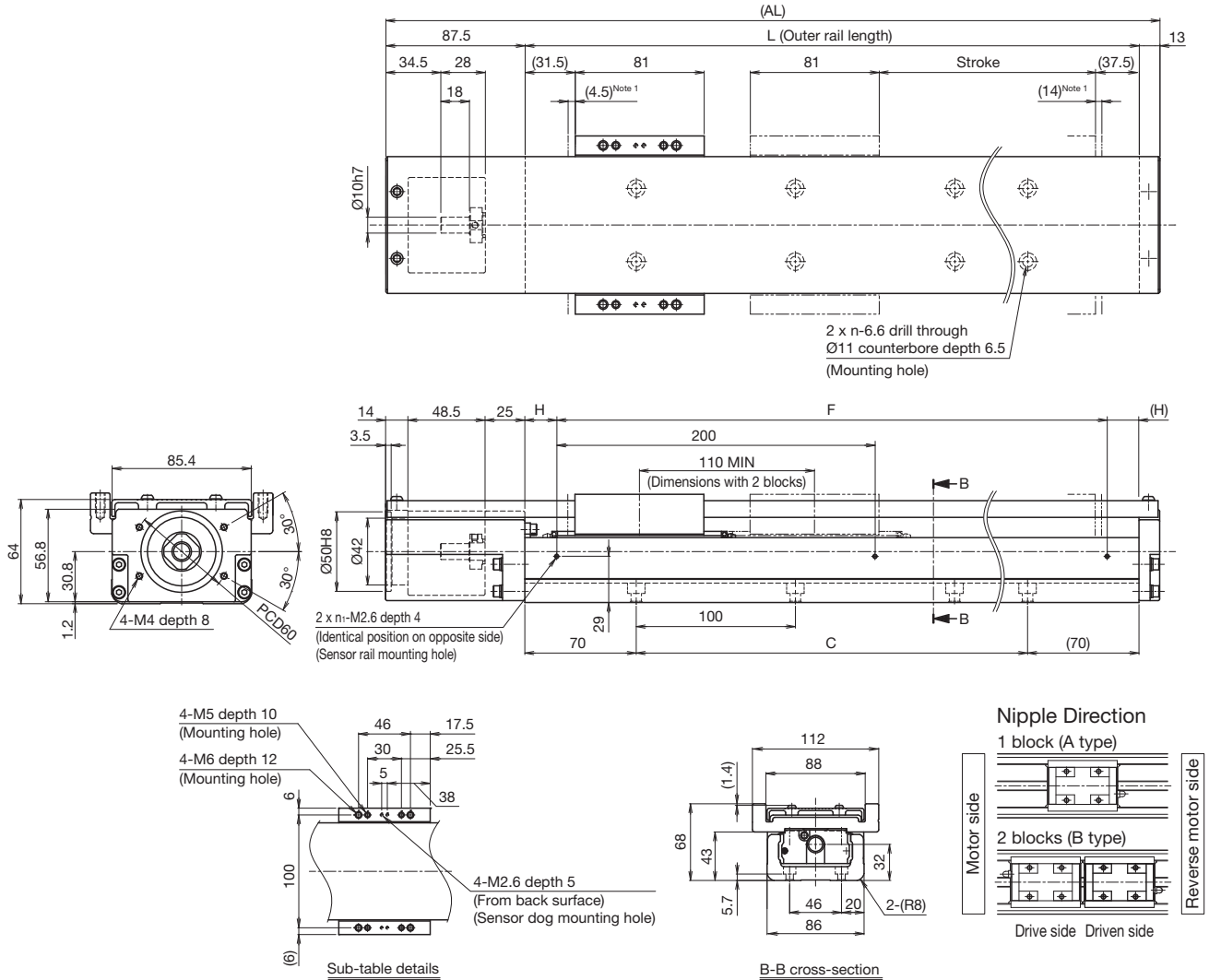

¹ Dimensions from the mechanical stopper to the stroke start position.

Stroke (mm) (Stroke between mechanical stoppers)	A type	190 (208.5)	290 (308.5)	390 (408.5)	490 (508.5)	590 (608.5)	690 (708.5)	790 (808.5)
	B type ²	80 (98.5)	180 (198.5)	280 (298.5)	380 (398.5)	480 (498.5)	580 (598.5)	680 (698.5)
Maximum speed ³ (mm/s)	Ball screw lead: 10 mm	1,000				730	550	430
	Ball screw lead: 20 mm	2,000		1,980		1,430	1,080	840
Dimensions (mm)	AL	440.5	540.5	640.5	740.5	840.5	940.5	1,040.5
	L	340	440	540	640	740	840	940
	C	200	300	400	500	600	700	800
	F	200	400	400	600	600	800	800
	H	70	20	70	20	70	20	70
No. of mounting holes	n	3	4	5	6	7	8	9
	n ₁	2	3	3	4	4	5	5
Mass ⁴ (kg)		7.7	9.2	10.7	12.2	13.7	15.2	16.7

² The value with 2 blocks (B type, without QZ) attached.

³ The maximum speed is restricted by the actuator's permissible speed.

⁴ The mass with 2 blocks (B type) has 1.4 kg added.

Without Cover
Direct Motor Coupling

Dimensions

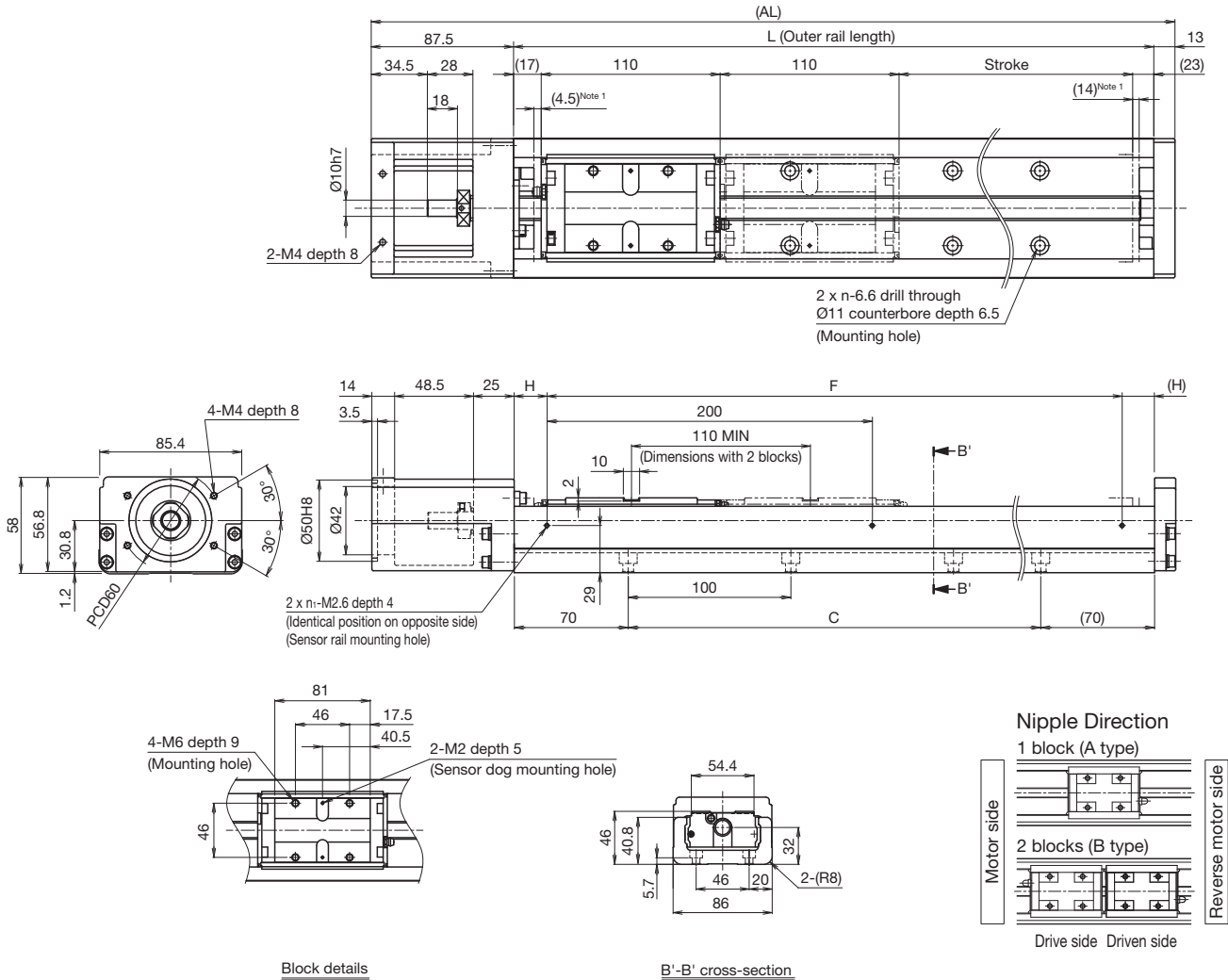

¹ Dimensions from the mechanical stopper to the stroke start position.

Stroke (mm) (Stroke between mechanical stoppers)	A type	190 (208.5)	290 (308.5)	390 (408.5)	490 (508.5)	590 (608.5)	690 (708.5)	790 (808.5)
	B type ²	80 (98.5)	180 (198.5)	280 (298.5)	380 (398.5)	480 (498.5)	580 (598.5)	680 (698.5)
Maximum speed ³ (mm/s)	Ball screw lead: 10 mm	1,000				730	550	430
	Ball screw lead: 20 mm	2,000				1,980	1,430	840
Dimensions (mm)	AL	440.5	540.5	640.5	740.5	840.5	940.5	1,040.5
	L	340	440	540	640	740	840	940
	C	200	300	400	500	600	700	800
	F	200	400	400	600	600	800	800
	H	70	20	70	20	70	20	70
No. of mounting holes	n	3	4	5	6	7	8	9
	n ₁	2	3	3	4	4	5	5
Mass ⁴ (kg)		6.7	8.1	9.5	10.9	12.3	13.8	15.2

² The value with 2 blocks (B type, without QZ) attached.
³ The maximum speed is restricted by the actuator's permissible speed.
⁴ The mass with 2 blocks (B type) has 1 kg added.

With Cover
Motor Wrap

Dimensions

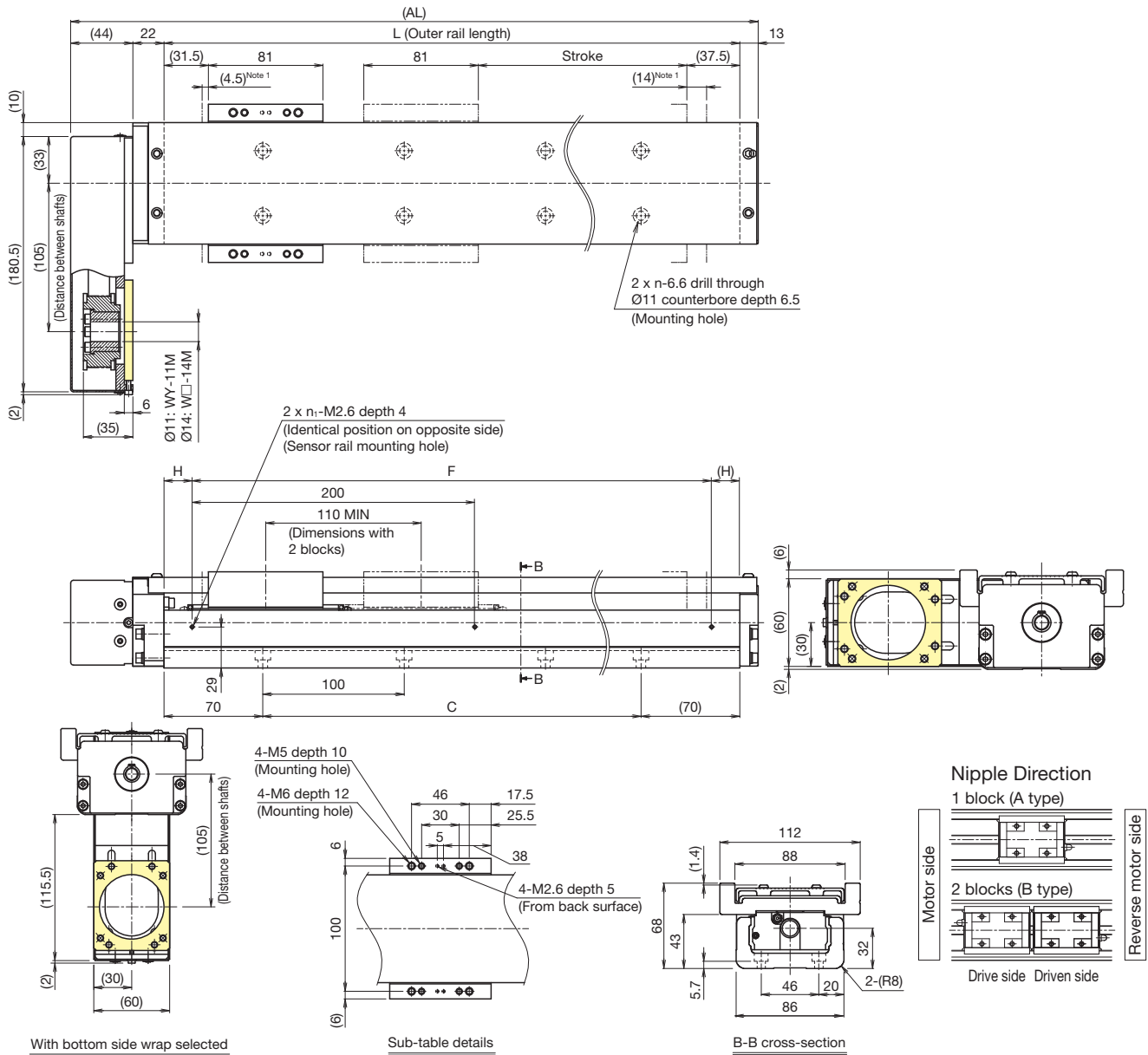

With bottom side wrap selected

Sub-table details

B-B cross-section

¹ Dimensions from the mechanical stopper to the stroke start position.

Stroke (mm) (Stroke between mechanical stoppers)	A type	190 (208.5)	290 (308.5)	390 (408.5)	490 (508.5)	590 (608.5)	690 (708.5)	790 (808.5)
	B type ²	80 (98.5)	180 (198.5)	280 (298.5)	380 (398.5)	480 (498.5)	580 (598.5)	680 (698.5)
Maximum speed ³ (mm/s)	Ball screw lead: 10 mm	1,000				730	550	430
	Ball screw lead: 20 mm		2,000		1,980	1,430	1,080	840
Dimensions (mm)	AL	419	519	619	719	819	919	1,019
	L	340	440	540	640	740	840	940
	C	200	300	400	500	600	700	800
	F	200	400	400	600	600	800	800
	H	70	20	70	20	70	20	70
No. of mounting holes	n	3	4	5	6	7	8	9
	n ₁	2	3	3	4	4	5	5
Mass ⁴ (kg)		8.6	10.1	11.6	13.1	14.6	16.1	17.6

² The value with 2 blocks (B type, without QZ) attached.

³ The maximum speed is restricted by the actuator's permissible speed.

⁴ The mass with 2 blocks (B type) has 1.4 kg added.

Without Cover
Motor Wrap

Dimensions

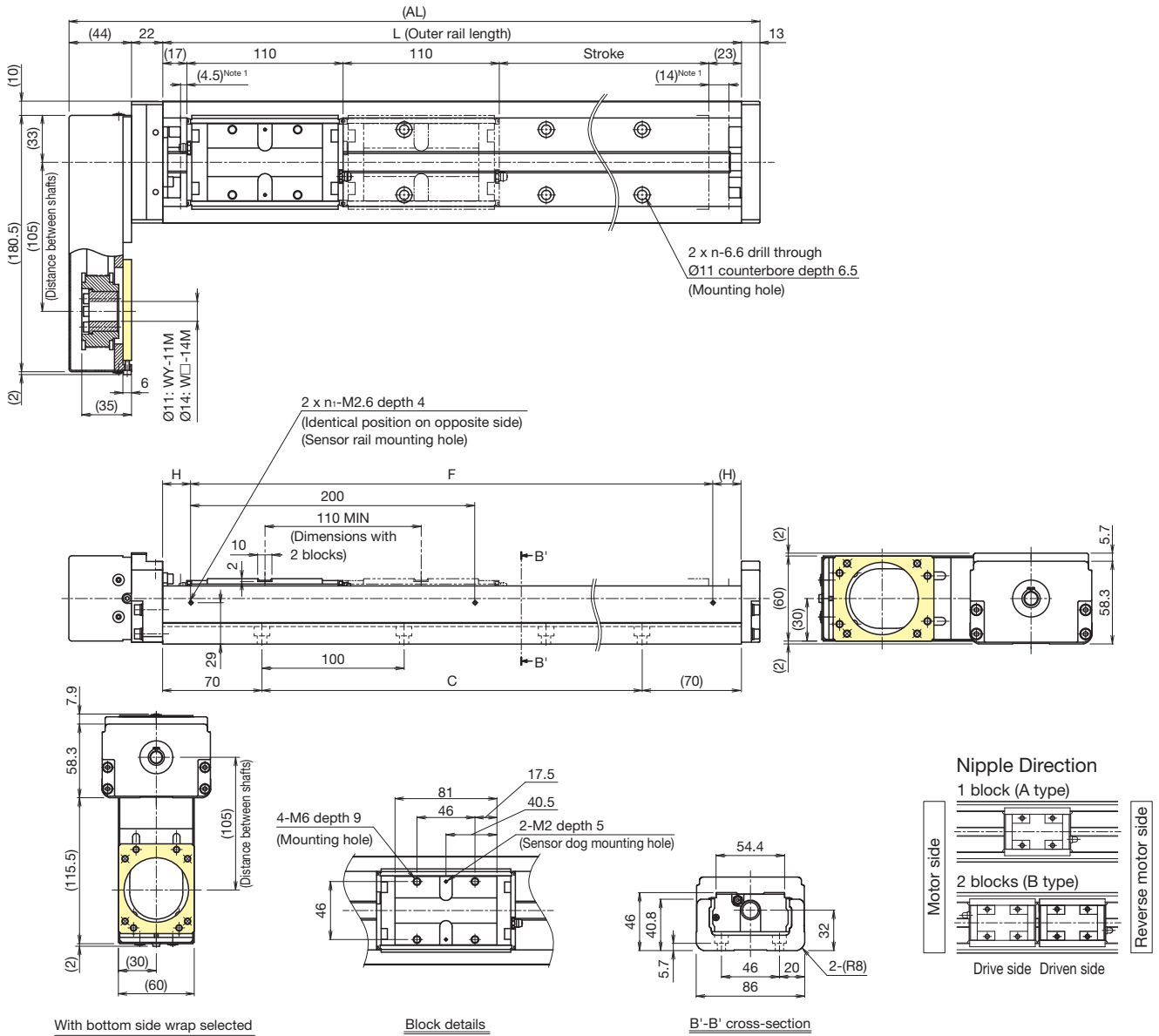

¹ Dimensions from the mechanical stopper to the stroke start position.

Stroke (mm) (Stroke between mechanical stoppers)	A type	190 (208.5)	290 (308.5)	390 (408.5)	490 (508.5)	590 (608.5)	690 (708.5)	790 (808.5)
	B type ²	80 (98.5)	180 (198.5)	280 (298.5)	380 (398.5)	480 (498.5)	580 (598.5)	680 (698.5)
Maximum speed ³ (mm/s)	Ball screw lead: 10 mm	1,000				730	550	430
	Ball screw lead: 20 mm		2,000		1,980	1,430	1,080	840
Dimensions (mm)	AL	419	519	619	719	819	919	1,019
	L	340	440	540	640	740	840	940
	C	200	300	400	500	600	700	800
	F	200	400	400	600	600	800	800
	H	70	20	70	20	70	20	70
No. of mounting holes	n	3	4	5	6	7	8	9
	n ₁	2	3	3	4	4	5	5
Mass ⁴ (kg)		7.7	9.1	10.5	11.9	13.3	14.7	16.1

² The value with 2 blocks (B type, without QZ) attached.

³ The maximum speed is restricted by the actuator's permissible speed.

⁴ The mass with 2 blocks (B type) has 1 kg added.

SKR46 C/D

Direct motor coupling	Motor wrap	Width 86 mm	Height 46 mm	Max. stroke 820 mm
-----------------------	------------	-------------	--------------	--------------------

Model Number Coding

Model	Ball screw lead	Block type	QZ specification	Stroke	Accuracy grade	With/without motor	Cover	Sensors	Housing A/ Intermediate flange
①	②	③	④	⑤	⑥	⑦	⑧	⑨	⑩
SKR46	10	C	QZA	0205	P	0	1	2	AV
SKR46	10: 10 mm 20: 20 mm	C: x1 D: x2	No symbol: Without QZ QZ QZA QZB QZAD	0145: 145 mm to 0820: 820 mm	No symbol: Normal grade H: High accuracy grade P: Precision grade	With direct coupling 0: Direct coupling (without motor) 1: Direct coupling (THK will purchase and mount the motor you specify.) With motor wrap R1: Non-standard side wrap (without motor) R2: Standard side wrap (without motor) R3: Bottom side wrap (without motor) R4: Non-standard side wrap (THK will purchase and mount the motor you specify.) R5: Standard side wrap (THK will purchase and mount the motor you specify.) R6: Bottom side wrap (THK will purchase and mount the motor you specify.)	0: Without cover 1: With cover 2: With bellows	0 1 2 6 7 B E H L J M	With direct coupling A0 AU AV AY 60 With motor wrap WV - 14M WY - 11M WY - 14M With direct coupling → p. 73 With motor wrap → p. 75
Check the stroke for type with QZ when selecting anything other than "No symbol." → p. 77 to p. 82				When selecting ⑤ Cover, specify the stroke with bellows. → p. 111 to p. 112		When selecting "0": A coupling is not provided. Indicate when placing an order if a coupling is required. When selecting "1," "R4," "R5," or "R6": The specified motor will be installed. Indicate the motor cable direction separately. Select ⑩ Intermediate flange to match the specified motor.			

③ Block Type

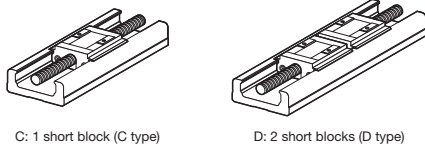

⑦ Motor Mounting Method

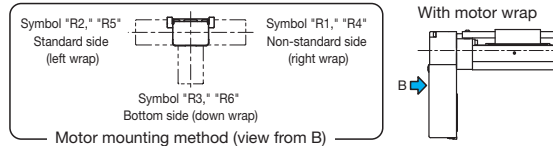

Selection Materials

Basic Specifications

LM Guide	Basic dynamic load rating C (N)		28,400
	Basic static load rating C_0 (N)		28,700
	Radial clearance (mm)	Normal grade/High accuracy grade (H)	-0.006 to 0
		Precision grade (P)	-0.016 to -0.006
	Geometric moment of inertia	I_x^1 (mm ⁴)	2.05×10^6
I_y^2 (mm ⁴)		1.45×10^6	
Mass (kg/m)		12.6	
Ball screw	Ball screw lead (mm)		10 20
	Basic dynamic load rating C_a (N)	Normal grade/High accuracy grade (H)	4,350
		Precision grade (P)	4,240
	Basic static load rating C_{0a} (N)	Normal grade/High accuracy grade (H)	6,990
		Precision grade (P)	7,040
	Screw shaft diameter (mm)		Ø15
	Thread minor diameter (mm)		Ø12.4
Ball center-to-center diameter (mm)		Ø15.75	
Permissible rotational speed ³ (min ⁻¹)	Normal grade/High accuracy grade (H)	6,000	
	Precision grade (P)	6,000	
Bearing (Fixed side)	Axial direction	Basic dynamic load rating C_a (N)	6,700
		Static permissible load P_{0a} (N)	3,330
Permissible input torque (N·m)	Direct coupling	5.3	
	Motor wrap	4.5	
Static permissible moment ^{4,5} (N·m)		M_A : 236 (1,460), M_B : 236 (1,460), M_C : 870 (1,740)	
Running life ⁶ (km)		10,000	
Standard grease/Grease nipple used		THK AFB-LF Grease/A-M6F	

¹ I_x is the geometric moment of inertia about the X axis.
² I_y is the geometric moment of inertia about the Y axis.
³ The permissible rotational speed may decrease as the stroke becomes longer.
⁴ The value in parentheses is with 2 short blocks (D type) attached.
⁵ See p. 116 for the values if "1" or "2" is selected for item ⑧ in the Model Number Coding.
⁶ Calculated under the following conditions.
 Stroke: 520 mm (C type), 445 mm (D type) / Speed: 500 mm/s (for 10 mm lead), 1,000 mm/s (for 20 mm lead) / Load mass: Maximum load capacity (p. 9) / Acceleration/deceleration: As when set to maximum load capacity (p. 9) / Center of gravity: Center of the table's upper surface.
 Notes: 1. Customized products can also be made to handle special environments or large axial loads (25% or more of the basic dynamic load rating C_a). Consult with THK.
 2. LM Guide load rating is the load rating per short block.

Accuracy

Accuracy grade	Item	Stroke ⁷					
		220	320	420	520	620	720
Normal grade (no symbol)	Positioning repeatability (mm)	±0.01					
	Positioning accuracy (mm)	Not specified					
	Running parallelism (vertical direction) (mm)	Not specified					
	Backlash (mm)	0.02					
	Starting torque (N·cm)	10					
High accuracy grade (H)	Positioning repeatability (mm)	±0.005					
	Positioning accuracy (mm)	0.1		0.12		0.15	
	Running parallelism (vertical direction) (mm)	0.035		0.04		0.05	
	Backlash (mm)	0.02					
	Starting torque (N·cm)	10					
Precision grade (P)	Positioning repeatability (mm)	±0.003					
	Positioning accuracy (mm)	0.025		0.03			
	Running parallelism (vertical direction) (mm)	0.015		0.02			
	Backlash (mm)	0.003					
	Starting torque (N·cm)	15		17			

⁷ Stroke with 1 short block (C type, without QZ).
 Notes: 3. Precision evaluation in accordance with THK standards.
 4. Measured using a motor for inspection. With motor wrap specifications, measurements are not made in the completed motor wrap state.
 5. The starting torque represents the value when containing THK AFB-LF Grease.
 6. The starting torque may exceed standards if using vacuum grease, clean room grease, or other high-viscosity greases, so care should be taken when selecting a motor.
 7. Contact THK for accuracy higher than the standard stroke.

Geometric Moment of Inertia

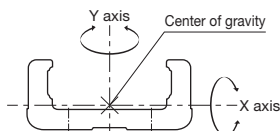

Static Permissible Moment

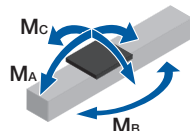

Motor Selection Information

Stroke ¹ (mm)	Outer rail length (mm)	LM Guide				Ball screw		Motor mounting part	
		Moving part mass (kg)			Sliding resistance value ² (N)	Lead (mm)	Shaft length (mm)	Direct coupling	Motor wrap
		Block mass	Sub-table mass	Total mass				Shaft end diameter (mm)	Timing pulley (sum of two) Inertial moment x 10 ⁻⁴ (kg·m ²)
220 to 820	340 to 940	C type: 0.6 D type: 1.2	C type: 0.2 D type: 0.4	C type: 0.8 D type: 1.6	4.1	10, 20	405 to 1,005	Ø10h7	0.86

¹ Stroke with 1 short block (C type, without QZ).

² Value with 1 short block (C type, without QZ). This value is the sum of the rolling resistance value and seal resistance value.

Note: Refer to p. 73 for applicable couplings.

Permissible Overhang Length³

Horizontal

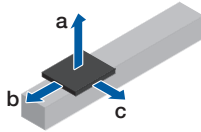

Wall-Mounted

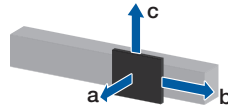

Vertical

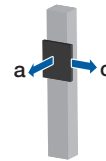

Estimated motor capacity 200 W	Ball screw lead (mm)	Load mass (kg)	a (mm)	b (mm)	c (mm)	
Direct coupling	C type	10	13.5	130	40	40
			27.5	40	20	20
		55.5	0	10	10	
		20	6	330	110	100
			12.5	140	50	50
	D type	10	25.5	50	20	20
			19.5	330	110	60
		39.5	140	50	30	
		20	79	50	20	10
			5.5	860	390	230
Motor wrap	C type	10	13.5	130	40	40
			27.5	40	20	20
		55.5	0	10	10	
		20	4	520	160	160
			8	240	80	80
	D type	10	16	100	40	40
			19.5	330	110	60
		39.5	140	50	30	
		20	79	50	20	10
			4	860	540	320
20	8	860	270	160		
	16.5	400	130	70		

Estimated motor capacity 200 W	Ball screw lead (mm)	Load mass (kg)	a (mm)	b (mm)	c (mm)	
Direct coupling	C type	10	13.5	0	70	240
			27.5	0	30	110
		55.5	0	10	50	
		20	6	60	160	540
			12.5	0	70	260
	D type	10	25.5	0	30	120
			19.5	20	150	510
		39.5	0	70	250	
		20	79	0	30	120
			5.5	190	540	860
Motor wrap	C type	10	13.5	0	70	240
			27.5	0	30	110
		55.5	0	10	50	
		20	4	110	240	810
			8	30	120	400
	D type	10	16	0	60	200
			19.5	20	150	510
		39.5	0	70	250	
		20	79	0	30	120
			4	280	740	860
8	120	370	860			
16.5	30	180	600			

Estimated motor capacity 200 W	Ball screw lead (mm)	Load mass (kg)	a (mm)	c (mm)	
Direct coupling	C type	10	3	130	250
			6.5	40	110
		13	0	50	
		20	1	480	750
			2.5	170	300
	D type	10	5.5	50	130
			4.5	330	510
		20	9	140	250
			18	50	120
		2	790	860	
Motor wrap	C type	10	3	130	250
			6.5	40	110
		13	0	50	
		20	1	480	750
			2.5	170	300
	D type	10	5.5	50	130
			3.5	440	650
		20	7.5	180	300
			15.5	70	140
		2	790	860	
4	380	570			
8	170	280			

Estimated motor capacity 400 W	Ball screw lead (mm)	Load mass (kg)	a (mm)	b (mm)	c (mm)	
Direct coupling	C type	10	17	90	30	30
			34.5	20	10	10
		69.5	0	0	0	
		20	9.5	200	70	60
			19	80	30	30
	D type	10	38	20	10	10
			24.5	250	80	50
		49	110	40	20	
		20	98.5	30	20	10
			13	520	160	90
Motor wrap	C type	10	17	90	30	30
			34.5	20	10	10
		69.5	0	0	0	
		20	9.5	200	70	60
			19	80	30	30
	D type	10	38	20	10	10
			24.5	250	80	50
		49	110	40	20	
		20	98.5	30	20	10
			11.5	590	180	110
23.5	270	90	50			
47	110	40	20			

Estimated motor capacity 400 W	Ball screw lead (mm)	Load mass (kg)	a (mm)	b (mm)	c (mm)	
Direct coupling	C type	10	13.5	0	70	240
			27.5	0	30	110
		55.5	0	10	50	
		20	7.5	40	130	430
			15.5	0	60	210
	D type	10	31	0	30	100
			19.5	20	150	510
		39.5	0	70	250	
		20	79	0	30	120
			13	50	220	760
Motor wrap	C type	10	13.5	0	70	240
			27.5	0	30	110
		55.5	0	10	50	
		20	7.5	40	130	430
			15.5	0	60	210
	D type	10	31	0	30	100
			19.5	20	150	510
		39.5	0	70	250	
		20	79	0	30	120
			11.5	70	250	860
23.5	10	120	420			
47	0	60	210			

Estimated motor capacity 400 W	Ball screw lead (mm)	Load mass (kg)	a (mm)	c (mm)	
Direct coupling	C type	10	4	90	180
			8	20	90
		16.5	0	40	
		20	3	130	250
			6.5	40	110
	D type	10	13	0	50
			5.5	260	410
		20	11.5	100	190
			23.5	30	90
		4.5	330	510	
Motor wrap	C type	10	4	90	180
			8	20	90
		16.5	0	40	
		20	3	130	250
			6.5	40	110
	D type	10	13	0	50
			3.5	440	650
		20	7.5	180	300
			15.5	70	140
		3.5	440	650	
7.5	180	300			
15.5	70	140			

³ This is the value with the service life of the LM Guide limited to 10,000 km. The calculation conditions are as follows.

Stroke: 520 mm (C type), 445 mm (D type) / Acceleration/deceleration: 0.3 G / Speed: 500 mm/s (for 10 mm lead), 1,000 mm/s (for 20 mm lead) / Overhang direction: Loaded in only a single direction. Dimensions a, b, and c are from the center of the table's upper surface.

With Cover
Direct Motor Coupling

Dimensions

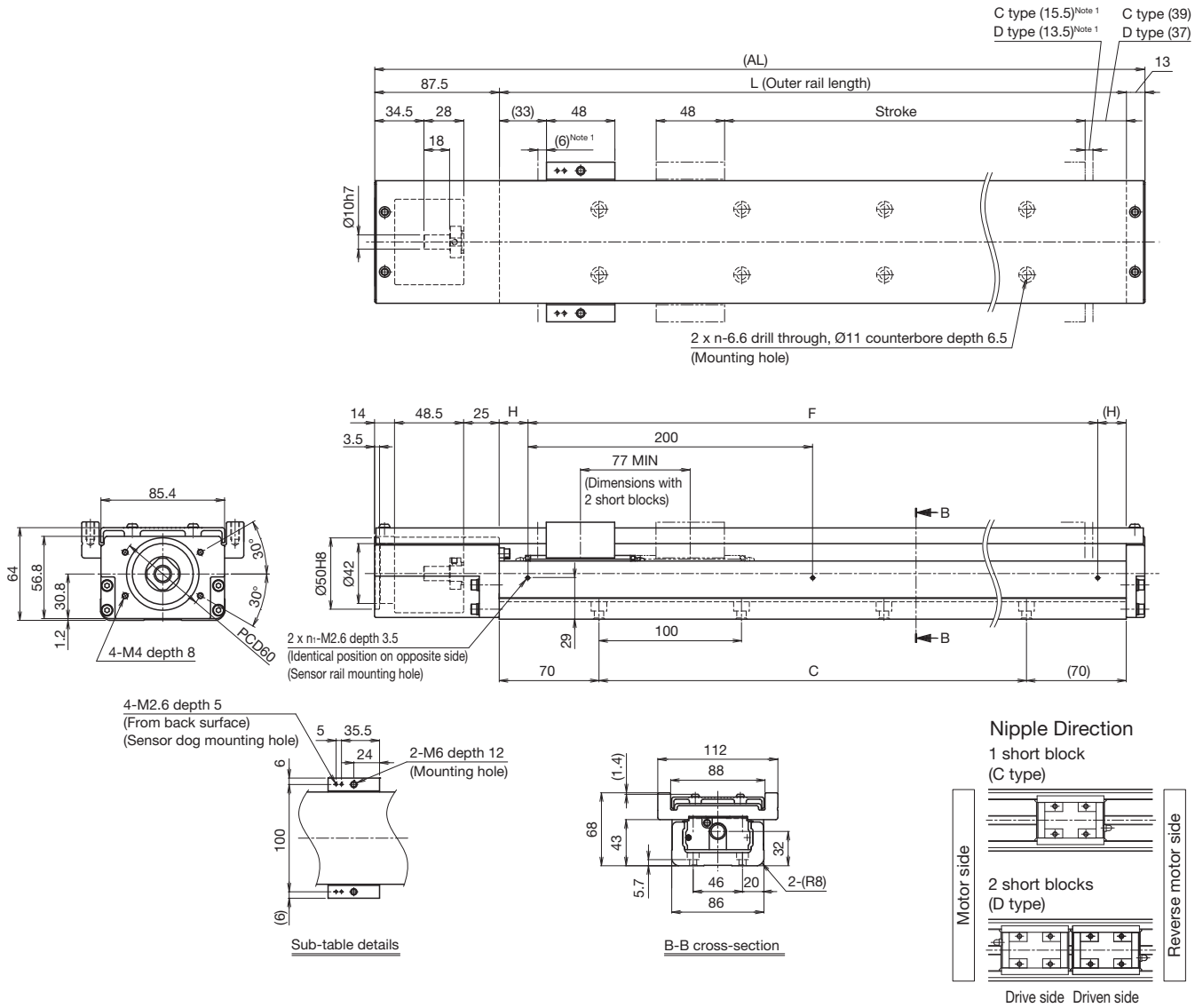

¹ Dimensions from the mechanical stopper to the stroke start position.

Stroke (mm) (Stroke between mechanical stoppers)	C type	220 (241.5)	320 (341.5)	420 (441.5)	520 (541.5)	620 (641.5)	720 (741.5)	820 (841.5)
	D type ²	145 (164.5)	245 (264.5)	345 (364.5)	445 (464.5)	545 (564.5)	645 (664.5)	745 (764.5)
Maximum speed ³ (mm/s)	Ball screw lead: 10 mm		1,000		910	660	500	400
	Ball screw lead: 20 mm		2,000		1,770	1,300	990	780
Dimensions (mm)	AL	440.5	540.5	640.5	740.5	840.5	940.5	1,040.5
	L	340	440	540	640	740	840	940
	C	200	300	400	500	600	700	800
	F	200	400	400	600	600	800	800
	H	70	20	70	20	70	20	70
No. of mounting holes	n	3	4	5	6	7	8	9
	n ₁	2	3	3	4	4	5	5
Mass ⁴ (kg)		7.1	8.6	10.1	11.6	13.1	14.6	16.1

² The value with 2 short blocks (D type, without QZ) attached.

³ The maximum speed is restricted by the actuator's permissible speed.

⁴ The mass with 2 short blocks (D type) has 0.8 kg added.

Without Cover
Direct Motor Coupling

Dimensions

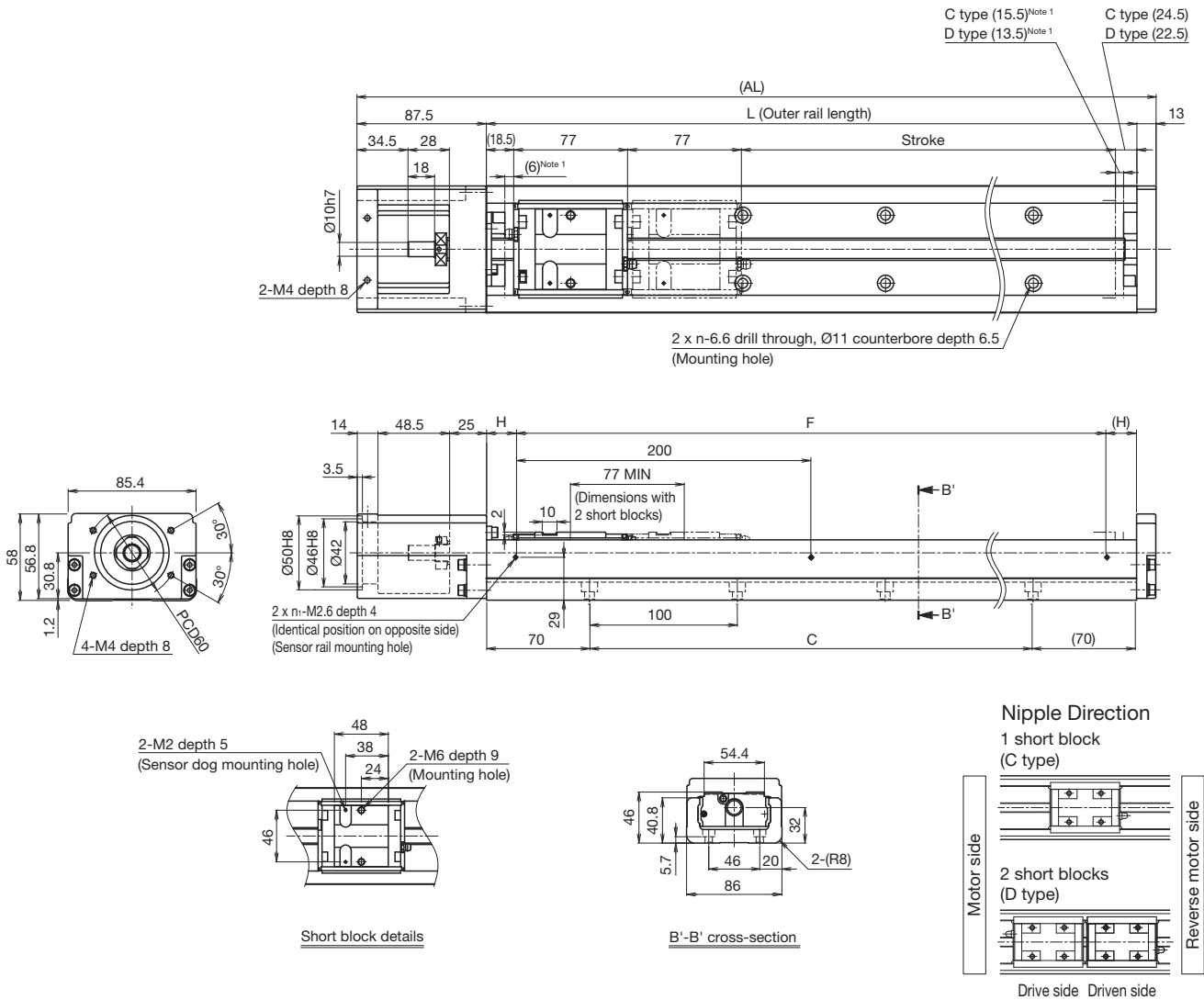

¹ Dimensions from the mechanical stopper to the stroke start position.

Stroke (mm) (Stroke between mechanical stoppers)	C type	220 (241.5)	320 (341.5)	420 (441.5)	520 (541.5)	620 (641.5)	720 (741.5)	820 (841.5)
	D type ²	145 (164.5)	245 (264.5)	345 (364.5)	445 (464.5)	545 (564.5)	645 (664.5)	745 (764.5)
Maximum speed ³ (mm/s)	Ball screw lead: 10 mm		1,000		910	660	500	400
	Ball screw lead: 20 mm		2,000		1,770	1,300	990	780
Dimensions (mm)	AL	440.5	540.5	640.5	740.5	840.5	940.5	1,040.5
	L	340	440	540	640	740	840	940
	C	200	300	400	500	600	700	800
	F	200	400	400	600	600	800	800
	H	70	20	70	20	70	20	70
No. of mounting holes	n	3	4	5	6	7	8	9
	n ₁	2	3	3	4	4	5	5
Mass ⁴ (kg)		6.3	7.7	9.1	10.5	11.9	13.4	14.8

² The value with 2 short blocks (D type, without QZ) attached.
³ The maximum speed is restricted by the actuator's permissible speed.
⁴ The mass with 2 short blocks (D type) has 0.6 kg added.

With Cover
Motor Wrap

Dimensions

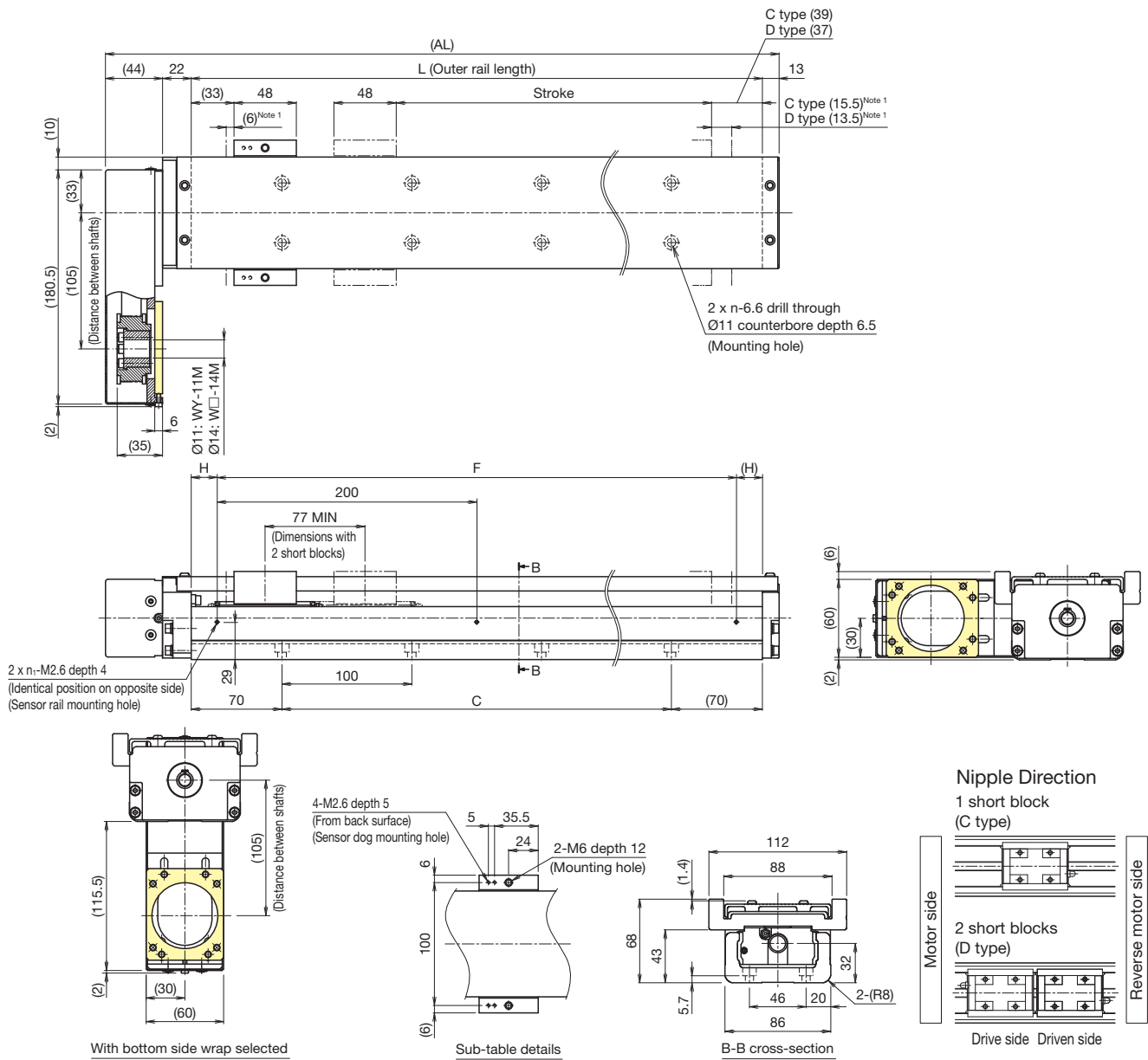

¹ Dimensions from the mechanical stopper to the stroke start position.

Stroke (mm) (Stroke between mechanical stoppers)	C type	220 (241.5)	320 (341.5)	420 (441.5)	520 (541.5)	620 (641.5)	720 (741.5)	820 (841.5)
	D type ²	145 (164.5)	245 (264.5)	345 (364.5)	445 (464.5)	545 (564.5)	645 (664.5)	745 (764.5)
Maximum speed ³ (mm/s)	Ball screw lead: 10 mm	1,000			910	660	500	400
	Ball screw lead: 20 mm	2,000			1,770	1,300	990	780
Dimensions (mm)	AL	419	519	619	719	819	919	1,019
	L	340	440	540	640	740	840	940
	C	200	300	400	500	600	700	800
	F	200	400	400	600	600	800	800
	H	70	20	70	20	70	20	70
No. of mounting holes	n	3	4	5	6	7	8	9
	n ₁	2	3	3	4	4	5	5
Mass ⁴ (kg)		8	9.5	11	12.5	14	15.5	17

² The value with 2 short blocks (D type, without QZ) attached.

³ The maximum speed is restricted by the actuator's permissible speed.

⁴ The mass with 2 short blocks (D type) has 0.8 kg added.

Without Cover
Motor Wrap

Dimensions

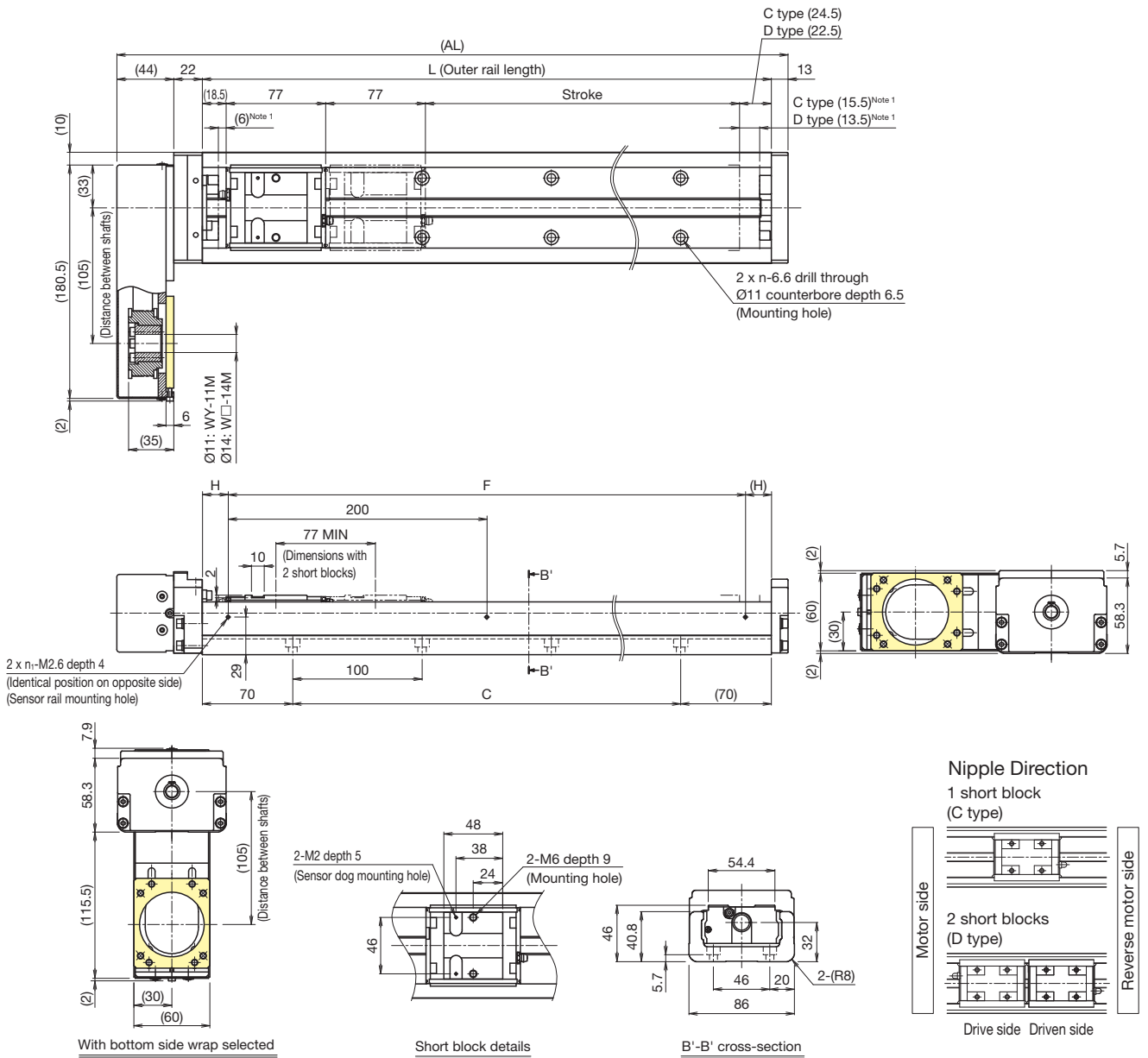

¹ Dimensions from the mechanical stopper to the stroke start position.

Stroke (mm) (Stroke between mechanical stoppers)	C type	220 (241.5)	320 (341.5)	420 (441.5)	520 (541.5)	620 (641.5)	720 (741.5)	820 (841.5)
	D type ²	145 (164.5)	245 (264.5)	345 (364.5)	445 (464.5)	545 (564.5)	645 (664.5)	745 (764.5)
Maximum speed ³ (mm/s)	Ball screw lead: 10 mm	1,000			910	660	500	400
	Ball screw lead: 20 mm	2,000			1,770	1,300	990	780
Dimensions (mm)	AL	419	519	619	719	819	919	1,019
	L	340	440	540	640	740	840	940
	C	200	300	400	500	600	700	800
	F	200	400	400	600	600	800	800
	H	70	20	70	20	70	20	70
No. of mounting holes	n	3	4	5	6	7	8	9
	n ₁	2	3	3	4	4	5	5
Mass ⁴ (kg)		7.3	8.7	10.1	11.5	12.9	14.3	15.7

² The value with 2 short blocks (D type, without QZ) attached.
³ The maximum speed is restricted by the actuator's permissible speed.
⁴ The mass with 2 short blocks (D type) has 0.6 kg added.

Options

Sensors

Optional photo sensors and proximity sensors are available. Sensor-equipped models also feature a dedicated sensor rail and sensor dog.

Sensors, sensor rails, and sensor dogs can be mounted on both sides when the stroke is less than 70 mm.

Mounting example

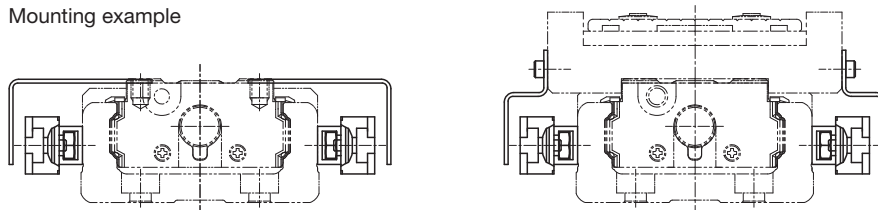

Symbol	Description	Model	Accessories
0	None	-	-
1	With sensor rail	-	Mounting screws, sensor rail (x1 or 2)
2	Photo sensor ¹ (x3)	EE-SX671 (OMRON Corporation)	Mounting screws, nuts, sensor dog (x1 or 2), sensor rail (x1 or 2), mounting plates (x3), connectors (EE-1001 x3)
6	Photo sensor ¹ (x3)	EE-SX674 (OMRON Corporation)	Mounting screws, nuts, sensor dog (x1 or 2), sensor rail (x1 or 2), mounting plates (x3), connectors (EE-1001 x3)
7	Proximity sensor N.O. contact ² (x3)	APM-D3A1-001 (Azbil Corporation)	Mounting screws, nuts, sensor dog (x1 or 2), sensor rail (x1 or 2)
B	Proximity sensor N.C. contact ³ (x3)	APM-D3B1-003 (Azbil Corporation)	Mounting screws, nuts, sensor dog (x1 or 2), sensor rail (x1 or 2)
E	Proximity sensor N.O. contact ² (x1) N.C. contact ³ (x2)	APM-D3A1-001 (Azbil Corporation) APM-D3B1-003 (Azbil Corporation)	Mounting screws, nuts, sensor dog (x1 or 2), sensor rail (x1 or 2)
H	Proximity sensor N.O. contact ² (x3)	GX-F12A (Panasonic Industry Co., Ltd.)	Mounting screws, nuts, sensor dog (x1 or 2), sensor rail (x1 or 2)
L	Proximity sensor N.C. contact ³ (x3)	GX-F12B (Panasonic Industry Co., Ltd.)	Mounting screws, nuts, sensor dog (x1 or 2), sensor rail (x1 or 2)
J	Proximity sensor N.O. contact ² (x1) N.C. contact ³ (x2)	GX-F12A (Panasonic Industry Co., Ltd.) GX-F12B (Panasonic Industry Co., Ltd.)	Mounting screws, nuts, sensor dog (x1 or 2), sensor rail (x1 or 2)
M	Proximity sensor N.O. contact ² (x1) (PNP output) N.C. contact ³ (x2) (PNP output)	GX-F12A-P (Panasonic Industry Co., Ltd.) GX-F12B-P (Panasonic Industry Co., Ltd.)	Mounting screws, nuts, sensor dog (x1 or 2), sensor rail (x1 or 2)

¹ The photo sensors can be switched between ON when lit and ON when unlit.

² N.O. contact: Normally open contact point

³ N.C. contact: Normally closed contact point

Notes: 1. If proximity sensors are close to one another, they may not function properly. If that happens, please prepare a type with a different frequency.

2. Mounting of sensors other than those in the table above is possible. Contact THK for details.

Sensor Rail Mounting Dimensions

Mounting only a sensor rail is also possible.

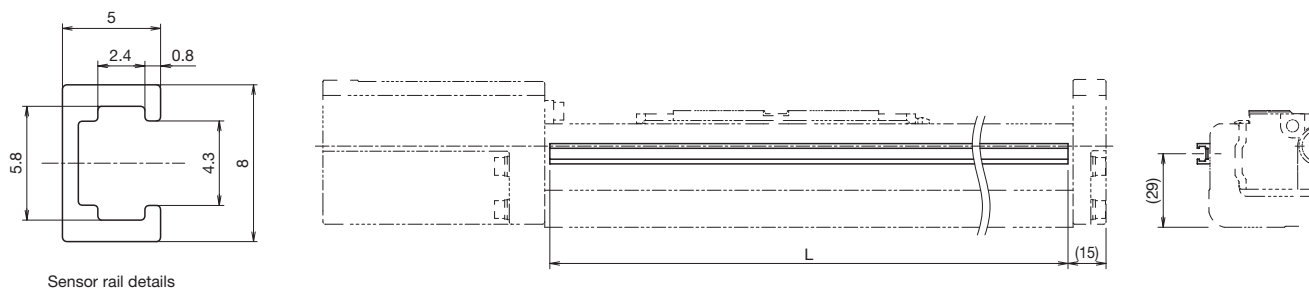

Sensor rail details

Stroke ⁴ (mm)	Outer rail length (mm)	L (mm)
190	340	336
290	440	436
390	540	536
490	640	636
590	740	736
690	840	836
790	940	936

⁴ Stroke with 1 block (A type).

Photo Sensor Mounting Dimensions

Connector: EE-1001 (OMRON Corporation) x3 included.
To be mounted by the customer.

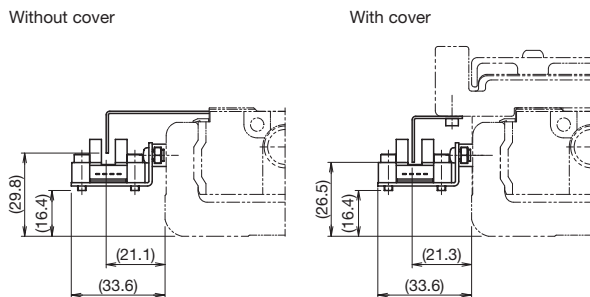

Symbol	Model	Manufacturer
2	EE-SX671	OMRON Corporation

Sensor dog width: 10 mm

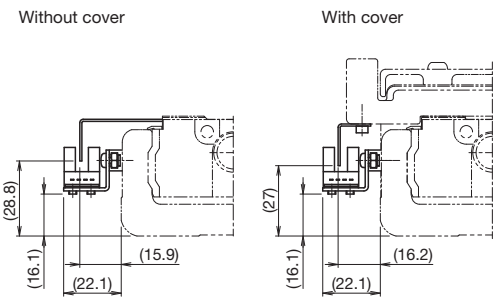

Symbol	Model	Manufacturer
6	EE-SX674	OMRON Corporation

Sensor dog width: 10 mm

Proximity Sensor Mounting Dimensions

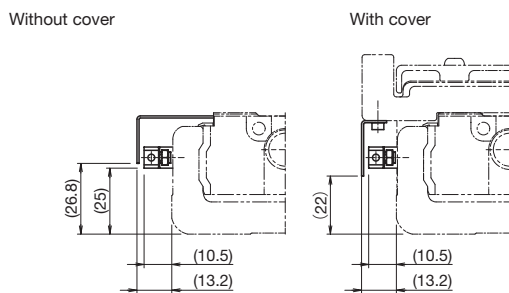

Symbol	Model	Manufacturer
7, B, E	APM-D3A1-001	Azbil Corporation
	APM-D3B1-003	

Sensor dog width: 10 mm

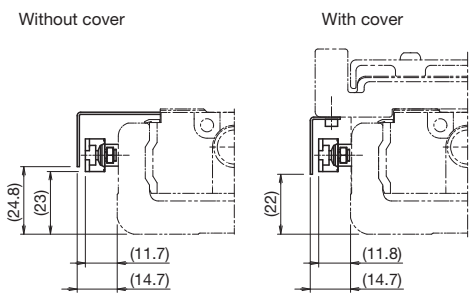

Symbol	Model	Manufacturer
H, L, J	GX-F12A	Panasonic Industry Co., Ltd.
	GX-F12B	
M	GX-F12A-P	
	GX-F12B-P	

Sensor dog width: 10 mm

Mounting Dimensions with Bellows

Photo sensor

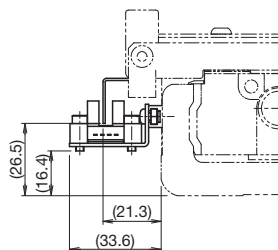

Symbol	Model	Manufacturer
2	EE-SX671	OMRON Corporation

Sensor dog width: 10 mm

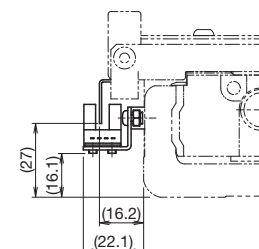

Symbol	Model	Manufacturer
6	EE-SX674	OMRON Corporation

Sensor dog width: 10 mm

Proximity sensor

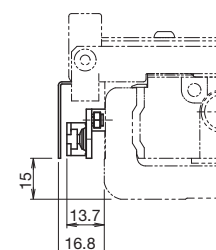

Symbol	Model	Manufacturer
7, B, E	APM-D3A1-001	Azbil Corporation
	APM-D3B1-003	

Sensor dog width: 10 mm

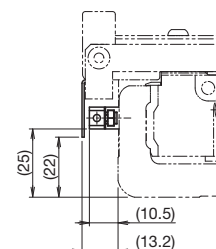

Symbol	Model	Manufacturer
H, L, J	GX-F12A	Panasonic Industry Co., Ltd.
	GX-F12B	
M	GX-F12A-P	
	GX-F12B-P	

Sensor dog width: 10 mm

Options

Intermediate Flange (Direct Coupling)

Several types of intermediate flanges for mounting motors are available.

When selecting "0" or "1" for Model Number Coding ⑦ With/without motor, specify an intermediate flange that matches the motor used.

Compatibility Table: Motors Used, Intermediate Flanges, and Couplings

Motor type	Manufacturer	Motor model		Motor rated output (W)	Flange size	Housing A/ Intermediate flange	Compatible coupling models		
							MIKI PULLEY CO., LTD.	Nabeya Bi-tech Kaisha (NBK)	
AC servo motor	YASKAWA Electric Corporation	Σ-V	SGMJV-02	200	60×60	AV	SFC-030DA2-10B-14B	XGT2-27C-10-14	
			SGMAV-02						
			SGMJV-04						
			SGMAV-04						
			SGMJV-06						
		Σ-7	SGM7J-02	200	60×60	AV	SFC-030DA2-10B-14B	XGT2-27C-10-14	
			SGM7A-02						
			SGM7J-04						
			SGM7A-04						
			SGM7J-06						
			SGM7A-06						
		Σ-X	SGMXJ-02	200	60×60	AV	SFC-030DA2-10B-14B	XGT2-27C-10-14	
			SGMXA-02						
			SGMXJ-04						
			SGMXA-04						
	SGMXJ-06								
	SGMXA-06								
	Mitsubishi Electric Corporation	MELSERVO	J4	HG-KR23	200	60×60	AV	SFC-030DA2-10B-14B	XGT2-27C-10-14
				HG-MR23					
				HG-KR43					
			J5	HK-KT23W	200	60×60	AV	SFC-030DA2-10B-14B	XGT2-27C-10-14
				HK-KT43W					
				HF-KN23					
		JN	HF-KN43	200	60×60	AV	SFC-030DA2-10B-14B	XGT2-27C-10-14	
			HF-KN43						
			HF-KN43						
	TAMAGAWA SEIKI CO., LTD.	TBL-III	TS4607	200	60×60	AV	SFC-030DA2-10B-14B	XGT2-27C-10-14	
			TS4609						
		TBL-IV	TSM3202	200	60×60	AV	SFC-030DA2-10B-14B	XGT2-27C-10-14	
			TSM3204						
	Panasonic Corporation	MINAS	A5	MSMD02	200	60×60	AY	SFC-030DA2-10B-11B	XGT2-30C-10-11
				MSME02					
				MSMD04					
				MSME04					
		A6	MSMF02	200	60×60	AY	SFC-030DA2-10B-11B	XGT2-30C-10-11	
			MHMF02						
			MSMF04						
			MHMF04						
	KEYENCE CORPORATION	SV	SV-M020	200	60×60	AV	SFC-030DA2-10B-14B	XGT2-27C-10-14	
			SV-M040						
		SV2	SV2-M020	200	60×60	AV	SFC-030DA2-10B-14B	XGT2-27C-10-14	
			SV2-M040						
SANYO DENKI CO., LTD.	SANMOTION R	R2□A06020	200	60×60	AV	SFC-030DA2-10B-14B	XGT2-27C-10-14		
		R2AA06040							
OMRON Corporation	OMNUC G5	R88M-K20030	200	60×60	AY	SFC-030DA2-10B-11B	XGT2-30C-10-11		
		R88M-K40030							
	1S	R88M-1M20030	200	60×60	AY	SFC-030DA2-10B-11B	XGT2-30C-10-11		
		R88M-1M40030							

Motor type	Manufacturer	Motor model		Flange size	Housing A/ Intermediate flange	Compatible coupling models		
						MIKI PULLEY CO., LTD.	Nabeya Bi-tech Kaisha (NBK)	
Stepper motor	ORIENTAL MOTOR CO., LTD.	α step	AZ6*, AR6*	60×60	AU	SFC-025DA2-10B-10B-L46	XGL2-25C-10-10	
			CRK ¹					CRK56* (CRK569PM*)
		5-phase	RK II	RKS56*	60×60	AU	SFC-025DA2-10B-10B-L46	XGL2-25C-10-10
			PKP ¹	PKP56* (PKP569FM*)	60×60	AU	SFC-025DA2-8B-10B-L46 (SFC-025DA2-10B-10B-L46)	XGL2-25C-8-10 (XGL2-25C-10-10)
	KEYENCE CORPORATION	2-phase	QS-M60	60×60	AU	SFC-025DA2-8B-10B-L46	XGL2-25C-8-10	
	SANYO DENKI CO., LTD.	PB	PBDM60*, PBA**60*	60×60	AU	SFC-025DA2-10B-10B-L46	XGL2-25C-10-10	
		5-phase	FAM56*/FDM56*/ FA512M60/FB512M60	60×60	AU	SFC-025DA2-10B-10B-L46	XGL2-25C-10-10	
		2-phase	DB16H78*	60×60	AU	SFC-025DA2-8B-10B-L46	XGL2-25C-8-10	

¹ Items in parentheses have different motor shaft diameters and require a coupling to be specified.

Notes: 1. The table shows only a portion of the model numbers for motors. For details regarding model numbers, please see the catalog for each respective motor manufacturer.

2. If the maximum torque for motors exceeds the permissible input torque (A/B → p. 59, C/D → p. 65), please consider a safety measure to limit the torque.

3. When installing a motor other than the motor model numbers listed above, contact THK.

Housing A

SKR46
A0

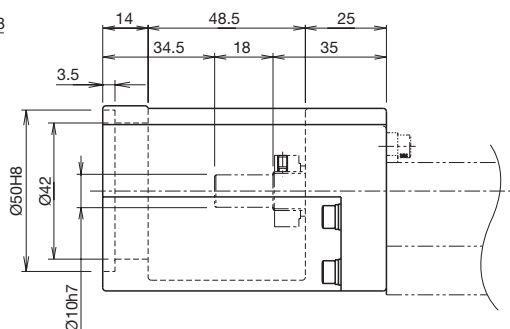
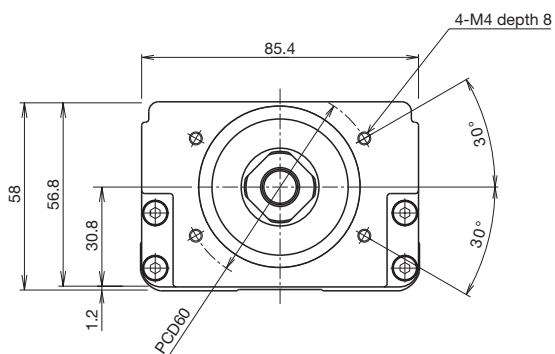

SKR**	Actuator model
●◇	●: Housing A ◇: Intermediate flange

Intermediate Flange

SKR46
AU

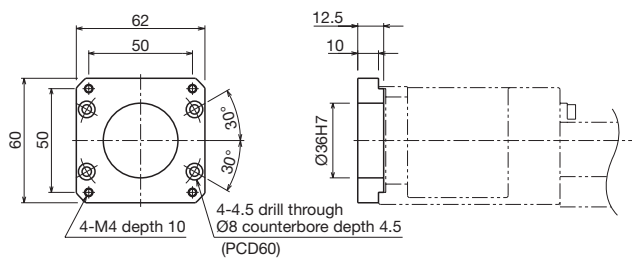

SKR46
AY

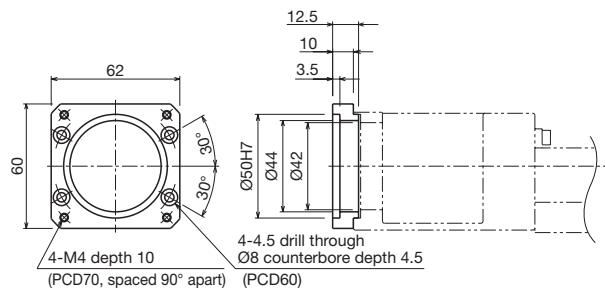

SKR46
AV

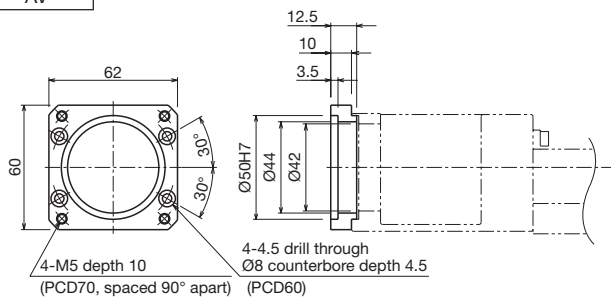

Options

Intermediate Flange (Motor Wrap)

Several types of intermediate flanges for mounting motors are available.

When selecting "R1," "R2," "R3," "R4," "R5," or "R6" for Model Number Coding ⑦ With/without motor, specify an intermediate flange that matches the motor used.

Symbol Coding

Motor wrap symbol ①	Intermediate flange ②	Motor shaft diameter (mm) ③	Motor shaft securing method ④
W	V	14	M
W	Refer to the Compatibility Table: Motors Used and Motor Wrap Symbols below.	Specify a motor shaft diameter. (Refer to the Compatibility Table: Motors Used and Motor Wrap Symbols below.)	M: Friction tightening tool

Motor Shaft Securing Method

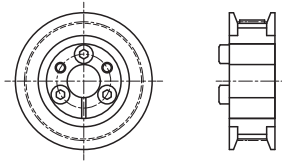

Friction tightening tool

Compatibility Table: Motors Used and Motor Wrap Symbols

Motor type	Manufacturer	Motor model	Motor rated output (W)	Flange size	Housing A/Intermediate flange		
AC servo motor	YASKAWA Electric Corporation	Σ-V	SGMJV-02	200	60×60	WV-14M	
			SGMAV-02	400			
			SGMJV-04				
			SGMAV-04				
		Σ-7	SGM7J-02		200		60×60
			SGM7A-02	400			
			SGM7J-04				
			SGM7A-04				
		Σ-X	SGMXJ-02		200		60×60
	SGMXA-02						
	SGMXJ-04						
	SGMXA-04						
	Mitsubishi Electric Corporation	MELSERVO	J4	HG-MR23	200	60×60	
				HG-KR23			
				HG-MR43			
			J5	HK-KT23W	200		60×60
				HK-KT43W			
				400			
	JN	HF-KN23	200	60×60			
		400					
	TAMAGAWA SEIKI CO., LTD.	TBL-III	TS4607	200	60×60		
			400				
		TBL-IIV	TSM3202	200		60×60	
			400				
	Panasonic Corporation	MINAS	A5	MSMD02	200	60×60	
				MSME02			
				MSMD04			
			A6	MSME04	400		60×60
				MSMF02			
				MHMF02			
KEYENCE CORPORATION		SV	SV-M020	200	60×60		
			400				
		SV2	SV2-M020	200		60×60	
			400				
SANYO DENKI CO., LTD.	SANMOTION R	R2□A06020	200	60×60			
		400					
OMRON Corporation	OMNUC G5	R88M-K20030	200	60×60			
		R88M-K40030	400				
	1S	R88M-1M20030	200		60×60		
		R88M-1M40030	400				

Notes: 1. The table shows only a portion of the model numbers for motors. For details regarding model numbers, please see the catalog for each respective motor manufacturer.
 2. If the maximum torque for motors exceeds the permissible input torque (A/B → p. 59, C/D → p. 65), please consider a safety measure to limit the torque.
 3. When installing a motor other than the motor model numbers listed above, contact THK.

Motor Wrap Housing A

SKR46
60

SKR**	Actuator model
●◇	●: Housing A ◇: Intermediate flange

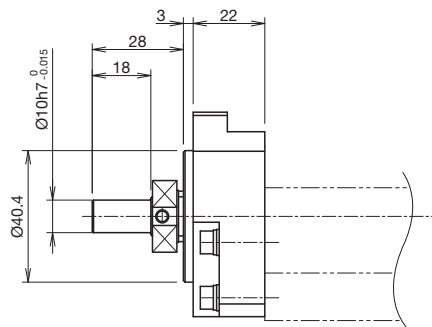
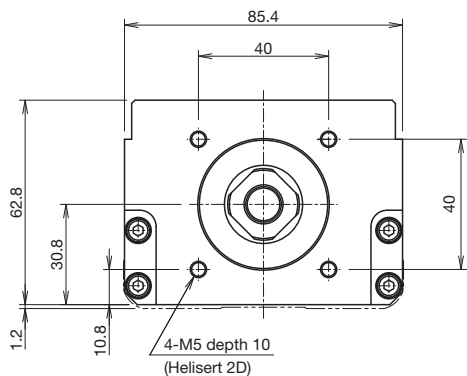

Motor Wrap Specification (Intermediate Flange)

SKR46
WV

Thickness: 6 mm

SKR46
WY

Thickness: 6 mm

SKR**	Actuator model
W□	□: Intermediate flange

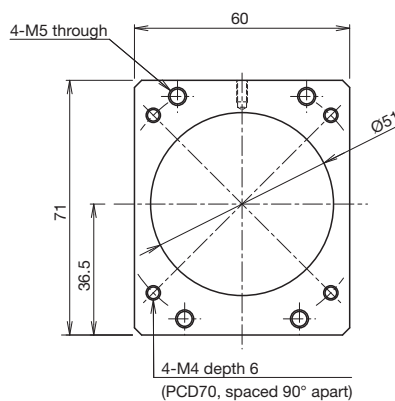
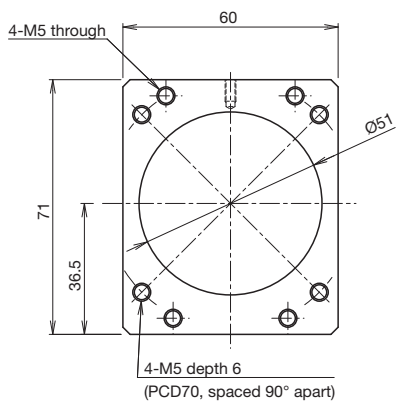

Options

QZ Lubricator

The QZ Lubricator for SKR feeds the right amount of lubricant to the outer rail and ball screw shaft raceways. This allows an oil film to be constantly formed between the balls and the raceway, and it significantly extends the lubrication maintenance interval.

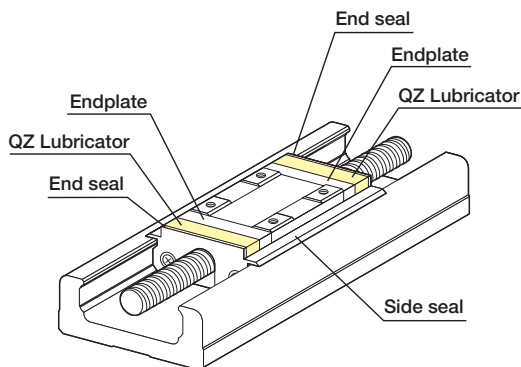

Appearance

Features

- Since it compensates for oil loss, the lubrication maintenance interval can be significantly extended.
- It is an eco-friendly lubrication system that does not contaminate the surrounding area, as it feeds the right amount of lubricant to the ball raceway.

QZ Configuration

Symbol	Block type	Description
QZ	A/B/C/D	QZ all-block double-sided specification
QZA	A/C	QZ fixed side specification
QZB	A/C	QZ supported side specification
QZAD	B/D	QZ fixed side (drive side block) + QZ supported side (driven side block) specification

Note: QZ specification types do not have a grease nipple mounted. Contact THK if a grease nipple is required.

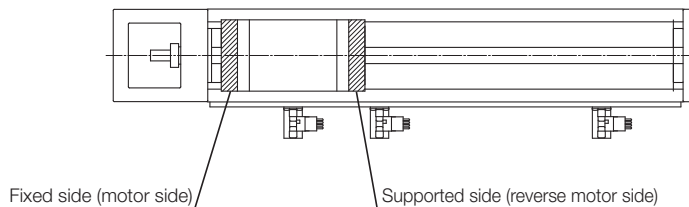

Block type \ QZ configuration	QZ	QZA	QZB	QZAD
A type (1 block)	 Fixed side Supported side	 Fixed side Supported side	 Fixed side Supported side	-
B type (2 blocks)	 Fixed side Supported side	-	-	 Fixed side Supported side
C type (1 short block)	 Fixed side Supported side	 Fixed side Supported side	 Fixed side Supported side	-
D type (2 short blocks)	 Fixed side Supported side	-	-	 Fixed side Supported side

Dimensions with QZ Lubricator

QZ (With Cover)

Block Type: A/B/C/D

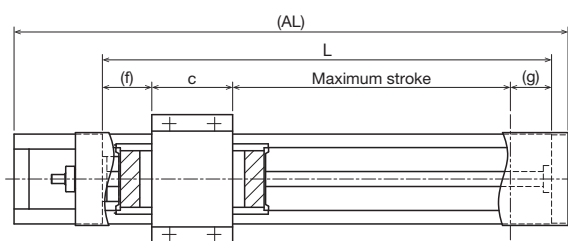

Block Type A/C

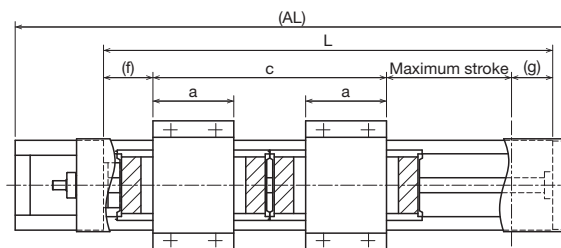

Block Type B/D

Unit: mm

Block type	Overall length AL	Outer rail length L	Stroke ¹	Maximum stroke ¹	a	c	f	g
A	440.5	340	160	178.5	-	81	42	38.5
	540.5	440	260	278.5				
	640.5	540	360	378.5				
	740.5	640	460	478.5				
	840.5	740	560	578.5				
	940.5	840	660	678.5				
1,040.5	940	760	778.5					
B	540.5	440	120	138.5	81	221	42	38.5
	640.5	540	220	238.5				
	740.5	640	320	338.5				
	840.5	740	420	438.5				
	940.5	840	520	538.5				
1,040.5	940	620	638.5					
C	440.5	340	190	211.5	-	48	42	38.5
	540.5	440	290	311.5				
	640.5	540	390	411.5				
	740.5	640	490	511.5				
	840.5	740	590	611.5				
	940.5	840	690	711.5				
1,040.5	940	790	811.5					
D	440.5	340	85	104.5	48	155	42	38.5
	540.5	440	185	204.5				
	640.5	540	285	304.5				
	740.5	640	385	404.5				
	840.5	740	485	504.5				
	940.5	840	585	604.5				
	1,040.5	940	685	704.5				

¹ The value for B/D block types is with 2 blocks attached.

Options

Dimensions with QZ Lubricator

QZ (Without Cover)
Block Type: A/B/C/D

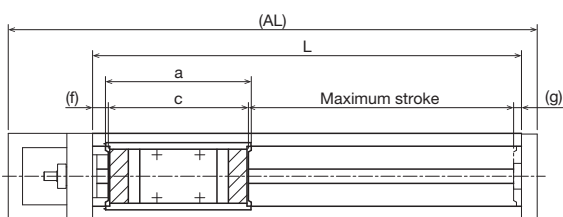

Block Type A/C

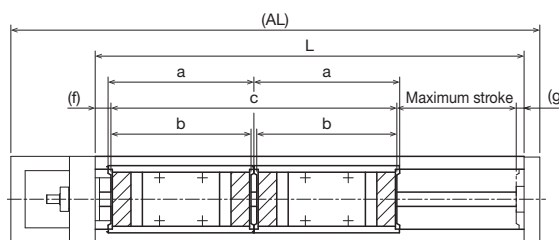

Block Type B/D

Unit: mm

Block type	Overall length AL	Outer rail length L	Stroke ¹	Maximum stroke ¹	a, b	c	f	g				
A	440.5	340	160	178.5	140	140	12.5	9				
	540.5	440	260	278.5								
	640.5	540	360	378.5								
	740.5	640	460	478.5								
	840.5	740	560	578.5								
	940.5	840	660	678.5								
	1,040.5	940	760	778.5								
B	540.5	440	120	138.5	140	280	12.5	9				
	640.5	540	220	238.5								
	740.5	640	320	338.5								
	840.5	740	420	438.5								
	940.5	840	520	538.5								
	1,040.5	940	620	638.5								
C	440.5	340	190	211.5	107	107	12.5	9				
	540.5	440	290	311.5								
	640.5	540	390	411.5								
	740.5	640	490	511.5								
	840.5	740	590	611.5								
	940.5	840	690	711.5								
	1,040.5	940	790	811.5								
D	440.5	340	85	104.5	107	214	12.5	9				
	540.5	440	185	204.5								
	640.5	540	285	304.5								
	740.5	640	385	404.5								
	840.5	740	485	504.5								
	940.5	840	585	604.5								
	1,040.5	940	685	704.5								

¹ The value for B/D block types is with 2 blocks attached.

Dimensions with QZ Lubricator

QZA (With Cover)
Block Type: A/C

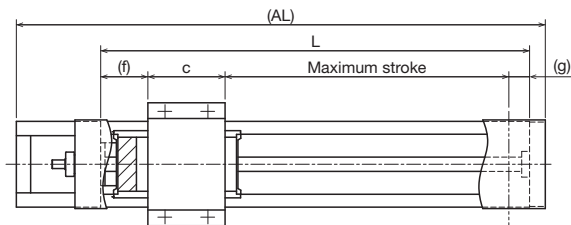

Block Type A/C

QZA (Without Cover)
Block Type: A/C

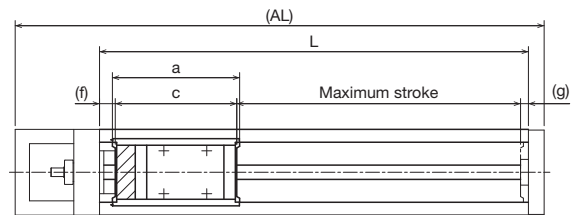

Block Type A/C

QZA (With Cover)

Unit: mm

Block type	Overall length AL	Outer rail length L	Stroke	Maximum stroke	c	f	g
A	440.5	340	175	193.5	81	42	23.5
	540.5	440	275	293.5			
	640.5	540	375	393.5			
	740.5	640	475	493.5			
	840.5	740	575	593.5			
	940.5	840	675	693.5			
C	1,040.5	940	775	793.5	48	42	23.5
	440.5	340	205	226.5			
	540.5	440	305	326.5			
	640.5	540	405	426.5			
	740.5	640	505	526.5			
	840.5	740	605	626.5			
940.5	840	705	726.5				
1,040.5	940	805	826.5				

Note 1: B/D block types cannot be selected for QZA.

QZA (Without Cover)

Unit: mm

Block type	Overall length AL	Outer rail length L	Stroke	Maximum stroke	a	c	f	g
A	440.5	340	175	193.5	125	125	12.5	9
	540.5	440	275	293.5				
	640.5	540	375	393.5				
	740.5	640	475	493.5				
	840.5	740	575	593.5				
	940.5	840	675	693.5				
C	1,040.5	940	775	793.5	92	92	12.5	9
	440.5	340	205	226.5				
	540.5	440	305	326.5				
	640.5	540	405	426.5				
	740.5	640	505	526.5				
	840.5	740	605	626.5				
940.5	840	705	726.5					
1,040.5	940	805	826.5					

Note 2: B/D block types cannot be selected for QZA.

Options

Dimensions with QZ Lubricator

QZB (With Cover)
Block Type: A/C

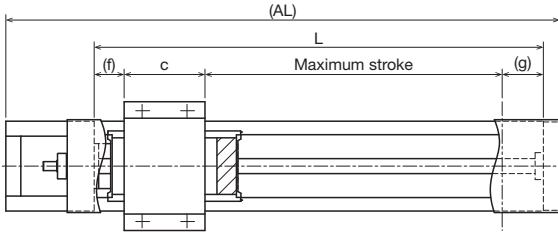

Block Type A/C

QZB (Without Cover)
Block Type: A/C

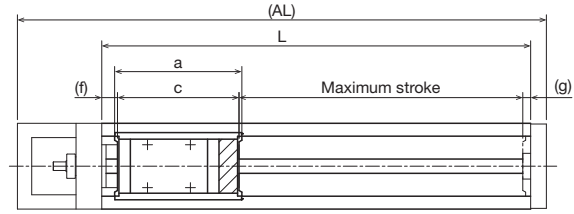

Block Type A/C

QZB (With Cover)

Unit: mm

Block type	Overall length AL	Outer rail length L	Stroke	Maximum stroke	c	f	g
A	440.5	340	175	193.5	81	27	38.5
	540.5	440	275	293.5			
	640.5	540	375	393.5			
	740.5	640	475	493.5			
	840.5	740	575	593.5			
	940.5	840	675	693.5			
	1,040.5	940	775	793.5			
C	440.5	340	205	226.5	48	27	38.5
	540.5	440	305	326.5			
	640.5	540	405	426.5			
	740.5	640	505	526.5			
	840.5	740	605	626.5			
	940.5	840	705	726.5			
	1,040.5	940	805	826.5			

Note 1: B/D block types cannot be selected for QZB.

QZB (Without Cover)

Unit: mm

Block type	Overall length AL	Outer rail length L	Stroke	Maximum stroke	a	c	f	g
A	440.5	340	175	193.5	125	125	12.5	9
	540.5	440	275	293.5				
	640.5	540	375	393.5				
	740.5	640	475	493.5				
	840.5	740	575	593.5				
	940.5	840	675	693.5				
	1,040.5	940	775	793.5				
C	440.5	340	205	226.5	92	92	12.5	9
	540.5	440	305	326.5				
	640.5	540	405	426.5				
	740.5	640	505	526.5				
	840.5	740	605	626.5				
	940.5	840	705	726.5				
	1,040.5	940	805	826.5				

Note 2: B/D block types cannot be selected for QZB.

Dimensions with QZ Lubricator

QZAD (With Cover)

Block Type: B/D

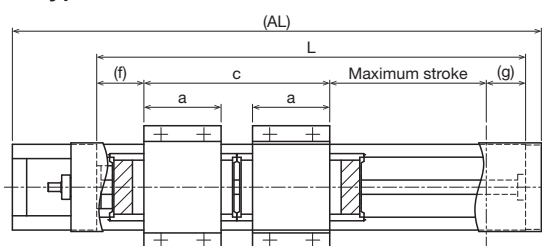

Block Type B/D

QZAD (Without Cover)

Block Type: B/D

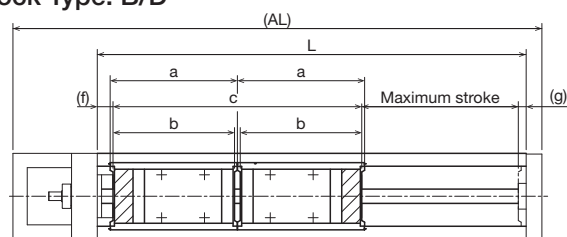

Block Type B/D

QZAD (With Cover)

Unit: mm

Block type	Overall length AL	Outer rail length L	Stroke ¹	Maximum stroke ¹	a	c	f	g
B	540.5	440	150	168.5	81	191	42	38.5
	640.5	540	250	268.5				
	740.5	640	350	368.5				
	840.5	740	450	468.5				
	940.5	840	550	568.5				
	1,040.5	940	650	668.5				
D	440.5	340	115	134.5	48	125	42	38.5
	540.5	440	215	234.5				
	640.5	540	315	334.5				
	740.5	640	415	434.5				
	840.5	740	515	534.5				
	940.5	840	615	634.5				
1,040.5	940	715	734.5					

¹ The value for B/D block types is with 2 blocks attached.

Note 1: A/C block types cannot be selected for QZAD.

QZAD (Without Cover)

Unit: mm

Block type	Overall length AL	Outer rail length L	Stroke ²	Maximum stroke ²	a, b	c	f	g
B	540.5	440	150	168.5	125	250	12.5	9
	640.5	540	250	268.5				
	740.5	640	350	368.5				
	840.5	740	450	468.5				
	940.5	840	550	568.5				
	1,040.5	940	650	668.5				
D	440.5	340	115	134.5	92	184	12.5	9
	540.5	440	215	234.5				
	640.5	540	315	334.5				
	740.5	640	415	434.5				
	840.5	740	515	534.5				
	940.5	840	615	634.5				
1,040.5	940	715	734.5					

² The value for B/D block types is with 2 blocks attached.

Note 2: A/C block types cannot be selected for QZAD.

SKR55 A/B

Direct motor coupling	Motor wrap	Width 100 mm	Height 55 mm	Max. stroke 1,200 mm
-----------------------	------------	--------------	--------------	----------------------

Model Number Coding

Model	Ball screw lead	Block type	Stroke	Accuracy grade	With/without motor	Cover	Sensors	Housing A/ Intermediate flange
①	②	③	④	⑤	⑥	⑦	⑧	⑨
SKR55	20	A	0800	P	0	1	2	A0
SKR55	20: 20 mm 30: 30 mm 40: 40 mm	A: x1 B: x2	0680: 680 mm to 1200: 1,200 mm	No symbol: Normal grade H: High accuracy grade P: Precision grade	With direct coupling 0: Direct coupling (without motor) 1: Direct coupling (THK will purchase and mount the motor you specify) With motor wrap R1: Non-standard side wrap (without motor) R2: Standard side wrap (without motor) R3: Bottom side wrap (without motor) R4: Non-standard side wrap (THK will purchase and mount the motor you specify) R5: Standard side wrap (THK will purchase and mount the motor you specify) R6: Bottom side wrap (THK will purchase and mount the motor you specify)	0: Without cover 1: With cover 2: With bellows	0 1 2 6 7 B E H L J M	With direct coupling A0 AZ A5 A6 20 With motor wrap WV-14M WZ-16M WZ-19M W5-19M
			When selecting 2: With bellows for ⑦ Cover, specify the stroke with bellows. → p. 109 to p. 110			When selecting "0": A coupling is not provided. Indicate when placing an order if a coupling is required.		
			When selecting "1," "R4," "R5," or "R6": The specified motor will be installed. Indicate the motor cable direction separately. Select ⑨ Intermediate flange to match the specified motor.			Sensor details → p. 91 With direct coupling → p. 93 With motor wrap → p. 95		

③ Block Type

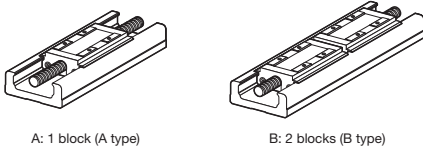

⑥ Motor Mounting Method

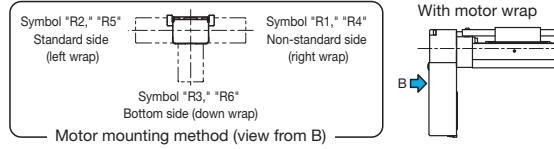

Selection Materials

Basic Specifications

LM Guide	Basic dynamic load rating C (N)		55,400		
	Basic static load rating C ₀ (N)		62,500		
	Radial clearance (mm)	Normal grade/High accuracy grade (H)	-0.007 to 0		
		Precision grade (P)	-0.019 to -0.007		
	Geometric moment of inertia	I _x ¹ (mm ⁴)	2.07×10 ⁶		
I _y ² (mm ⁴)		2.09×10 ⁶			
Mass (kg/m)		13.2			
Ball screw lead (mm)		20	30	40	
Ball screw	Basic dynamic load rating Ca (N)	Normal grade/High accuracy grade (H)	10,900	7,000	6,800
		Precision grade (P)			
	Basic static load rating C _{0a} (N)	Normal grade/High accuracy grade (H)	17,600	11,500	9,900
		Precision grade (P)			
	Screw shaft diameter (mm)		Ø20		
	Thread minor diameter (mm)		Ø17.1		
	Ball center-to-center diameter (mm)		Ø20.75		
Permissible rotational speed ³ (min ⁻¹)	Normal grade/High accuracy grade (H)	5,000	4,500		
	Precision grade (P)				
Bearing (Fixed side)	Axial direction	Basic dynamic load rating Ca (N)	7,600		
		Static permissible load P _{0a} (N)	3,990		
Permissible input torque (N·m)	Direct coupling		8.5		
	Motor wrap		6.4		
Static permissible moment ^{4,5} (N·m)		M _A : 923 (5,125), M _B : 923 (5,125), M _C : 2,276 (4,552)			
Running life ⁶ (km)		10,000			
Standard grease/Grease nipple used		THK AFB-LF Grease/A-M6F			

¹ I_x is the geometric moment of inertia about the X axis.
² I_y is the geometric moment of inertia about the Y axis.
³ The permissible rotational speed may decrease as the stroke becomes longer.
⁴ The value in parentheses is with 2 blocks (B type) attached.
⁵ See p. 116 for the values if "1" or "2" is selected for item ⑦ in the Model Number Coding.
⁶ Calculated under the following conditions.
 Stroke: 1,000 mm (A type), 880 mm (B type) / Speed: 1,000 mm/s (for 20 mm lead), 1,500 mm/s (for 30 mm lead), 2,000 mm/s (for 40 mm lead) / Load mass: Maximum load capacity (p. 9) / Acceleration/deceleration: As when set to maximum load capacity (p. 9) / Center of gravity: Center of the table's upper surface.
 Notes: 1. Customized products can also be made to handle special environments or large axial loads (25% or more of the basic dynamic load rating Ca). Consult with THK.
 2. LM Guide load rating is the load rating per block.

Accuracy

Accuracy grade	Item	Stroke ⁷				
		800	900	1,000	1,100	1,200
		Normal grade (no symbol)				
		Positioning repeatability (mm)				
		±0.01				
Positioning accuracy (mm)					Not specified	
Running parallelism (vertical direction) (mm)					Not specified	
Backlash (mm)					0.05	
Starting torque (N·cm)					12	
Accuracy grade	Item	Stroke ⁷				
		800	900	1,000	1,100	1,200
		High accuracy grade (H)				
		Positioning repeatability (mm)				
		±0.005				
Positioning accuracy (mm)					0.18 0.25	
Running parallelism (vertical direction) (mm)					0.05	
Backlash (mm)					0.05	
Starting torque (N·cm)					12	
Accuracy grade	Item	Stroke ⁷				
		800	900	1,000		
		Precision grade (P)				
		Positioning repeatability (mm)				
		±0.005				
Positioning accuracy (mm)					0.035 0.04	
Running parallelism (vertical direction) (mm)					0.025 0.03	
Backlash (mm)					0.003	
Starting torque (N·cm)					17 20	

⁷ Stroke with 1 block (A type).
 Notes: 3. Precision evaluation in accordance with THK standards.
 4. Measured using a motor for inspection. With motor wrap specifications, measurements are not made in the completed motor wrap state.
 5. The starting torque represents the value when containing THK AFB-LF Grease.
 6. The starting torque may exceed standards if using vacuum grease, clean room grease, or other high-viscosity greases, so care should be taken when selecting a motor.
 7. Contact THK for accuracy higher than the standard stroke.

Geometric Moment of Inertia

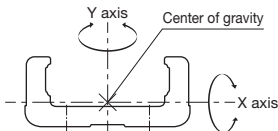

Static Permissible Moment

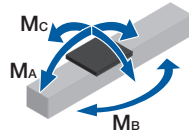

With Cover
Direct Motor Coupling

Dimensions

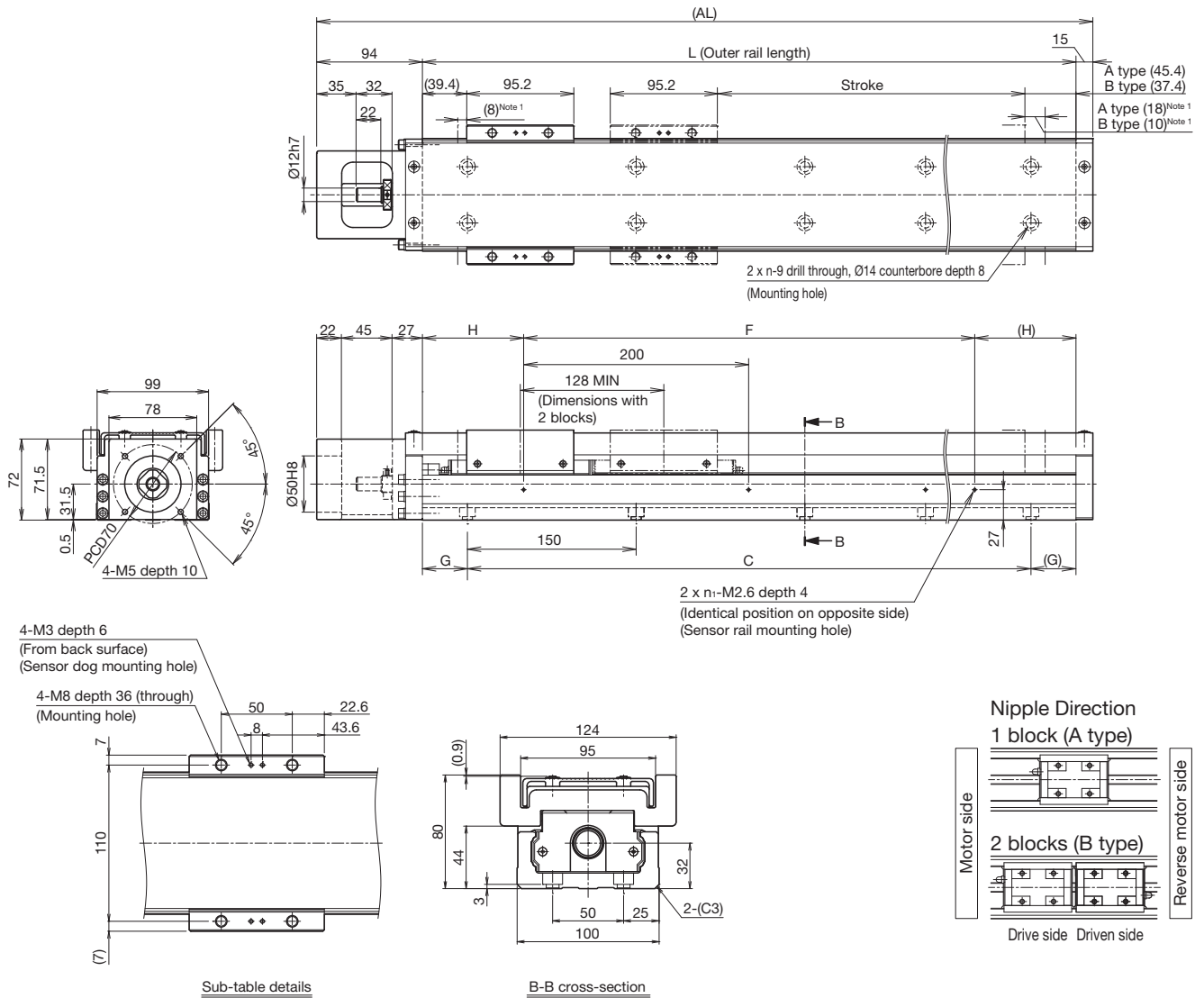

¹ Dimensions from the mechanical stopper to the stroke start position.

Stroke (mm) (Stroke between mechanical stoppers)	A type	800 (826)	900 (926)	1,000 (1,026)	1,100 (1,126)	1,200 (1,226)	
	B type ²	680 (698)	780 (798)	880 (898)	980 (998)	1,080 (1,098)	
Maximum speed ³ (mm/s)	Ball screw lead: 20 mm	Normal grade/High accuracy grade	1,100	880	730	610	520
		Precision grade	-	-	-	-	-
	Ball screw lead: 30 mm	Normal grade/High accuracy grade	1,650	1,330	1,100	920	780
		Precision grade	-	-	-	-	-
Ball screw lead: 40 mm	Normal grade/High accuracy grade	2,160	1,750	1,440	1,210	1,030	
	Precision grade	-	-	-	-	-	
Dimensions (mm)	AL	1,089	1,189	1,289	1,389	1,489	
	L	980	1,080	1,180	1,280	1,380	
	C	900	1,050	1,050	1,200	1,350	
	G	40	15	65	40	15	
	F	800	1,000	1,000	1,200	1,200	
	H	90	40	90	40	90	
No. of mounting holes	n	7	8	8	9	10	
	n ₁	5	6	6	7	7	
Mass ⁴ (kg)		23.8	25.7	27.6	29.5	31.4	

² The value with 2 blocks (B type) attached.

³ The maximum speed is restricted by the actuator's permissible speed.

⁴ The mass with 2 blocks (B type) has 3.8 kg added.

Without Cover
Direct Motor Coupling

Dimensions

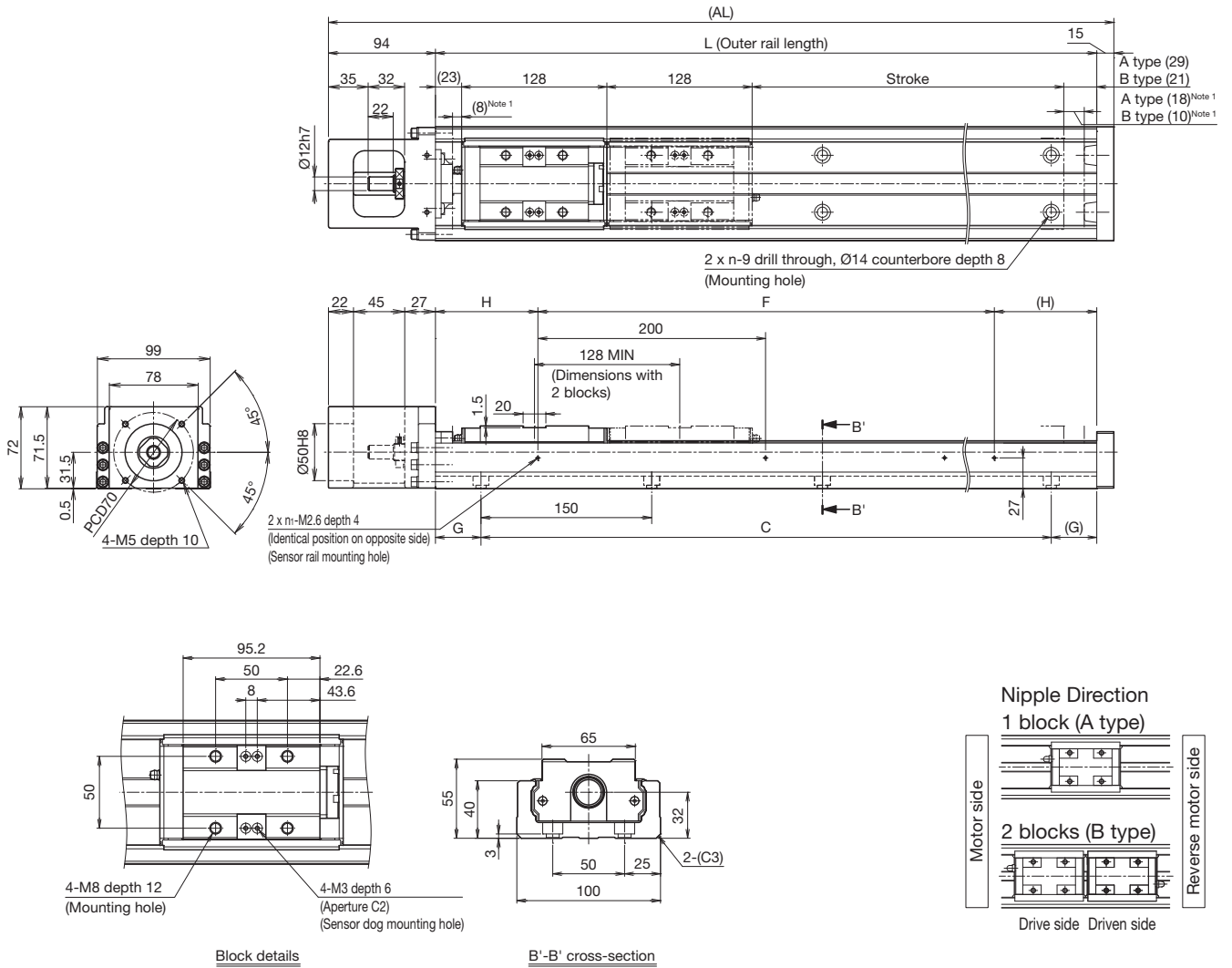

¹ Dimensions from the mechanical stopper to the stroke start position.

Stroke (mm) (Stroke between mechanical stoppers)	A type	800 (826)	900 (926)	1,000 (1,026)	1,100 (1,126)	1,200 (1,226)	
	B type ²	680 (698)	780 (798)	880 (898)	980 (998)	1,080 (1,098)	
Maximum speed ³ (mm/s)	Ball screw lead: 20 mm	Normal grade/High accuracy grade	1,100	880	730	610	520
		Precision grade	-	-	-	-	-
	Ball screw lead: 30 mm	Normal grade/High accuracy grade	1,650	1,330	1,100	920	780
		Precision grade	-	-	-	-	-
Ball screw lead: 40 mm	Normal grade/High accuracy grade	2,160	1,750	1,440	1,210	1,030	
	Precision grade	-	-	-	-	-	
Dimensions (mm)	AL	1,089	1,189	1,289	1,389	1,489	
	L	980	1,080	1,180	1,280	1,380	
	C	900	1,050	1,050	1,200	1,350	
	G	40	15	65	40	15	
	F	800	1,000	1,000	1,200	1,200	
	H	90	40	90	40	90	
No. of mounting holes	n	7	8	8	9	10	
	n ₁	5	6	6	7	7	
Mass ⁴ (kg)		20.9	22.6	24.4	26.2	27.9	

² The value with 2 blocks (B type) attached.

³ The maximum speed is restricted by the actuator's permissible speed.

⁴ The mass with 2 blocks (B type) has 1.9 kg added.

With Cover Motor Flange Size 60x60
Motor Wrap

Dimensions

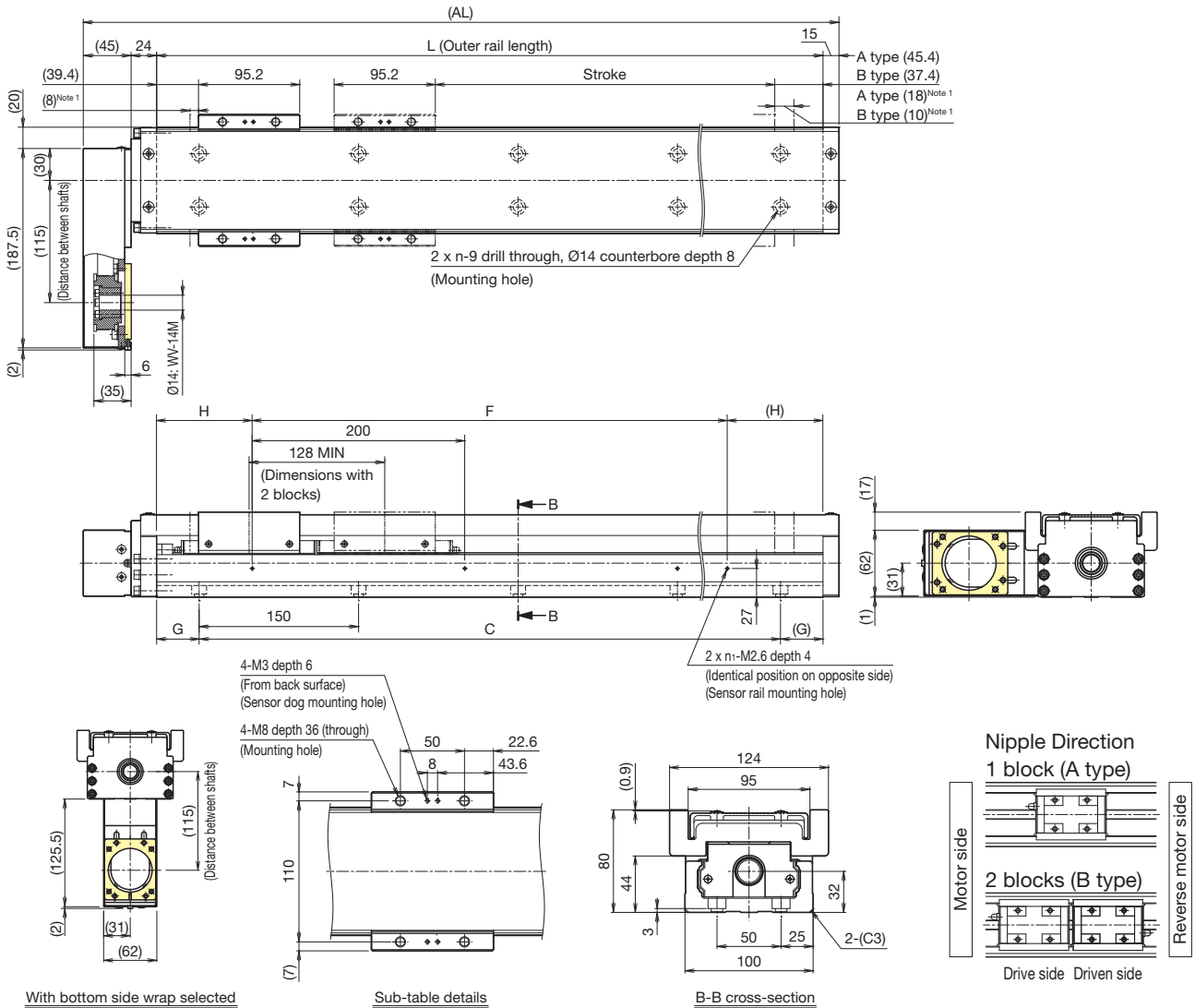

¹ Dimensions from the mechanical stopper to the stroke start position.

Stroke (mm) (Stroke between mechanical stoppers)	A type	800 (826)	900 (926)	1,000 (1,026)	1,100 (1,126)	1,200 (1,226)	
	B type ²	680 (698)	780 (798)	880 (898)	980 (998)	1,080 (1,098)	
Maximum speed ³ (mm/s)	Ball screw lead: 20 mm	Normal grade/High accuracy grade Precision grade	1,100	880	730	610	520
	Ball screw lead: 30 mm	Normal grade/High accuracy grade Precision grade	1,650	1,330	1,100	920	780
	Ball screw lead: 40 mm	Normal grade/High accuracy grade Precision grade	2,160	1,750	1,440	1,210	1,030
Dimensions (mm)	AL	1,064	1,164	1,264	1,364	1,464	
	L	980	1,080	1,180	1,280	1,380	
	C	900	1,050	1,200	1,200	1,350	
	G	40	15	65	40	15	
	F	800	1,000	1,000	1,200	1,200	
No. of mounting holes	n	7	8	8	9	10	
	n ₁	5	6	6	7	7	
Mass ⁴ (kg)		24.8	26.7	28.6	30.5	32.4	

² The value with 2 blocks (B type) attached.

³ The maximum speed is restricted by the actuator's permissible speed.

⁴ The mass with 2 blocks (B type) has 3.8 kg added.

Without Cover Motor Flange Size 60x60
Motor Wrap

Dimensions

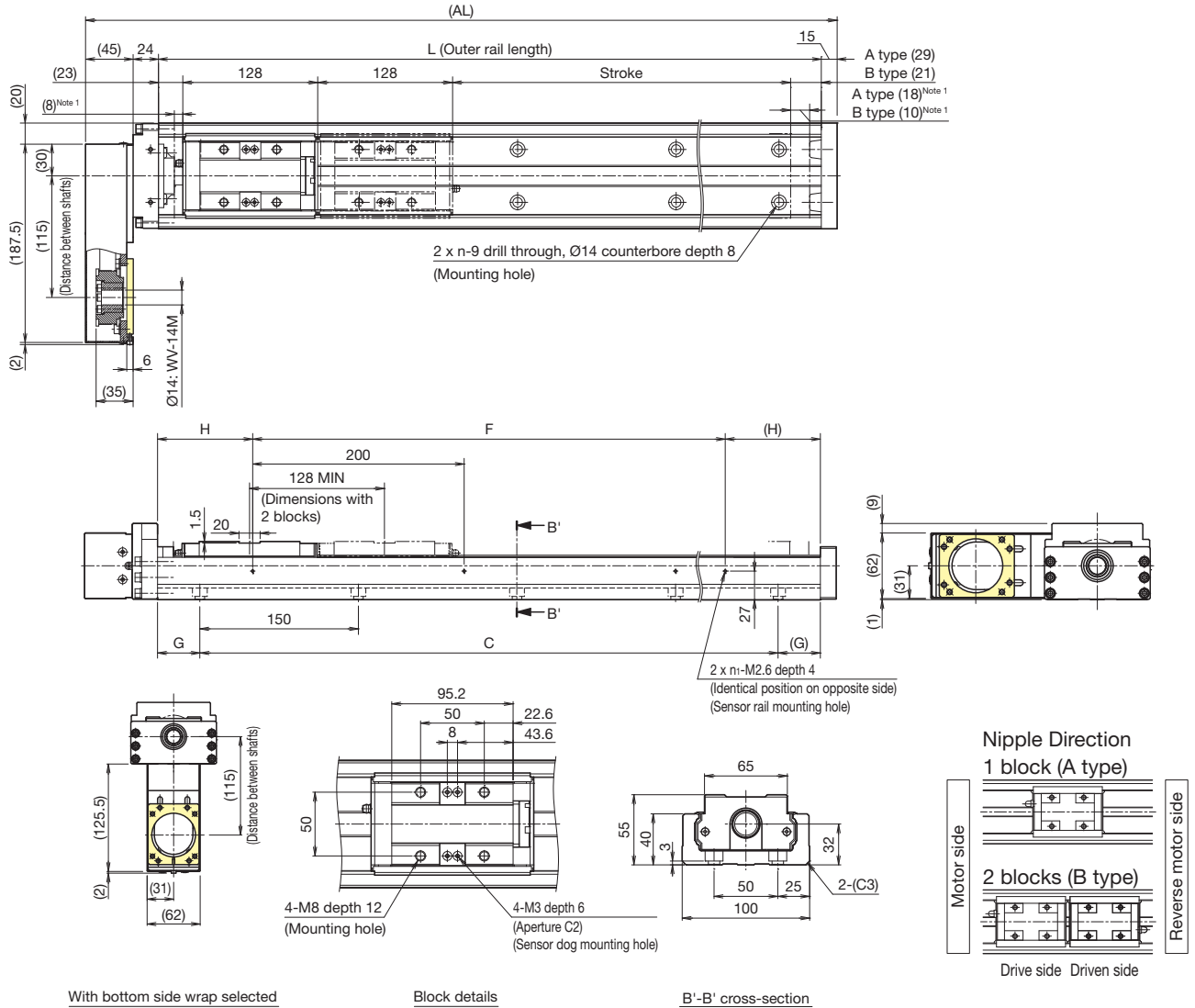

With bottom side wrap selected

Block details

B'-B' cross-section

¹ Dimensions from the mechanical stopper to the stroke start position.

Stroke (mm) (Stroke between mechanical stoppers)	A type		800 (826)	900 (926)	1,000 (1,026)	1,100 (1,126)	1,200 (1,226)
	B type ²		680 (698)	780 (798)	880 (898)	980 (998)	1,080 (1,098)
Maximum speed ³ (mm/s)	Ball screw lead: 20 mm	Normal grade/High accuracy grade	1,100	880	730	610	520
		Precision grade	-	-	-	-	-
	Ball screw lead: 30 mm	Normal grade/High accuracy grade	1,650	1,330	1,100	920	780
		Precision grade	-	-	-	-	-
Ball screw lead: 40 mm	Normal grade/High accuracy grade	2,160	1,750	1,440	1,210	1,030	
	Precision grade	-	-	-	-	-	
Dimensions (mm)	AL		1,064	1,164	1,264	1,364	1,464
	L		980	1,080	1,180	1,280	1,380
	C		900	1,050	1,050	1,200	1,350
	G		40	15	65	40	15
	F		800	1,000	1,000	1,200	1,200
	H		90	40	90	40	90
No. of mounting holes	n		7	8	8	9	10
	n ₁		5	6	6	7	7
Mass ⁴ (kg)			21.8	23.6	25.3	27.1	28.9

² The value with 2 blocks (B type) attached.

³ The maximum speed is restricted by the actuator's permissible speed.

⁴ The mass with 2 blocks (B type) has 1.9 kg added.

With Cover Motor Flange Size 80x80
Motor Wrap

Dimensions

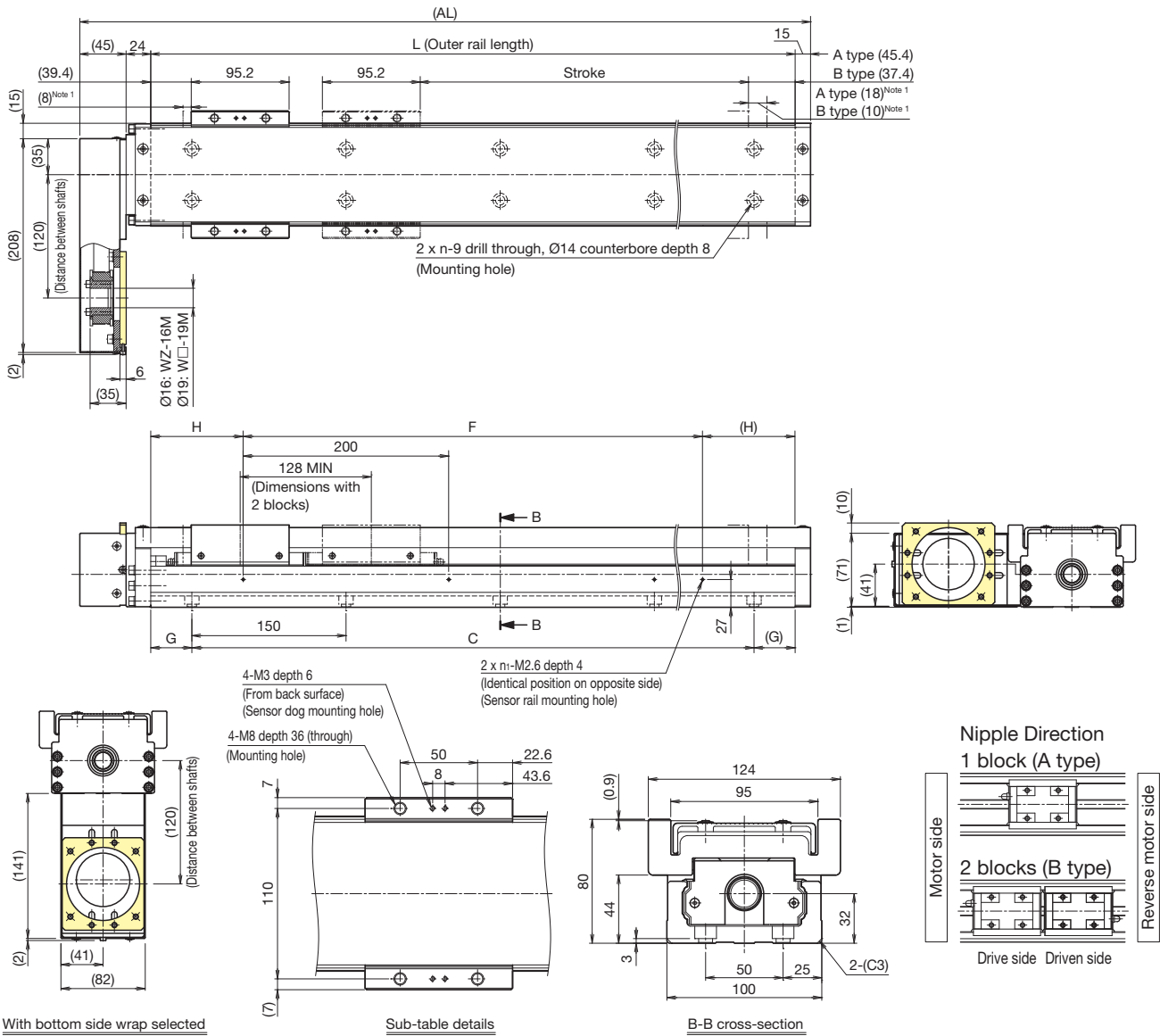

¹ Dimensions from the mechanical stopper to the stroke start position.

Stroke (mm) (Stroke between mechanical stoppers)	A type	800 (826)	900 (926)	1,000 (1,026)	1,100 (1,126)	1,200 (1,226)	
	B type ²	680 (698)	780 (798)	880 (898)	980 (998)	1,080 (1,098)	
Maximum speed ³ (mm/s)	Ball screw lead: 20 mm	Normal grade/High accuracy grade	1,100	880	730	610	520
		Precision grade	-	-	-	-	-
	Ball screw lead: 30 mm	Normal grade/High accuracy grade	1,650	1,330	1,100	920	780
	Precision grade	-	-	-	-	-	
Ball screw lead: 40 mm	Normal grade/High accuracy grade	2,160	1,750	1,440	1,210	1,030	
	Precision grade	-	-	-	-	-	
Dimensions (mm)	AL	1,064	1,164	1,264	1,364	1,464	
	L	980	1,080	1,180	1,280	1,380	
	C	900	1,050	1,200	1,200	1,350	
	G	40	15	65	40	15	
	F	800	1,000	1,000	1,200	1,200	
	H	90	40	90	40	90	
No. of mounting holes	n	7	8	8	9	10	
	n ₁	5	6	6	7	7	
Mass ⁴ (kg)		24.8	26.7	28.6	30.5	32.4	

² The value with 2 blocks (B type) attached.
³ The maximum speed is restricted by the actuator's permissible speed.
⁴ The mass with 2 blocks (B type) has 3.8 kg added.

Without Cover Motor Flange Size 80x80
Motor Wrap

Dimensions

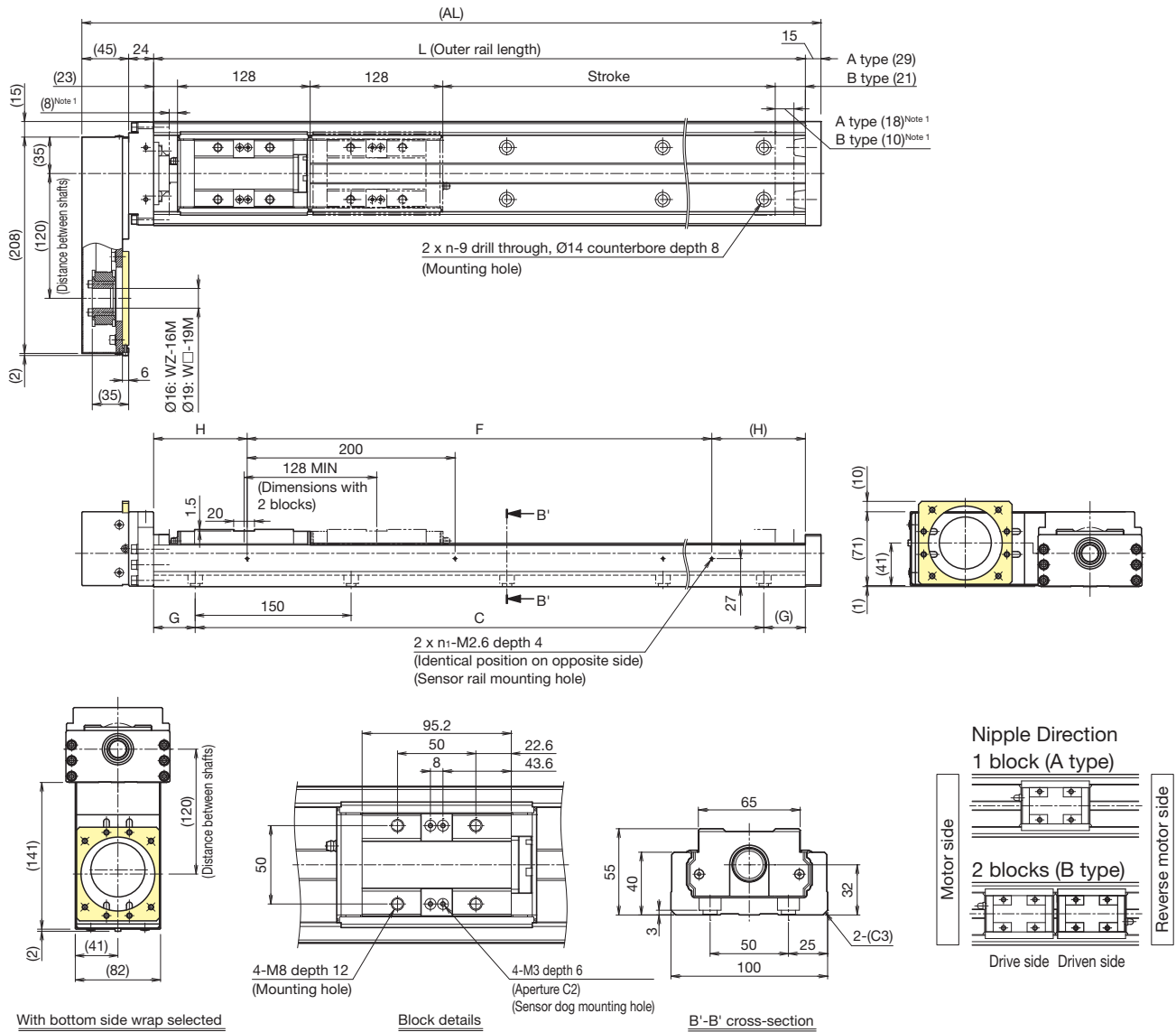

¹ Dimensions from the mechanical stopper to the stroke start position.

Stroke (mm) (Stroke between mechanical stoppers)	A type		800 (826)	900 (926)	1,000 (1,026)	1,100 (1,126)	1,200 (1,226)
	B type ²		680 (698)	780 (798)	880 (898)	980 (998)	1,080 (1,098)
Maximum speed ³ (mm/s)	Ball screw lead: 20 mm	Normal grade/High accuracy grade	1,100	880	730	610	520
		Precision grade	-	-	-	-	-
	Ball screw lead: 30 mm	Normal grade/High accuracy grade	1,650	1,330	1,100	920	780
		Precision grade	-	-	-	-	-
Ball screw lead: 40 mm	Normal grade/High accuracy grade	2,160	1,750	1,440	1,210	1,030	
	Precision grade	-	-	-	-	-	
Dimensions (mm)	AL		1,064	1,164	1,264	1,364	1,464
	L		980	1,080	1,180	1,280	1,380
	C		900	1,050	1,050	1,200	1,350
	G		40	15	65	40	15
	F		800	1,000	1,000	1,200	1,200
	H		90	40	90	40	90
No. of mounting holes	n		7	8	8	9	10
	n ₁		5	6	6	7	7
Mass ⁴ (kg)			21.8	23.6	25.3	27.1	28.9

² The value with 2 blocks (B type) attached.

³ The maximum speed is restricted by the actuator's permissible speed.

⁴ The mass with 2 blocks (B type) has 1.9 kg added.

Options

Sensors

Optional photo sensors and proximity sensors are available. Sensor-equipped models also feature a dedicated sensor rail and sensor dog.

Sensors, sensor rails, and sensor dogs can be mounted on both sides when the stroke is less than 70 mm.

Mounting example

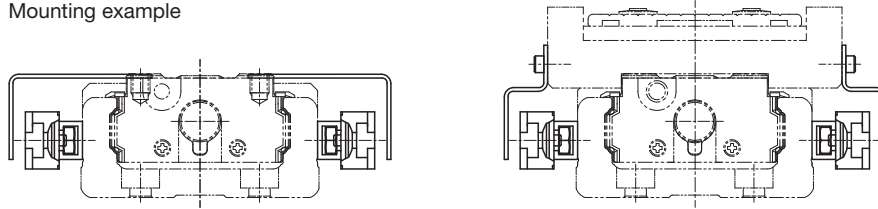

Symbol	Description	Model	Accessories
0	None	-	-
1	With sensor rail	-	Mounting screws, sensor rail (x1 or 2)
2	Photo sensor ¹ (x3)	EE-SX671 (OMRON Corporation)	Mounting screws, nuts, sensor dog (x1 or 2), sensor rail (x1 or 2), mounting plates (x3), connectors (EE-1001 x3)
6	Photo sensor ¹ (x3)	EE-SX674 (OMRON Corporation)	Mounting screws, nuts, sensor dog (x1 or 2), sensor rail (x1 or 2), mounting plates (x3), connectors (EE-1001 x3)
7	Proximity sensor N.O. contact ² (x3)	APM-D3A1-001 (Azbil Corporation)	Mounting screws, nuts, sensor dog (x1 or 2), sensor rail (x1 or 2)
B	Proximity sensor N.C. contact ³ (x3)	APM-D3B1-003 (Azbil Corporation)	Mounting screws, nuts, sensor dog (x1 or 2), sensor rail (x1 or 2)
E	Proximity sensor N.O. contact ² (x1) N.C. contact ³ (x2)	APM-D3A1-001 (Azbil Corporation) APM-D3B1-003 (Azbil Corporation)	Mounting screws, nuts, sensor dog (x1 or 2), sensor rail (x1 or 2)
H	Proximity sensor N.O. contact ² (x3)	GX-F12A (Panasonic Industry Co., Ltd.)	Mounting screws, nuts, sensor dog (x1 or 2), sensor rail (x1 or 2)
L	Proximity sensor N.C. contact ³ (x3)	GX-F12B (Panasonic Industry Co., Ltd.)	Mounting screws, nuts, sensor dog (x1 or 2), sensor rail (x1 or 2)
J	Proximity sensor N.O. contact ² (x1) N.C. contact ³ (x2)	GX-F12A (Panasonic Industry Co., Ltd.) GX-F12B (Panasonic Industry Co., Ltd.)	Mounting screws, nuts, sensor dog (x1 or 2), sensor rail (x1 or 2)
M	Proximity sensor N.O. contact ² (x1) (PNP output) N.C. contact ³ (x2) (PNP output)	GX-F12A-P (Panasonic Industry Co., Ltd.) GX-F12B-P (Panasonic Industry Co., Ltd.)	Mounting screws, nuts, sensor dog (x1 or 2), sensor rail (x1 or 2)

¹ The photo sensors can be switched between ON when lit and ON when unlit.

² N.O. contact: Normally open contact point

³ N.C. contact: Normally closed contact point

Notes: 1. If proximity sensors are close to one another, they may not function properly. If that happens, please prepare a type with a different frequency.

2. Mounting of sensors other than those in the table above is possible. Contact THK for details.

Sensor Rail Mounting Dimensions

Mounting only a sensor rail is also possible.

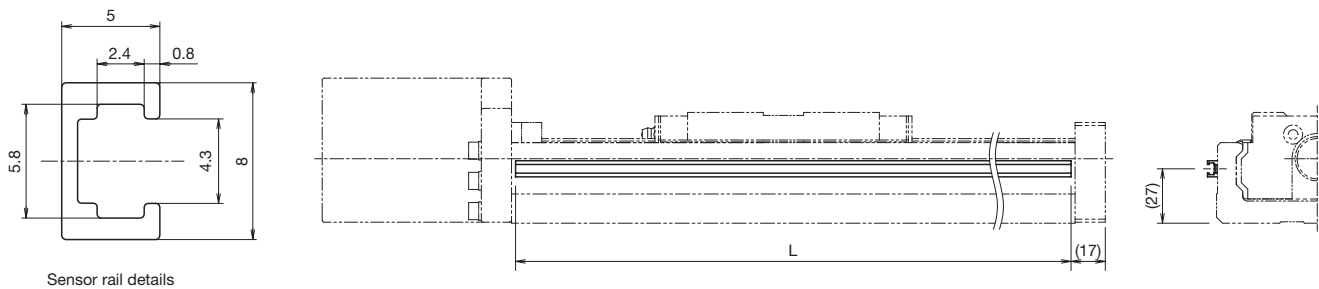

Sensor rail details

Stroke ⁴ (mm)	Outer rail length (mm)	L (mm)
800	980	976
900	1,080	1,076
1,000	1,180	1,176
1,100	1,280	1,276
1,200	1,380	1,376

⁴ Stroke with 1 block (A type).

Photo Sensor Mounting Dimensions

Connector: EE-1001 (OMRON Corporation) x3 included.
To be mounted by the customer.

Without cover

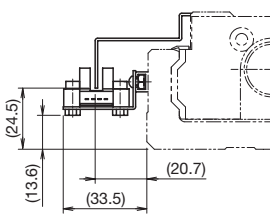

With cover

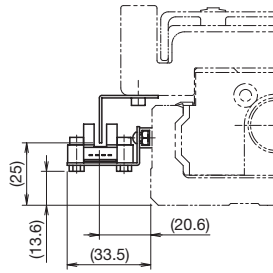

Symbol	Model	Manufacturer
2	EE-SX671	OMRON Corporation

Sensor dog width: 20 mm

Without cover

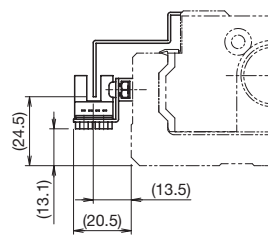

With cover

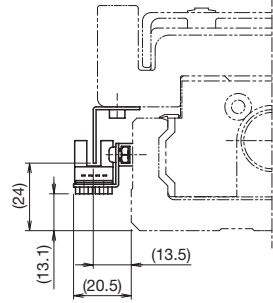

Symbol	Model	Manufacturer
6	EE-SX674	OMRON Corporation

Sensor dog width: 20 mm

Proximity Sensor Mounting Dimensions

Without cover

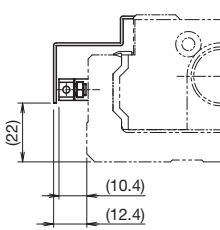

With cover

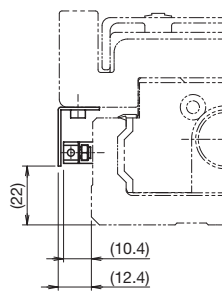

Symbol	Model	Manufacturer
7, B, E	APM-D3A1-001	Azbil Corporation
	APM-D3B1-003	

Sensor dog width: 20 mm

Without cover

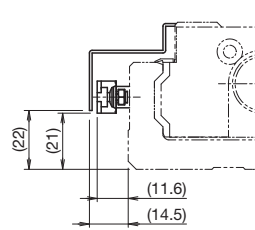

With cover

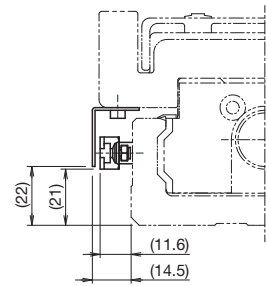

Symbol	Model	Manufacturer
H, L, J	GX-F12A	Panasonic Industry Co., Ltd.
	GX-F12B	
M	GX-F12A-P	
	GX-F12B-P	

Sensor dog width: 20 mm

Options

Intermediate Flange (Direct Coupling)

Several types of intermediate flanges for mounting motors are available.

When selecting "0" or "1" for Model Number Coding ⑥ With/without motor, specify an intermediate flange that matches the motor used.

Compatibility Table: Motors Used, Intermediate Flanges, and Couplings

Motor type	Manufacturer	Motor model		Motor rated output (W)	Flange size	Housing A/ Intermediate flange	Compatible coupling models			
							MIKI PULLEY CO., LTD.	Nabeya Bi-tech Kaisha (NBK)		
AC servo motor	YASKAWA Electric Corporation	Σ-V	SGMJV-02	200	60×60	A0	SFC-030DA2-12B-14B	XGT2-27C-12-14		
			SGMAV-02							
			SGMJV-04	400		A0	SFC-035DA2-12B-14B	XGT2-30C-12-14		
			SGMAV-04							
			SGMJV-06	600		A0	SFC-035DA2-12B-14B	XGT2-34C-12-14		
			SGMJV-08							
		SGMAV-08	750	80×80	SFC-040DA2-12B-19B	XGT2-39C-12-19				
		SGMAV-08								
		Σ-7	SGM7J-02	200	60×60	A0	SFC-030DA2-12B-14B	XGT2-27C-12-14		
			SGM7A-02							
			SGM7J-04	400		A0	SFC-035DA2-12B-14B	XGT2-30C-12-14		
			SGM7A-04							
			SGM7J-06	600		A0	SFC-035DA2-12B-14B	XGT2-34C-12-14		
			SGM7J-08							
		SGM7A-08	750	80×80	SFC-040DA2-12B-19B	XGT2-39C-12-19				
		SGM7A-08								
		Σ-X	SGMXJ-02	200	60×60	A0	SFC-030DA2-12B-14B	XGT2-27C-12-14		
			SGMXA-02							
	SGMXJ-04		400	A0		SFC-035DA2-12B-14B	XGT2-30C-12-14			
	SGMXA-04									
	SGMXJ-06		600	A0		SFC-035DA2-12B-14B	XGT2-34C-12-14			
	SGMXA-06									
	SGMXJ-08		750	80×80		SFC-040DA2-12B-19B	XGT2-39C-12-19			
	SGMXA-08									
	Mitsubishi Electric Corporation	MELSERVO	J4	HG-KR23	200	60×60	A0	SFC-030DA2-12B-14B	XGT2-27C-12-14	
				HG-MR23						
				HG-KR43	400		A0	SFC-035DA2-12B-14B	XGT2-30C-12-14	
			HG-MR43							
			HG-KR73	750	80×80		AZ	SFC-040DA2-12B-19B	XGT2-39C-12-19	
			HG-MR73							
		J5	HK-KT23W	200	60×60	A0	SFC-030DA2-12B-14B	XGT2-27C-12-14		
			HK-KT43W	400	60×60	A0	SFC-035DA2-12B-14B	XGT2-30C-12-14		
			HK-KT7M3W	750	80×80	AZ	SFC-040DA2-12B-19B	XGT2-39C-12-19		
		JN	HF-KN23	200	60×60	A0	SFC-030DA2-12B-14B	XGT2-27C-12-14		
			HF-KN43	400			SFC-035DA2-12B-14B	XGT2-30C-12-14		
			HF-KN43	400			SFC-035DA2-12B-14B	XGT2-30C-12-14		
	TAMAGAWA SEIKI CO., LTD.	TBL-iii	TS4607	200	60×60	A0	SFC-030DA2-12B-14B	XGT2-27C-12-14		
			TS4609	400			SFC-035DA2-12B-14B	XGT2-30C-12-14		
			TS4614	750			80×80	AZ	SFC-040DA2-12B-19B	XGT2-39C-12-19
			TSM3202	200			60×60	A0	SFC-030DA2-12B-14B	XGT2-27C-12-14
			TSM3204	400					SFC-035DA2-12B-14B	XGT2-30C-12-14
		TBL-iiV	TSM3303	600	80×80	AZ	SFC-040DA2-12B-19B	XGT2-39C-12-19		
TSM3304			750							
TSM3304			750							
TSM3304			750							
TSM3304			750							
Panasonic Corporation	MINAS	A5	MSMD08	750	80×80	A5	SFC-040DA2-12B-19B	XGT2-39C-12-19		
			MSME08							
	A6	MSMF08	750	80×80	A5	SFC-040DA2-12B-19B	XGT2-39C-12-19			
		MHMF08								
KEYENCE CORPORATION	SV	SV-M020	200	60×60	A0	SFC-030DA2-12B-14B	XGT2-27C-12-14			
		SV-M040	400			SFC-035DA2-12B-14B	XGT2-30C-12-14			
		SV-M075	750			80×80	AZ	SFC-040DA2-12B-19B	XGT2-39C-12-19	
	SV2	SV2-M020	200	60×60	A0	SFC-030DA2-12B-14B	XGT2-27C-12-14			
		SV2-M040	400			SFC-035DA2-12B-14B	XGT2-30C-12-14			
		SV2-M075	750			80×80	AZ	SFC-040DA2-12B-19B	XGT2-39C-12-19	
SANYO DENKI CO., LTD.	SANMOTION R	R2□A06020	200	60×60	A0	SFC-030DA2-12B-14B	XGT2-27C-12-14			
		R2AA06040	400			SFC-035DA2-12B-14B	XGT2-30C-12-14			
		R2AA08075	750			80×80	AZ	SFC-040DA2-12B-16B	XGT2-39C-12-16	
OMRON Corporation	OMNUC G5	R88M-K75030	750	80×80	A5	SFC-040DA2-12B-19B	XGT2-39C-12-19			
		1S R88M-1M75030	750							

Motor type	Manufacturer	Motor model		Flange size	Housing A/ Intermediate flange	Compatible coupling models	
						MIKI PULLEY CO., LTD.	Nabeya Bi-tech Kaisha (NBK)
Stepper motor	ORIENTAL MOTOR CO., LTD.	α step		AZ9*, AR9*	85×85	A6	SFC-035DA2-12B-14B XGT2-34C-12-14
		5-phase	RK II	RKS59*	85×85	A6	SFC-035DA2-12B-14B XGT2-34C-12-14

Notes: 1. The table shows only a portion of the model numbers for motors. For details regarding model numbers, please see the catalog for each respective motor manufacturer.
 2. If the maximum torque for motors exceeds the permissible input torque (p. 83), please consider a safety measure to limit the torque.
 3. When installing a motor other than the motor model numbers listed above, contact THK.

Housing A

SKR55
A0

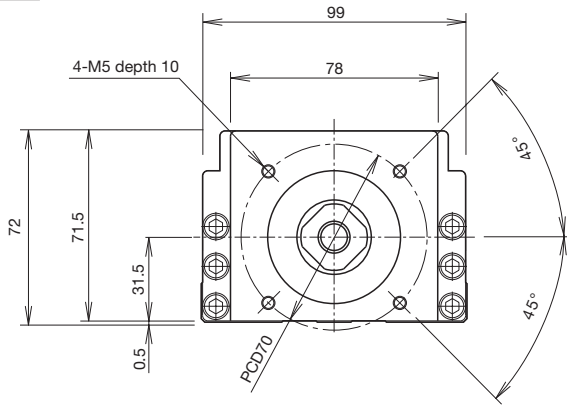

SKR**	Actuator model
●◇	●: Housing A ◇: Intermediate flange

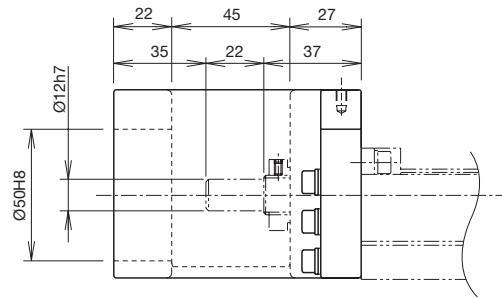

Intermediate Flange

SKR55
A5

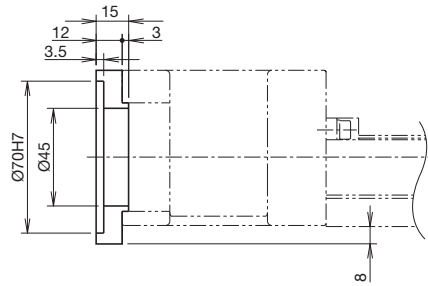
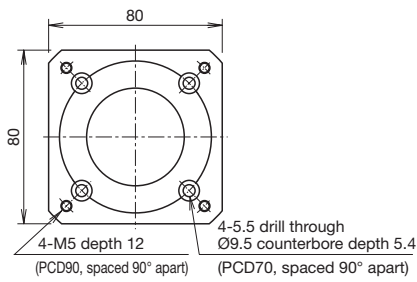

SKR55
AZ

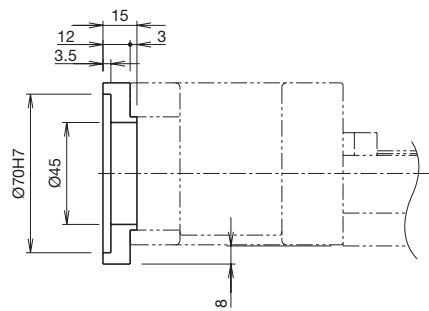
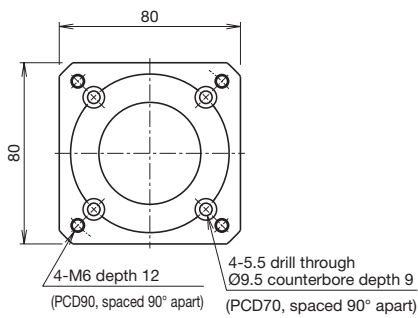

SKR55
A6

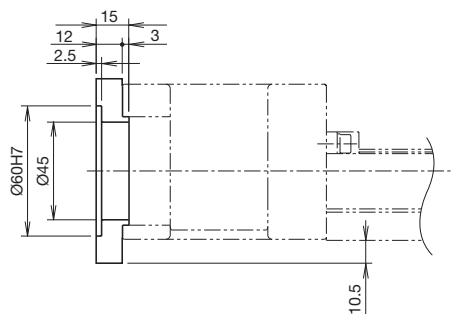
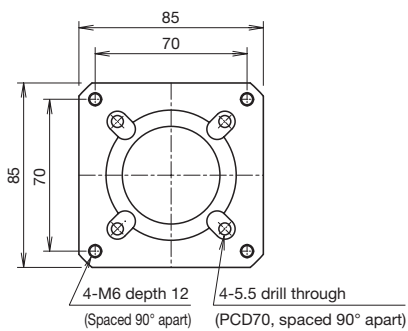

Options

Intermediate Flange (Motor Wrap)

Several types of intermediate flanges for mounting motors are available.

When selecting "R1," "R2," "R3," "R4," "R5," or "R6" for Model Number Coding ⑥ With/without motor, specify an intermediate flange that matches the motor used.

Symbol Coding

Motor wrap symbol ①	Intermediate flange ②	Motor shaft diameter (mm) ③	Motor shaft securing method ④
W	V	14	M
W	Refer to the Compatibility Table: Motors Used and Motor Wrap Symbols below.	Specify a motor shaft diameter. (Refer to the Compatibility Table: Motors Used and Motor Wrap Symbols below.)	M: Friction tightening tool

Motor Shaft Securing Method

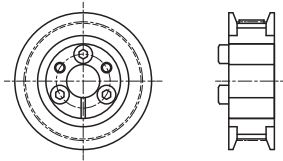

Friction tightening tool

Compatibility Table: Motors Used and Motor Wrap Symbols

Motor type	Manufacturer	Motor model	Motor rated output (W)	Flange size	Housing A/Intermediate flange					
AC servo motor	YASKAWA Electric Corporation	Σ-V	SGMJV-02	200	60×60	WV-14M				
			SGMAV-02	400						
			SGMJV-04							
			SGMAV-04							
			SGMJV-06				600			
			SGMAV-06							
		Σ-7	SGMJV-08		200	80×80	WZ-19M			
			SGMAV-08							
			SGM7J-02							
			SGM7A-02							
			SGM7J-04	400						
			SGM7A-04							
		Σ-X	SGM7J-06	200	80×80	WZ-19M				
			SGM7J-08							
			SGM7A-08							
			SGMXJ-02							
			SGMXA-02				400			
			SGMXJ-04							
	SGMXA-04	600								
	SGMXJ-06									
	SGMXA-06	750								
	SGMXJ-08									
	SGMXA-08	750	80×80	WZ-19M						
	Mitsubishi Electric Corporation	MELSERVO	J4	HG-MR23	200	60×60	WV-14M			
				HG-KR23						
				HG-MR43				400		
				HG-KR43						
				HG-MR73				750		
				HG-KR73						
		J5	HK-KT23W	200	60×60	WV-14M				
			HK-KT43W							
			HK-KT7M3W				750			
			HF-KN23							
			JN				HF-KN43	200	60×60	WV-14M
							HF-KN43			
	TAMAGAWA SEIKI CO., LTD.	TBL-III	TS4607	200	60×60	WV-14M				
			TS4609	400						
			TS4614	750						
			TSM3202	200			80×80	WZ-19M		
		TSM3204	400							
TSM3303		600								
TSM3304		750								
TBL-IV		TSM3202	200	60×60	WV-14M					
	TSM3204	400								
	TSM3303	600								
	TSM3304	750								
Panasonic Corporation	MINAS	A5	MMSD08	750	80×80	W5-19M				
			MSME08							
		A6	MSMF08							
			MHMF08							
KEYENCE CORPORATION	SV	SV-M020	200	60×60	WV-14M					
		SV-M040	400							
		SV-M075	750							
	SV2	SV2-M020	200	60×60	WV-14M					
		SV2-M040	400							
		SV2-M075	750							
SANYO DENKI CO., LTD.	SANMOTION R	R2□A06020	200	60×60	WV-14M					
		R2AA06040	400							
		R2AA08075	750							
		R2AA08075	750							
OMRON Corporation	OMNUC G5 1S	R88M-K75030	750	80×80	W5-19M					
		R88M-1M75030								

Notes: 1. The table shows only a portion of the model numbers for motors. For details regarding model numbers, please see the catalog for each respective motor manufacturer.
 2. If the maximum torque for motors exceeds the permissible input torque (p. 83), please consider a safety measure to limit the torque.
 3. When installing a motor other than the motor model numbers listed above, contact THK.

Motor Wrap Housing A

SKR55
20

SKR**	Actuator model
●◇	●: Housing A ◇: Intermediate flange

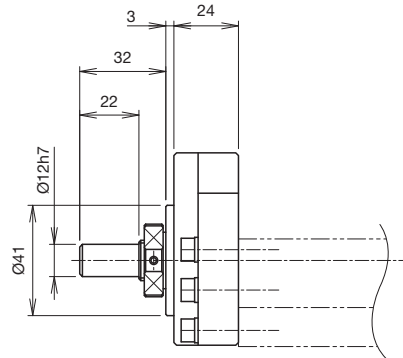
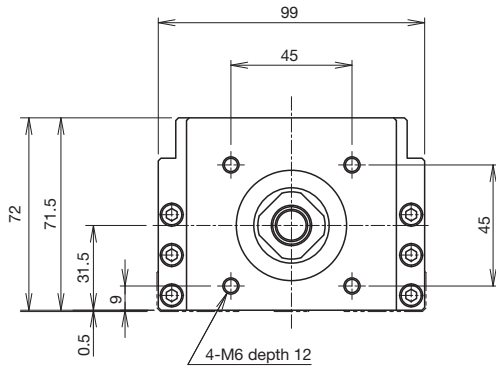

Motor Wrap Specification (Intermediate Flange)

SKR55
WV

Thickness: 6 mm

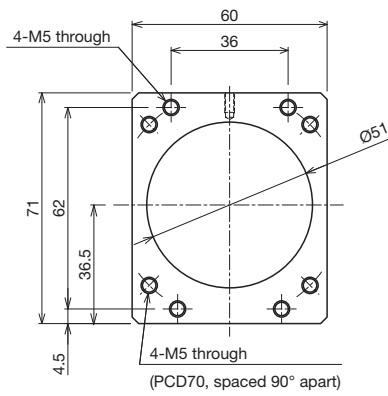

SKR55
W5

Thickness: 6 mm

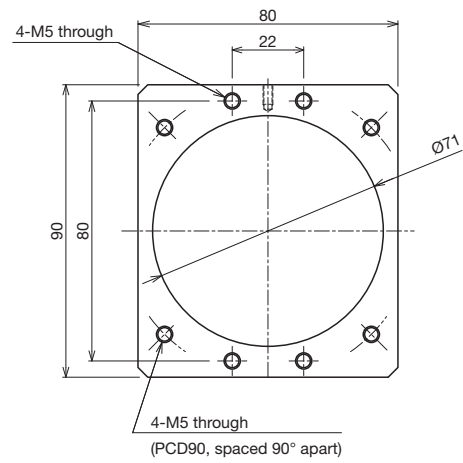

SKR55
WZ

Thickness: 6 mm

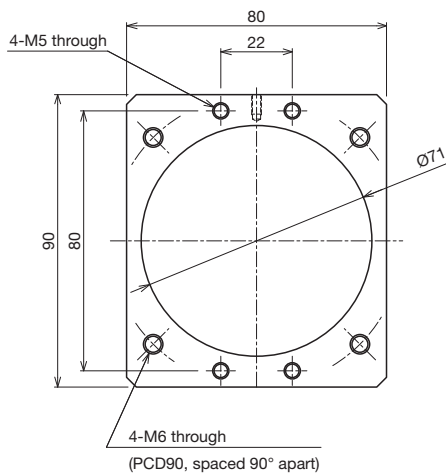

SKR65 A/B

Direct motor coupling	Motor wrap	Width 130 mm	Height 65 mm	Max. stroke 1,490 mm
-----------------------	------------	--------------	--------------	----------------------

Model Number Coding

Model	Ball screw lead	Block type	Stroke	Accuracy grade	With/without motor	Cover	Sensors	Housing A/ Intermediate flange
①	②	③	④	⑤	⑥	⑦	⑧	⑨
SKR65	25	A	0790	P	0	1	2	AZ
SKR65	20: 20 mm 25: 25 mm 30: 30 mm 50: 50 mm	A: x1 B: x2	0640: 640 mm to 1490: 1,490 mm	No symbol: Normal grade H: High accuracy grade P: Precision grade	With direct coupling 0: Direct coupling (without motor) 1: Direct coupling (THK will purchase and mount the motor you specify.) With motor wrap R1: Non-standard side wrap (without motor) R2: Standard side wrap (without motor) R3: Bottom side wrap (without motor) R4: Non-standard side wrap (THK will purchase and mount the motor you specify.) R5: Standard side wrap (THK will purchase and mount the motor you specify.) R6: Bottom side wrap (THK will purchase and mount the motor you specify.)	0: Without cover 1: With cover 2: With bellows	0 1 2 6 7 B E H L J M	With direct coupling A0 AV AZ A5 A6 30 With motor wrap WV - 14M WZ - 16M WZ - 19M W5 - 19M
			When selecting 2: With bellows for ⑦ Cover, specify the stroke with bellows. → p. 109 to p. 110			When selecting "0": A coupling is not provided. Indicate when placing an order if a coupling is required.		
			When selecting "1," "R4," "R5," or "R6": The specified motor will be installed. Indicate the motor cable direction separately. Select ⑨ Intermediate flange to match the specified motor.			Sensor details → p. 103 With direct coupling → p. 105 With motor wrap → p. 107		

③ Block Type

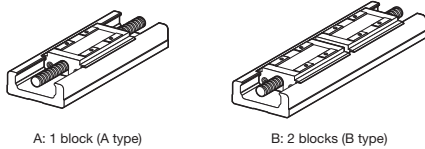

⑥ Motor Mounting Method

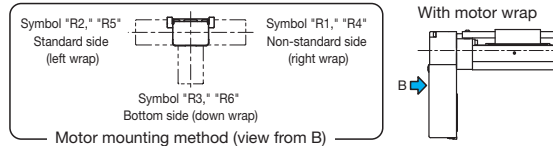

Selection Materials

Basic Specifications

LM Guide	Basic dynamic load rating C (N)		74,400			
	Basic static load rating C_0 (N)		81,600			
	Radial clearance (mm)	Normal grade/High accuracy grade (H)	-0.008 to 0			
		Precision grade (P)	-0.022 to -0.008			
	Geometric moment of inertia	I_x (mm ⁴)	4.51 × 10 ⁶			
I_y (mm ⁴)		5.73 × 10 ⁶				
Mass (kg/m)		22.1				
Ball screw	Ball screw lead (mm)		20	25	30	50
	Basic dynamic load rating C_a (N)	Normal grade/High accuracy grade (H)	12,100	12,000	8,200	7,600
		Precision grade (P)				
	Basic static load rating C_{0a} (N)	Normal grade/High accuracy grade (H)	21,600	22,000	14,500	12,600
		Precision grade (P)				
	Screw shaft diameter (mm)		Ø25			
	Thread minor diameter (mm)		Ø22.1			
Ball center-to-center diameter (mm)		Ø25.75				
Permissible rotational speed ⁵ (min ⁻¹)	Normal grade/High accuracy grade (H)	5,000		3,600		
	Precision grade (P)					
Bearing (Fixed side)	Axial direction	Basic dynamic load rating C_a (N)	13,700			
		Static permissible load P_{0a} (N)	5,830			
Permissible input torque (N·m)	Direct coupling	20.6				
	Motor wrap	6.4				
Static permissible moment ^{4,5} (N·m)		M_c : 1,366 (7,702), M_B : 1,366 (7,702), M_A : 3,868 (7,736)				
Running life ⁶ (km)		10,000				
Standard grease/Grease nipple used		THK AFB-LF Grease/A-M6F				

¹ I_x is the geometric moment of inertia about the X axis.

² I_y is the geometric moment of inertia about the Y axis.

³ The permissible rotational speed may decrease as the stroke becomes longer.

⁴ The value in parentheses is with 2 blocks (B type) attached.

⁵ See p. 116 for the values if "1" or "2" is selected for item ⑦ in the Model Number Coding.

⁶ Calculated under the following conditions.

Stroke: 1,190 mm (A type), 1,040 mm (B type) / Speed: 1,000 mm/s (for 20 mm lead), 1,250 mm/s (for 25 mm lead), 1,500 mm/s (for 30 mm lead), 2,500 mm/s (for 50 mm lead) / Load mass: Maximum load capacity (p. 9) / Acceleration/deceleration: As when set to maximum load capacity (p. 9) / Center of gravity: Center of the table's upper surface.

Notes: 1. Customized products can also be made to handle special environments or large axial loads (25% or more of the basic dynamic load rating C_a). Consult with THK.

2. LM Guide load rating is the load rating per block.

Accuracy

Accuracy grade	Item	Stroke ⁷			
		790	990	1,190	1,490
Normal grade (no symbol)	Positioning repeatability (mm)	±0.01			±0.012
	Positioning accuracy (mm)	Not specified			
	Running parallelism (vertical direction) (mm)	Not specified			
	Backlash (mm)	0.05			
	Starting torque (N·cm)	12			15

Accuracy grade	Item	Stroke ⁷			
		790	990	1,190	1,490
High accuracy grade (H)	Positioning repeatability (mm)	±0.008			
	Positioning accuracy (mm)	0.18	0.20		0.28
	Running parallelism (vertical direction) (mm)	0.05		0.055	
	Backlash (mm)	0.05			
	Starting torque (N·cm)	12			15

Accuracy grade	Item	Stroke ⁷		
		790	990	1,190
Precision grade (P)	Positioning repeatability (mm)	±0.005		
	Positioning accuracy (mm)	0.035		0.04
	Running parallelism (vertical direction) (mm)	0.025		0.03
	Backlash (mm)	0.005		
	Starting torque (N·cm)	20		22

⁷ Stroke with 1 block (A type).

Notes: 3. Precision evaluation in accordance with THK standards.

4. Measured using a motor for inspection. With motor wrap specifications, measurements are not made in the completed motor wrap state.

5. The starting torque represents the value when containing THK AFB-LF Grease.

6. The starting torque may exceed standards if using vacuum grease, clean room grease, or other high-viscosity greases, so care should be taken when selecting a motor.

7. Contact THK for accuracy higher than the standard stroke.

Geometric Moment of Inertia

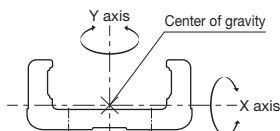

Static Permissible Moment

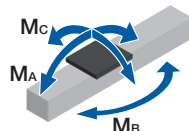

Motor Selection Information

Stroke ¹ (mm)	Outer rail length (mm)	LM Guide				Ball screw		Motor mounting part	
		Moving part mass (kg)			Sliding resistance value ² (N)	Lead (mm)	Shaft length (mm)	Direct coupling	Motor wrap
		Block mass	Sub-table mass	Total mass				Shaft end diameter (mm)	Timing pulley (sum of two) Inertial moment x 10 ⁻⁴ (kg·m ²)
790 to 1,490	980 to 1,680	A type: 3.0 B type: 6.0	A type: 3.7 B type: 7.4	A type: 6.7 B type: 13.4	24.1	20, 25, 30, 50	1,059 to 1,759	Ø15h7	2.065

¹ Stroke with 1 block (A type).

² Value with 1 block (A type). This value is the sum of the rolling resistance value and seal resistance value.

Note: Refer to p. 105 for applicable couplings.

Permissible Overhang Length³

Horizontal

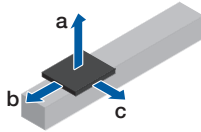

Wall-Mounted

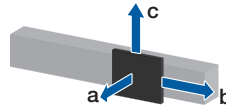

Vertical

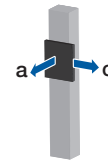

Estimated motor capacity 750 W	Ball screw lead (mm)	Load mass (kg)	a	b	c	
			(mm)	(mm)	(mm)	
Direct coupling	A type	20	16	900	400	780
			32.5	610	200	380
			65.5	270	90	190
		25	15	900	430	830
			30	670	210	410
			60	300	100	200
		30	13	1,300	500	960
			26.5	760	240	470
			53	350	120	230
		50	4.5	1,300	1,300	1,300
			9	1,300	720	1,300
			18	1,150	360	690
	14.5		1,300	1,300	1,300	
	29.5		1,300	1,280	840	
	59		1,300	640	420	
	B type	20	13	1,300	1,300	1,300
			26.5	1,300	1,300	940
			53.5	1,300	700	460
		25	10	1,300	1,300	1,300
			20.5	1,300	1,300	1,210
			41.5	1,300	910	600
		30	6	1,300	1,300	1,300
			12.5	1,300	1,300	1,300
			25	1,300	1,300	990
8.5			1,300	760	1,300	
17.5			1,190	370	710	
35.5			560	180	350	
Motor wrap	A type	20	9.5	1,300	680	1,300
			19.5	1,060	330	640
			39	500	160	320
		25	9	1,300	720	1,300
			18	1,150	360	690
			36.5	540	170	340
	50	4.5	1,300	1,300	1,300	
		9	1,300	720	1,300	
		18	1,150	360	690	
		10.5	1,300	1,300	1,300	
		21	1,300	1,300	1,180	
		42.5	1,300	890	580	
B type	20	10.5	1,300	1,300	1,300	
		21.5	1,300	1,300	1,160	
		43	1,300	870	580	
	25	8.5	1,300	1,300	1,300	
		17	1,300	1,300	1,300	
		34	1,300	1,110	730	
	30	6	1,300	1,300	1,300	
		12.5	1,300	1,300	1,300	
		25	1,300	1,300	990	

Estimated motor capacity 750 W	Ball screw lead (mm)	Load mass (kg)	a	b	c	
			(mm)	(mm)	(mm)	
Direct coupling	A type	20	16	710	690	1,300
			32.5	320	320	1,200
			65.5	120	140	590
		25	15	770	750	1,300
			30	350	360	1,300
			60	140	160	650
		30	13	890	860	1,300
			26.5	410	410	1,300
			53	170	190	730
		50	4.5	1,300	1,300	1,300
			9	1,300	940	1,300
			18	630	450	1,300
	14.5		1,300	1,300	1,300	
	29.5		780	1,090	1,300	
	59		360	540	970	
	B type	20	13	1,300	1,300	1,300
			26.5	880	1,220	1,300
			53.5	400	600	1,300
		25	10	1,300	1,300	1,300
			20.5	1,150	1,300	1,300
			41.5	540	770	1,300
		30	6	1,300	1,300	1,300
			12.5	1,300	1,300	1,300
			25	930	1,290	1,300
8.5			1,300	1,300	1,300	
17.5			650	630	1,300	
35.5			290	300	1,100	
Motor wrap	A type	20	9.5	1,250	1,180	1,300
			19.5	570	570	1,300
			39	250	270	1,000
		25	9	1,300	1,260	1,300
			18	630	610	1,300
			36.5	280	290	1,070
	50	4.5	1,300	1,300	1,300	
		9	1,300	940	1,300	
		18	630	450	1,300	
		10.5	1,300	1,300	1,300	
		21	1,120	1,300	1,300	
		42.5	520	760	1,300	
B type	20	10.5	1,300	1,300	1,300	
		21.5	1,100	1,300	1,300	
		43	510	750	1,300	
	25	8.5	1,300	1,300	1,300	
		17	1,300	1,300	1,300	
		34	670	950	1,300	
	30	6	1,300	1,300	1,300	
		12.5	1,300	1,300	1,300	
		25	930	1,290	1,300	

Estimated motor capacity 750 W	Ball screw lead (mm)	Load mass (kg)	a	c	
			(mm)	(mm)	
Direct coupling	A type	20	7	660	1,280
			14.5	290	620
			29	110	310
		25	6	780	1,300
			12	360	750
			24	150	370
		30	4.5	1,060	1,300
			9.5	470	940
			19	210	470
		50	1.5	1,300	1,300
			3.5	1,300	1,300
			7	660	1,090
	5.5		1,300	1,300	
	11.5		1,300	1,300	
	23.5		1,180	1,050	
	B type	20	5	1,300	1,300
			10	1,300	1,300
			20	1,300	1,240
		25	3.5	1,300	1,300
			7	1,300	1,300
			14	1,300	1,300
		30	1.5	1,300	1,300
			3	1,300	1,300
			6	1,300	1,300
3.5			1,300	1,300	
7			660	1,280	
14.5			290	620	
Motor wrap	A type	20	4	1,200	1,300
			8	570	1,120
			16.5	250	540
		25	3.5	1,300	1,300
			7.5	610	1,200
			15.5	270	580
	50	1.5	1,300	1,300	
		3.5	1,300	1,300	
		7	660	1,300	
		3.5	1,300	1,300	
		7.5	1,300	1,300	
		15	1,300	1,300	
B type	20	3.5	1,300	1,300	
		7.5	1,300	1,300	
		15	1,300	1,300	
	25	3.5	1,300	1,300	
		7.5	1,300	1,300	
		15	1,300	1,300	
	30	2.5	1,300	1,300	
		5.5	1,300	1,300	
		11.5	1,300	1,300	
		1	1,300	1,300	
		2.5	1,300	1,300	
		5.5	1,300	1,300	

³ This is the value with the service life of the LM Guide limited to 10,000 km. The calculation conditions are as follows.
Stroke: 1,140 mm (A type), 990 mm (B type) / Acceleration/deceleration: 0.3 G / Speed: 1,000 mm/s (for 20 mm lead), 1,240 mm/s (for 25 mm lead), 1,500 mm/s (for 30 mm lead), 2,500 mm/s (for 50 mm lead) / Overhang direction: Loaded in only a single direction. Dimensions a, b, and c are from the center of the table's upper surface.

With Cover
Direct Motor Coupling

Dimensions

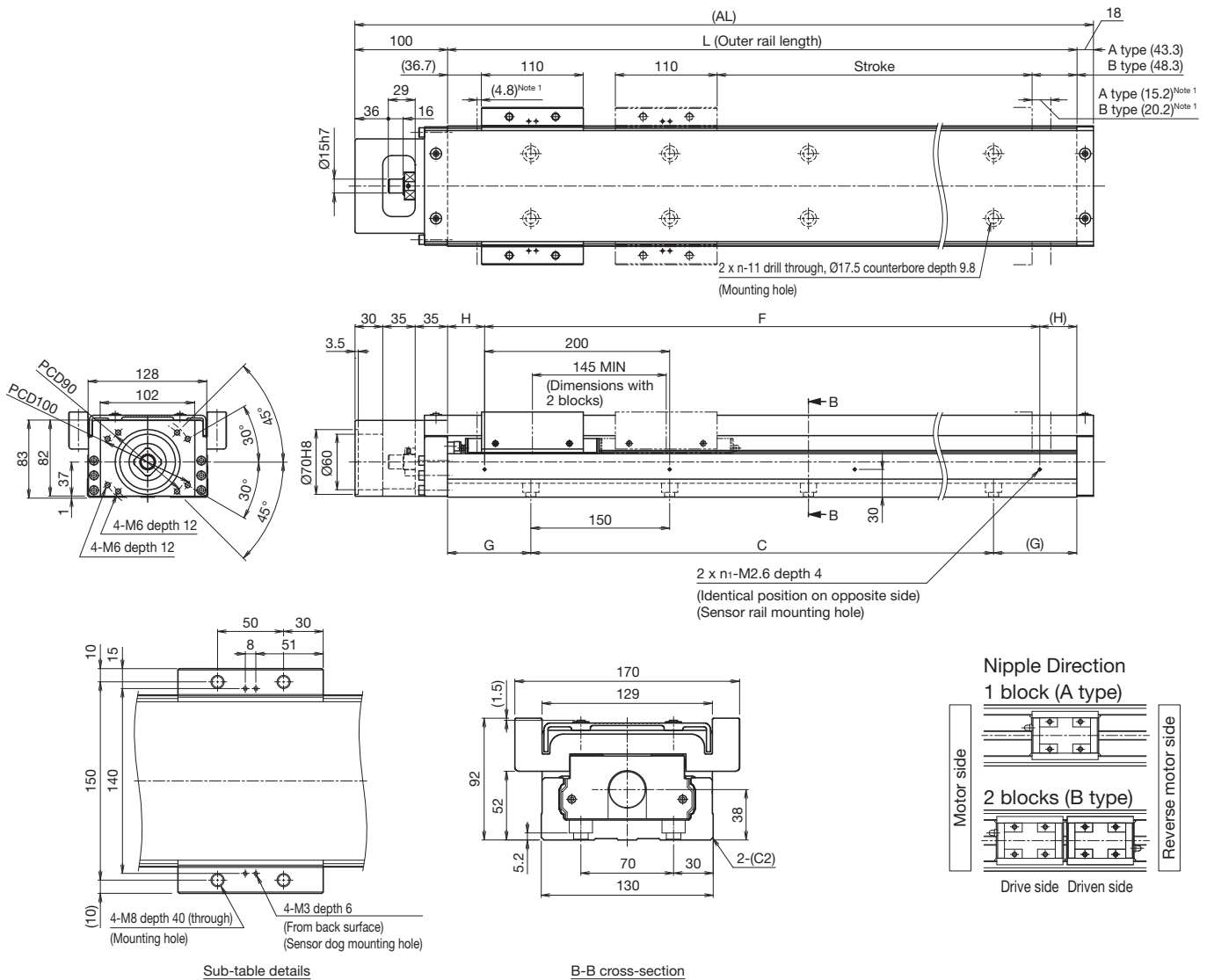

¹ Dimensions from the mechanical stopper to the stroke start position.

Stroke (mm) (Stroke between mechanical stoppers)	A type	790 (810)	990 (1,010)	1,190 (1,210)	1,490 (1,510)
	B type ²	640 (665)	840 (865)	1,040 (1,065)	1,340 (1,365)
Maximum speed ³ (mm/s)	Ball screw lead: 20 mm	1,470	970	690	450
					-
	Ball screw lead: 25 mm	1,810	1,200	850	550
					-
Ball screw lead: 30 mm	Normal grade/High accuracy grade	2,210	1,460	1,030	670
	Precision grade				-
Ball screw lead: 50 mm	Normal grade/High accuracy grade	3,000	2,350	1,680	1,100
	Precision grade				-
Dimensions (mm)	AL	1,098	1,298	1,498	1,798
	L	980	1,180	1,380	1,680
	C	900	1,050	1,200	1,500
	G	40	65	90	90
	F	800	1,000	1,200	1,600
No. of mounting holes	n	7	8	9	11
	n ₁	5	6	7	9
Mass ⁴ (kg)		33.5	38.9	44.3	52.4

² The value with 2 blocks (B type) attached.

³ The maximum speed is restricted by the actuator's permissible speed.

⁴ The mass with 2 blocks (B type) has 6.7 kg added.

Without Cover
Direct Motor Coupling

Dimensions

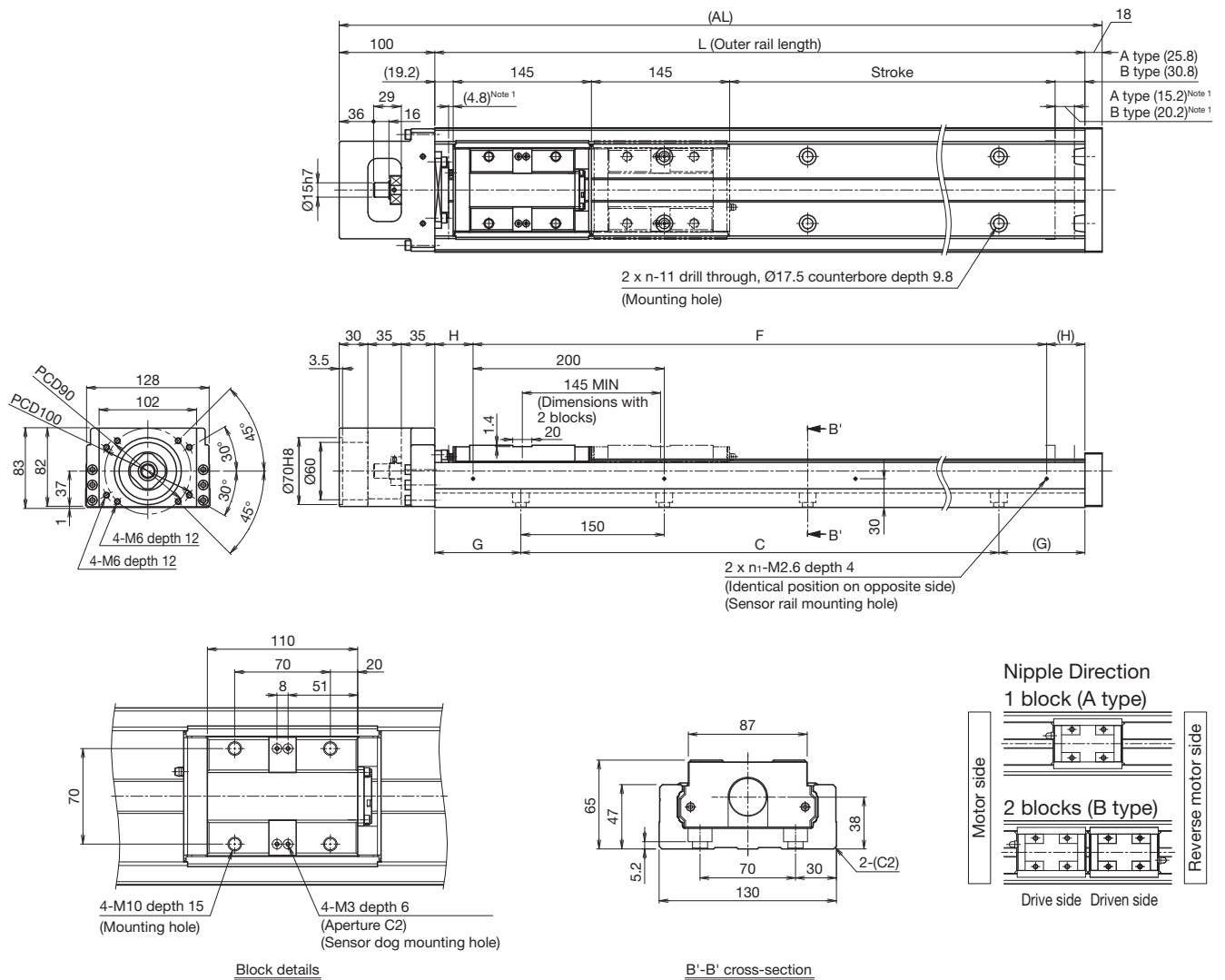

¹ Dimensions from the mechanical stopper to the stroke start position.

Stroke (mm) (Stroke between mechanical stoppers)	A type	790 (810)	990 (1,010)	1,190 (1,210)	1,490 (1,510)	
	B type ²	640 (665)	840 (865)	1,040 (1,065)	1,340 (1,365)	
Maximum speed ³ (mm/s)	Ball screw lead: 20 mm	Normal grade/High accuracy grade	1,470	970	690	450
		Precision grade	-	-	-	-
	Ball screw lead: 25 mm	Normal grade/High accuracy grade	1,810	1,200	850	550
		Precision grade	-	-	-	-
Ball screw lead: 30 mm	Normal grade/High accuracy grade	2,210	1,460	1,030	670	
	Precision grade	-	-	-	-	
Ball screw lead: 50 mm	Normal grade/High accuracy grade	3,000	2,350	1,680	1,100	
	Precision grade	-	-	-	-	
Dimensions (mm)	AL	1,098	1,298	1,498	1,798	
	L	980	1,180	1,380	1,680	
	C	900	1,050	1,200	1,500	
	G	40	65	90	90	
	F	800	1,000	1,200	1,600	
	H	90	90	90	40	
No. of mounting holes	n	7	8	9	11	
	n ₁	5	6	7	9	
Mass ⁴ (kg)		30.3	35.5	40.7	48.4	

² The value with 2 blocks (B type) attached.

³ The maximum speed is restricted by the actuator's permissible speed.

⁴ The mass with 2 blocks (B type) has 3 kg added.

With Cover
Motor Wrap

Dimensions

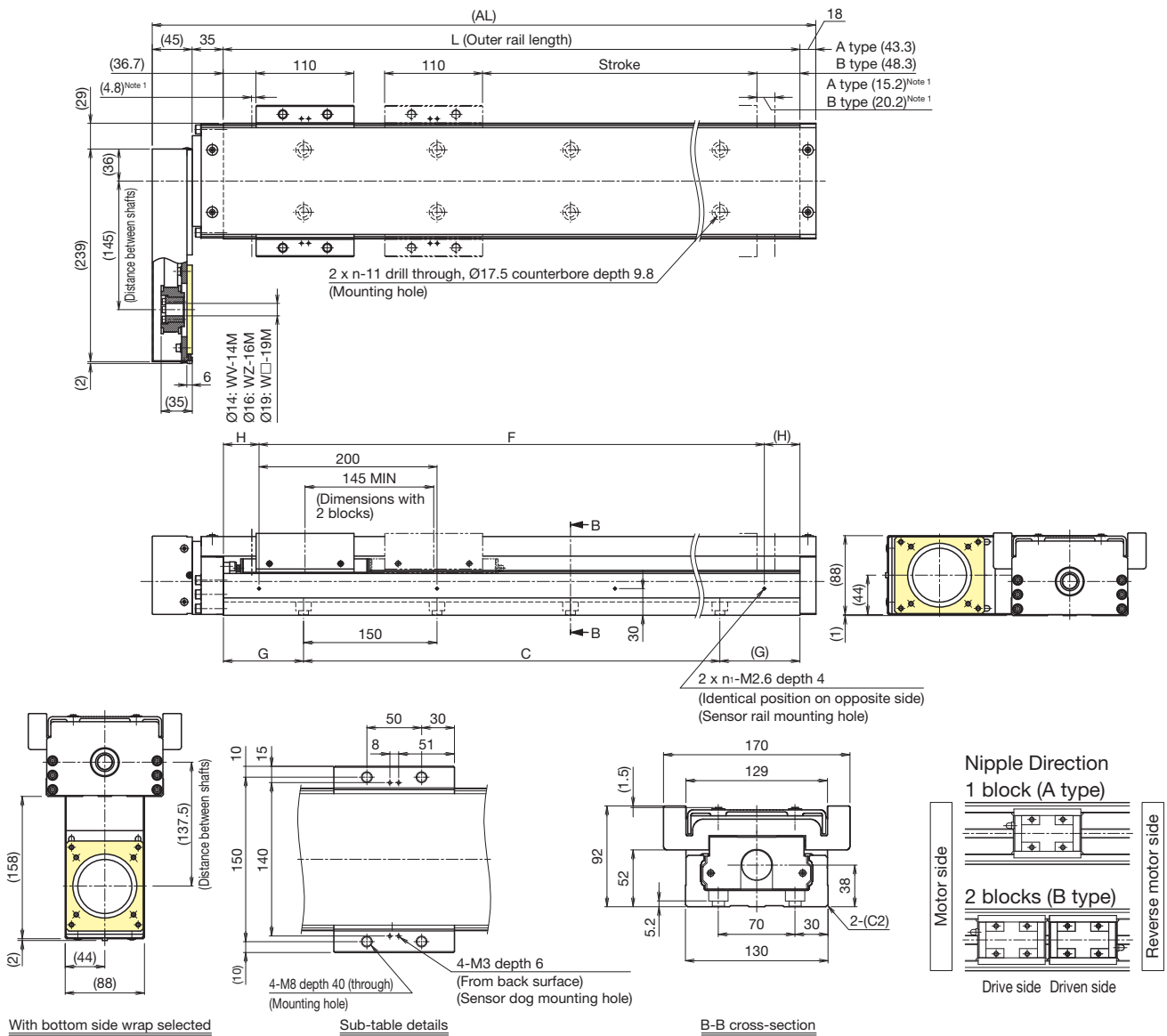

¹ Dimensions from the mechanical stopper to the stroke start position.

Stroke (mm) (Stroke between mechanical stoppers)	A type	790 (810)	990 (1,010)	1,190 (1,210)	1,490 (1,510)	
	B type ²	640 (665)	840 (865)	1,040 (1,065)	1,340 (1,365)	
Maximum speed ³ (mm/s)	Ball screw lead: 20 mm	Normal grade/High accuracy grade	1,470	970	690	450
		Precision grade	-	-	-	-
	Ball screw lead: 25 mm	Normal grade/High accuracy grade	1,810	1,200	850	550
		Precision grade	-	-	-	-
Ball screw lead: 30 mm	Normal grade/High accuracy grade	2,210	1,460	1,030	670	
	Precision grade	-	-	-	-	
Ball screw lead: 50 mm	Normal grade/High accuracy grade	3,000	2,350	1,680	1,100	
	Precision grade	-	-	-	-	
Dimensions (mm)	AL	1,078	1,278	1,478	1,778	
	L	980	1,180	1,380	1,680	
	C	900	1,050	1,200	1,500	
	G	40	65	90	90	
	F	800	1,000	1,200	1,600	
	H	90	90	90	40	
No. of mounting holes	n	7	8	9	11	
	n ₁	5	6	7	9	
Mass ⁴ (kg)		35.1	40.5	45.9	54	

² The value with 2 blocks (B type) attached.

³ The maximum speed is restricted by the actuator's permissible speed.

⁴ The mass with 2 blocks (B type) has 6.7 kg added.

Without Cover
Motor Wrap

Dimensions

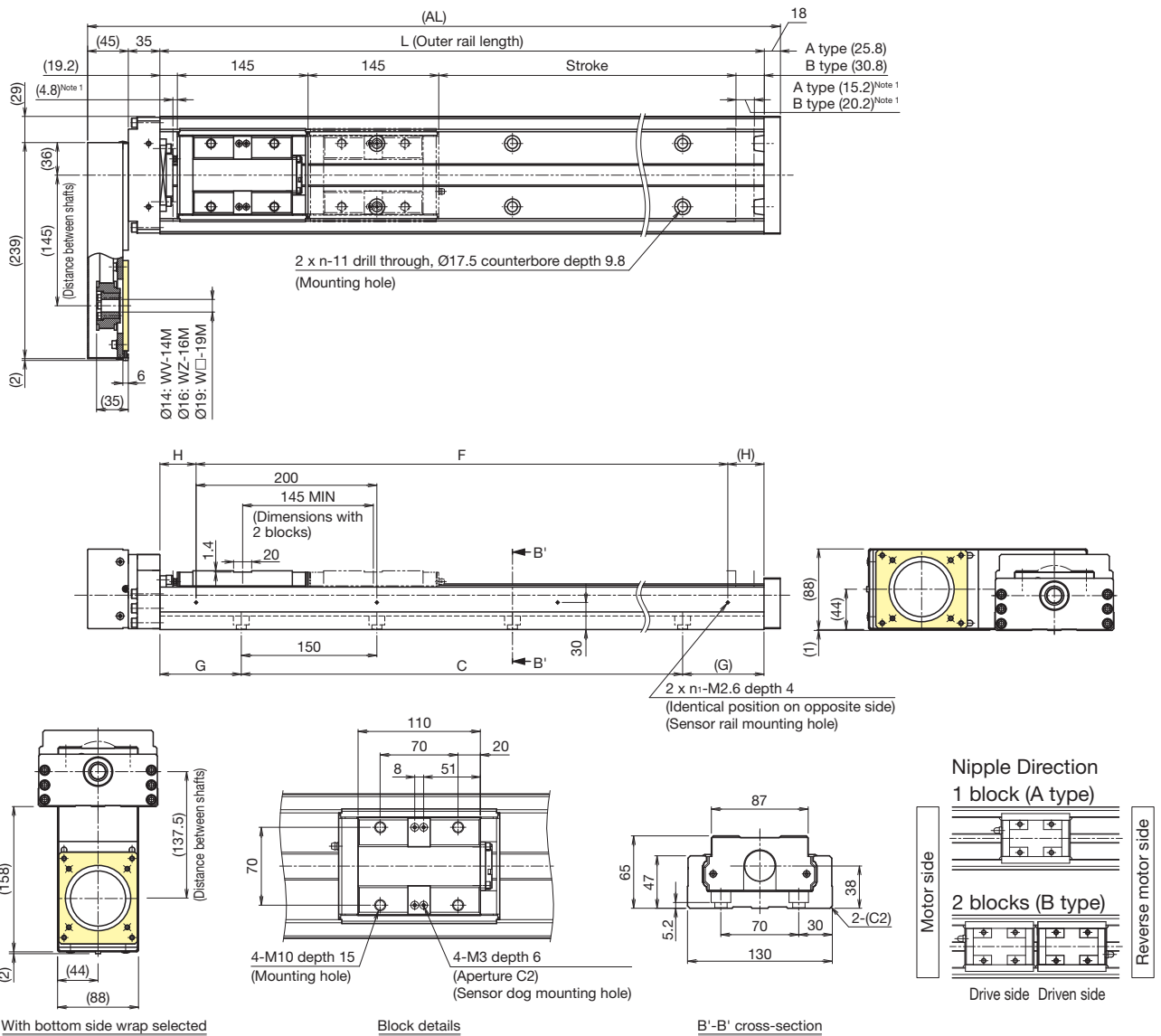

¹ Dimensions from the mechanical stopper to the stroke start position.

Stroke (mm) (Stroke between mechanical stoppers)	A type	790 (810)	990 (1,010)	1,190 (1,210)	1,490 (1,510)	
	B type ²	640 (665)	840 (865)	1,040 (1,065)	1,340 (1,365)	
Maximum speed ³ (mm/s)	Ball screw lead: 20 mm	Normal grade/High accuracy grade	1,470	970	690	450
		Precision grade	-	-	-	-
	Ball screw lead: 25 mm	Normal grade/High accuracy grade	1,810	1,200	850	550
		Precision grade	-	-	-	-
Maximum speed ³ (mm/s)	Ball screw lead: 30 mm	Normal grade/High accuracy grade	2,210	1,460	1,030	670
		Precision grade	-	-	-	-
	Ball screw lead: 50 mm	Normal grade/High accuracy grade	3,000	2,350	1,680	1,100
		Precision grade	-	-	-	-
Dimensions (mm)	AL	1,078	1,278	1,478	1,778	
	L	980	1,180	1,380	1,680	
	C	900	1,050	1,200	1,500	
	G	40	65	90	90	
	F	800	1,000	1,200	1,600	
	H	90	90	90	40	
No. of mounting holes	n	7	8	9	11	
	n ₁	5	6	7	9	
Mass ⁴ (kg)		31.9	37.1	42.3	50	

² The value with 2 blocks (B type) attached.

³ The maximum speed is restricted by the actuator's permissible speed.

⁴ The mass with 2 blocks (B type) has 3 kg added.

Options

Sensors

Optional photo sensors and proximity sensors are available. Sensor-equipped models also feature a dedicated sensor rail and sensor dog.

Sensors, sensor rails, and sensor dogs can be mounted on both sides when the stroke is less than 70 mm.

Mounting example

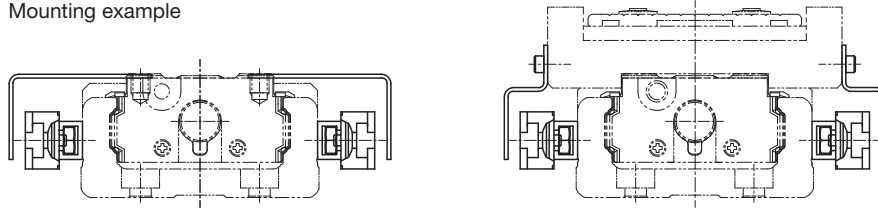

Symbol	Description	Model	Accessories
0	None	-	-
1	With sensor rail	-	Mounting screws, sensor rail (x1 or 2)
2	Photo sensor ¹ (x3)	EE-SX671 (OMRON Corporation)	Mounting screws, nuts, sensor dog (x1 or 2), sensor rail (x1 or 2), mounting plates (x3), connectors (EE-1001 x3)
6	Photo sensor ¹ (x3)	EE-SX674 (OMRON Corporation)	Mounting screws, nuts, sensor dog (x1 or 2), sensor rail (x1 or 2), mounting plates (x3), connectors (EE-1001 x3)
7	Proximity sensor N.O. contact ² (x3)	APM-D3A1-001 (Azbil Corporation)	Mounting screws, nuts, sensor dog (x1 or 2), sensor rail (x1 or 2)
B	Proximity sensor N.C. contact ³ (x3)	APM-D3B1-003 (Azbil Corporation)	Mounting screws, nuts, sensor dog (x1 or 2), sensor rail (x1 or 2)
E	Proximity sensor N.O. contact ² (x1) N.C. contact ³ (x2)	APM-D3A1-001 (Azbil Corporation) APM-D3B1-003 (Azbil Corporation)	Mounting screws, nuts, sensor dog (x1 or 2), sensor rail (x1 or 2)
H	Proximity sensor N.O. contact ² (x3)	GX-F12A (Panasonic Industry Co., Ltd.)	Mounting screws, nuts, sensor dog (x1 or 2), sensor rail (x1 or 2)
L	Proximity sensor N.C. contact ³ (x3)	GX-F12B (Panasonic Industry Co., Ltd.)	Mounting screws, nuts, sensor dog (x1 or 2), sensor rail (x1 or 2)
J	Proximity sensor N.O. contact ² (x1) N.C. contact ³ (x2)	GX-F12A (Panasonic Industry Co., Ltd.) GX-F12B (Panasonic Industry Co., Ltd.)	Mounting screws, nuts, sensor dog (x1 or 2), sensor rail (x1 or 2)
M	Proximity sensor N.O. contact ² (x1) (PNP output) N.C. contact ³ (x2) (PNP output)	GX-F12A-P (Panasonic Industry Co., Ltd.) GX-F12B-P (Panasonic Industry Co., Ltd.)	Mounting screws, nuts, sensor dog (x1 or 2), sensor rail (x1 or 2)

¹ The photo sensors can be switched between ON when lit and ON when unlit.

² N.O. contact: Normally open contact point

³ N.C. contact: Normally closed contact point

Notes: 1. If proximity sensors are close to one another, they may not function properly. If that happens, please prepare a type with a different frequency.

2. Mounting of sensors other than those in the table above is possible. Contact THK for details.

Sensor Rail Mounting Dimensions

Mounting only a sensor rail is also possible.

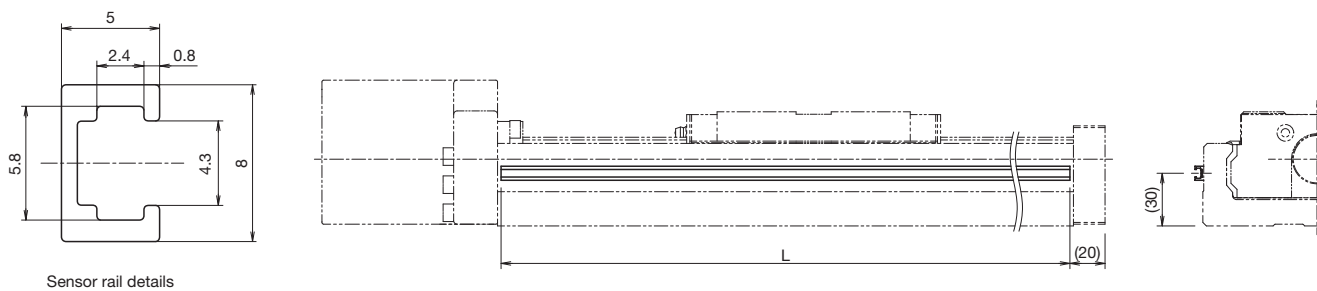

Sensor rail details

Stroke ⁴ (mm)	Outer rail length (mm)	L (mm)
790	980	976
990	1,180	1,176
1,190	1,380	1,376
1,490	1,680	1,676

⁴ Stroke with 1 block (A type).

Photo Sensor Mounting Dimensions

Connector: EE-1001 (OMRON Corporation) x3 included.
To be mounted by the customer.

Without cover

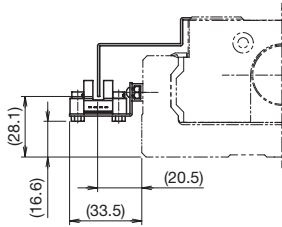

With cover

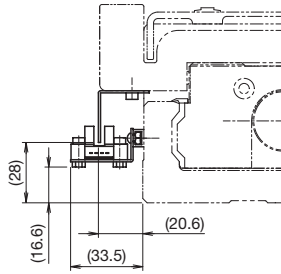

Symbol	Model	Manufacturer
2	EE-SX671	OMRON Corporation

Sensor dog width: 20 mm

Without cover

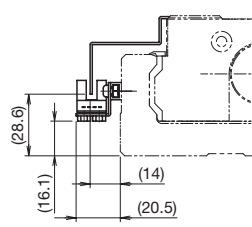

With cover

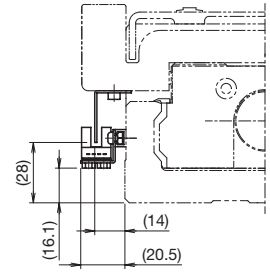

Symbol	Model	Manufacturer
6	EE-SX674	OMRON Corporation

Sensor dog width: 20 mm

Proximity Sensor Mounting Dimensions

Without cover

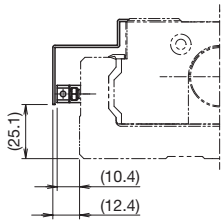

With cover

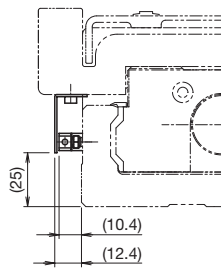

Symbol	Model	Manufacturer
7, B, E	APM-D3A1-001	Azbil Corporation
	APM-D3B1-003	

Sensor dog width: 20 mm

Without cover

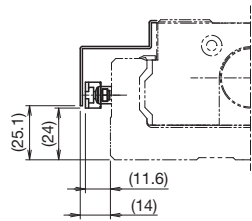

With cover

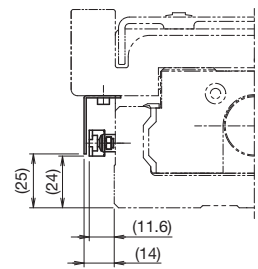

Symbol	Model	Manufacturer
H, L, J	GX-F12A	Panasonic Industry Co., Ltd.
	GX-F12B	
M	GX-F12A-P	
	GX-F12B-P	

Sensor dog width: 20 mm

Options

Intermediate Flange (Direct Coupling)

Several types of intermediate flanges for mounting motors are available.

When selecting "0" or "1" for Model Number Coding ⑥ With/without motor, specify an intermediate flange that matches the motor used.

Compatibility Table: Motors Used, Intermediate Flanges, and Couplings

Motor type	Manufacturer	Motor model		Motor rated output (W)	Flange size	Housing A/ Intermediate flange	Compatible coupling models					
							MIKI PULLEY CO., LTD.	Nabeya Bi-tech Kaisha (NBK)				
AC servo motor	YASKAWA Electric Corporation	Σ -V	SGMJV-02	200	60×60	AV	SFC-035DA2-14B-15B	XGT2-30C-14-15				
			SGMAV-02									
			SGMJV-04	400								
			SGMAV-04									
			SGMJV-06	600								
			SGMJV-08									
		SGMAV-08	750	80×80	AZ	SFC-040DA2-15B-19B	XGT2-39C-15-19					
		Σ -7	SGM7J-02	200	60×60	AV	SFC-035DA2-14B-15B	XGT2-30C-14-15				
			SGM7A-02									
			SGM7J-04	400								
			SGM7A-04									
			SGM7J-06	600								
			SGM7J-08						750	80×80	AZ	SFC-040DA2-15B-19B
		SGM7A-08										
		Σ -X	SGMXJ-02	200	60×60	AV	SFC-035DA2-14B-15B	XGT2-30C-14-15				
			SGMXA-02									
			SGMXJ-04	400								
			SGMXA-04									
	SGMXJ-06		600									
	SGMXA-06											
	SGMXJ-08		750	80×80					AZ	SFC-040DA2-15B-19B	XGT2-39C-15-19	
	SGMXA-08											
	Mitsubishi Electric Corporation	MELSERVO	J4	HG-KR23	200	60×60	AV	SFC-035DA2-14B-15B	XGT2-30C-14-15			
				HG-MR23								
				HG-KR43	400							
				HG-MR43								
			HG-KR73	750	80×80					AZ	SFC-040DA2-15B-19B	XGT2-39C-15-19
			HG-MR73									
		J5	HK-KT23W	200	60×60	AV	SFC-035DA2-14B-15B	XGT2-30C-14-15				
			HK-KT43W	400								
			HK-KT7M3W	750	80×80	AZ	SFC-040DA2-15B-19B	XGT2-39C-15-19				
		JN	HF-KN23	200	60×60	AV	SFC-035DA2-14B-15B	XGT2-30C-14-15				
			HF-KN43	400								
		TAMAGAWA SEIKI CO., LTD.	TBL-iii	TS4607	200	60×60	AV	SFC-035DA2-14B-15B	XGT2-30C-14-15			
	TS4609			400								
	TS4614			750	80×80					AZ	SFC-040DA2-15B-19B	XGT2-39C-15-19
	TBL-iiV		TSM3202	200	60×60	AV	SFC-035DA2-14B-15B	XGT2-30C-14-15				
			TSM3204	400								
			TSM3303	600								
			TSM3304	750					80×80	AZ	SFC-040DA2-15B-19B	XGT2-39C-15-19
			TSM3304	750								
	Panasonic Corporation	MINAS	A5	MSMD08	750	80×80	A5	SFC-040DA2-15B-19B	XGT2-39C-15-19			
MSME08												
A6		MSMF08	750									
		MHMF08										
KEYENCE CORPORATION	SV	SV-M020	200	60×60	AV	SFC-035DA2-14B-15B	XGT2-30C-14-15					
		SV-M040	400									
		SV-M075	750					80×80	AZ	SFC-040DA2-15B-19B	XGT2-39C-15-19	
	SV2	SV2-M020	200	60×60	AV	SFC-035DA2-14B-15B	XGT2-30C-14-15					
		SV2-M040	400									
		SV2-M075	750					80×80	AZ	SFC-040DA2-15B-19B	XGT2-39C-15-19	
SANYO DENKI CO., LTD.	SANMOTION R	R2□A06020	200	60×60	AV	SFC-035DA2-14B-15B	XGT2-30C-14-15					
		R2AA06040	400									
		R2AA08075	750					80×80	AZ	SFC-040DA2-15B-16B	XGT2-39C-15-16	
		R88M-K75030	750					80×80	A5	SFC-040DA2-15B-19B	XGT2-39C-15-19	
OMNUC G5	R88M-1M75030	750										
OMRON Corporation	1S	R88M-1M75030	750	80×80								

Motor type	Manufacturer	Motor model		Flange size	Housing A/ Intermediate flange	Compatible coupling models	
						MIKI PULLEY CO., LTD.	Nabeya Bi-tech Kaisha (NBK)
Stepper motor	ORIENTAL MOTOR CO., LTD.	α step	AZ9*, AR9*	85×85	A6	SFC-035DA2-14B-15B	XGT2-34C-14-15
		5-phase RK II	RKS59*	85×85	A6	SFC-035DA2-14B-15B	XGT2-34C-14-15

Notes: 1. The table shows only a portion of the model numbers for motors. For details regarding model numbers, please see the catalog for each respective motor manufacturer.

2. If the maximum torque for motors exceeds the permissible input torque (p. 97), please consider a safety measure to limit the torque.

3. When installing a motor other than the motor model numbers listed above, contact THK.

Housing A

SKR65
A0

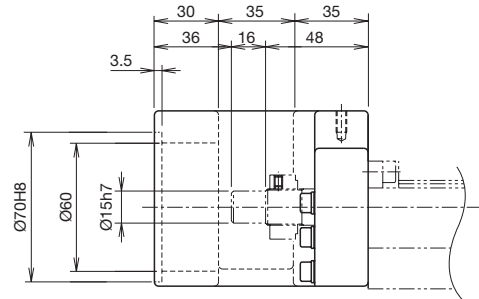
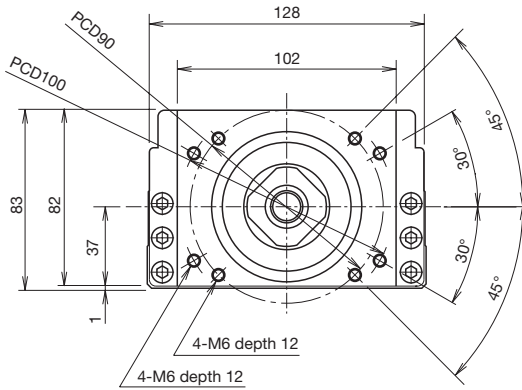

SKR**	Actuator model
●◇	●: Housing A ◇: Intermediate flange

Intermediate Flange

SKR65
AV

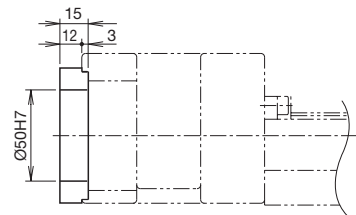
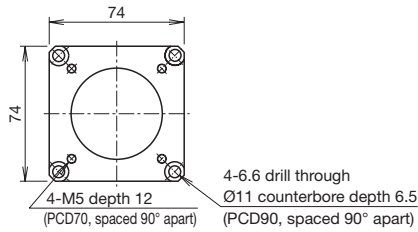

SKR65
A5

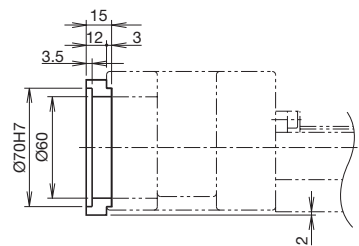
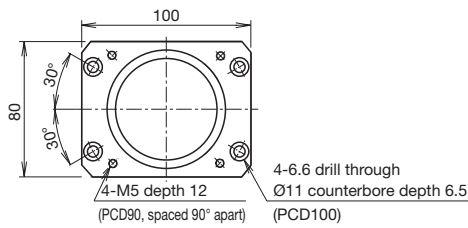

SKR65
A6

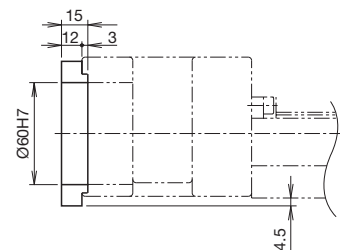
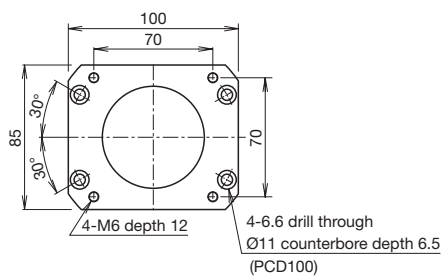

SKR65
AZ

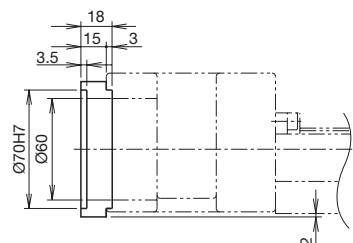
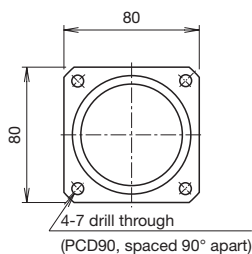

Options

Intermediate Flange (Motor Wrap)

Several types of intermediate flanges for mounting motors are available.

When selecting "R1," "R2," "R3," "R4," "R5," or "R6" for Model Number Coding ⑥ With/without motor, specify an intermediate flange that matches the motor used.

Symbol Coding

Motor wrap symbol ①	Intermediate flange ②	Motor shaft diameter (mm) ③	Motor shaft securing method ④
W	V	14	M
W	Refer to the Compatibility Table: Motors Used and Motor Wrap Symbols below.	Specify a motor shaft diameter. (Refer to the Compatibility Table: Motors Used and Motor Wrap Symbols below.)	M: Friction tightening tool

Motor Shaft Securing Method

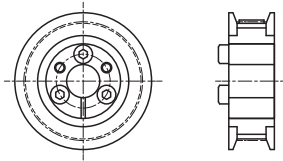

Friction tightening tool

Compatibility Table: Motors Used and Motor Wrap Symbols

Motor type	Manufacturer	Motor model	Motor rated output (W)	Flange size	Housing A/Intermediate flange				
AC servo motor	YASKAWA Electric Corporation	Σ-V	SGMJV-02	200	60×60	WV-14M			
			SGMAV-02	400					
			SGMJV-04						
			SGMAV-04						
			SGMJV-06				600		
			SGMAV-06						
		Σ-7	SGMJV-08		750	80×80	WZ-19M		
			SGMAV-08						
			SGM7J-02	200					
			SGM7A-02						
			SGM7J-04					400	
			SGM7A-04						
		SGM7J-06	600						
		SGM7A-06							
		Σ-X	SGM7J-08	750	80×80	WZ-19M			
			SGM7A-08						
			SGMXJ-02				200		
			SGMXA-02						
	SGMXJ-04		400						
	SGMXA-04								
	SGMXJ-06	600							
	SGMXA-06								
	Mitsubishi Electric Corporation	MELSERVO	J4	HG-MR23	200	60×60	WV-14M		
				HG-KR23					
				HG-MR43				400	
				HG-KR43					
				HG-MR73					750
				HG-KR73					
		J5	HK-KT23W	200	60×60	WV-14M			
			HK-KT43W						
			HK-KT7M3W				750		
			HF-KN23					200	
			HF-KN43				400		
			JN					HF-KN23	200
	HF-KN43	400							
	TAMAGAWA SEIKI CO., LTD.	TBL-III	TS4607	200	60×60	WV-14M			
			TS4609	400					
			TS4614	750					
			TSM3202	200					
		TBL-IV	TSM3204	400	60×60	WV-14M			
TSM3303			600						
TSM3304			750						
TSM3304			750						
Panasonic Corporation	MINAS	A5	MMSD08	750	80×80	W5-19M			
			MSME08						
		A6	MSMF08						
			MHMF08						
KEYENCE CORPORATION	SV	SV-M020	200	60×60	WV-14M				
		SV-M040	400						
		SV-M075	750						
	SV2	SV2-M020	200	60×60	WV-14M				
		SV2-M040	400						
		SV2-M075	750						
SANYO DENKI CO., LTD.	SANMOTION R	R2□A06020	200	60×60	WV-14M				
		R2AA06040	400						
		R2AA08075	750						
OMRON Corporation	OMNUC G5 1S	R88M-K75030	750	80×80	W5-19M				
		R88M-1M75030							

Notes: 1. The table shows only a portion of the model numbers for motors. For details regarding model numbers, please see the catalog for each respective motor manufacturer.
 2. If the maximum torque for motors exceeds the permissible input torque (p. 97), please consider a safety measure to limit the torque.
 3. When installing a motor other than the motor model numbers listed above, contact THK.

Motor Wrap Housing A

SKR65
30

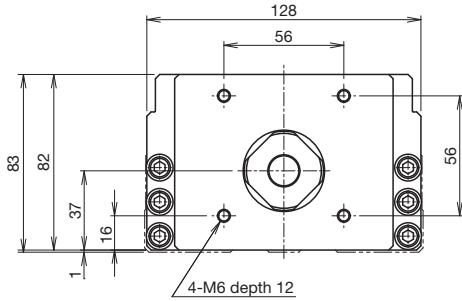

SKR**	Actuator model
●◇	●: Housing A ◇: Intermediate flange

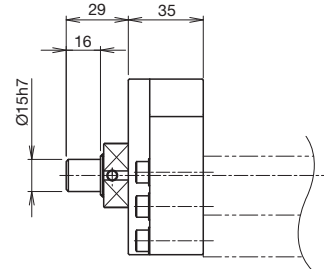

Motor Wrap Specification (Intermediate Flange)

SKR65
WV

Thickness: 6 mm

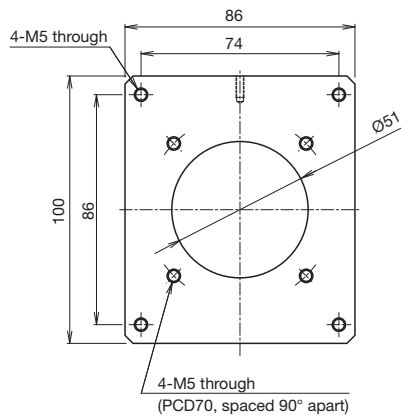

SKR65
W5

Thickness: 6 mm

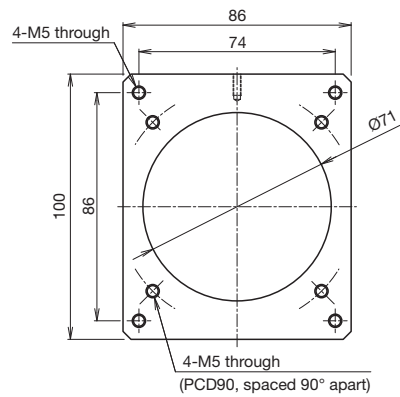

SKR65
WZ

Thickness: 6 mm

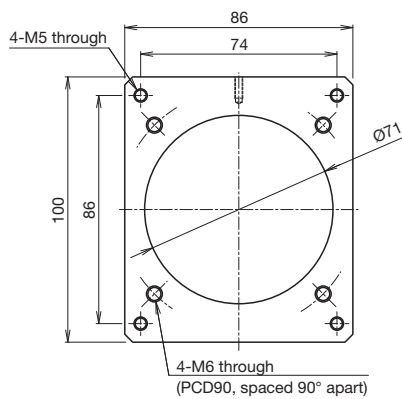

Bellows

In addition to a cover, bellows are available for dustproofing purposes.

SKR-A (1 Block)

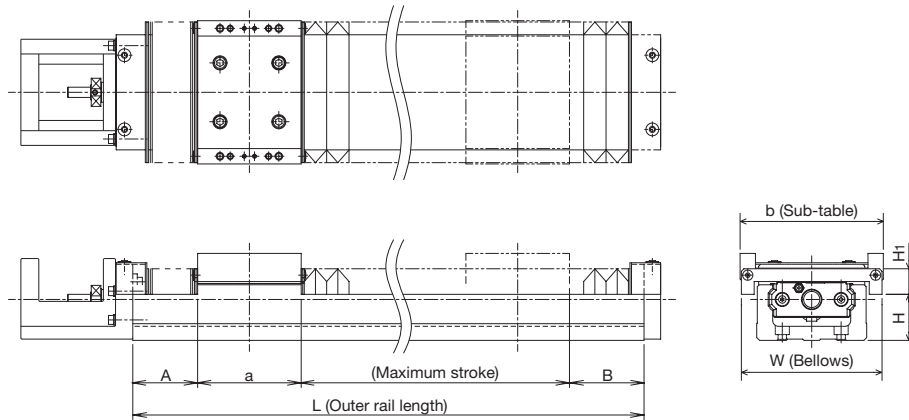

Unit: mm

Model	Stroke	Maximum stroke	Outer rail length L	A	B	a	b	W	H	H _i
SKR20	20	30.8	100	18.8	17.2	33.2	52	60	10	20
	55	67.8	150	25.3	23.7					
	80	93.6	200	37	36.2					
SKR26	50	60.7	150	23.7	17.6	47.4	62	74	18	20
	80	91.6	200	32.8	28.2					
	110	125.6	250	40.8	36.2					
	160	175.6	300	40.8	36.2					
SKR33	30	42.8	150	25.6	27.6	54	86	84	24.5	20
	60	72.8	200	35.6	37.6					
	140	152.8	300	45.6	47.6					
	210	222.8	400	60.6	62.6					
	290	302.8	500	70.6	72.6					
	360	372.8	600	85.6	87.6					
SKR46	140	155.8	340	52.1	51.1	81	112	110	36	20
	210	225.8	440	67.1	66.1					
	290	305.8	540	77.1	76.1					
	360	375.8	640	92.1	91.1					
	440	455.8	740	102.1	101.1					
	510	525.8	840	117.1	116.1					
	590	605.8	940	127.1	126.1					
SKR55 ¹	700	719.6	980	84.6	80.6	95.2	124	154	37	40
	790	809.6	1,080	89.6	85.6					
	870	889.6	1,180	99.6	95.6					
	960	979.6	1,280	104.6	100.6					
	1,050	1,069.6	1,380	109.6	105.6					
SKR65 ¹	680	703.2	980	85.1	81.7	110	170	184	40	47
	860	883.2	1,180	95.1	91.7					
	1,030	1,053.2	1,380	110.1	106.7					
	1,290	1,313.2	1,680	130.1	126.7					

¹ The bellows for models SKR55 and SKR65 are only suitable for horizontal orientation. If the bellows are to be used in other orientations (vertical or wall-mounted), contact THK.

SKR-B (2 Blocks)

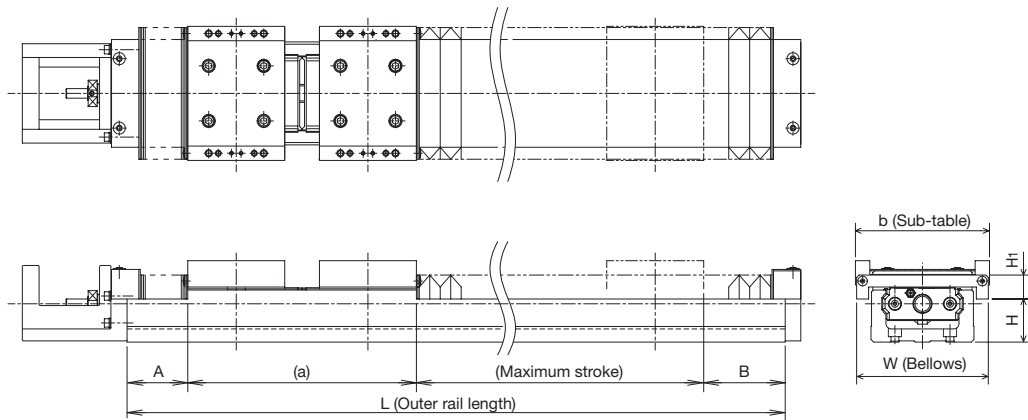

Unit: mm

Model	Stroke ¹	Maximum stroke ¹	Outer rail length L	A	B	a ¹	b	W	H	H ₁
SKR20	25	34.8	150	18.8	17.2	79.2	52	60	10	20
	60	71.8	200	25.3	23.7					
SKR26	35	46.5	200	23.7	17.6	111.6	62	74	18	20
	65	77.4	250	32.8	28.2					
	115	127.4	300	32.8	28.2					
SKR33	80	96.8	300	35.6	37.6	130	86	84	24.5	20
	150	166.8	400	50.6	52.6					
	230	246.8	500	60.6	62.6					
	300	316.8	600	75.6	77.6					
SKR46	60	75.8	340	37.1	36.1	191	112	110	36	20
	130	145.8	440	52.1	51.1					
	210	225.8	540	62.1	61.1					
	280	295.8	640	77.1	76.1					
	360	375.8	740	87.1	86.1					
	430	445.8	840	102.1	101.1					
SKR55 ²	510	525.8	940	112.1	111.1	222.8	124	154	37	40
	590	612	980	74.6	70.6					
	670	692	1,080	84.6	80.6					
	760	782	1,180	89.6	85.6					
	850	872	1,280	94.6	90.6					
SKR65 ²	930	952	1,380	104.6	100.6	254.6	170	184	40	47
	550	578.6	980	75.1	71.7					
	720	748.6	1,180	90.1	86.7					
	900	928.6	1,380	100.1	96.7					
	1,160	1,188.6	1,680	120.1	116.7					

¹ The value with 2 blocks (B type) attached.

² The bellows for models SKR55 and SKR65 are only suitable for horizontal orientation. If the bellows are to be used in other orientations (vertical or wall-mounted), contact THK.

Note: Bellows cannot be attached between sub-tables.

Bellows

SKR-C (1 Short Block)

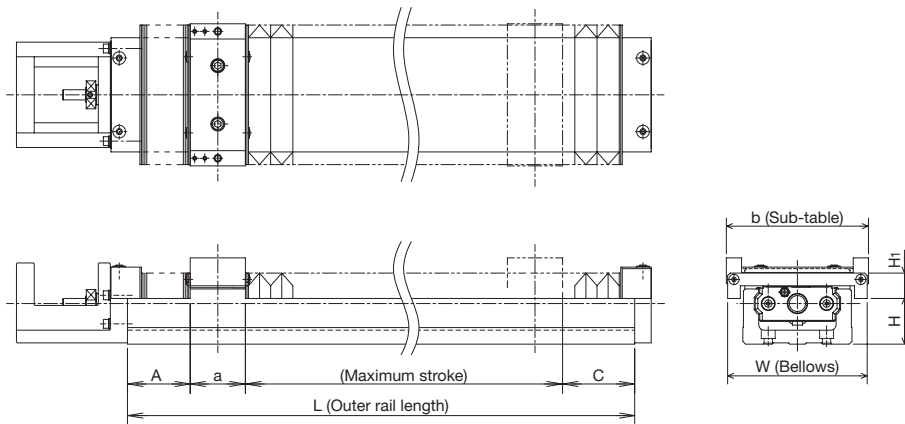

Unit: mm

Model	Stroke	Maximum stroke	Outer rail length L	A	C	a	b	W	H	H ₁
SKR33	45	58.3	150	30.6	32.6	28.5	80	80	21.5	17.5
	85	98.3	200	35.6	37.6					
	155	168.3	300	50.6	52.6					
	235	248.3	400	60.6	62.6					
	305	318.3	500	75.6	77.6					
	385	398.3	600	85.6	87.6					
SKR46	160	178.8	340	57.1	56.1	48	112	110	36	20
	230	248.8	440	72.1	71.1					
	310	328.8	540	82.1	81.1					
	380	398.8	640	97.1	96.1					
	460	478.8	740	107.1	106.1					
	530	548.8	840	122.1	121.1					
	610	628.8	940	132.1	131.1					

SKR-D (2 Short Blocks)

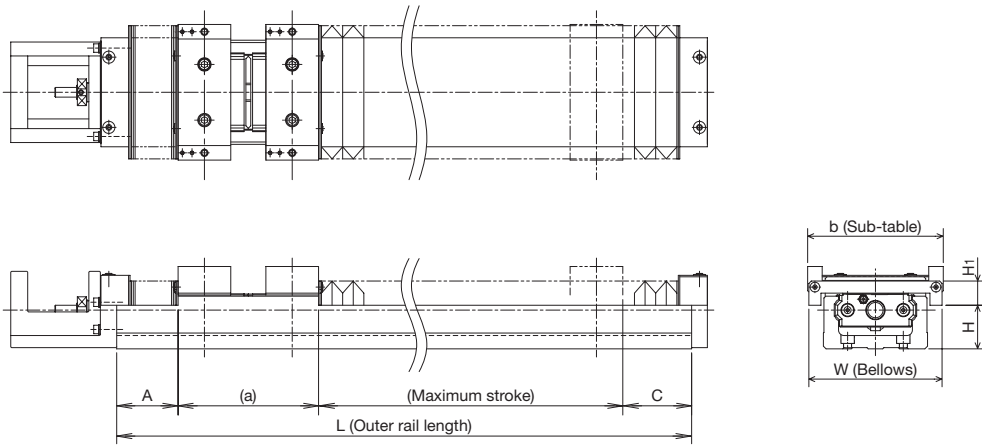

Unit: mm

Model	Stroke ¹	Maximum stroke ¹	Outer rail length L	A	C	a ¹	b	W	H	H ₁
SKR33	45	57.8	200	30.6	32.6	79	86	84	24.5	20
	125	137.8	300	40.6	42.6					
	195	207.8	400	55.6	57.6					
	275	287.8	500	65.6	67.6					
	345	357.8	600	80.6	82.6					
SKR46	110	121.8	340	47.1	46.1	125	112	110	36	20
	180	191.8	440	62.1	61.1					
	260	271.8	540	72.1	71.1					
	330	341.8	640	87.1	86.1					
	410	421.8	740	97.1	96.1					
	480	491.8	840	112.1	111.1					
	560	571.8	940	122.1	121.1					

¹ The value with 2 short blocks (D type) attached.

Note: Bellows cannot be attached between sub-tables.

Maximum Load Capacity Guidelines by Acceleration

Horizontal

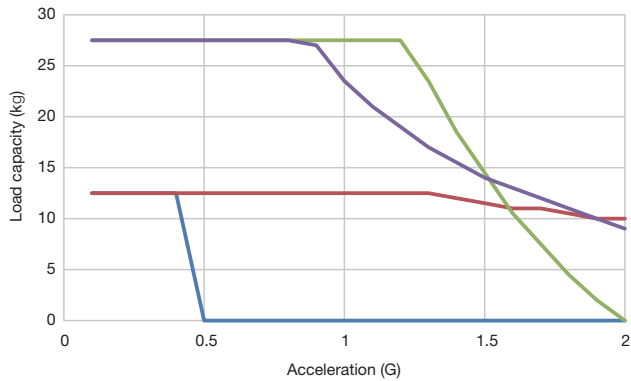

— SKR2001A — SKR2006A — SKR2602A — SKR2606A

Unit: kg

	0.15 G	0.3 G	0.5 G	1 G	1.5 G	2 G
SKR2001A	12.5	12.5	-	-	-	-
SKR2006A	12.5	12.5	12.5	12.5	11.5	10
SKR2602A	27.5	27.5	27.5	27.5	14.5	-
SKR2606A	27.5	27.5	27.5	23.5	14	9

Wall-Mounted

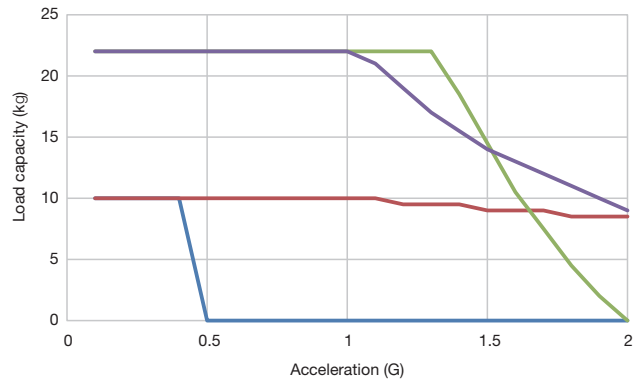

— SKR2001A — SKR2006A — SKR2602A — SKR2606A

Unit: kg

	0.15 G	0.3 G	0.5 G	1 G	1.5 G	2 G
SKR2001A	10	10	-	-	-	-
SKR2006A	10	10	10	10	9	8.5
SKR2602A	22	22	22	22	14.5	-
SKR2606A	22	22	22	22	14	9

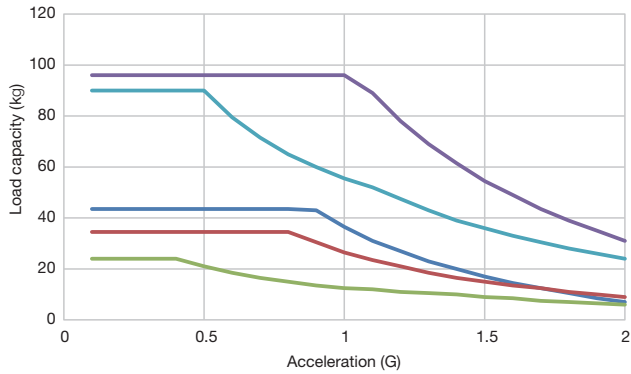

— SKR3306A — SKR3310A — SKR3320A — SKR4610A — SKR4620A

Unit: kg

	0.15 G	0.3 G	0.5 G	1 G	1.5 G	2 G
SKR3306A	43.5	43.5	43.5	36.5	17	7
SKR3310A	34.5	34.5	34.5	26.5	15	9
SKR3320A	24	24	21	12.5	9	6
SKR4610A	96	96	96	96	54.5	31
SKR4620A	90	90	90	55.5	36	24

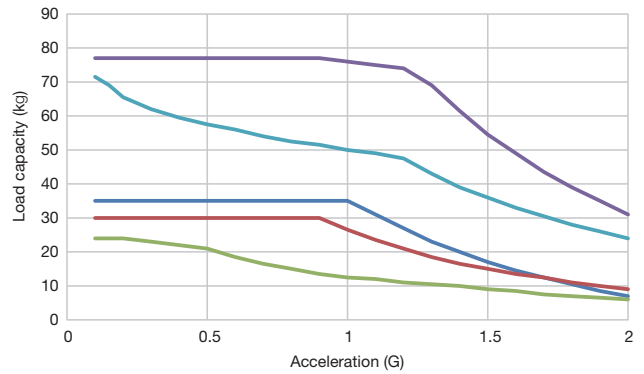

— SKR3306A — SKR3310A — SKR3320A — SKR4610A — SKR4620A

Unit: kg

	0.15 G	0.3 G	0.5 G	1 G	1.5 G	2 G
SKR3306A	35	35	35	35	17	7
SKR3310A	30	30	30	26.5	15	9
SKR3320A	24	23	21	12.5	9	6
SKR4610A	77	77	77	76	54.5	31
SKR4620A	69	62	57.5	50	36	24

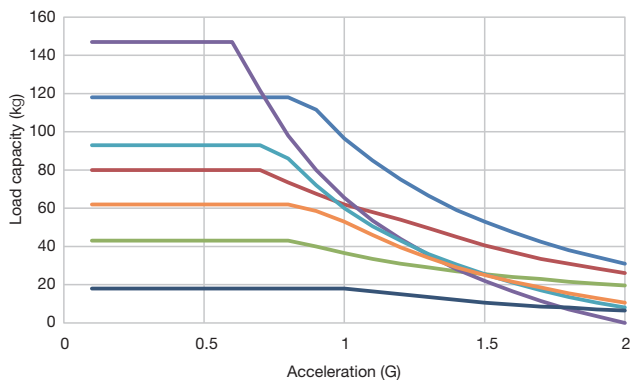

— SKR5520A — SKR5530A — SKR5540A — SKR5550A — SKR6520A — SKR6530A

Unit: kg

	0.15 G	0.3 G	0.5 G	1 G	1.5 G	2 G
SKR5520A	118	118	118	96.5	53	31
SKR5530A	80	80	80	62	40.5	26
SKR5540A	43	43	43	36.5	25.5	19.5
SKR6520A	147	147	147	65.5	22	-
SKR6525A	93	93	93	60	25.5	8
SKR6530A	62	62	62	53	25	10.5
SKR6550A	18	18	18	18	10.5	6.5

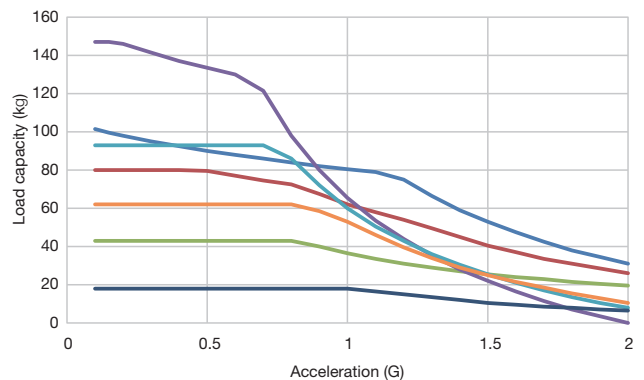

— SKR5520A — SKR5530A — SKR5540A — SKR5550A — SKR6520A — SKR6530A

Unit: kg

	0.15 G	0.3 G	0.5 G	1 G	1.5 G	2 G
SKR5520A	99.5	95	90	80.5	53	31
SKR5530A	80	80	79.5	62	40.5	26
SKR5540A	43	43	43	36.5	25.5	19.5
SKR6520A	147	141.5	133.5	65.5	22	-
SKR6525A	93	93	93	60	25.5	8
SKR6530A	62	62	62	53	25	10.5
SKR6550A	18	18	18	18	10.5	6.5

Vertical

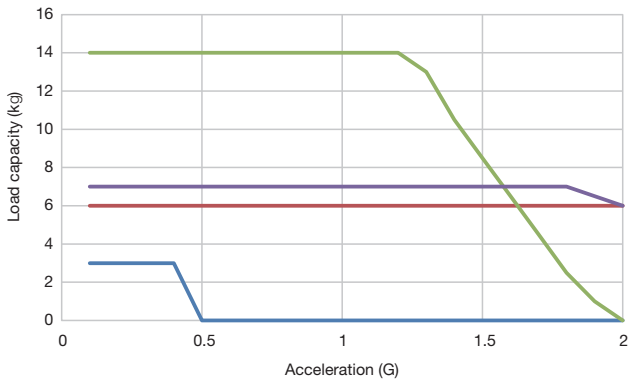

— SKR2001A — SKR2006A — SKR2602A — SKR2606A

Unit: kg

	0.15 G	0.3 G	0.5 G	1 G	1.5 G	2 G
SKR2001A	3	3	-	-	-	-
SKR2006A	6	6	6	6	6	6
SKR2602A	14	14	14	14	8.5	-
SKR2606A	7	7	7	7	7	6

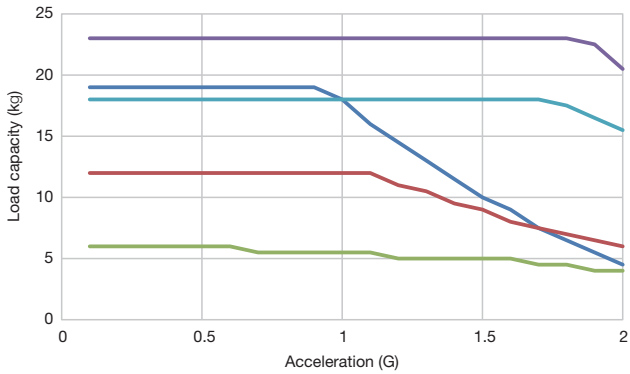

— SKR3306A — SKR3310A — SKR3320A — SKR4610A — SKR4620A

Unit: kg

	0.15 G	0.3 G	0.5 G	1 G	1.5 G	2 G
SKR3306A	19	19	19	18	10	4.5
SKR3310A	12	12	12	12	9	6
SKR3320A	6	6	6	5.5	5	4
SKR4610A	23	23	23	23	23	20.5
SKR4620A	18	18	18	18	18	15.5

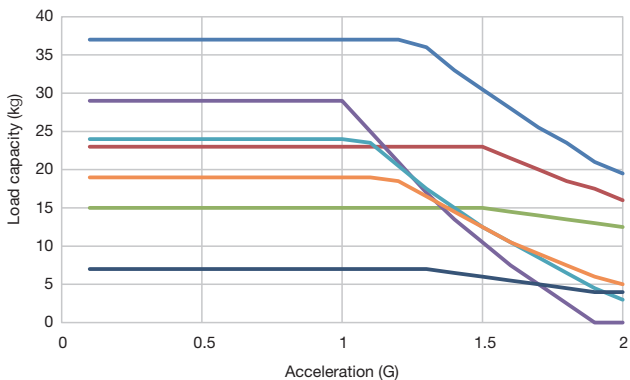

— SKR5520A — SKR5530A — SKR5540A — SKR6520A — SKR6525A — SKR6530A — SKR6550A

Unit: kg

	0.15 G	0.3 G	0.5 G	1 G	1.5 G	2 G
SKR5520A	37	37	37	37	30.5	19.5
SKR5530A	23	23	23	23	23	16
SKR5540A	15	15	15	15	15	12.5
SKR6520A	29	29	29	29	10.5	-
SKR6525A	24	24	24	24	12.5	3
SKR6530A	19	19	19	19	12.5	5
SKR6550A	7	7	7	7	6	4

Calculation Conditions

Model	Lead (mm)	Stroke* (mm)	Estimated motor capacity (W)	Speed (mm/s)	Center of gravity
SKR20	1	80	50	50	Center of table upper surface
	6			300	
SKR26	2	160	50	100	
	6			300	
SKR33	6	395	100	300	
	10			500	
	20			1,000	
SKR46	10	490	400	500	
	20			1,000	
SKR55	20	1,000	750	1,000	
	30			1,500	
	40			2,000	
SKR65	20	1,190	750	1,000	
	25			1,250	
	30			1,500	
	50			2,500	

* Stroke with 1 block (A type).

Load Rating and Static Permissible Moment for Each Direction

Load Rating

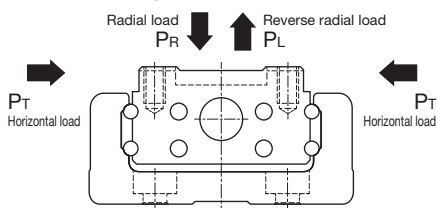

SKR: 4-way loads

- **LM Guide**
The SKR can receive loads in 4 directions (radial, reverse radial, and horizontal directions). The basic load rating is when each of the 4 directions is equal. These values are listed in the "Load Rating" table below.
- **Ball screw**
The SKR has a ball screw nut built into the inner block to enable axial loads to be applied. The basic load rating is listed in the "Load Rating" table below.
- **Bearing (fixed side)**
The SKR's housing A has an embedded angular bearing to enable axial loads to be applied. The basic load rating is listed in the "Load Rating" table below.

Equivalent Load (LM Guide)

The equivalent load when the LM Guide unit of the Model SKR simultaneously receives loads in all directions is obtained from the following formula.

$$P_E = P_R(P_L) + P_T$$

P_E : Equivalent load (N)
 P_R : Radial load (N)

P_L : Reverse radial load (N)
 P_T : Horizontal load (N)

Load Rating

Model			SKR20		SKR26		SKR33 ¹			SKR46 ¹		SKR55			SKR65																			
			SKR2001	SKR2006	SKR2602	SKR2606	SKR3306	SKR3310	SKR3320	SKR4610	SKR4620	SKR5520	SKR5530	SKR5540	SKR6520	SKR6525	SKR6530	SKR6550																
LM Guide	Basic dynamic load rating $C(N)$	1 block (A type)	6,010		13,000		17,000			39,500		55,400			74,400																			
		1 short block (C type)	-		-		11,300		-	28,400		-			-																			
	Basic static load rating $C_0(N)$	1 block (A type)	8,030		16,500		20,400			45,900		62,500			81,600																			
		1 short block (C type)	-		-		11,500		-	28,700		-			-																			
Ball screw	Ball screw lead (mm)		1	6	2	6	6	10	20	10	20	20	30	40	20	25	30	50																
	Basic dynamic load rating $C_a(N)$	Normal grade/High accuracy grade (H)	660		860		2,350		1,950		4,400		2,700		2,620		4,350		4,240		10,900		7,000		6,800		12,100		12,000		8,200		7,600	
		Precision grade (P)	-		1,060		2,390		-		-		-		-		-		-		-		-		-		-		-		-			
	Basic static load rating $C_{0a}(N)$	Normal grade/High accuracy grade (H)	1,170		1,450		3,510		6,290		3,780		3,770		6,990		7,040		17,600		11,500		9,900		21,600		22,000		14,500		12,600			
Precision grade (P)		-		1,600		3,900		-		-		-		-		-		-		-		-		-		-		-		-				
Bearing (Fixed side)	Axial direction	Basic dynamic load rating $C_a(N)$	1,150		2,000		6,250			6,700		7,600			13,700																			
		Static permissible load $P_{0a}(N)$	735		1,230		2,700			3,330		3,990			5,830																			

¹ Customized products can also be made to handle special environments or large axial loads (25% or more of the basic dynamic load rating C_a). Consult with THK.

Notes: 1. The LM Guide load rating is the load rating per block.
2. SKR3320 does not have short blocks.

Static Permissible Moment (LM Guide)

The SKR LM Guide supports moment loads in 3 directions with a single block.

A: 1 block (A type)

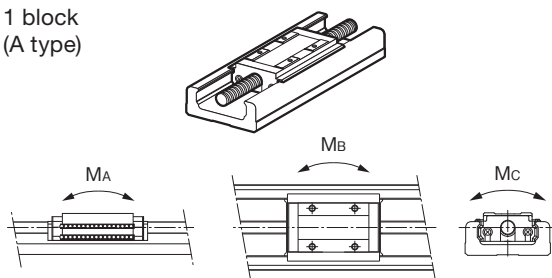

C: 1 short block (C type)

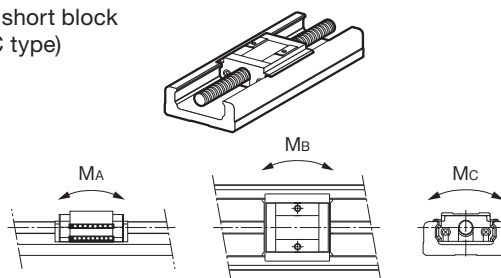

B: 2 blocks (B type)

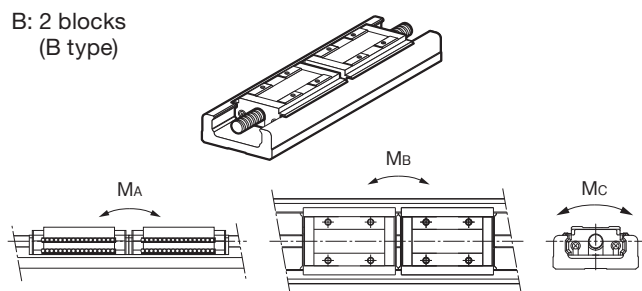

D: 2 short blocks (D type)

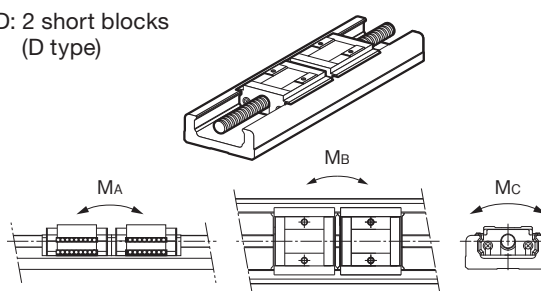

Static Permissible Moment

The static permissible moment values are for the LM Guide.

Unit: N·m

Model	Static permissible moment		
	M _A	M _B	M _C
SKR20-A	38	38	98
SKR20-B	207	207	197
SKR26-A	117	117	265
SKR26-B	589	589	530
SKR33-A	173	173	424
SKR33-B	990	990	848
SKR33-C	58	58	240
SKR33-D	390	390	480
SKR46-A	579	579	1,390
SKR46-B	3,240	3,240	2,780
SKR46-C	236	236	870
SKR46-D	1,460	1,460	1,740
SKR55-A	923	923	2,276
SKR55-B	5,125	5,125	4,552
SKR65-A	1,366	1,366	3,868
SKR65-B	7,702	7,702	7,736

Notes: 1. The "A," "B," "C," or "D" at the end of the model number indicates the block type.

A: 1 block / B: 2 blocks / C: 1 short block / D: 2 short blocks

2. The value for SKR-B/D is with 2 blocks attached (without QZ).

3. Static permissible moment is the maximum permissible moment when the unit is stationary.

Permissible Moment

This is the moment that can be tolerated when stationary, taking the inner block and sub-table's connectors into consideration.

Unit: N·m

Model	Permissible moment		
	M _A	M _B	M _C
SKR20-A	14 (9)	7 (8)	13 (13)
SKR20-B	67 (39)	27 (32)	26 (27)
SKR26-A	35 (31)	18 (17)	29 (30)
SKR26-B	151 (154)	67 (47)	59 (60)
SKR33-A	51 (38)	33 (34)	51 (51)
SKR33-B	261 (172)	130 (93)	103 (103)
SKR33-C	24 (8)	11 (14)	25 (17)
SKR33-D	86 (55)	46 (38)	51 (51)
SKR46-A	105 (34)	72 (68)	105 (34)
SKR46-B	504 (162)	268 (188)	211 (68)
SKR46-C	55 (17)	25 (30)	52 (17)
SKR46-D	176 (56)	99 (78)	105 (34)
SKR55-A	170 (169)	141 (212)	170 (169)
SKR55-B	872 (863)	553 (686)	341 (338)
SKR65-A	349 (170)	306 (316)	349 (326)
SKR65-B	1,441 (988)	1,015 (845)	698 (653)

Notes: 4. The "A," "B," "C," or "D" at the end of the model number indicates the block type.

A: 1 block / B: 2 blocks / C: 1 short block / D: 2 short blocks

5. The value for KR-B/D is with 2 blocks attached (without QZ).

6. Values in parentheses are with a cover or bellows.

Service Life

The SKR is composed of an LM Guide, ball screw, and support bearing. The service life of each structure can be calculated using the basic dynamic load rating described in the "Load Rating" table on p. 115.

LM Guide

Nominal Life

$$L_{10} = \left(\frac{C}{P_C} \right)^3 \times 50$$

L_{10} : Nominal life (km)

(The nominal life is the total travel distance that 90% of a group of LM Guide units can achieve without flaking after individually running under the same conditions.)

C: Basic dynamic load rating (N)

P_C : Calculated load (N)

- If a moment will be applied, multiply the applied moment by the equivalent factor listed in the "Equivalent Moment Factors (K)" table on p. 118 to calculate the equivalent load.

$$P_m = K \cdot M$$

P_m : Equivalent load (per block) (N)

K: Equivalent moment factor (see the "Equivalent Moment Factors (K)" table)

M: Applied moment (N·mm)

(If planning to use the product with a wide block span, contact THK.)

- If moment M_c is applied with SKR-B/D

$$P_m = \frac{K_c \cdot M_c}{2}$$

- If a radial load (P) and a moment are simultaneously applied to the KR

$$P_E = P_m + P$$

P_E : Total equivalent radial load (N)

Perform a nominal life calculation using the above data.

Service Life Time

$$L_h = \frac{L_{10} \times 10^6}{2 \cdot \ell_s \cdot n_1 \times 60}$$

Once the nominal life (L_{10}) has been obtained, the service life time can be obtained using the following formula if the stroke length and the cycles per minute are constant.

L_h : Service life time (h)

ℓ_s : Stroke length (mm)

n_1 : Cycles per minute (min^{-1})

Ball Screw and Bearing Unit (Fixed Side)

Nominal Life

$$L_{10} = \left(\frac{C_a}{F_a} \right)^3 \times 10^6$$

L_{10} : Nominal life (rev.)

(The nominal life is the total rotations that 90% of a group of ball screw (bearing) units can achieve without flaking after individually running under the same conditions.)

C_a : Basic dynamic load rating (N)

F_a : Axial load (N)

Service Life Time

$$L_h = \frac{L_{10} \cdot \ell}{2 \cdot \ell_s \cdot n_1 \times 60}$$

Once the nominal life (L_{10}) has been obtained, the service life time can be obtained using the following formula if the stroke length and the cycles per minute are constant.

L_h : Service life time (h)

ℓ_s : Stroke length (mm)

n_1 : Cycles per minute (min^{-1})

ℓ : Ball screw lead (mm)

f_c : Contact Factor

When using 2 blocks with SKR-B/D, multiply the basic load rating by the contact factor from the table on the right.

Contact Factors (f_c)

Block type	Contact factor (f_c)
SKR-B	0.81
SKR-D	

f_w : Load Factor

In general, reciprocating machines tend to experience vibrations or impacts during operation, and it is difficult to accurately determine the vibrations generated during high-speed operation and impacts during frequent starts and stops. Therefore, when speed and impacts have a significant influence, divide the basic dynamic load rating (C) by the corresponding load factor, which has been empirically obtained.

Load Factor (f_w)

Vibrations/impacts	Speed (V)	Load coefficient (f_w)
Very low	Under very low speeds $V \leq 0.25$ m/s	1 to 1.2
Low	Under low speeds 0.25 m/s $< V \leq 1$ m/s	1.2 to 1.5
Medium	Under medium speeds 1 m/s $< V \leq 2$ m/s	1.5 to 2
High	Under high speeds $V > 2$ m/s	2 to 3.5

K: Equivalent Moment Factor (LM Guide)

When running while bearing a load, multiply the equivalent moment factor shown in the table below by the moment value to calculate the load, because the load distribution of the LM Guide will be greater locally. K_A , K_B , and K_C show the equivalent moment factors for directions M_A , M_B , and M_C .

Equivalent Moment Factors (K)

Model	K_A	K_B	K_C
SKR20-A	2.34×10^{-1}	2.34×10^{-1}	8.07×10^{-2}
SKR20-B	4.38×10^{-2}	4.38×10^{-2}	8.07×10^{-2}
SKR26-A	1.59×10^{-1}	1.59×10^{-1}	6.17×10^{-2}
SKR26-B	3.18×10^{-2}	3.18×10^{-2}	6.17×10^{-2}
SKR33-A	1.42×10^{-1}	1.42×10^{-1}	5.05×10^{-2}
SKR33-B	2.47×10^{-2}	2.47×10^{-2}	5.05×10^{-2}
SKR33-C	2.39×10^{-1}	2.39×10^{-1}	5.05×10^{-2}
SKR33-D	3.54×10^{-2}	3.54×10^{-2}	5.05×10^{-2}
SKR46-A	9.51×10^{-2}	9.51×10^{-2}	3.46×10^{-2}
SKR46-B	1.70×10^{-2}	1.70×10^{-2}	3.46×10^{-2}
SKR46-C	1.46×10^{-1}	1.46×10^{-1}	3.46×10^{-2}
SKR46-D	2.36×10^{-2}	2.36×10^{-2}	3.46×10^{-2}
SKR55-A	8.12×10^{-2}	8.12×10^{-2}	2.88×10^{-2}
SKR55-B	1.46×10^{-2}	1.46×10^{-2}	2.88×10^{-2}
SKR65-A	7.16×10^{-2}	7.16×10^{-2}	2.21×10^{-2}
SKR65-B	1.27×10^{-2}	1.27×10^{-2}	2.21×10^{-2}

K_A : Equivalent moment factor in the M_A direction.

K_B : Equivalent moment factor in the M_B direction.

K_C : Equivalent moment factor in the M_C direction.

Note: The value for SKR-B/D is with 2 blocks attached.

Accuracy Standards

Positioning Repeatability

A positioning operation is performed to arrive at a given arbitrary point, the stop position is measured, and the operation is repeated seven times from the same direction to determine half the difference between the largest and smallest values. The same test is conducted at three points: the middle of the stroke and both the approximate maximum and minimum positions of travel. The positioning repeatability is expressed as the maximum difference among the three measurements divided by 2 with a "±" sign.

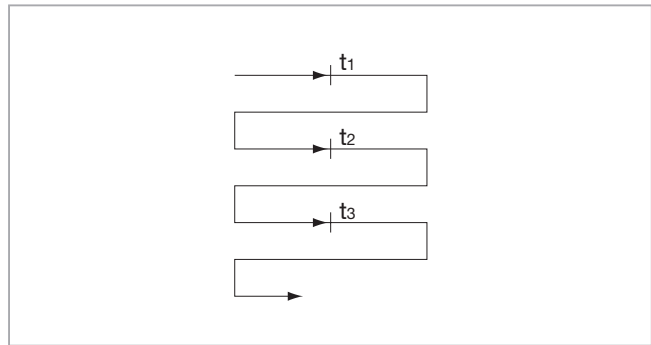

Positioning Accuracy

With the maximum stroke as reference length, the maximum error between the command value and the actual travel distance from the stroke start position is displayed as an absolute value.

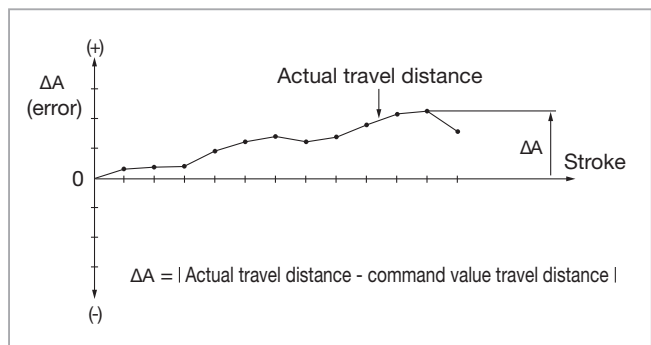

Running Parallelism (Vertical Direction)

A straightedge is positioned on a surface plate with the SKR mounted and the entire range of block movement is measured with a test indicator, taking the maximum difference in readings along the travel distance as the measured value.

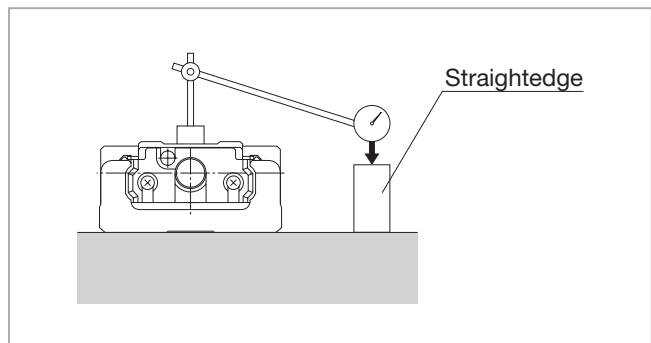

Backlash

Using as a reference the test indicator reading with feeding applied to the block to move it slightly, a load is applied to the block from the same direction (table feed direction) in this state, without using the feed mechanism, and then the difference between the reference when opened and the return value is taken as the measured value. This measurement is made at the center of the travel distance and at each of the two ends; the largest of the obtained values is set as the measurement value.

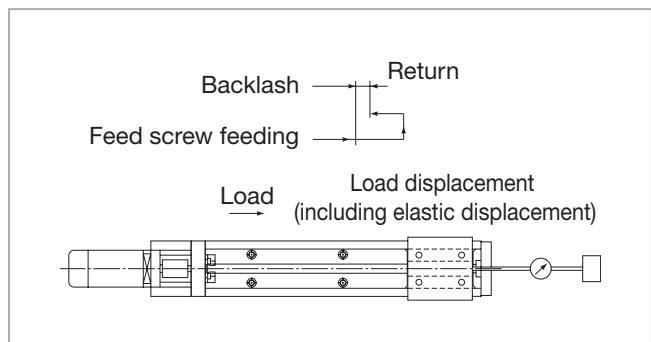

Normal Grade (No Symbol)

Unit: mm

Model	Stroke ¹	Outer rail length	Positioning repeatability	Positioning accuracy	Running parallelism (vertical direction)	Backlash	Starting torque (N-cm)
SKR20	30	100	±0.01	Not specified	Not specified	0.02	0.5
	80	150					
	130	200					
SKR26	60	150	±0.01	Not specified	Not specified	0.02	1.5
	110	200					
	160	250					
SKR33	210	300	±0.01	Not specified	Not specified	0.02	7
	45	150					
	95	200					
	195	300					
	295	400					
	395	500					
SKR46	495	600	±0.01	Not specified	Not specified	0.02	10
	595	700					
	190	340					
	290	440					
	390	540					
	490	640					
SKR55	590	740	±0.01	Not specified	Not specified	0.05	12
	690	840					
	790	940					
	800	980					
	900	1,080					
	1,000	1,180					
SKR65	1,100	1,280	±0.01	Not specified	Not specified	0.05	12
	1,200	1,380					
	790	980					
	1,490	1,680					

High Accuracy Grade (H)

Unit: mm

Model	Stroke ¹	Outer rail length	Positioning repeatability	Positioning accuracy	Running parallelism (vertical direction)	Backlash	Starting torque (N-cm)
SKR20	30	100	±0.005	0.06	0.025	0.01	0.5
	80	150					
	130	200					
SKR26	60	150	±0.005	0.06	0.025	0.01	1.5
	110	200					
	160	250					
SKR33	210	300	±0.005	0.06	0.025	0.02	7
	45	150					
	95	200					
	195	300					
	295	400					
	395	500					
SKR46	495	600	±0.005	0.1	0.035	0.02	10
	595	700					
	190	340					
	290	440					
	390	540					
	490	640					
SKR55	590	740	±0.005	0.12	0.04	0.05	12
	690	840					
	790	940					
	800	980					
	900	1,080					
	1,000	1,180					
SKR65	1,100	1,280	±0.005	0.18	0.05	0.05	12
	1,200	1,380					
	790	980					
	1,490	1,680					

Precision Grade (P)

Unit: mm

Model	Stroke ¹	Outer rail length	Positioning repeatability	Positioning accuracy	Running parallelism (vertical direction)	Backlash	Starting torque (N-cm)
SKR20	30	100	±0.003	0.02	0.01	0.003	1.2
	80	150					
	130	200					
SKR26	60	150	±0.003	0.02	0.01	0.003	4
	110	200					
	160	250					
SKR33	210	300	±0.003	0.02	0.01	0.003	15
	45	150					
	95	200					
	195	300					
	295	400					
	395	500					
SKR46	495	600	±0.003	0.025	0.015	0.003	15
	595	700					
	190	340					
	290	440					
	390	540					
	490	640					
SKR55	590	740	±0.005	0.03	0.02	0.003	17
	690	840					
	790	940					
	800	980					
	900	1,080					
	1,000	1,180					
SKR65	1,100	1,280	±0.005	0.035	0.03	0.005	20
	1,200	1,380					
	790	980					
	1,490	1,680					

¹ Stroke with 1 block (A type: Without QZ).

Notes: 1. Accuracy standard evaluation method in accordance with THK standards.

2. Measured using a motor for inspection. With motor wrap specifications, measurements are not made in the completed motor wrap state.

3. The starting torque represents the value when the following grease is used.

Models SKR20 and SKR26: THK AFA Grease

Models SKR33, SKR46, SKR55 and SKR65: THK AFB-LF Grease

4. The starting torque may exceed standards if using vacuum grease, clean room grease, or other high-viscosity greases, so care should be taken when selecting a motor.

5. Contact THK for accuracy higher than the standard outer rail length.

Seals

End seals and side seals are attached as standard for dust-proofing.

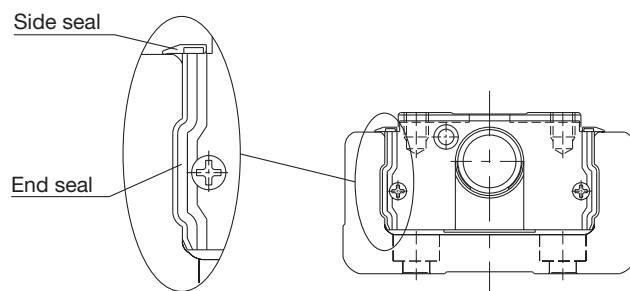

Maximum Resistance Value

The following table shows the maximum resistance values for each model.

Units: N

Model	Maximum resistance value
SKR20	4.8
SKR26	5.7
SKR33	4.7
SKR46	8.1
SKR55	17.8
SKR65	24.1

Standard Grease

The following table shows the standard grease and grease nipple used.

Model	Standard grease	Grease nipple used
SKR20	THK AFA Grease	PB107
SKR26	THK AFA Grease	PB107
SKR33	THK AFB-LF Grease	PB107
SKR46	THK AFB-LF Grease	A-M6F
SKR55	THK AFB-LF Grease	A-M6F
SKR65	THK AFB-LF Grease	A-M6F

Precautions on Use

How to Use this Product

- This product must not be used for devices or systems that are utilized under situations that may affect human life.
- Be sure to contact THK in advance if you are considering using this product for special applications, such as with devices or systems relating to passenger vehicles, medicine, aerospace, nuclear power, or electric power.

Products with Rotary Motor Drives

Handling

- Please contact THK when using the product in special environments such as locations exposed to constant vibrations, clean rooms, vacuums, and low/high temperatures.
- Tilting the table or the outer rail may cause them to fall due to their own weight.

Safety Precautions

- Carefully read JIS B8433 "Manipulating Industrial Robots - Safety" and the Japanese Ministry of Health, Labour and Welfare's "Ordinance on Industrial Safety and Health" before working with the product, and follow the guidance within.
- Carefully read the user manual, gain a sufficient understanding of its contents, and be sure to follow the safety precautions.
- When installing, adjusting, inspecting, or performing maintenance on the main actuator unit and connected peripherals, be sure to remove all power plugs from their outlets, and prepare a lock or safety plug to prevent anyone else from turning on the power. Additionally, place a sign in a visible location to notify others that work is being performed.
- Do not touch any moving parts of the actuator while it is energized. In addition, do not enter the operating range of this product while it is in operation or in an operable state.
- If performing a task involving multiple people, confirm how to perform the work, what signals will be used, and how to handle problems before beginning, and assign another person to monitor the work.
- Do not carelessly disassemble this product. Otherwise, it may cause foreign material ingress or decrease the accuracy.
- Take care not to drop or strike this product. Otherwise, it may cause injury or damage the unit. Even if there is no outward indication of damage, a sudden impact could prevent the unit from functioning properly.
- Using this product in excess of the permissible rotational speed may damage the components or cause an accident. Be sure to use the product within the specified rotational speed designated by THK.
- Prevent foreign materials such as cutting chips from entering the product. Otherwise, it may damage the ball circulation components or result in a loss of functionality.
- If using the product in an environment where coolant may get inside, contact THK.
- Install shock absorbers or another impact-absorbing mechanism if there is a risk that the slider may strike the stoppers mounted on both ends of the range of motion. The stoppers are not intended to absorb the impact from sliders. Impacts to the stoppers during operation may lead to damage or accidents.
- Using this product in excess of the torque limit may damage the components or cause an accident.
- Do not set the torque control parameter higher than the torque limit.
- The motor wrap type does not have a safety device for if the timing belt breaks. For your safety, please install a safety device next to the equipment.
- Some models of this product are heavy, with the main unit of this product weighing in excess of 20 kg. Use appropriate transportation equipment and take safety precautions to avoid injury or damage when transporting or installing the product.
- In applications where this product will be moved or transferred, the conditions of use may cause inertia from the motor's mass to result in damage to the motor attachment (Housing A) or other parts. Please contact THK before use.

Operating Environment

- Indoors, ambient temperature between 0°C to 40°C, and ambient humidity of 80% RH or less (no freezing or condensation)
- A location with no corrosive or flammable gas
- A location where vibrations or impacts are not transmitted to the main unit
- A location where electrically conductive particles such as steel dust, dust, oil mist, cutting oil, water content, salt content, or organic solvents will not be present in the air
- A location not exposed to direct sunlight or radiant heat
- A location where no strong electric fields or powerful magnetic fields are generated
- A location where inspections and cleanings can easily be performed
- When using the product in locations exposed to constant vibrations or in special environments such as in vacuums or low/high temperatures, contact THK.

Actuator Mounting Surface

- Prepare a flat surface that has been machined or possesses an equivalent level of accuracy. Some products have required degrees of flatness.
- Be sure to mount the product on a sufficiently rigid base.

Lubrication

- The actuator must be lubricated in order for it to demonstrate its full performance. Insufficient lubrication may increase wear on the rolling elements and lead to premature damage.
- Do not mix lubricants with different properties. Please be aware that the applied lubricant will differ depending on the product.
- Contact THK if a special lubricant will be used.
- As a general guideline, the greasing interval should be every 100 km. However, this will vary depending on the operating conditions, so we recommend determining the greasing interval based on the initial inspection.
- Contact THK if the product will be used in a special environment such as a location with constant vibrations, a vacuum, high/low temperatures, or a clean room, as it may not be possible to use the regular lubricant.
- Contact THK if oil lubricant will be used.
- Thoroughly wipe off anti-rust oil and feed lubricant before using the product.

Storage

- When storing the actuator, enclose it in a package designated by THK and store it in a horizontal orientation while avoiding high temperatures, low temperatures, and high humidity.
- Avoid storing control devices in an environment with high/low temperatures or high humidity.

Disposal

- The product should be treated as industrial waste and disposed of appropriately.

Other Recommended Products

LM Guide Actuator

KR

- Modularized structure reduces number of components and both design and assembly time
- Can be used in various orientations, including horizontal, wall-mounted, vertical, and hanging
- Extensive lineup of 9 sizes



LM Guide Actuator with Large-Diameter Ball Screw

KSF

Open Cover/Top Cover/Fully Enclosed

- Large-diameter ball screw enables high-speed and high-acceleration operations
- 3 types of cover options to choose from to suit the application
- Supports long strokes up to 1,500 mm

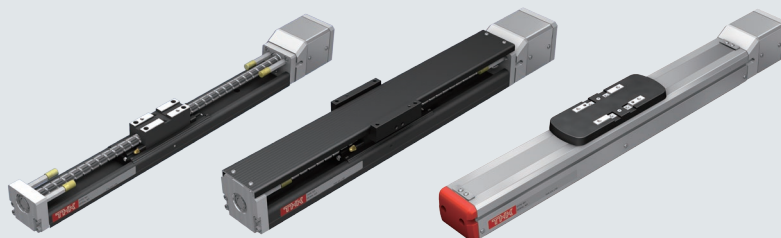

Caged Ball LM Guide Actuator SKR

- **LM Guide and Caged Ball**  are registered trademarks of THK CO., LTD.
- The actual products may differ from the illustrations and photographs in this catalog.
- Outward appearances and specifications are subject to change without notice for the purpose of improvement. Please consult with THK before using.
- Although great care has been taken in the production of this catalog, THK will not take any responsibility for damages resulting from typographical errors or omissions.
- For exports of our products and technologies and sales for export, our basic policy is to comply with the Foreign Exchange and Foreign Trade Act and other laws and regulations. Please consult us in advance if you want to export our products by the piece.

All rights reserved.

THK CO., LTD.

Global Headquarters 2-12-10 Shibaura, Minato-ku, Tokyo 108-8506 Japan

International Sales Department Phone: +81-3-5730-3860

www.thk.com