



Slide Pack

THK General Catalog

A Product Descriptions

Features and Types	A12-2
Features of the Slide Pack	A12-2
• Structure and Features	A12-2
Types of Slide Pack	A12-3
• Types	A12-3
• Clearance	A12-3
Dimensional Drawing, Dimensional Table	
Model FBW2560XR	A12-4
Model FBW3590XR	A12-5
Model FBW50110XR	A12-6
Design Highlights	A12-7
Installation	A12-7
Lubrication	A12-8
Example Applications	A12-8
Options	A12-9
Contamination Protection	A12-9
Metal Dust Cover	A12-9
Jointed Slide Rails	A12-10
Model No.	A12-11
• Model Number Coding	A12-11
Handling Precautions	A12-12

B Support Book (Separate)

Features and Types	B12-2
Features of the Slide Pack	B12-2
• Structure and Features	B12-2
Types of Slide Pack	B12-3
• Types	B12-3
Mounting Procedure and Maintenance ..	B12-4
Installation	B12-4
Lubrication	B12-5
Example Applications	B12-5
Model No.	B12-6
• Model Number Coding	B12-6
Handling Precautions	B12-7

Features of the Slide Pack

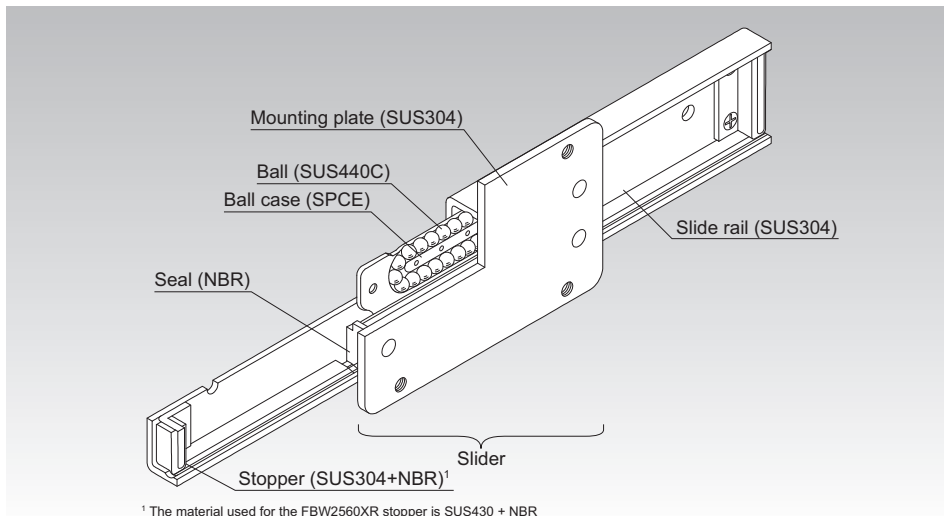

Fig. 1: Structure of Slide Pack Model FBW-XRUU

Structure and Features

Slide Pack Model FBW-XR is an LM System in which a precision-press-molded slider that contains balls performs infinite linear motion. Used in combination with a slide rail, the slide pack achieves lightweight and compact design and smooth linear motion.

This product is optimal for light-load slide units in products such as photocopiers, tool cabinets, electronic equipment cabinets, automatic vending machines, machine tool slide covers, cash registers, and curtain walls.

High Corrosion Resistance

Austenitic stainless steel is used in components such as rails, mounting plates, and stoppers to ensure excellent corrosion resistance.

Low Noise

The slider unit in the FBW2560XR, FBW3590XR, and 50110XR has been redesigned to provide noise levels 5 dBA lower than the previous models (at a speed of 60 m/min. in the FBW3590XR).

Types of Slide Pack

Types

Model FBW 2560XR

Dimensional Table⇒ **A 12-4**

This model is a compact type.

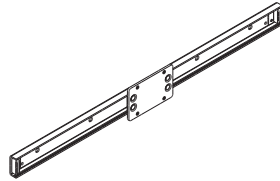

Model FBW 3590XR

Dimensional Table⇒ **A 12-5**

This model is the standard type.

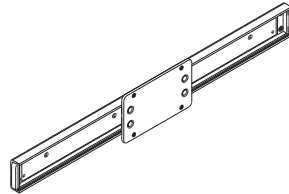

Model FBW 50110XR

Dimensional Table⇒ **A 12-6**

This model is a heavy-load type.

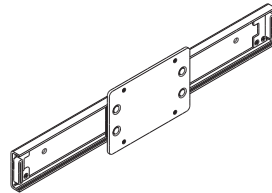

Clearance

Model FBW-XR is manufactured to the following specifications.

Vertical clearance: 0.03 mm or less

Horizontal clearance: 0.1 mm or less

These specifications are values when the slide rail is attached to a rigid base.

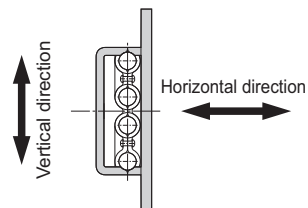
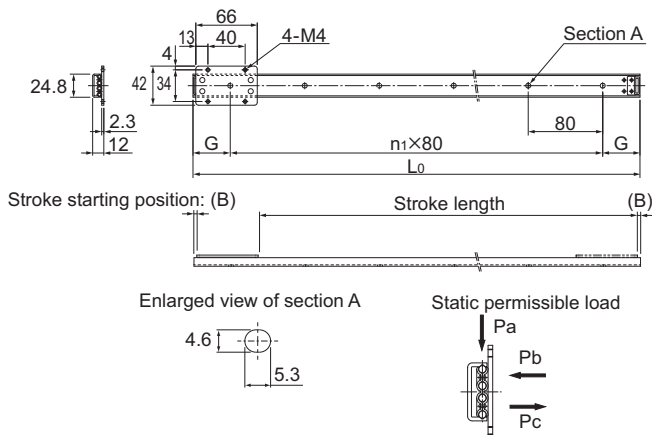

Fig. 2

Model FBW2560XR



Unit: mm

Slide rail length L_0	Main dimensions		Without seal		With seal		Static permissible load N			Slide rail mass g
	n_1	G	B	Stroke length	B	Stroke length	P_a	P_b	P_c	
160	1	40	3	88	5.5	83	590	150	70	70
240	2	40	3	168	5.5	163	590	150	70	110
320	3	40	3	248	5.5	243	590	150	70	140
400	4	40	3	328	5.5	323	590	150	70	180
480	5	40	3	408	5.5	403	590	150	70	210
560	6	40	3	488	5.5	483	590	150	70	250
640	7	40	3	568	5.5	563	590	150	70	290
720	8	40	3	648	5.5	643	590	150	70	320
800	9	40	3	728	5.5	723	590	150	70	360
880	10	40	3	808	5.5	803	590	150	70	390
960	11	40	3	888	5.5	883	590	150	70	430
1040	12	40	3	968	5.5	963	590	150	70	460
1200	14	40	3	1128	5.5	1123	590	150	70	540

Notes: The FBW2560XR slider mass is 70 g.

This model is also available with a dust cover, see [A12-9](#).

Lithium soap-based grease No. 2 is applied to the slider and ball circulation components.

Model number coding

2 FBW2560XR UU +800L - T

Model No.

No. of sliders connected
on the same rail
(no symbol for a single slider)

Overall slide rail length
(mm)Jointed slide rails symbol¹

With seal
(no symbol for products without a seal)

¹ For jointed slide rails, see [A12-10](#).

Model FBW3590XR

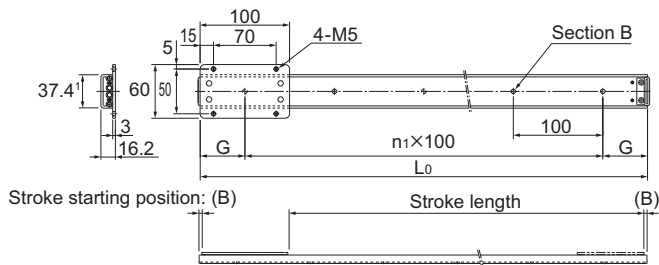

Enlarged view of rail end

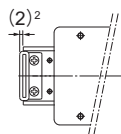

Enlarged view of section B

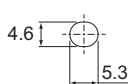

Static permissible load

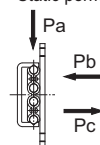

Unit: mm

Slide rail length L_0	Main dimensions		Without seal		With seal		Static permissible load N			Slide rail mass g
	n_1	G	B	Stroke length	B	Stroke length	P_a	P_b	P_c	
300	2	50	0	200	2.5	195	880	200	100	280
350	3	25	0	250	2.5	245	880	200	100	330
400	3	50	0	300	2.5	295	880	200	100	380
450	4	25	0	350	2.5	345	880	200	100	420
500	4	50	0	400	2.5	395	880	200	100	470
550	5	25	0	450	2.5	445	880	200	100	520
600	5	50	0	500	2.5	495	880	200	100	560
650	6	25	0	550	2.5	545	880	200	100	610
700	6	50	0	600	2.5	595	880	200	100	650
750	7	25	0	650	2.5	645	880	200	100	710
800	7	50	0	700	2.5	695	880	200	100	750
900	8	50	0	800	2.5	795	880	200	100	850
1000	9	50	0	900	2.5	895	880	200	100	930
1200	11	50	0	1100	2.5	1095	880	200	100	1090
1500	14	50	0	1400	2.5	1395	880	200	100	1410
1800	17	50	0	1700	2.5	1695	880	200	100	1740

¹ The rail is 0.4 mm wider than the previous model (FBW3590R).

² For Model FBW3590XR, the stopper protrudes past the end of the slide rail.

Notes: The FBW3590XR slider mass is 250 g.

This model is also available with a dust cover, see **A12-9**.

Lithium soap-based grease No. 2 is applied to the slider and ball circulation components.

Model number coding

2 FBW3590XR UU +800L - T

Model No.

No. of sliders connected on the same rail
(no symbol for a single slider)

Overall slide rail length
(mm)

Jointed slide rails symbol¹

With seal
(no symbol for products without a seal)

¹ For jointed slide rails, see **A12-10**.

Model FBW50110XR

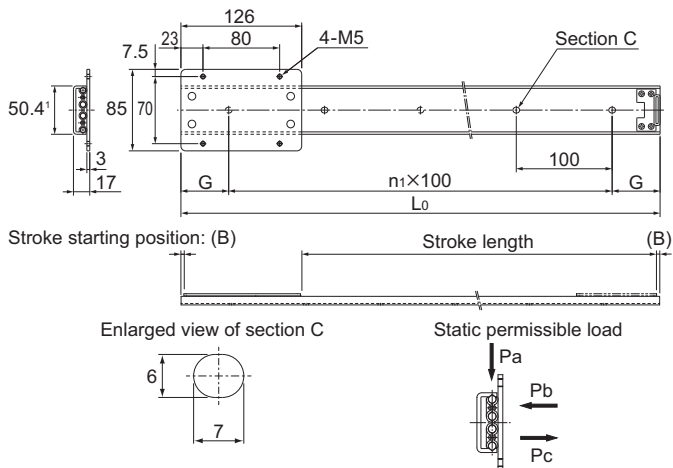

Unit: mm

Slide rail length L_0	Main dimensions		Without seal		With seal		Static permissible load N			Slide rail mass g
	n_1	G	B	Stroke length	B	Stroke length	P_a	P_b	P_c	
300	2	50	2	170	5	164	1960	500	390	390
350	3	25	2	220	5	214	1960	500	390	460
400	3	50	2	270	5	264	1960	500	390	520
450	4	25	2	320	5	314	1960	500	390	590
500	4	50	2	370	5	364	1960	500	390	650
600	5	50	2	470	5	464	1960	500	390	780
700	6	50	2	570	5	564	1960	500	390	910
800	7	50	2	670	5	664	1960	500	390	1040
900	8	50	2	770	5	764	1960	500	390	1190
1000	9	50	2	870	5	864	1960	500	390	1300
1200	11	50	2	1070	5	1064	1960	500	390	1520
1500	14	50	2	1370	5	1364	1960	500	390	1950
1800	17	50	2	1670	5	1664	1960	500	390	2380

¹ The rail is 0.4 mm wider than the previous model (FBW50110R).

Notes: The FBW50110XR slider mass is 420 g.

This model is also available with a dust cover, see **A12-9**.

Lithium soap-based grease No. 2 is applied to the slider and ball circulation components.

Model number coding

2 FBW50110XR UU +800L - T

Model number

No. of sliders connected on the same rail
(no symbol for a single slider)

Overall slide rail length
(mm)

Jointed slide rails symbol¹

With seal

(no symbol for products without a seal)

¹ For jointed slide rails, see **A12-10**.

Installation

Slide Rail Mounting Screws

Since the space for securing the slide rail mounting screws is small, as shown in Fig. 1, we recommend using button head bolts or binding head bolts (JIS B 1111 annex).

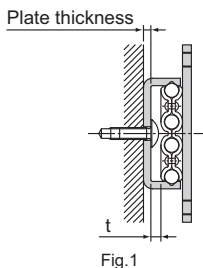

Unit: mm

Model No.	Mounting screw size	Rail plate thickness	t
FBW 2560XR	M4	1.5	3.2
FBW 3590XR	M4	2.5	3.4
FBW 50110XR	M5	2.5	3.4

Attaching a Stopper

If the slider may overshoot and come off of the slide rail, attach a dedicated stopper to the slide rail end as shown in Fig. 2.



Fig. 2

Installing the Slider

With Model FBW-XR, balls will not fall off even if the slider is removed from the slide rail. However, they could fall if the slider is twisted when reattaching it to the slide rail. Whenever possible, do not remove the slider from the slide rail when installing the slide pack.

Groove Dimensions

The groove dimensions when Model FBW-XR is installed in a groove are shown in Fig. 3.

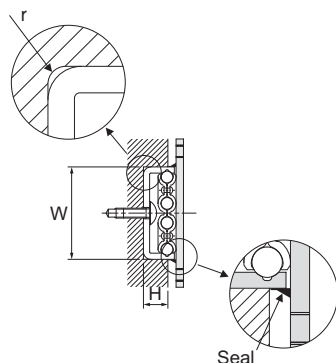

Fig. 3

Unit: mm

Model No.	W	H	r (max)
FBW 2560XR	24.8 $+0.15$ $+0.1$	7.4	1
FBW 3590XR	37.4 $+0.15$ $+0.1$	10	2
FBW 50110XR	50.4 $+0.15$ $+0.1$	10	2.5

Note: The groove width for the FBW3590XR and 50110XR is 0.4 mm more than for the previous models (3590R and 50110R).

Lubrication

High-quality lithium soap-based grease is applied to the slide and ball circulation areas.

Example Applications

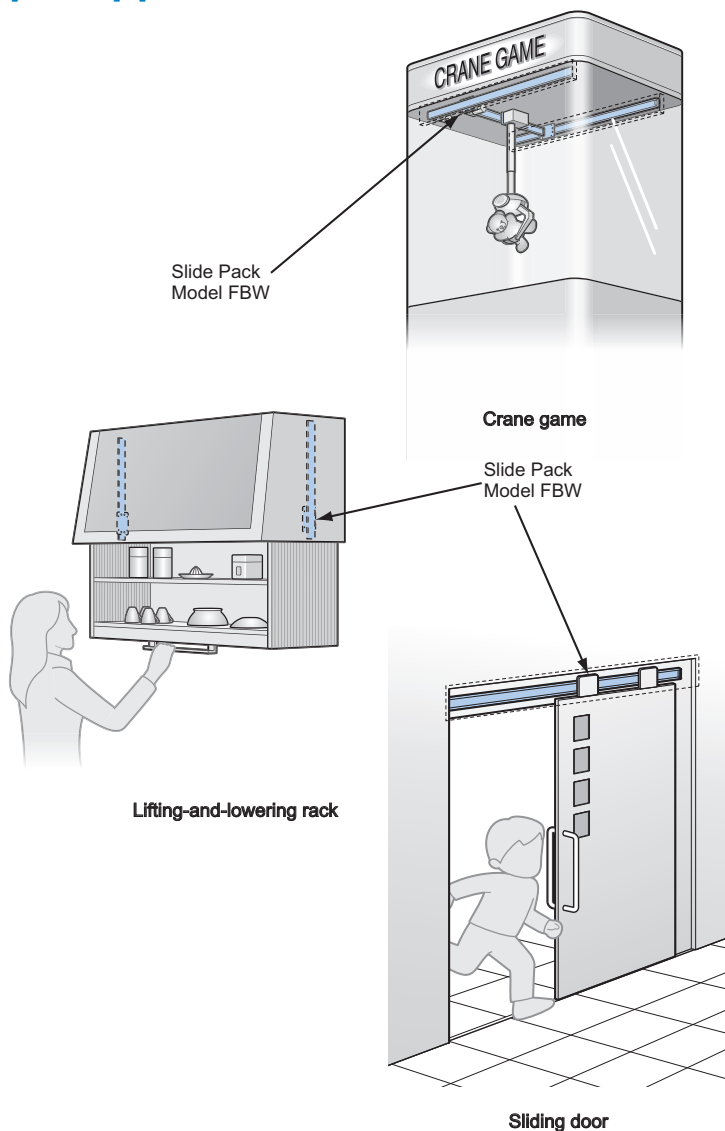

Contamination Protection

A special synthetic rubber seal with high contamination protection characteristics, capable of preventing foreign material from entering the slider and the lubricant from leaking, is available for Slide Pack Model FBW-XR. The seal increases the contamination protection effect by contacting both the slide rail raceway where balls roll and the slide rail itself.



Metal Dust Cover

Stainless steel (SUS304) covers that fit over the whole slide rail and prevent foreign material from entering the slide are available for Slide Pack Model FBW-XR.

Model FBW2560XRG

(Equipped with a contamination protection cover)

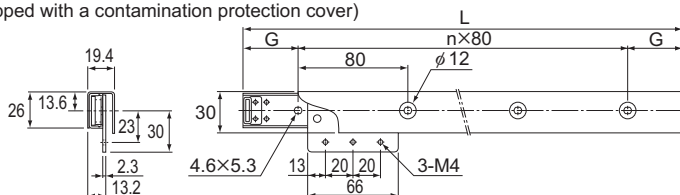

Model FBW3590XRG

(Equipped with a contamination protection cover)

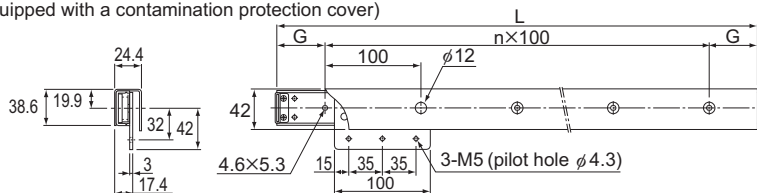

Model FBW50110XRG

(Equipped with a contamination protection cover)

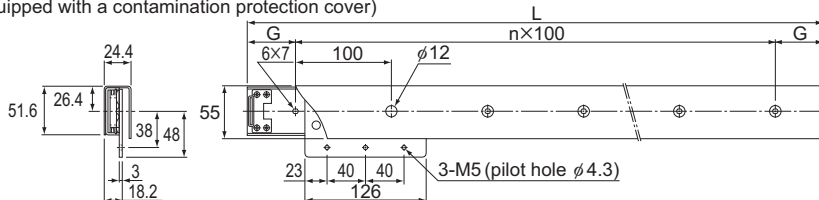

Note: For models equipped with a contamination protection cover, the rubber seal is not available.

Jointed Slide Rails

If the required specifications exceed the standard stroke, two or more slide rails can be connected. When placing an order, indicate the overall length.



Joint Specification Example

Model Number Coding

Model number configurations differ depending on the model features. Refer to the corresponding sample model number configuration.

Slide Pack

- Models FBW2560XR, FBW3590XR, and FBW50110XR

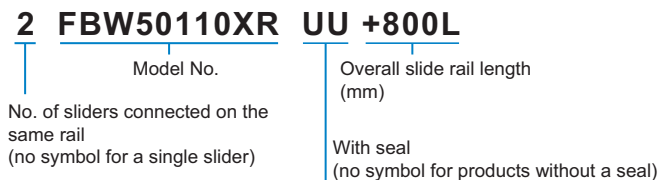

- Joint specifications

FBW50110XR UU +800L - T

Jointed slide rails symbol

- With metal dust cover

FBW50110XRG +800L

With metal dust cover

Notes: If units are to be joined, provide a diagram or sketch clearly showing the joined length.
 Metal dust covers that fit over the entire slide rail and prevent foreign material from entering the slide are available for Slide Pack Model FBW. (See **A12-9**.)
 A seal is not available for models equipped with a metal dust cover.

Handling Precautions

Slide Pack

Handling

- (1) Do not disassemble the parts. This will result in loss of functionality.
- (2) Tilting the slider or slide rail may cause them to fall by their own weight.
- (3) Take care not to drop or strike the slide pack. Otherwise, it may cause injury or damage the unit. Even if there is no outward indication of damage, a sudden impact could prevent the unit from functioning properly.
- (4) Wear appropriate safety gear, such as protective gloves and safety shoes, when handling the product.

Use

- (1) The static permissible load of the slide pack varies according to the direction.
- (2) Prevent foreign material, such as cutting chips or coolant, from entering the product. Failure to do so could damage the product.
- (3) Prevent foreign materials, such as cutting chips, coolant, corrosive solvents, or water from getting in the product by using a bellows or cover when the product is used in an environment where such a thing is likely.
- (4) If foreign materials such as cutting chips adhere to the product, replenish the lubricant after cleaning the product.
- (5) Do not subject this product to harsh conditions, such as an abnormally hot, cold, damp, or dusty environment, or intense repeated motion that would cause it to heat up due to friction. Use of this product under such conditions can result in damage or loss of functionality.
- (6) If the slide pack will be used in an inverted orientation, take preventive measures such as adding a safety mechanism to prevent items from falling. If the slider is damaged due to an accident, etc., balls may fall out or the slider may become detached from the slide rail and fall down.
- (7) When you remove the slider from the slide rail and then reassemble them, inserting the slide rail into the slider while twisting them may cause balls to fall or damage the slider. Be sure to gently insert the rail straight into the slider while checking the position of the slider balls and the rail raceway.
- (8) Do not use the supplied stopper as a mechanical stopper. This may damage the stopper due to impact.
- (9) Do not forcibly drive a pin, key, or other positioning device into the product. This could create indentations on the raceway and impair the product's function.
- (10) Using the product while rolling elements are missing could lead to premature failure of the product.
- (11) If any rolling elements fall out, contact THK. Do not use the product in that condition.
- (12) If the mounting material lacks sufficient rigidity or accuracy, the bearing load may be focused in one area, and bearing functionality will dramatically decrease. Therefore, carefully consider the rigidity and accuracy of the housing and base, and the strength of the securing bolts.

Lubrication

- (1) Lithium soap-based grease No. 2 is applied to the slider and ball circulation components. Do not mix different lubricants. Even greases containing the same type of thickening agent may, if mixed, interact negatively due to disparate additives or other ingredients.
- (2) The consistency of grease changes according to the temperature. Take note that the slide pack's sliding resistance may be affected by changes in viscosity.

Handling Precautions

- (3) After lubrication, the sliding resistance of the slide pack may increase due to the stirring resistance of the grease. Be sure to let the grease break in fully before use.
- (4) Excess grease may spatter after lubrication. Wipe off spattered grease as necessary.
- (5) Grease deteriorates over time, which decreases the lubricity, so perform regular grease inspections and replenish grease based on frequency of use.
- (6) However, note that the lubrication interval may vary according to operating conditions and the service environment. Set the final lubrication interval/amount based on the actual machine.

Storage

When storing the slide pack, pack it as designated by THK and store it indoors in a horizontal position away from extreme heat or cold and high humidity.

Please note that if the product has been kept in storage for an extended period, the lubricant inside may have deteriorated. Please ensure that you replenish the lubricant before use.

Disposal

The product should be treated as industrial waste and disposed of appropriately.



Slide Pack

THK General Catalog

B Support Book

Features and Types	A12-2
Features of the Slide Pack	A12-2
• Structure and Features	A12-2
Types of Slide Pack	A12-3
• Types	A12-3
Mounting Procedure and Maintenance ..	A12-4
Installation	A12-4
Lubrication	A12-5
Example Applications	A12-5
Model No.	A12-6
• Model Number Coding	A12-6
Handling Precautions	A12-7

A Product Descriptions (Separate)

Features and Types	A12-2
Features of the Slide Pack	A12-2
• Structure and Features	A12-2
Types of Slide Pack	A12-3
• Types	A12-3
• Clearance	A12-3
Dimensional Drawing, Dimensional Table	
Model FBW2560XR	A12-4
Model FBW3590XR	A12-5
Model FBW50110XR	A12-6
Design Highlights	A12-7
Installation	A12-7
Lubrication	A12-8
Example Applications	A12-8
Options	A12-9
Contamination Protection	A12-9
Metal Dust Cover	A12-9
Jointed Slide Rails	A12-10
Model No.	A12-11
• Model Number Coding	A12-11
Handling Precautions	A12-12

Features of the Slide Pack

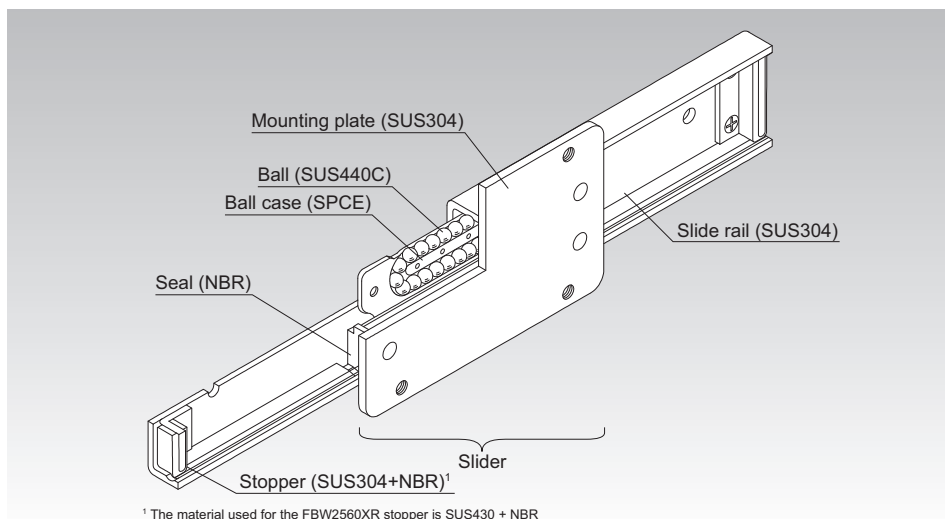

Fig. 1: Structure of Slide Pack Model FBW-XRUU

Structure and Features

Slide Pack Model FBW-XR is an LM System in which a precision-press-molded slider that contains balls performs infinite linear motion. Used in combination with a slide rail, the slide pack achieves lightweight and compact design and smooth linear motion.

This product is optimal for light-load slide units in products such as photocopiers, tool cabinets, electronic equipment cabinets, automatic vending machines, machine tool slide covers, cash registers, and curtain walls.

High Corrosion Resistance

Austenitic stainless steel is used in components such as rails, mounting plates, and stoppers to ensure excellent corrosion resistance.

Low Noise

The slider unit in the FBW2560XR, FBW3590XR, and 50110XR has been redesigned to provide noise levels 5 dBA lower than the previous models (at a speed of 60 m/min. in the FBW3590XR).

Types of Slide Pack

Types

Model FBW 2560XR

Dimensional Table⇒ **A** 12-4

This model is a compact type.

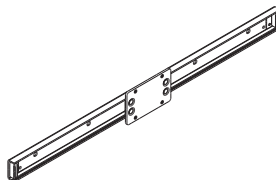

Model FBW 3590XR

Dimensional Table⇒ **A** 12-5

This model is the standard type.

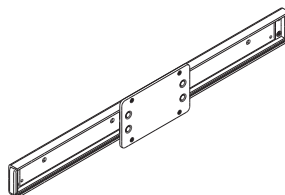

Model FBW 50110XR

Dimensional Table⇒ **A** 12-6

This model is a heavy-load type.

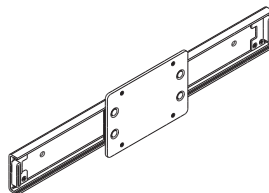

Installation

Slide Rail Mounting Screws

Since the space for securing the mounting screws of the slide rail is small, as shown in Fig. 1, we recommend using button head bolts or binding head bolts (JIS B 1111 annex).

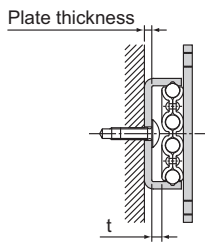

Fig. 1

Unit: mm

Model No.	Mounting screw size	Rail plate thickness	t
FBW 2560XR	M4	1.5	3.2
FBW 3590XR	M4	2.5	3.4
FBW 50110XR	M5	2.5	3.4

Attaching the Stopper

If the slider may overshoot and come off of the slide rail, attach the dedicated stopper to the slide rail end as shown in Fig. 2.



Fig. 2

Installing the Slider

With model FBW-XR, balls will not fall off even if the slider is removed from the slide rail. However, they could fall if the slider is twisted when reattaching it to the slide rail. Whenever possible, do not remove the slider from the slide rail when installing the slide pack.

Groove Dimensions

The groove dimensions when model FBW-XR is installed in a groove are shown in Fig. 3.

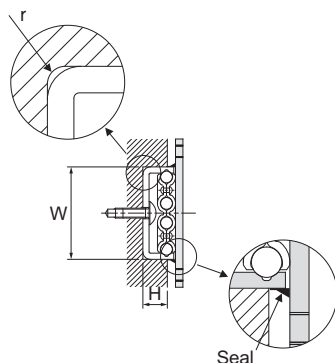

Fig. 3

Unit: mm

Model No.	W	H	r (max)
FBW 2560XR	24.8 ^{+0.15} / _{+0.1}	7.4	1
FBW 3590XR	37.4 ^{+0.15} / _{+0.1}	10	2
FBW 50110XR	50.4 ^{+0.15} / _{+0.1}	10	2.5

Note: The groove width for the FBW3590XR and 50110XR is 0.4 mm more than for the previous models (3590R and 50110R).

Lubrication

High-quality lithium soap-based grease is applied to the slide and ball circulation areas.

Example Applications

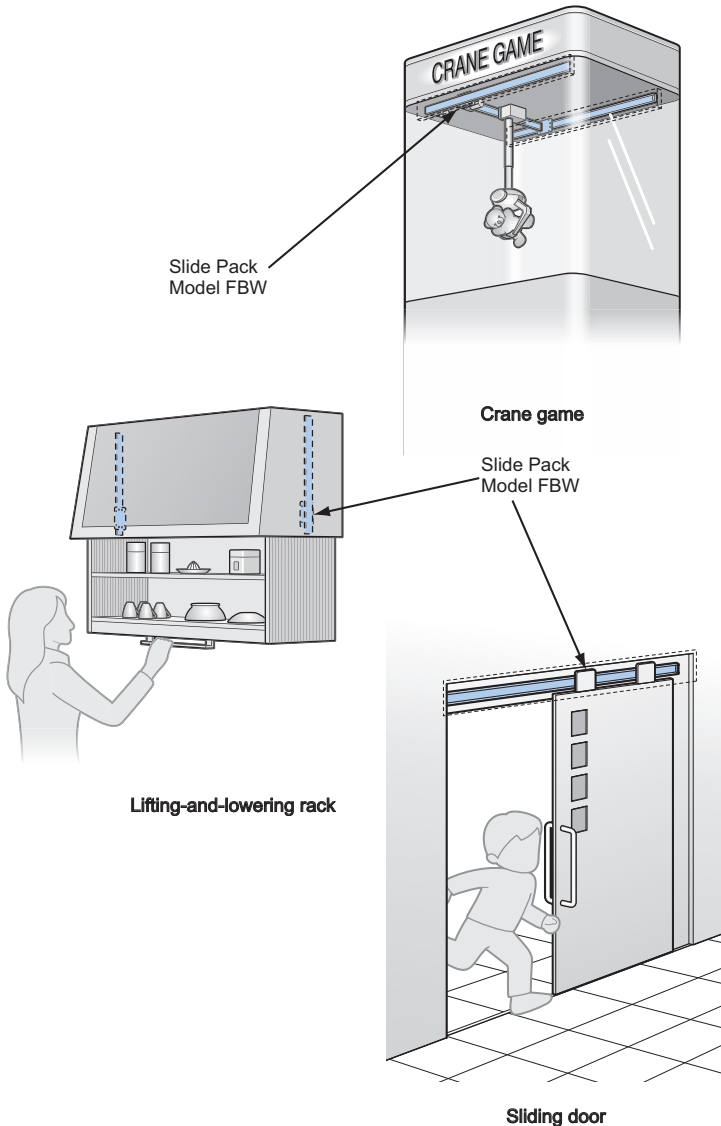

Model Number Coding

Model number configurations differ depending on the model features. Refer to the corresponding sample model number configuration.

Slide Pack

● Models FBW2560XR, FBW3590XR, and FBW50110XR

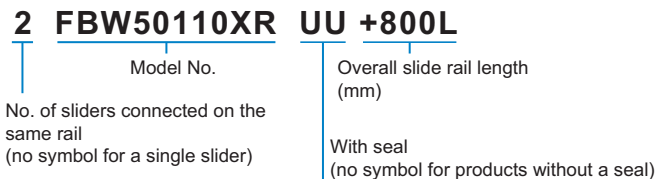

● Joint specifications

FBW50110XR UU +800L - T

Jointed slide rails symbol

● With metal dust cover

FBW50110XRG +800L

With metal dust cover

Notes: If units are to be joined, provide a diagram or sketch clearly showing the joined length.
 Metal dust covers that fit over the entire slide rail and prevent foreign material from entering the slide are available for Slide Pack Model FBW. (See **■12-9**.)
 A seal is not available for models equipped with a metal dust cover.

Handling Precautions

Slide Pack

Handling

- (1) Do not disassemble the parts. This will result in loss of functionality.
- (2) Tilting the slider or slide rail may cause them to fall by their own weight.
- (3) Take care not to drop or strike the slide pack. Otherwise, it may cause injury or damage the unit. Even if there is no outward indication of damage, a sudden impact could prevent the unit from functioning properly.
- (4) Wear appropriate safety gear, such as protective gloves and safety shoes, when handling the product.

Use

- (1) The static permissible load of the slide pack varies according to the direction.
- (2) Prevent foreign material, such as cutting chips or coolant, from entering the product. Failure to do so could damage the product.
- (3) Prevent foreign materials, such as cutting chips, coolant, corrosive solvents, or water from getting in the product by using a bellows or cover when the product is used in an environment where such a thing is likely.
- (4) If foreign materials such as cutting chips adhere to the product, replenish the lubricant after cleaning the product.
- (5) Do not subject this product to harsh conditions, such as an abnormally hot, cold, damp, or dusty environment, or intense repeated motion that would cause it to heat up due to friction. Use of this product under such conditions can result in damage or loss of functionality.
- (6) If the slide pack will be used in an inverted orientation, take preventive measures such as adding a safety mechanism to prevent items from falling. If the slider is damaged due to an accident, etc., balls may fall out or the slider may become detached from the slide rail and fall down.
- (7) When you remove the slider from the slide rail and then reassemble them, inserting the slide rail into the slider while twisting them may cause balls to fall or damage the slider. Be sure to gently insert the rail straight into the slider while checking the position of the slider balls and the rail raceway.
- (8) Do not use the supplied stopper as a mechanical stopper. This may damage the stopper due to impact.
- (9) Do not forcibly drive a pin, key, or other positioning device into the product. This could create indentations on the raceway and impair the product's function.
- (10) Using the product while rolling elements are missing could lead to premature failure of the product.
- (11) If any rolling elements fall out, contact THK. Do not use the product in that condition.
- (12) If the mounting material lacks sufficient rigidity or accuracy, the bearing load may be focused in one area, and bearing functionality will dramatically decrease. Therefore, carefully consider the rigidity and accuracy of the housing and base, and the strength of the securing bolts.

Lubrication

- (1) Lithium soap-based grease No. 2 is applied to the slider and ball circulation components. Do not mix different lubricants. Even greases containing the same type of thickening agent may, if mixed, interact negatively due to disparate additives or other ingredients.
- (2) The consistency of grease changes according to the temperature. Take note that the slide pack's sliding resistance may be affected by changes in viscosity.

- (3) After lubrication, the sliding resistance of the slide pack may increase due to the stirring resistance of the grease. Be sure to let the grease break in fully before use.
- (4) Excess grease may spatter after lubrication. Wipe off spattered grease as necessary.
- (5) Grease deteriorates over time, which decreases the lubricity, so perform regular grease inspections and replenish grease based on frequency of use.
- (6) The lubrication interval may vary according to operating conditions and the service environment. Set the final lubrication interval/amount based on the actual machine.

Storage

When storing the slide pack, pack it as designated by THK and store it indoors in a horizontal position away from extreme heat or cold and high humidity.

Please note that if the product has been kept in storage for an extended period, the lubricant inside may have deteriorated. Please ensure that you replenish the lubricant before using.

Disposal

The product should be treated as industrial waste and disposed of appropriately.