

Model LT-X

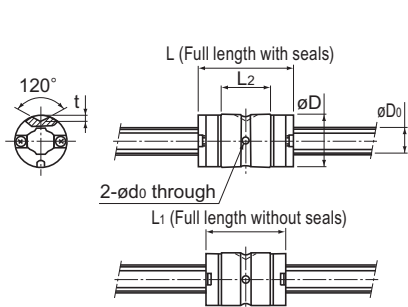

Model LT4X

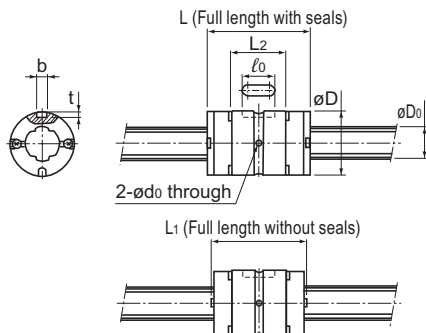

Models LT5X to 8X

Model No.	Spline shaft diameter		Spline nut dimensions							
	D ₀ h7	Outer diameter		Length			Keyway dimensions			Lubrication hole
		D	Tolerance	L (With seals)	L ₁ (Without seals)	L ₂	b H8	t	l ₀	d ₀
LT 4X	4	8	$\begin{matrix} 0 \\ -0.009 \end{matrix}$	14.4	12	7.5	—	1	—	1
LT 5X LT 5XL	5	10	$\begin{matrix} 0 \\ -0.009 \end{matrix}$	15 26	13.6 24.6	7.3 18.3	2	1.2	4.7	1
LT 6X LT 6XL	6	12	$\begin{matrix} 0 \\ -0.011 \end{matrix}$	19 30	17.6 28.6	10.2 21.2	2	1.2	6	1
LT 8X LT 8XL	8	15	$\begin{matrix} 0 \\ -0.011 \end{matrix}$	25 40	23.8 38.8	14.6 29.6	2.5	1.2	8	1.5
LT 10X	10	19	$\begin{matrix} 0 \\ -0.013 \end{matrix}$	33	30.8	23.9	3	1.5	13	1.5
LT 13X	13	23	$\begin{matrix} 0 \\ -0.013 \end{matrix}$	36	32.4	24	3	1.5	15	1.5
LT 16X	16	28	$\begin{matrix} 0 \\ -0.013 \end{matrix}$	50	46.4	35.5	3.5	2	17.5	2
LT 20X	20	32	$\begin{matrix} 0 \\ -0.016 \end{matrix}$	63	59	47.4	4	2.5	29	2
LT 25X	25	40	$\begin{matrix} 0 \\ -0.016 \end{matrix}$	71	67	52.6	4	2.5	36	3
LT 30X	30	45	$\begin{matrix} 0 \\ -0.016 \end{matrix}$	80	75.6	59.6	4	2.5	42	3

Model number coding

2 LT20X UU CL +700L P K

Model No.	Symbol for clearance in the rotational direction ²	Accuracy symbol ³	Symbol for spline shaft ⁴
Number of spline nuts on one shaft (no symbol for one nut)	Contamination protection accessory symbol ¹	Overall spline shaft length ⁵ (in mm)	

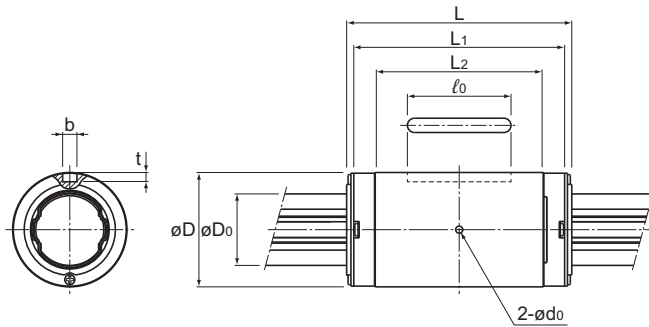

¹ See **A3-128**. ² See **A3-32**. ³ See **A3-37**. ⁴ See **A3-95**. ⁵ See **A3-123**.

Medium-Torque Ball Spline



Models LT10X to 30X

Unit: mm

	Basic torque rating		Basic load rating		Static permissible moment			Mass	
	C_T N·m	C_{OT} N·m	C kN	C_0 kN	M_{A1}  N·m	M_{A2} (With seal)  N·m	M_{A2} (Without seal)  N·m	Spline nut g	Spline shaft kg/m
	0.49	0.82	0.42	0.7	0.84	6.2	5	2.2	0.1
	0.82 1.59	1.25 3.2	0.56 1.09	0.85 2.19	1.04 6.11	8.2 35.5	6.6 28.4	3.3 8	0.15
	1.73 2.81	2.77 5.54	0.98 1.6	1.58 3.15	2.85 10.6	19 59.8	15.2 47.8	6.6 13.3	0.21
	6 10.1	9.23 19.5	1.39 2.35	2.15 4.53	5.13 21.1	34.3 110.9	27.4 88.7	14.3 24.3	0.38
	9.41	17.3	2.94	5.4	21.5	114	104	30	0.59
	17.1	28.7	4.16	6.96	28.9	164	149	40	1.01
	42.9	68.6	8.4	13.4	77.4	419	381	81	1.52
	66.4	117	10.5	18.6	144	735	669	130	2.41
	125	207	15.9	26.2	230	1,183	1,077	235	3.71
	196	319	20.8	34	335	1,714	1,560	295	5.37

Notes: The mass of the spline nut does not include the seal.
Please check the spline shaft strength tests (A3-12) before use.