

SRG

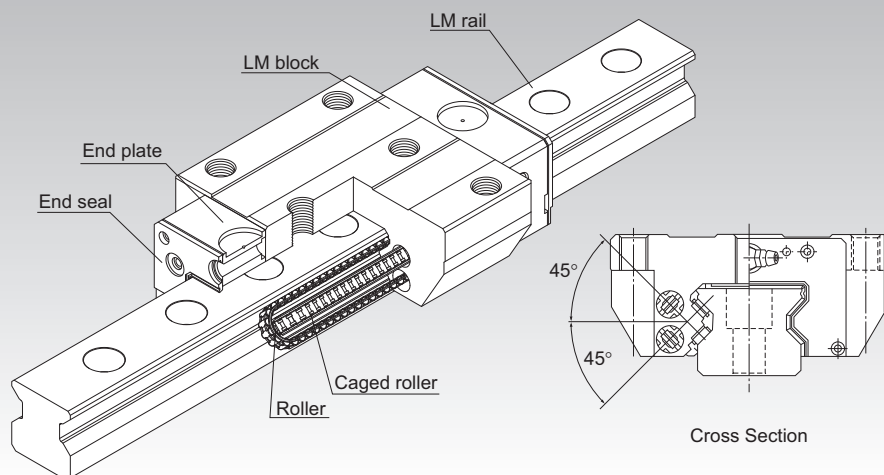

Ultra-Rigid Caged Roller LM Guide Model SRG



Note: For the caged roller, see **A1-414**.

Selection Criteria **A1-10**

Design Highlights **A1-482**

Options **A1-507**

Model No. **A1-577**

Handling Precautions **A1-583**

Accessories for Lubrication **A24-1**

Mounting Procedure **B1-89**

Equivalent Moment Factor **A1-43**

Rated Loads in All Directions **A1-61**

Equivalent Factor in Each Direction **A1-63**

Radial Clearance **A1-75**

Accuracy Standards **A1-79**

Shoulder Height of the Mounting Base and the Corner Radius **A1-494**

Reference Error Tolerance for the Mounting Surface **A1-423**

Dimensions of Each Model with Options Attached **A1-521**

Structure and Features

Rollers roll in four rows of raceways precision-ground on the LM rail and LM block, and roller cages and end plates incorporated in the LM block allow the balls to circulate.

The SRG is an ultra-rigid roller guide that uses roller cages to reduce friction, move smoothly, and achieve long-term maintenance-free operation.

Ultra-High Rigidity

Increased rigidity is achieved by using highly rigid rollers as the rolling elements and having the overall roller length more than 1.5 times greater than the roller diameter.

4-Way Equal Load

Since each row of rollers is arranged at a contact angle of 45° so that the LM block receives an equal load rating in all four directions (radial, reverse-radial, and lateral directions), high rigidity is ensured in all directions.

Smooth Motion through Skewing Prevention

The roller cage allows rollers to form an evenly spaced line while circulating, thus preventing the rollers from skewing as the block enters a loaded area. This minimizes rolling resistance fluctuation and achieves stable, smooth motion.

Long-Term Maintenance-Free Operation

Use of roller cages eliminates friction between rollers and increases grease retention, enabling long-term maintenance-free operation.

Global Standard Size

SRG is designed to have dimensions nearly equal to the Full-Ball LM Guide Model HSR, THK's pioneer LM System and the de facto global standard.

Wide Array of Options

Various options are available, including end seals, inner seals, side seals, Laminated Contact Scraper LaCS, protectors, side scrapers, High Chemical Resistance Fluorine Seal FS, and GC caps, to accommodate various usage environments.

Types and Features

Models SRG15XA, 20XA

The flange of the LM block has tapped holes. It can be mounted from the top or the bottom.

Dimensional Table⇒ **A1-424**

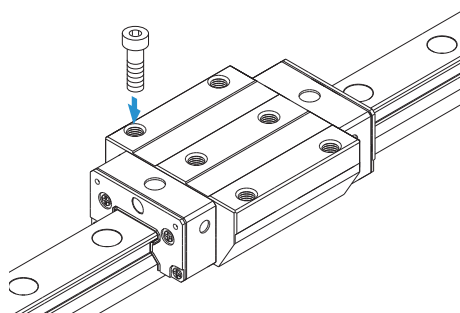

Model SRG20XLA

The LM block has the same cross-sectional shape as model SRG-A, but has a longer overall LM block length (L) and a greater load rating.

Dimensional Table⇒ **A1-424**

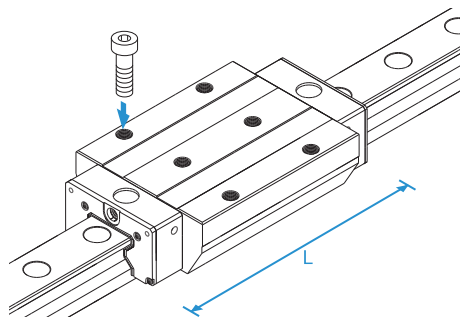

Model SRG-C

The flange of the LM block has tapped holes. It can be mounted from the top or the bottom. It is used in places where the table cannot have through holes for mounting bolts.

Dimensional Table → **A1-424**

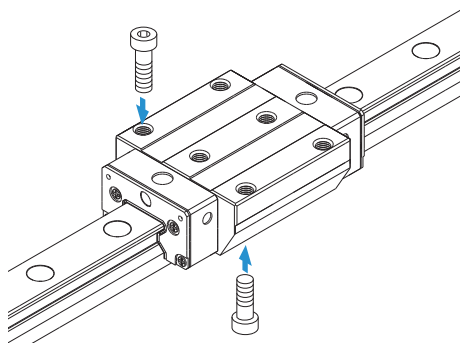

Model SRG-LC

The LM block has the same cross-sectional shape as model SRG-C, but has a longer overall LM block length (L) and a greater load rating.

Dimensional Table → **A1-424**

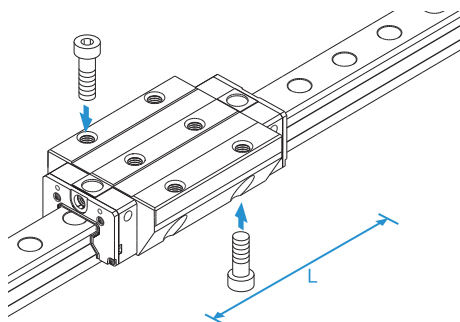

Model SRG-SLC

The LM block has the same cross-sectional shape as model SRG-LC, but has a longer overall LM block length (L) and a greater load rating.

Dimensional Table → **A1-426**

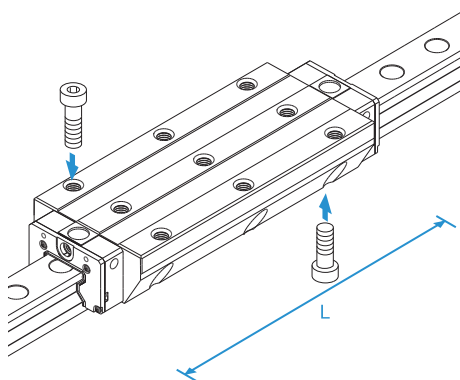

Models SRG-V/R

With this type, the LM block has a smaller width (W) and tapped holes. It is used in places where the space for table width is limited.

Dimensional Table⇒ [A1-432](#)

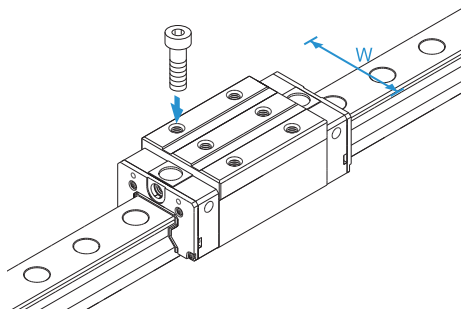

Models SRG-LV/LR

The LM block has the same cross-sectional shape as the Model SRG-V/R, but has a longer overall LM block length (L) and a greater load rating.

Dimensional Table⇒ [A1-432](#)

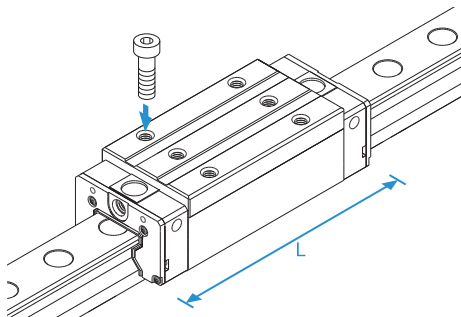

Models SRG-SLV/SLR

The LM block has the same cross-sectional shape as the Model SRG-LV/LR, but has a longer overall LM block length (L) and a greater load rating.

Dimensional Table⇒ [A1-434](#)

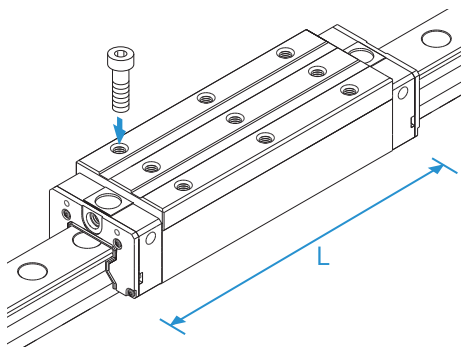

SRG-G

Dimensional Table⇒ [A1-424](#) to [A1-437](#)

The SRG-G, a model equipped with uncaged, full-complement bearings, is also available. Due to its cageless design, however, the SRG-G's dynamic load rating is lower than that of standard SRG models. For specific data, please refer to the dimension tables in this catalog.

Reference Error Tolerance for the Mounting Surface

The Caged Roller LM Guide Model SRG features high rigidity because it uses rollers as its rolling element. It also contains a roller cage that prevents the rollers from skewing. However, high machining accuracy is required in the mounting surface. Large error on the mounting surface will affect the rolling resistance and the service life. The following shows the reference error tolerance according to the radial clearance.

Table 1: Reference Horizontal Error Tolerance (P) between Two Rails

Unit: μm

Radial clearance	Normal	C1	C0
Model No.			
SRG 15X	5	3	3
SRG 20X	8	6	4
SRG 25X	9	7	5
SRG 30X	11	8	6
SRG 35	14	10	7
SRG 45	17	13	9
SRG 55	21	14	11
SRG 65	27	18	14
SRG 85	40	27	21
SRG 100	45	31	24

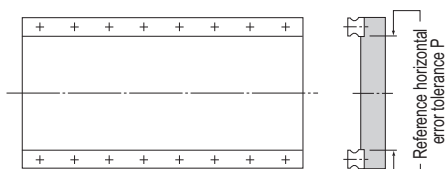

Fig. 1

Table 2: Reference Vertical Error Tolerance (X) between Two Rails

Unit: mm

Radial clearance	Normal	C1	C0
Reference vertical error tolerance X	0.0003a	0.00021a	0.00011a

$X = X_1 + X_2$ X_1 : Level difference on the rail mounting surface

X_2 : Level difference on the block mounting surface

Example of calculation

Rail span when $a = 500$ mm

Reference vertical error tolerance $X = 0.0003 \times 500 = 0.15$

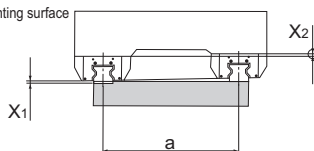

Fig. 2

Table 3: Reference Vertical Error Tolerance (Y) in the Axial Direction

Unit: mm

Reference vertical error tolerance Y	0.000036b
--------------------------------------	-----------

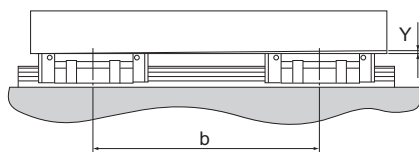
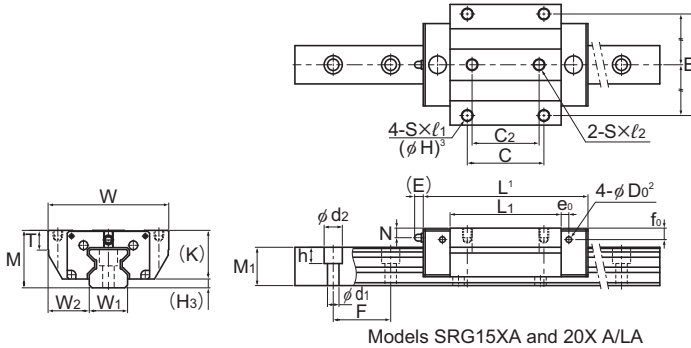

Fig. 3

Models SRG-A, SRG-LA, SRG-C, and SRG-LC



Model No.	Outer dimensions			LM block dimensions														Pilot hole for side nipple			
	Height	Width	Length															Grease nipple	e ₀	f ₀₄	D _ø ²
	M	W	L	B	C	C ₂	S	H	ℓ ₁	ℓ ₂	L ₁	T	T ₁	K	N	E					
SRG 15XA SRG 15XGA	24	47	69.2	38	30	26	M5	(4.3) ³	8	7.5	45	7	(8) ³	20	4	4.5	PB107	4	6	2.9	
SRG 20XA SRG 20XGA	30	63	86.2	53	40	35	M6	(5.4) ³	10	9	58	10	(10) ³	25.4	5	4.5	PB107	4	6	2.9	
SRG 20XLA SRG 20XGLA	30	63	106.2	53	40	35	M6	(5.4) ³	10	9	78	10	(10) ³	25.4	5	4.5	PB107	4	6	2.9	
SRG 25XC SRG 25XGC	36	70	95.1	57	45	40	M8	6.8	—	—	65.5	9.5	10	31.5	5.5	12	B-M6F	6	7.3	5.2	
SRG 25XLC SRG 25XGLC	36	70	115.1	57	45	40	M8	6.8	—	—	85.5	9.5	10	31.5	5.5	12	B-M6F	6	7.3	5.2	
SRG 30XC SRG 30XGC	42	90	111	72	52	44	M10	8.5	—	—	75	12	14	37	6.5	12	B-M6F	6	7.5	5.2	
SRG 30XLC SRG 30XGLC	42	90	135	72	52	44	M10	8.5	—	—	99	12	14	37	6.5	12	B-M6F	6	7.5	5.2	

Model number coding

SRG30X LC 2 QZ TTHH C0 +1240L P Z T - II

Model number

Type of LM block

With QZ Lubricator

Contamination protection accessory symbol

LM rail length (in mm)

With plate cover

Symbol for No. of rails used on the same plane

No. of LM blocks used on the same rail

Radial clearance symbol
Normal (No symbol)
Light preload (C1)
Medium preload (C0)

Accuracy symbol
High accuracy grade (H)/Precision grade (P)
Super precision grade (SP)/Ultra precision grade (UP)

Symbol for LM rail jointed use

Notes: This model number indicates that a single-rail unit constitutes one set (i.e., required number of sets when 2 rails are used in parallel is 2 at a minimum).

Grease nipples are not installed when there is a QZ Lubricator. Contact THK if you want to use a grease nipple for a model with a QZ. See [A1-547](#) for contamination protection accessories, see [A1-75](#) for radial clearance symbol. See [A1-79](#) for accuracy symbol. See [A1-13](#) for symbol for number of rails used on the same plane.

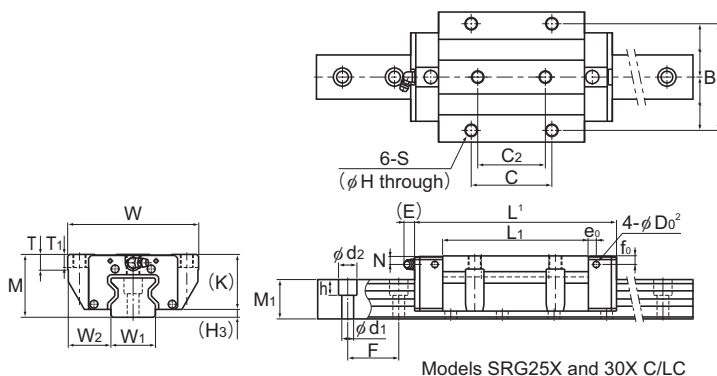

Models SRG25X and 30X C/LC

Unit: mm

H ₃	LM rail dimensions						Basic load rating ¹		Static permissible moment kN·m ⁶					Mass	
	W ₁ 0 -0.05	W ₂	M ₁	Pitch F	d ₁ × d ₂ × h	Length ⁴ Max	C kN	C ₀ kN	M _A		M _B		M _C	LM block kg	LM rail kg/m
									1 block	2 blocks	1 block	2 blocks	1 block		
4	15	16	15.5	30	4.5 × 7.5 × 5.3	3000	11.3 11.3	25.8 30.9	0.21 0.25	1.24 1.49	0.21 0.25	1.24 1.49	0.24 0.3	0.2	1.58
4.6	20	21.5	20	30	6 × 9.5 × 8.5	3000	21 20.6	46.9 54.4	0.48 0.56	2.74 3.25	0.48 0.56	2.74 3.25	0.58 0.68	0.42	2.58
4.6	20	21.5	20	30	6 × 9.5 × 8.5	3000	26.7 25.9	63.8 73.1	0.88 0.99	4.49 5.27	0.88 0.99	4.49 5.25	0.79 0.91	0.57	2.58
4.5	23	23.5	23	30	7 × 11 × 9	3000	27.9 26.7	57.5 65	0.64 0.76	3.7 4.31	0.64 0.76	3.7 4.31	0.8 0.9	0.7	3.6
4.5	23	23.5	23	30	7 × 11 × 9	3000	34.2 32.9	75 85	1.07 1.27	5.74 6.69	1.07 1.27	5.74 6.69	1.03 1.18	0.9	3.6
5	28	31	26	40	9 × 14 × 12	3000	39.3 38.7	82.5 96.9	1.02 1.23	6.21 7.25	1.02 1.23	6.21 7.25	1.47 1.62	1.2	4.4
5	28	31	26	40	9 × 14 × 12	3000	48.3 47.4	108 126	1.76 2.04	9.73 11.3	1.76 2.04	9.73 11.3	1.92 2.11	1.6	4.4

¹ Length L shown in the table is the length with the contamination protection accessories, code UU or SS.
If other contamination protection accessories or lubricant equipment are installed, the total block length will increase. (See **A1-521** or **A1-543**)

² D₀ are the pilot holes for when a grease nipple is desired for a product with LaCS or a QZ Lubricator.
Pilot holes are not drilled through for models other than those stated above.
For grease nipple mount machining, contact THK.

³ The values in parentheses are the dimensions when SRG15XA, 20XA, or 20XLA are machined with an inverted counterbore. If the mounting holes (4 holes) of the LM block are machined with an inverted counterbore, these models can be mounted to the table from the bottom. Contact THK for details.

⁴ The maximum length indicates the standard maximum length of an LM rail. (See **A1-438**.)

⁵ The basic dynamic load rating of the roller guide is a value based on a nominal life of 100 km.

The conversion to basic dynamic load rating for a nominal life of 50 km can be obtained from the following equation.

$$C_{50} = C \times 1.23$$

C₅₀ : The basic dynamic load rating for a nominal load of 50 km

C : The basic dynamic load rating in the dimensional table

⁶ Static permissible moment

1 block: the static permissible moment with one LM block

2 blocks: the static permissible moment with two LM blocks in close contact with each other

Notes: The SRG-G is a cageless, Full-Roller type.

For oil lubrication, be certain to let THK know the mounting orientation and where the LM block piping joint should be attached.

(Mounting orientation: see **A1-12**, Lubricant: see **A24-2**)

The removing/mounting jig is not provided as standard. To obtain one, please contact THK.

Models SRG-C, SRG-LC, and SRG-SLC

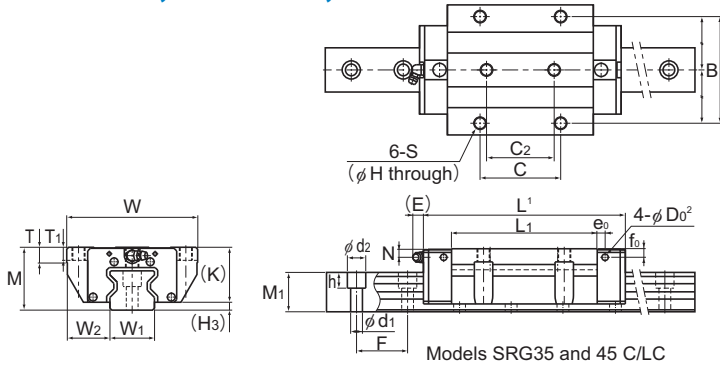

Model No.	Outer dimensions			LM block dimensions													Pilot hole for side nipple		
	Height	Width	Length ¹	B	C	C ₂	S	H	L ₁	T	T ₁	K	N	E	Grease nipple	e ₀	f ₀	D ₀ ²	
	M	W	L																
SRG 35C SRG 35GC	48	100	125	82	62	52	M10	8.5	82.2	11.5	10	42	6.5	12	B-M6F	6	6	5.2	
SRG 35LC SRG 35GLC	48	100	155	82	62	52	M10	8.5	112.2	11.5	10	42	6.5	12	B-M6F	6	6	5.2	
SRG 35SLC SRG 35GSLC	48	100	180.8	82	100	—	M10	8.5	138	11.5	10	42	6.5	12	B-M6F	6	6	5.2	
SRG 45C SRG 45GC	60	120	155	100	80	60	M12	10.5	107	14.5	15	52	10	16	B-PT1/8	7	7	5.2	
SRG 45LC SRG 45GLC	60	120	190	100	80	60	M12	10.5	142	14.5	15	52	10	16	B-PT1/8	7	7	5.2	
SRG 45SLC SRG 45GSLC	60	120	231.5	100	120	—	M12	10.5	183.5	14.5	15	52	10	16	B-PT1/8	7	7	5.2	

Model number coding

SRG45	LC	2	QZ	TTTH	C0	+1200L	P	Z	T	-II
Model number	Type of LM block	No. of LM blocks used on the same rail	With QZ Lubricator	Contamination protection accessory symbol	Radial clearance symbol Normal (No symbol)/Light preload (C1) Medium preload (C0)/Heavy preload (CN1) Super heavy preload (CN2)	LM rail length (in mm)	Accuracy symbol High accuracy grade (H)/Precision grade (P) Super precision grade (SP)/Ultra precision grade (UP)	With plate cover	Symbol for LM rail jointed use	Symbol for No. of rails used on the same plane

Notes: This model number indicates that a single-rail unit constitutes one set (i.e., required number of sets when 2 rails are used in parallel is 2 at a minimum).

Grease nipples are not installed when there is a QZ Lubricator. Contact THK if you want to use a grease nipple for a model with a QZ. See [A1-547](#) for contamination protection accessories, see [A1-75](#) for radial clearance symbol. See [A1-79](#) for accuracy symbol. See [A1-13](#) for symbol for number of rails used on the same plane.

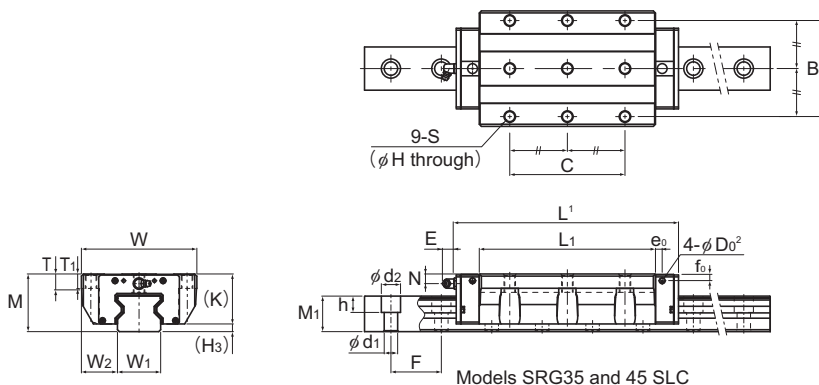

Models SRG35 and 45 SLC

Unit: mm

H ₃	LM rail dimensions							Basic load rating ¹		Static permissible moment kN·m ⁵					Mass	
	W ₁ 0 -0.05	W ₂	M ₁	F	d ₁ × d ₂ × h	Length ³ Max	C	C ₀	M _A		M _B		M _C	LM block kg	LM rail kg/m	
									1 block	2 blocks	1 block	2 blocks	1 block			
6	34	33	30	40	9 × 14 × 12	3000	59.1	119	1.66	10.1	1.66	10.1	2.39	1.9	6.9	
							55.3	131	1.77	11.1	1.77	11.1	2.69			
6	34	33	30	40	9 × 14 × 12	3000	76	165	3.13	17	3.13	17	3.31	2.4	6.9	
							71.4	182	3.39	18.8	3.39	18.8	3.74			
6	34	33	30	40	9 × 14 × 12	3000	87.9	199	4.53	23.9	4.53	23.9	4.09	3.2	6.9	
							83.4	222	5	26.6	5	26.6	4.56			
8	45	37.5	37	52.5	14 × 20 × 17	3090	91.9	192	3.49	20	3.49	20	4.98	3.7	11.6	
							87.8	216	3.9	22.5	3.9	22.5	5.87			
8	45	37.5	37	52.5	14 × 20 × 17	3090	115	256	6.13	32.2	6.13	32.2	6.64	4.5	11.6	
							110	288	6.87	36.3	6.87	36.3	7.83			
8	45	37.5	37	52.5	14 × 20 × 17	3090	139	328	9.99	50	9.99	50	8.91	6.3	11.6	
							133	368	11.1	56	11.1	56	10			

¹ Length L shown in the table is the length with the contamination protection accessories, code UU or SS.
If other contamination protection accessories or lubricant equipment are installed, the total block length will increase. (See [A1-521](#) or [A1-543](#))

² D₀ are the pilot holes for when a grease nipple is desired for a product with LaCS or a QZ Lubricator.
Pilot holes are not drilled through for models other than those stated above.
For grease nipple mount machining, contact THK.

³ The maximum length indicates the standard maximum length of an LM rail. (See [A1-438](#).)

⁴ The basic dynamic load rating of the roller guide is a value based on a nominal life of 100 km.
The conversion to basic dynamic load rating for a nominal life of 50 km can be obtained from the following equation.

$$C_{50} = C \times 1.23$$

C₅₀ : The basic dynamic load rating for a nominal life of 50 km
C : The basic dynamic load rating in the dimensional table

⁵ Static permissible moment
1 block: the static permissible moment with one LM block
2 blocks: the static permissible moment with two LM blocks in close contact with each other

Notes: The SRG-G is a cageless, Full-Roller type.

For oil lubrication, be certain to let THK know the mounting orientation and where the LM block piping joint should be attached.
(Mounting orientation: see [A1-12](#), Lubricant: see [A24-2](#))

The removing/mounting jig is not provided as standard. To obtain one, please contact THK.

Models SRG-C, SRG-LC, and SRG-SLC

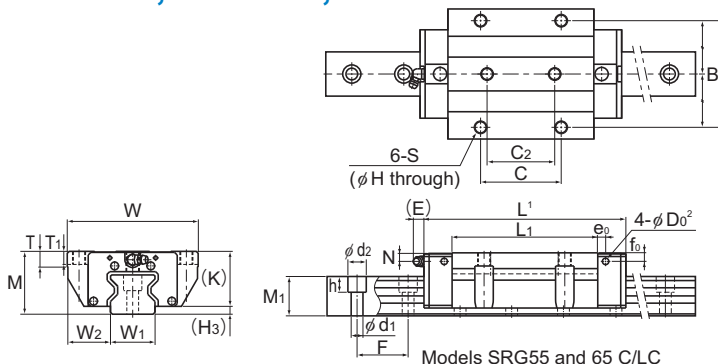

Model No.	Outer dimensions			LM block dimensions												Pilot hole for side nipple		
	Height	Width	Length ¹	B	C	C ₂	S	H	L ₁	T	T ₁	K	N	E	Grease nipple	e ₀	f ₀	D ₀ ²
	M	W	L															
SRG 55C SRG 55GC	70	140	185	116	95	70	M14	12.5	129.2	17.5	18	60	12	16	B-PT1/8	9	8.5	5.2
SRG 55LC SRG 55GLC	70	140	235	116	95	70	M14	12.5	179.2	17.5	18	60	12	16	B-PT1/8	9	8.5	5.2
SRG 55SLC SRG 55GSLC	70	140	292	116	150	—	M14	12.5	236.2	17.5	18	60	12	16	B-PT1/8	9	8.5	5.2
SRG 65C SRG 65GC	90	170	244.9	142	110	82	M16	14.5	171.7	19.5	20	78.5	17	16	B-PT1/8	9	13.5	5.2
SRG 65LC SRG 65GLC	90	170	303	142	110	82	M16	14.5	229.8	19.5	20	78.5	17	16	B-PT1/8	9	13.5	5.2
SRG 65SLC SRG 65GSLC	90	170	380	142	200	—	M16	14.5	306.8	19.5	20	78.5	17	16	B-PT1/8	9	13.5	5.2

Model number coding

SRG65	LC	2	QZ	TT	HH	C0	+1270L	P	Z	T	-II
Model number	Type of LM block	No. of LM blocks used on the same rail	With QZ Lubricator	Contamination protection accessory symbol		Radial clearance symbol Normal (No symbol)/Light preload (C1) Medium preload (C0)/Heavy preload (CN1) Super heavy preload (CN2)	LM rail length (in mm)	Accuracy symbol High accuracy grade (H)/Precision grade (P) Super precision grade (SP)/Ultra precision grade (UP)	With plate cover	Symbol for LM rail jointed use	Symbol for No. of rails used on the same plane

Notes: This model number indicates that a single-rail unit constitutes one set (i.e., required number of sets when 2 rails are used in parallel is 2 at a minimum).

Grease nipples are not installed when there is a QZ Lubricator. Contact THK if you want to use a grease nipple for a model with a QZ. See **A1-547** for contamination protection accessories, see **A1-75** for radial clearance symbol. See **A1-79** for accuracy symbol. See **A1-13** for symbol for number of rails used on the same plane.

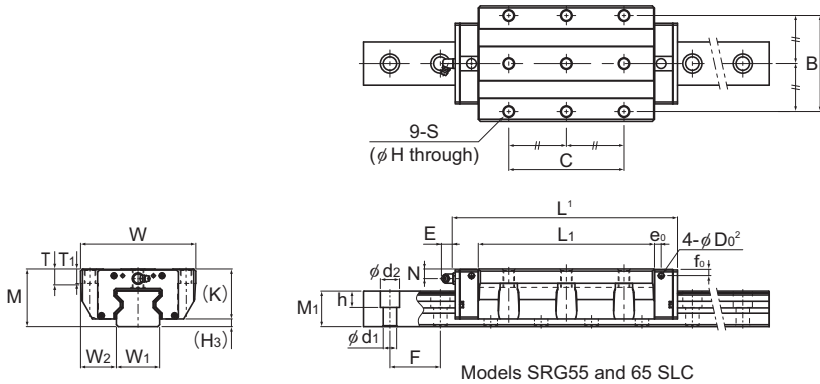

Unit: mm

H ₃	LM rail dimensions							Basic load rating ¹		Static permissible moment kN·m ⁵					Mass	
	Width W ₁ 0 -0.05	Height W ₂	Pitch M ₁	Pitch F	Length ³ d ₁ × d ₂ × h	Length ³ Max	C	C ₀	M _A		M _B		M _C	LM block	LM rail	
									1 block	2 blocks	1 block	2 blocks	1 block	kg	kg/m	
10	53	43.5	43	60	16×23×20	3060	131 125	266 300	5.82 6.5	33 37.2	5.82 6.5	33 37.2	8.19 9.55	5.9	15.8	
10	53	43.5	43	60	16×23×20	3060	167 160	366 411	10.8 12.1	57 64	10.8 12.1	57 64	11.2 13.1	7.8	15.8	
10	53	43.5	43	60	16×23×20	3060	210 199	488 544	19.1 21	93.7 104	19.1 21	93.7 104	15.6 17.3	10.7	15.8	
11.5	63	53.5	54	75	18×26×22	3000	219 214	441 511	12.5 14.8	72.8 83.8	12.5 14.8	72.8 83.8	16.8 19.4	12.5	23.7	
11.5	63	53.5	54	75	18×26×22	3000	278 264	599 670	22.7 25.3	120 135	22.7 25.3	120 135	22.1 25.5	16.4	23.7	
11.5	63	53.5	54	75	18×26×22	3000	352 332	811 899	41.3 45.2	202 224	41.3 45.2	202 224	30.9 25.6	22.3	23.7	

¹ Length L shown in the table is the length with the contamination protection accessories, code UU or SS.
If other contamination protection accessories or lubricant equipment are installed, the total block length will increase. (See [A1-521](#) or [A1-543](#))

² D₀ are the pilot holes for when a grease nipple is desired for a product with LaCS or a QZ Lubricator.
Pilot holes are not drilled through for models other than those stated above.
For grease nipple mount machining, contact THK.

³ The maximum length indicates the standard maximum length of an LM rail. (See [A1-438](#).)

⁴ The basic dynamic load rating of the roller guide is a value based on a nominal life of 100 km.
The conversion to basic dynamic load rating for a nominal life of 50 km can be obtained from the following equation.

$$C_{50} = C \times 1.23$$

C₅₀ : The basic dynamic load rating for a nominal load of 50 km
C : The basic dynamic load rating in the dimensional table

⁵ Static permissible moment
1 block: the static permissible moment with one LM block
2 blocks: the static permissible moment with two LM blocks in close contact with each other

Notes: The SRG-G is a cageless, Full-Roller type.

For oil lubrication, be certain to let THK know the mounting orientation and where the LM block piping joint should be attached.
(Mounting orientation: see [A1-12](#), Lubricant: see [A24-2](#))

The removing/mounting jig is not provided as standard. To obtain one, please contact THK.

Model SRG-LC

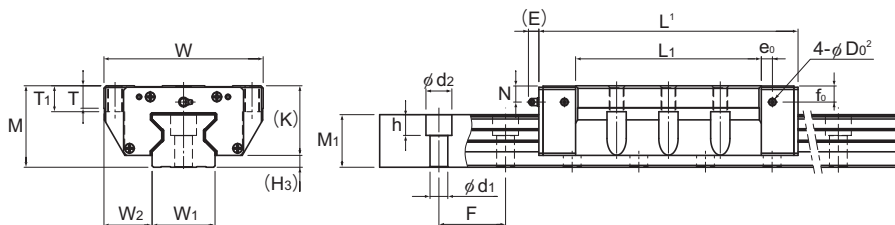
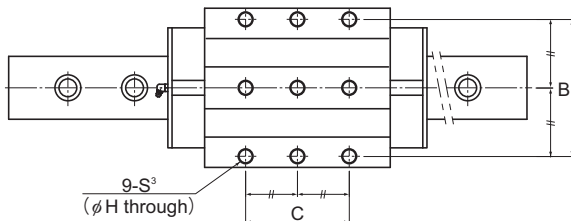

Model SRG85LC

Model No.	Outer dimensions			LM block dimensions											Pilot hole for side nipple				
	Height	Width	Length ¹																
	M	W	L	B	C	S	H	L ₁	T	T ₁	K	N	E	Grease nipple	e ₀	f ₀	D ₀ ²		
SRG 85LC	110	215	350	185	140	M20	17.8	250.8	30	35	94	22	16	B-PT1/8	15	22	8.2		
SRG 100LC	120	250	395	220	200	M20	17.8	280.2	35	38	104	23	16	B-PT1/4	15	23	8.2		

Model number coding

SRG85 LC 2 TT C0 +2610L P Z T - II

Model number

Type of LM block

No. of LM blocks used on the same rail

Contamination protection accessory symbol

Radial clearance symbol
Normal (No symbol)
Light preload (C1)
Medium preload (C0)

LM rail length (in mm)

With plate cover

Accuracy symbol
Precision grade (P)/Super precision grade (SP)
Ultra precision grade (JP)

Symbol for No. of rails used on the same plane

Symbol for LM rail jointed use

Notes: This model number indicates that a single-rail unit constitutes one set (i.e., required number of sets when 2 rails are used in parallel is 2 at a minimum).

Grease nipples are not installed when there is a QZ Lubricator. Contact THK if you want to use a grease nipple for a model with a QZ. See [A1-547](#) for contamination protection accessories, see [A1-75](#) for radial clearance symbol. See [A1-79](#) for accuracy symbol. See [A1-13](#) for symbol for number of rails used on the same plane.

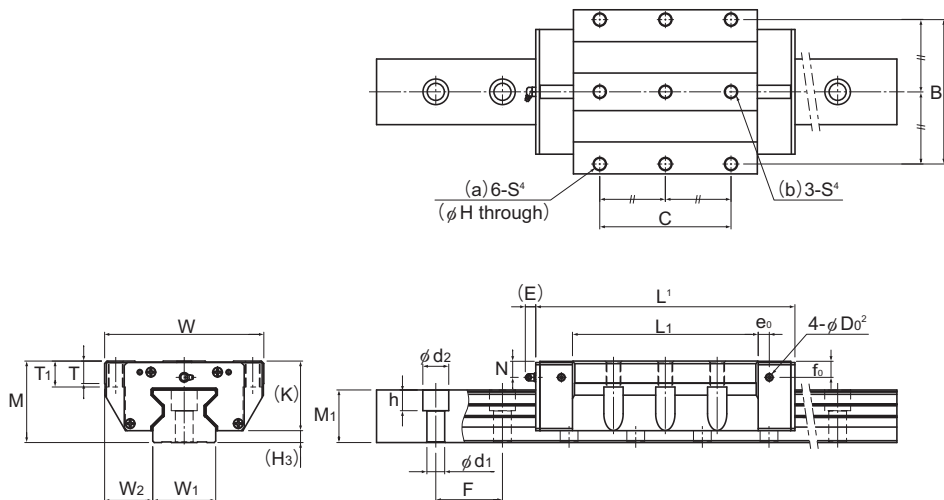

Model SRG100LC

Unit: mm

H ₃	LM rail dimensions					Basic load rating ¹			Static permissible moment kN·m ⁷					Mass	
	Width	Height	Pitch	Length ⁵	C	C ₀	M _A		M _B		M _C	LM block	LM rail		
	W ₁ 0 -0.05	W ₂	M ₁				F	d ₁ × d ₂ × h	Max	kN	kN	1 block	2 blocks	1 block	2 blocks
16	85	65	71	90	24 × 35 × 28	3000	497	990	45.3	239	45.3	239	51.9	26.2	35.7
16	100	75	77	105	26 × 39 × 32	3000	601	1170	60	319	60	319	72.3	37.6	46.8

¹ Length L shown in the table is the length with the contamination protection accessories, code UU or SS.

If other contamination protection accessories or lubricant equipment are installed, the total block length will increase. (See [A1-521](#) or [A1-543](#))

² D₀ are the pilot holes for when a grease nipple is desired for a product with LaCS or a QZ Lubricator.

Pilot holes are not drilled through for models other than those stated above.

For grease nipple mount machining, contact THK.

³ The LM block mounting holes (9 holes) of SRG85LC are all through holes (full thread).

⁴ The LM block mounting holes in part (a) (6 holes) of SRG100LC are through holes (full thread).

The LM block mounting holes in part (b) (3 holes) have effective thread depth of 22 mm.

⁵ The maximum length indicates the standard maximum length of an LM rail. (See [A1-438](#).)

⁶ The basic dynamic load rating of the roller guide is a value based on a nominal life of 100 km.

The conversion to basic dynamic load rating for a nominal life of 50 km can be obtained from the following equation.

$$C_{50} = C \times 1.23$$

C₅₀ : The basic dynamic load rating for a nominal load of 50 km

C : The basic dynamic load rating in the dimensional table

⁷ Static permissible moment

1 block: the static permissible moment with one LM block

2 blocks: the static permissible moment with two LM blocks in close contact with each other

Notes: For oil lubrication, be certain to let THK know the mounting orientation and where the LM block piping joint should be attached.

(Mounting orientation: see [A1-12](#), Lubricant: see [A24-2](#))

The removing/mounting jig is not provided as standard. To obtain one, please contact THK.

Models SRG-V, SRG-LV, SRG-R, and SRG-LR

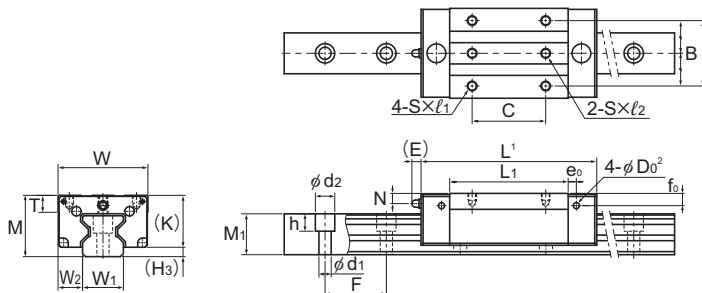

Models SRG15XV and 20X V/LV

Model No.	Outer dimensions			LM block dimensions													Pilot hole for side nipple		
	Height	Width	Length ¹	B	C	S	ℓ	ℓ_1	ℓ_2	L ₁	T	K	N	E	Grease nipple	e ₀	f ₀	D ₀ ²	
	M	W	L																
SRG 15XV SRG 15XGV	24	34	69.2	26	26	M4	—	5	7.5	45	6	20	4	4.5	PB107	4	6	2.9	
SRG 20XV SRG 20XGV	30	44	86.2	32	36	M5	—	7	9	58	8	25.4	5	4.5	PB107	4	6	2.9	
SRG 20XLV SRG 20XGLV	30	44	106.2	32	50	M5	—	7	9	78	8	25.4	5	4.5	PB107	4	6	2.9	
SRG 25XR SRG 25XGR	40	48	95.1	35	35	M6	9	—	—	65.5	9.5	35.5	9.5	12	B-M6F	6	11.3	5.2	
SRG 25XLR SRG 25XGLR	40	48	115.1	35	50	M6	9	—	—	85.5	9.5	35.5	9.5	12	B-M6F	6	11.3	5.2	
SRG 30XR SRG 30XGR	45	60	111	40	40	M8	10	—	—	75	12	40	9.5	12	B-M6F	6	10.5	5.2	
SRG 30XLR SRG 30XGLR	45	60	135	40	60	M8	10	—	—	99	12	40	9.5	12	B-M6F	6	10.5	5.2	

Model number coding

SRG30X	LR	2	QZ	TTHH	C0	+1240L	P	Z	T	-II
Model number	Type of LM block	With QZ Lubricator	Contamination protection accessory symbol	Radial clearance symbol Normal (No symbol) Light preload (C1) Medium preload (C0)	LM rail length (in mm)	Accuracy symbol High accuracy grade (H)/Precision grade (P) Super precision grade (SP)/Ultra precision grade (UP)	With plate cover	Symbol for LM rail jointed use	Symbol for No. of rails used on the same plane	
		No. of LM blocks used on the same rail								

Notes: This model number indicates that a single-rail unit constitutes one set (i.e., required number of sets when 2 rails are used in parallel is 2 at a minimum).

Grease nipples are not installed when there is a QZ Lubricator. Contact THK if you want to use a grease nipple for a model with a QZ. See [A1-547](#) for contamination protection accessories, see [A1-75](#) for radial clearance symbol. See [A1-79](#) for accuracy symbol. See [A1-13](#) for symbol for number of rails used on the same plane.

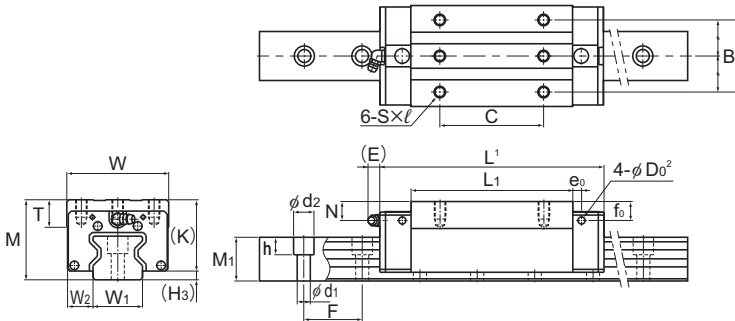

Models SRG25X and 30X R/LR

Unit: mm

H ₃	LM rail dimensions						Basic load rating ¹		Static permissible moment kN·m ⁵					Mass	
	Width W ₁ 0 -0.05	Height W ₂	Pitch M ₁	Pitch F	Length ³ d ₁ × d ₂ × h	Length ³ Max	C kN	C ₀ kN	M _A		M _B		M _C	LM block kg	LM rail kg/m
									1 block	2 blocks	1 block	2 blocks	1 block		
4	15	9.5	15.5	30	4.5 × 7.5 × 5.3	3000	11.3	25.8	0.21	1.24	0.21	1.24	0.24	0.15	1.58
							11.3	30.9	0.25	1.49	0.25	1.49	0.3		
4.6	20	12	20	30	6 × 9.5 × 8.5	3000	21	46.9	0.48	2.74	0.48	2.74	0.58	0.28	2.58
							20.6	54.4	0.56	3.25	0.56	3.25	0.68		
4.6	20	12	20	30	6 × 9.5 × 8.5	3000	26.7	63.8	0.88	4.49	0.88	4.49	0.79	0.38	2.58
							25.9	73.1	0.99	5.27	0.99	5.27	0.91		
4.5	23	12.5	23	30	7 × 11 × 9	3000	27.9	57.5	0.64	3.7	0.64	3.7	0.8	0.6	3.6
							26.7	65	0.76	4.31	0.76	4.31	0.9		
4.5	23	12.5	23	30	7 × 11 × 9	3000	34.2	75	1.07	5.74	1.07	5.74	1.03	0.8	3.6
							32.9	85	1.27	6.69	1.27	6.69	1.18		
5	28	16	26	40	9 × 14 × 12	3000	39.3	82.5	1.02	6.21	1.02	6.21	1.47	0.9	4.4
							38.7	96.9	1.23	7.25	1.23	7.25	1.62		
5	28	16	26	40	9 × 14 × 12	3000	48.3	108	1.76	9.73	1.76	9.73	1.92	1.2	4.4
							47.4	126	2.04	11.3	2.04	11.3	2.11		

¹ Length L shown in the table is the length with the contamination protection accessories, code UU or SS.
If other contamination protection accessories or lubricant equipment are installed, the total block length will increase. (See [A1-521](#) or [A1-543](#))

² D₀ are the pilot holes for when a grease nipple is desired for a product with LaCS or a QZ Lubricator.
Pilot holes are not drilled through for models other than those stated above.
For grease nipple mount machining, contact THK.

³ The maximum length indicates the standard maximum length of an LM rail. (See [A1-438](#).)

⁴ The basic dynamic load rating of the roller guide is a value based on a nominal life of 100 km.
The conversion to basic dynamic load rating for a nominal life of 50 km can be obtained from the following equation.

$$C_{50} = C \times 1.23$$

C₅₀ : The basic dynamic load rating for a nominal load of 50 km

C : The basic dynamic load rating in the dimensional table

⁵ Static permissible moment 1 block: the static permissible moment with one LM block
2 blocks: the static permissible moment with two LM blocks in close contact with each other

Notes: The SRG-G is a cageless, Full-Roller type.

For oil lubrication, be certain to let THK know the mounting orientation and where the LM block piping joint should be attached.
(Mounting orientation: see [A1-12](#), Lubricant: see [A24-2](#))

The removing/mounting jig is not provided as standard. To obtain one, please contact THK.

Models SRG-R, SRG-LR, and SRG-SLR

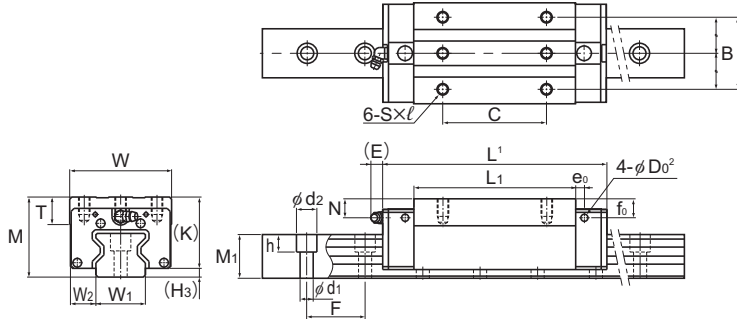

Models SRG35 and 45 R/LR

Model No.	Outer dimensions			LM block dimensions										Pilot hole for side nipple		
	Height	Width	Length ¹	B	C	S	ℓ	L ₁	T	K	N	E	Grease nipple	e ₀	f ₀	D ₀ ²
	M	W	L													
SRG 35R SRG 35GR	55	70	125	50	50	M8	12	82.2	18.5	49	13.5	12	B-M6F	6	13	5.2
SRG 35LR SRG 35GLR	55	70	155	50	72	M8	12	112.2	18.5	49	13.5	12	B-M6F	6	13	5.2
SRG 35SLR SRG 35GSLR	55	70	180.8	50	100	M8	12	138	18.5	49	13.5	12	B-M6F	6	13	5.2
SRG 45R SRG 45GR	70	86	155	60	60	M10	20	107	24.5	62	20	16	B-PT1/8	7	17	5.2
SRG 45LR SRG 45GLR	70	86	190	60	80	M10	20	142	24.5	62	20	16	B-PT1/8	7	17	5.2
SRG 45SLR SRG 45GSLR	70	86	231.5	60	120	M10	20	183.5	24.5	62	20	16	B-PT1/8	7	17	5.2

Model number coding

SRG45 LR 2 QZ TTHH C0 +1200L P Z T - II

Model number

Type of LM block

With QZ Lubricator

Contamination protection accessory symbol

LM rail length (in mm)

With plate cover

Symbol for No. of rails used on the same plane

No. of LM blocks used on the same rail

Radial clearance symbol
Normal (No symbol)
Light preload (C1)
Medium preload (C0)

Accuracy symbol
High accuracy grade (H)/Precision grade (P)
Super precision grade (SP)/Ultra precision grade (UP)

Symbol for LM rail jointed use

Notes: This model number indicates that a single-rail unit constitutes one set (i.e., required number of sets when 2 rails are used in parallel is 2 at a minimum).

Grease nipples are not installed when there is a QZ Lubricator. Contact THK if you want to use a grease nipple for a model with a QZ. See **■1-547** for contamination protection accessories, see **■1-75** for radial clearance symbol. See **■1-79** for accuracy symbol. See **■1-13** for symbol for number of rails used on the same plane.

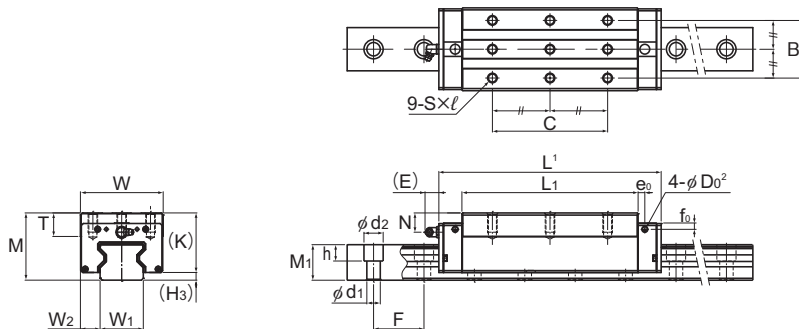

Models SRG35 and 45 SLR

Unit: mm

H ₃	LM rail dimensions							Basic load rating ¹⁾		Static permissible moment kN·m ⁵⁾					Mass	
	W ₁ 0 -0.05	W ₂	M ₁	F	d ₁ × d ₂ × h	Length ³⁾ Max	C kN	C ₀ kN	M _A		M _B		M _C	LM block kg	LM rail kg/m	
									1 block	2 blocks	1 block	2 blocks	1 block			
6	34	18	30	40	9 × 14 × 12	3000	59.1	119	1.66	10.1	1.66	10.1	2.39	1.6	6.9	
							55.3	131	1.77	11.1	1.77	11.1	2.69			
6	34	18	30	40	9 × 14 × 12	3000	76	165	3.13	17	3.13	17	3.31	2.1	6.9	
							71.4	182	3.39	18.8	3.39	18.8	3.74			
6	34	18	30	40	9 × 14 × 12	3000	87.9	199	4.53	23.9	4.53	23.9	4.09	2.6	6.9	
							83.4	222	5	26.6	5	26.6	4.56			
8	45	20.5	37	52.5	14 × 20 × 17	3090	91.9	192	3.49	20	3.49	20	4.98	3.2	11.6	
							87.8	216	3.9	22.5	3.9	22.5	5.87			
8	45	20.5	37	52.5	14 × 20 × 17	3090	115	256	6.13	32.2	6.13	32.2	6.64	4.1	11.6	
							110	288	6.87	36.3	6.87	36.3	7.83			
8	45	20.5	37	52.5	14 × 20 × 17	3090	139	328	9.99	50	9.99	50	8.91	5.4	11.6	
							133	368	11.1	56	11.1	56	10			

¹⁾ Length L shown in the table is the length with the contamination protection accessories, code UU or SS.
If other contamination protection accessories or lubricant equipment are installed, the total block length will increase. (See [A1-521](#) or [A1-543](#))

²⁾ D₀ are the pilot holes for when a grease nipple is desired for a product with LaCS or a QZ Lubricator.
Pilot holes are not drilled through for models other than those stated above.
For grease nipple mount machining, contact THK.

³⁾ The maximum length indicates the standard maximum length of an LM rail. (See [A1-438](#).)

⁴⁾ The basic dynamic load rating of the roller guide is a value based on a nominal life of 100 km.
The conversion to basic dynamic load rating for a nominal life of 50 km can be obtained from the following equation.

$$C_{50} = C \times 1.23$$

C₅₀ : The basic dynamic load rating for a nominal load of 50 km
C : The basic dynamic load rating in the dimensional table

⁵⁾ Static permissible moment
1 block: the static permissible moment with one LM block
2 blocks: the static permissible moment with two LM blocks in close contact with each other

Notes: The SRG-G is a cageless, Full-Roller type.

For oil lubrication, be certain to let THK know the mounting orientation and where the LM block piping joint should be attached.
(Mounting orientation: see [A1-12](#), Lubricant: see [A24-2](#))

The removing/mounting jig is not provided as standard. To obtain one, please contact THK.

Models SRG-V, SRG-LV, SRG-SLV, SRG-R, SRG-LR, and SRG-SLR

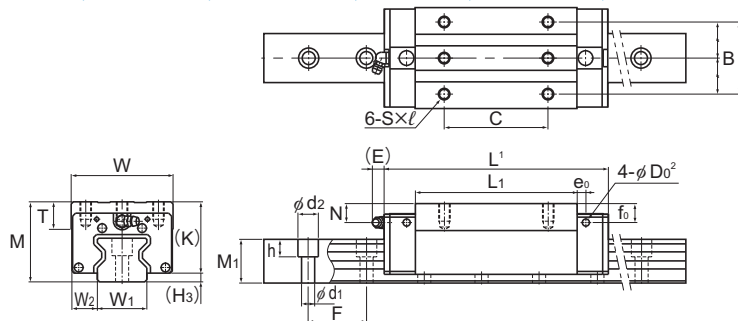

Models SRG55R/LR and 65V/LV

Model No.	Outer dimensions			LM block dimensions										Pilot hole for side nipple		
	Height	Width	Length ¹	B	C	S	ℓ	L ₁	T	K	N	E	Grease nipple	e ₀	f ₀	D ₀ ²
	M	W	L													
SRG 55R SRG 55GR	80	100	185	75	75	M12	18	129.2	27.5	70	22	16	B-PT1/8	9	18.5	5.2
SRG 55LR SRG 55GLR	80	100	235	75	95	M12	18	179.2	27.5	70	22	16	B-PT1/8	9	18.5	5.2
SRG 55SLR SRG 55GSLR	80	100	292	75	150	M12	18	236.2	27.5	70	22	16	B-PT1/8	9	18.5	5.2
SRG 65V SRG 65GV	90	126	244.9	76	70	M16	20	171.7	19.5	78.5	17	16	B-PT1/8	9	13.5	5.2
SRG 65LV SRG 65GLV	90	126	303	76	120	M16	20	229.8	19.5	78.5	17	16	B-PT1/8	9	13.5	5.2
SRG 65SLV SRG 65GSLV	90	126	380	76	200	M16	20	306.8	19.5	78.5	17	16	B-PT1/8	9	13.5	5.2

Model number coding

SRG65 LV 2 QZ TTHH C0 +1270L P Z T - II

Model number

Type of LM block

With QZ Lubricator

Contamination protection accessory symbol

LM rail length (in mm)

With plate cover

Symbol for No. of rails used on the same plane

No. of LM blocks used on the same rail

Radial clearance symbol
Normal (No symbol)
Light preload (C1)
Medium preload (C0)

Accuracy symbol
High accuracy grade (H)/Precision grade (P)
Super precision grade (SP)/Ultra precision grade (UP)

Symbol for LM rail jointed use

Notes: This model number indicates that a single-rail unit constitutes one set (i.e., required number of sets when 2 rails are used in parallel is 2 at a minimum).

Grease nipples are not installed when there is a QZ Lubricator. Contact THK if you want to use a grease nipple for a model with a QZ. See **■1-547** for contamination protection accessories, see **■1-75** for radial clearance symbol. See **■1-79** for accuracy symbol. See **■1-13** for symbol for number of rails used on the same plane.

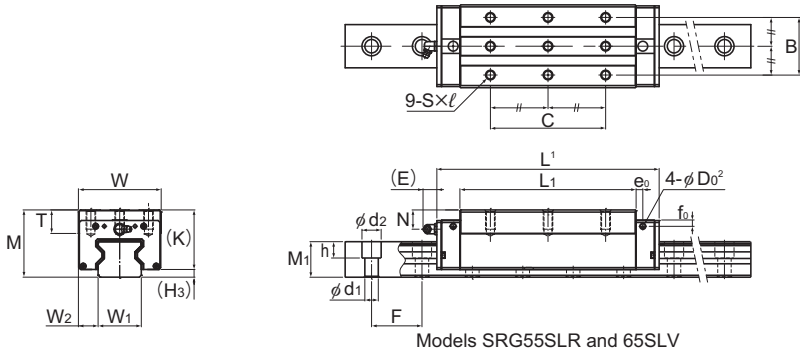

Unit: mm

H ₃	LM rail dimensions							Basic load rating ¹⁾		Static permissible moment kN·m ⁵⁾					Mass	
	W ₁ 0 -0.05	W ₂	M ₁	F	d ₁ × d ₂ × h	Length ³⁾ Max	C	C ₀	M _A		M _B		M _C	LM block kg	LM rail kg/m	
									1 block	2 blocks	1 block	2 blocks				1 block
10	53	23.5	43	60	16 × 23 × 20	3060	131	266	5.82	33	5.82	33	8.19	5	15.8	
							125	300	6.5	37.2	6.5	37.2	9.55			
10	53	23.5	43	60	16 × 23 × 20	3060	167	366	10.8	57	10.8	57	11.2	6.9	15.8	
							160	411	12.1	64	12.1	64	13.1			
10	53	23.5	43	60	16 × 23 × 20	3060	210	488	19.1	93.7	19.1	93.7	15.6	9.2	15.8	
							199	544	21	104	21	104	17.3			
11.5	63	31.5	54	75	18 × 26 × 22	3000	219	441	12.5	72.8	12.5	72.8	16.8	9	23.7	
							214	511	14.8	83.8	14.8	83.8	19.4			
11.5	63	31.5	54	75	18 × 26 × 22	3000	278	599	22.7	120	22.7	120	22.1	12.1	23.7	
							264	670	25.3	135	25.3	135	25.5			
11.5	63	31.5	54	75	18 × 26 × 22	3000	352	811	41.3	202	41.3	202	30.9	16.1	23.7	
							332	899	45.2	224	45.2	224	25.6			

¹⁾ Length L shown in the table is the length with the contamination protection accessories, code UU or SS.

If other contamination protection accessories or lubricant equipment are installed, the total block length will increase. (See [A1-521](#) or [A1-543](#))

²⁾ D₀ are the pilot holes for when a grease nipple is desired for a product with LaCS or a QZ Lubricator.

Pilot holes are not drilled through for models other than those stated above.

For grease nipple mount machining, contact THK.

³⁾ The maximum length indicates the standard maximum length of an LM rail. (See [A1-438](#).)

⁴⁾ The basic dynamic load rating of the roller guide is a value based on a nominal life of 100 km.

The conversion to basic dynamic load rating for a nominal life of 50 km can be obtained from the following equation.

$$C_{50} = C \times 1.23$$

C₅₀ : The basic dynamic load rating for a nominal load of 50 km

C : The basic dynamic load rating in the dimensional table

⁵⁾ Static permissible moment 1 block: the static permissible moment with one LM block

2 blocks: the static permissible moment with two LM blocks in close contact with each other

Notes: The SRG-G is a cageless, Full-Roller type.

For oil lubrication, be certain to let THK know the mounting orientation and where the LM block piping joint should be attached.

(Mounting orientation: see [A1-12](#), Lubricant: see [A1-24-2](#))

The removing/mounting jig is not provided as standard. To obtain one, please contact THK.

Standard Lengths and Maximum Lengths of LM Rails

Table 4 shows the standard lengths and the maximum lengths of model SRG variations. If the maximum length of the desired LM rail exceeds these values, jointed rails will be used. Contact THK for details.

For special rail lengths, it is recommended to use a value corresponding to the G and g dimensions from the table. As the G and g dimensions increase, this portion becomes less stable, and the accuracy performance is severely impacted.

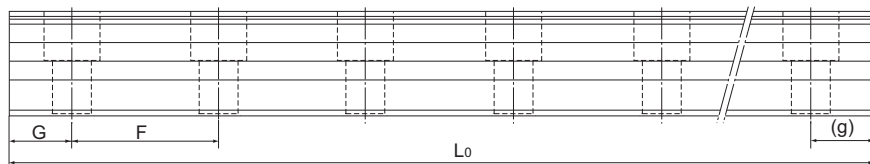

Table 4: Standard Lengths and Maximum Lengths of LM Rails for Model SRG

Unit: mm

Model No.	SRG 15X	SRG 20X	SRG 25X	SRG 30X	SRG 35	SRG 45	SRG 55	SRG 65	SRG 85	SRG 100
LM rail standard lengths (L_0)	160	220	220	280	280	570	780	1270	1530	1340
	220	280	280	360	360	675	900	1570	1890	1760
	280	340	340	440	440	780	1020	2020	2250	2180
	340	400	400	520	520	885	1140	2620	2610	2600
	400	460	460	600	600	990	1260			
	460	520	520	680	680	1095	1380			
	520	580	580	760	760	1200	1500			
	580	640	640	840	840	1305	1620			
	640	700	700	920	920	1410	1740			
	700	760	760	1000	1000	1515	1860			
	760	820	820	1080	1080	1620	1980			
	820	940	940	1160	1160	1725	2100			
	940	1000	1000	1240	1240	1830	2220			
	1000	1060	1060	1320	1320	1935	2340			
	1060	1120	1120	1400	1400	2040	2460			
	1120	1180	1180	1480	1480	2145	2580			
	1180	1240	1240	1560	1560	2250	2700			
	1240	1360	1300	1640	1640	2355	2820			
	1360	1480	1360	1720	1720	2460	2940			
	1480	1600	1420	1800	1800	2565	3060			
1600	1720	1480	1880	1880	2670					
	1840	1540	1960	1960	2775					
	1960	1600	2040	2040	2880					
	2080	1720	2200	2200	2985					
	2200	1840	2360	2360	3090					
		1960	2520	2520						
		2080	2680	2680						
		2200	2840	2840						
		2320	3000	3000						
		2440								
Standard pitch F	30	30	30	40	40	52.5	60	75	90	105
G, g	20	20	20	20	20	22.5	30	35	45	40
Max length	3000	3000	3000	3000	3000	3090	3060	3000	3000	3000

Notes: The maximum length varies with accuracy grades. Contact THK for details.

If jointed rails are not allowed and a greater length than the maximum values above is required, contact THK.

Tapped-Hole Type LM Rail

Model SRG rails also include a type where the LM rail is tapped from the bottom. This type is useful when mounting from the bottom of the base and when increased contamination protection is desired.

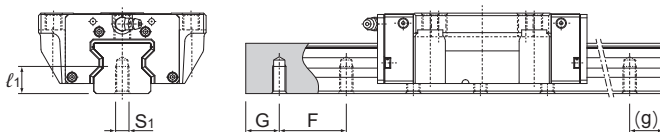

- (1) A tapped-hole LM rail is available only for products of Precision grade accuracy or lower.
- (2) For standard pitches of the taps and the G and g dimensions, see **A1-438** on Table 4.

Table 5: Dimensions of the LM Rail Tap

Unit: mm

Model No.	S ₁	Effective tap depth l_1
SRG 15X	M4	8
SRG 20X	M5	10
SRG 25X	M6	12
SRG 30X	M8	16
SRG 35	M8	16
SRG 45	M12	24
SRG 55	M14	28
SRG 65	M16	32

Model number coding

SRG30XC2UU+1000LP K

Symbol for
tapped-hole LM rail type

Plate Cover

By covering the LM rail's mounting holes with ultra-thin stainless steel (SUS304) plates, the adhesion of the end seals increases drastically, helping prevent foreign materials and liquid from entering from the top of the LM rail. Contact THK for further details regarding mounting.

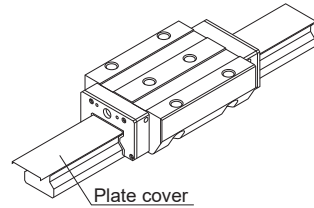

Notes: The plate cover is not a standard specification for Model SRG. (Please note it is not possible to add just the plate cover afterwards.)
 The LM block must be removed from the LM rail when mounting. When doing this, a removing/mounting jig (see [A1-575](#)) is required. Please contact THK for details.
 Plate covers are available for models SRG 25X to 65.
 Plate covers cannot be used in combination with a tapped-hole LM rail.

Lubrication Hole

Lubrication Hole for Model SRG

Model SRG allows lubrication from both the side and top faces of the LM block. The lubrication hole of standard types is not drilled through in order to prevent foreign material from entering the LM block. When using the lubrication hole, contact THK.

When using the lubrication hole on the top face of models SRG-R/LR/SLR, a separate lubrication adapter is required. Contact THK for details.

The lubricant may not reach the raceway if the LM Guide is not installed in a horizontal orientation.

Be sure to let THK know the mounting orientation and the exact position in each LM block where the grease nipple or the piping joint should be attached.

For the mounting orientation and the lubrication, see [A1-12](#) and [A24-2](#), respectively.

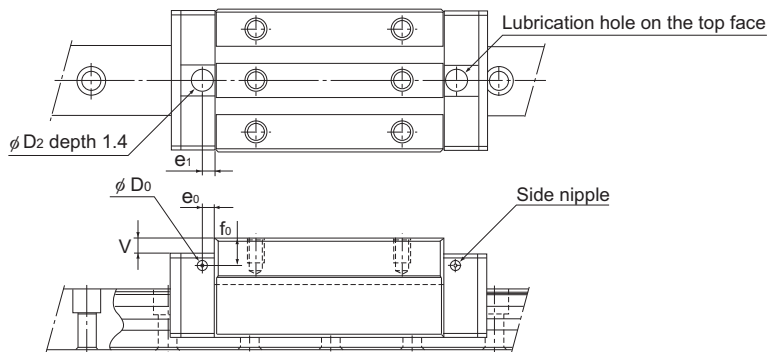

Unit: mm

Model No.	Pilot hole for side nipple			Applicable nipple	Lubrication hole on the top face				
	e_0	f_0	D_0		D_2	(O-ring)	V	e_1	
SRG	15XA 15XV	4	6	2.9	PB107	9.2	(P6)	0.4	5.5
	20XA 20XLA	4	6	2.9	PB107	9.2	(P6)	0.4	6.5
	20XV 20XLV	4	6	2.9	PB107	9.2	(P6)	0.4	6.5
	25XC 25XLC	6	7.3	5.2	M6F	10.2	(P7)	0.4	6
	25XR 25XLR	6	11.3	5.2	M6F	10.2	(P7)	4.5	6
	30XC 30XLC	6	7.5	5.2	M6F	10.2	(P7)	0.4	6
	30XR 30XLR	6	10.5	5.2	M6F	10.2	(P7)	3.4	6
	35C 35LC 35SLC	6	6	5.2	M6F	10.2	(P7)	0.4	6
	35R 35LR 35SLR	6	13	5.2	M6F	10.2	(P7)	7.4	6
	45C 45LC 45SLC	7	7	5.2	M6F	10.2	(P7)	0.4	7
	45R 45LR 45SLR	7	17	5.2	M6F	10.2	(P7)	10.4	7
	55C 55LC 55SLC	9	8.5	5.2	M6F	10.2	(P7)	0.4	11
	55R 55LR 55SLR	9	18.5	5.2	M6F	10.2	(P7)	10.4	11
	65C 65LC 65SLC	9	13.5	5.2	M6F	10.2	(P7)	0.4	10
	65V 65LV 65SLV	9	13.5	5.2	M6F	10.2	(P7)	0.4	10
	85LC	15	22	8.2	PT1/8	13	(P10)	0.4	10
	100LC	15	23	8.2	PT1/8	13	(P10)	0.4	10

Note: Upper surface lubrication is oil lubrication only. Contact THK if you are considering using the lubrication hole on the top face for grease lubrication.