

MX

Miniature Cross LM Guide Model MX

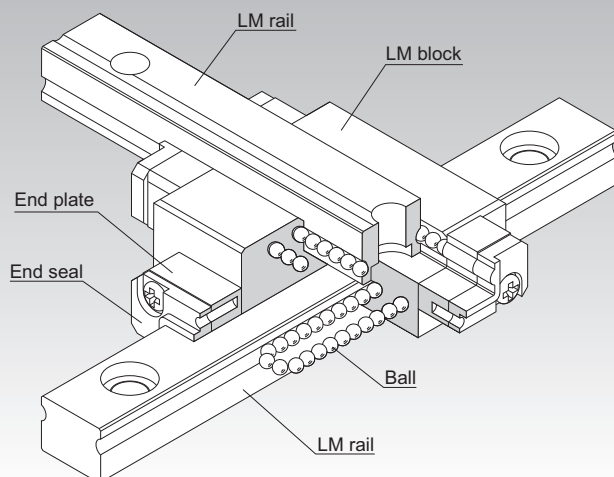

Selection Criteria **A1-10**

Design Highlights **A1-482**

Options **A1-507**

Model No. **A1-577**

Handling Precautions **A1-583**

Accessories for Lubrication **A24-1**

Mounting Procedure **B1-89**

Equivalent Moment Factor **A1-43**

Rated Loads in All Directions **A1-61**

Equivalent Factor in Each Direction **A1-63**

Radial Clearance **A1-74**

Accuracy Standards **A1-86**

Shoulder Height of the Mounting Base and the Corner Radius **A1-492**

Dimensions of Each Model with Options Attached **A1-521**

Structure and Features

Balls roll in two rows of raceways precision-ground on an LM rail and an LM block, and end plates incorporated in the LM block allow the balls to circulate. This model has two Miniature LM Guide Model RSR rails intersecting at right angles integrated back-to-back into a single block. The Model MX alone achieves an extremely low-profile orthogonal LM System, eliminating the need for conventional saddles and enabling a more compact structure.

4-Way Equal Load

Each row of balls is placed at a contact angle of 45° so that the load ratings applied to the LM block are uniform in the four directions (radial, reverse-radial, and lateral directions), enabling the LM Guide to be used in all orientations.

LM Rail with Tapped Holes

There are two types of the LM rail: one designed to be mounted from the top with bolts, and a semi-standard type whose bottom face has tapped holes, allowing the rail to be mounted from the bottom.

Types and Features

Model MX

Model MX is divided into two types: RSR5 cross type and RSR7W cross type.

Dimensional Table \Rightarrow **A1-322**

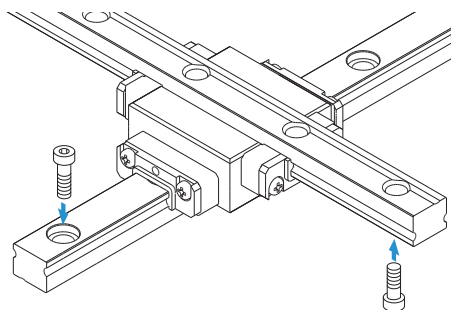

Model MX

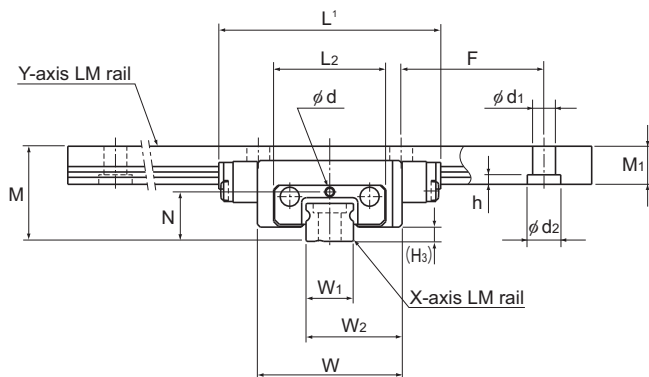

Model No.	Outer dimensions			LM block dimensions			H ₃
	Height	Width	Length ¹	L ₂	N	Lubrication hole d	
	M	W	L				
MX 5M	10	15.2	23.3	11.8	5.2	0.8	1.5
MX 7WM	14.5	30.2	40.8	24.6	7.4	1.2	2

Model number coding

4	MX7W	M	UU	C1	+140L	P	M / 110L	P	T	M
Total No. of LM blocks	Model number		Contamination protection accessory symbol	Radial clearance symbol Normal (No symbol) Light preload (C1)	LM rail length on the X axis (in mm)	LM rail is made of stainless steel	LM rail length on the Y axis (in mm)	LM rail is made of stainless steel	Symbol for LM rail jointed use	LM rail is made of stainless steel
								Accuracy symbol Normal grade (No Symbol) Precision grade (P)		

Notes: See contamination protection accessories on [A1-547](#). See [A1-74](#) for radial clearance symbol. See [A1-86](#) for accuracy symbol.

If the product is of the semi-standard type that uses tapped holes in the LM rail for mounting, include a "K" in the model number after the accuracy symbol.

Example: 4MX7WMUUC1+120LP K M/100LP K TM

└──────────┘ Add symbol "K"

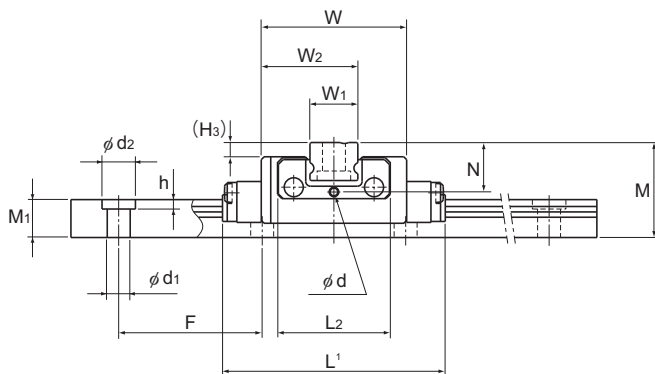

Unit: mm

LM rail dimensions						Basic load rating		Static permissible moment ² N·m		Mass	
Width		Height	Pitch		Length ²	C	C ₀	M ₀	M _B	LM block	LM rail
W ₁	W ₂	M ₁	F	d ₁ × d ₂ × h	Max	kN	kN			kg	kg/m
5 ⁰ _{-0.02}	10.1	4	15	2.4 × 3.5 × 1	200	0.59	1.1	2.57	2.57	0.01	0.14
14 ⁰ _{-0.025}	22.1	5.2	30	3.5 × 6 × 3.2	400	2.04	3.21	14.7	14.7	0.051	0.51

¹ Length L shown in the table is the length with the contamination protection accessories (code: UU).

² The maximum length indicates the standard maximum length of an LM rail. (See **A1-324**.)

³ Static permissible moment 1 block: the static permissible moment with one LM block

Notes: Since stainless steel is used in the LM block, LM rail, and balls, these models are highly resistant to corrosion and environment. Please be aware that the balls will fall out of the LM block if it is removed from the LM rail.

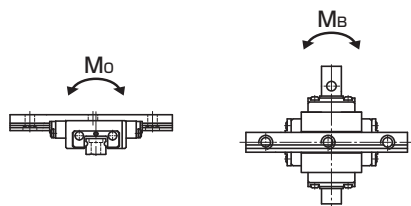

For the LM rail mounting holes, a semi-standard type with tapped holes in the LM rail is also available.

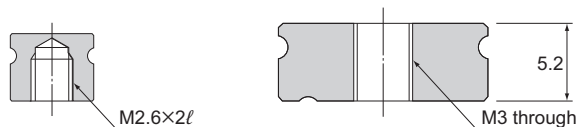

Model MX5M

Model MX7WM

When mounting the LM rail of model MX7WM, take into account the thread length of the mounting bolt in order to prevent the bolt end from sticking out of the top face of the LM rail.

Standard Lengths and Maximum Lengths of LM Rails

Table 1 shows the standard lengths and the maximum lengths of model MX variations.

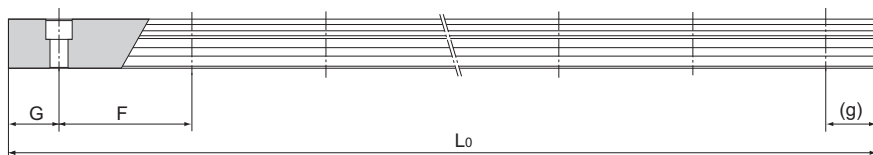

Table 1: Standard Lengths and Maximum Lengths of LM Rails for Model MX

Unit: mm

Model No.	MX 5	MX 7W
LM rail standard lengths (L_0)	40	50
	55	80
	70	110
	100	140
	130	170
	160	200
		260
Standard pitch F	15	30
G, g	5	10
Max length	200	400

Note: The maximum length varies with accuracy grades. Contact THK for details.

