

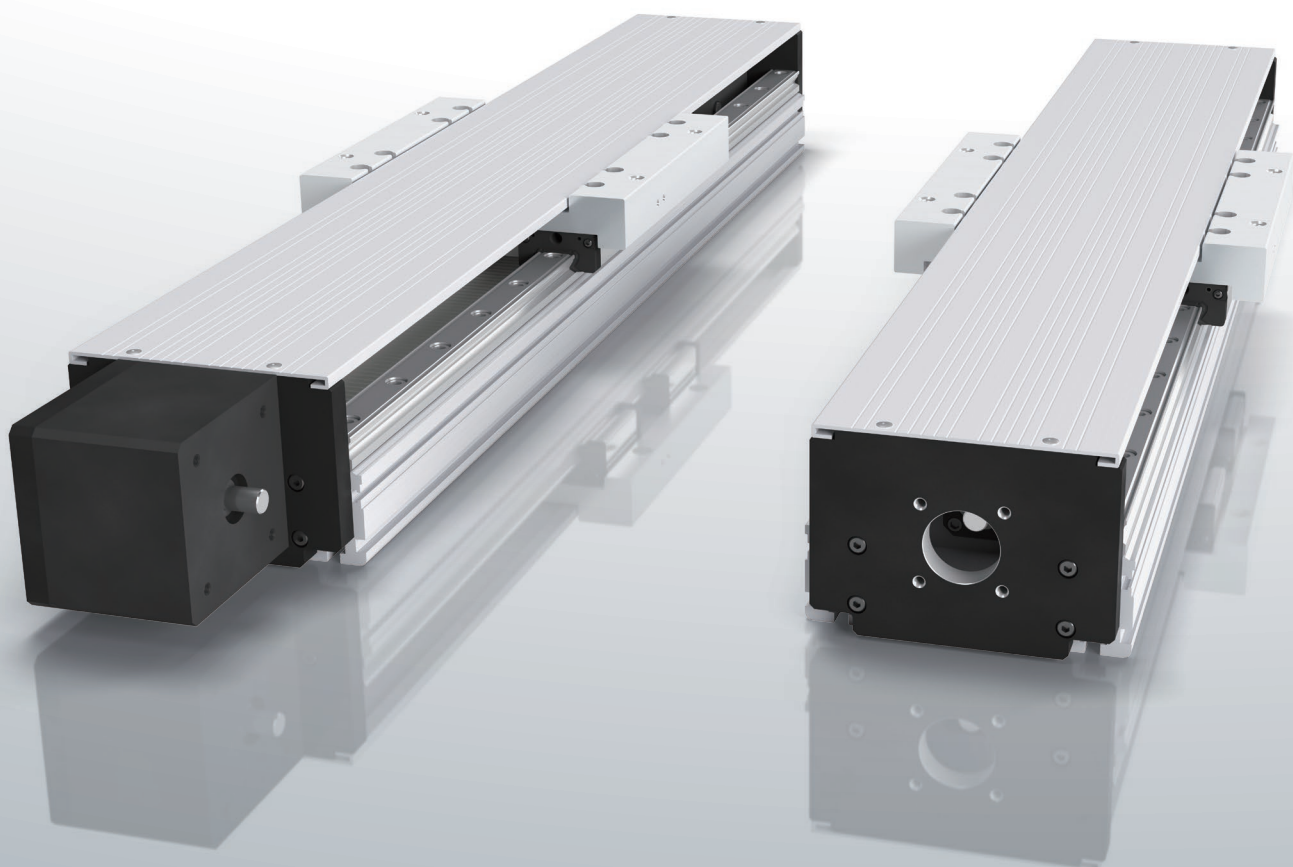

Universal Series Electric Actuator

GL-N



Highly rigid actuators
with an aluminum base suited
for transferring heavy objects

Electric Actuator

GL-N

GL-N

A lightweight, highly rigid electric actuator with an aluminum base

The Universal Series GL-N is an electric actuator with a central ball screw shaft surrounded on both sides by LM Guide units. Combined with an aluminum base designed for rigidity, this product offers many benefits.

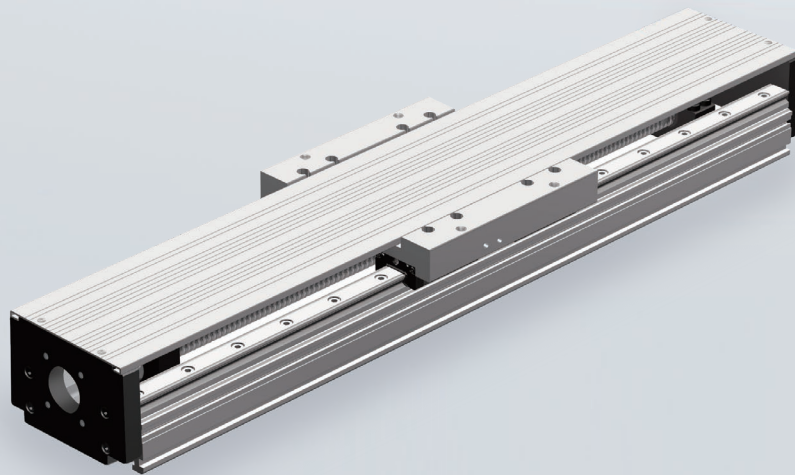

Ball screw type
Direct coupling specification

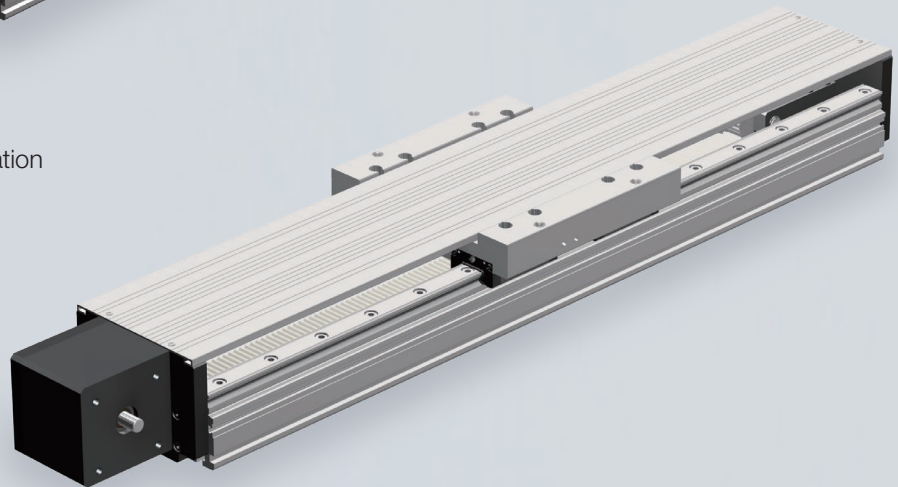

Belt-driven type

The GL-N is available with two drive options.

Based on your application, you can select a ball screw type, which is optimal for transporting heavy objects, or a belt-driven type, which is best suited for high-speed transfers over long strokes.

Ball screw type

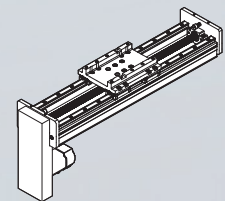
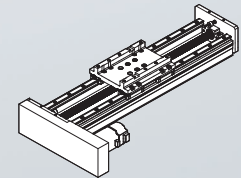
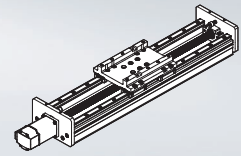
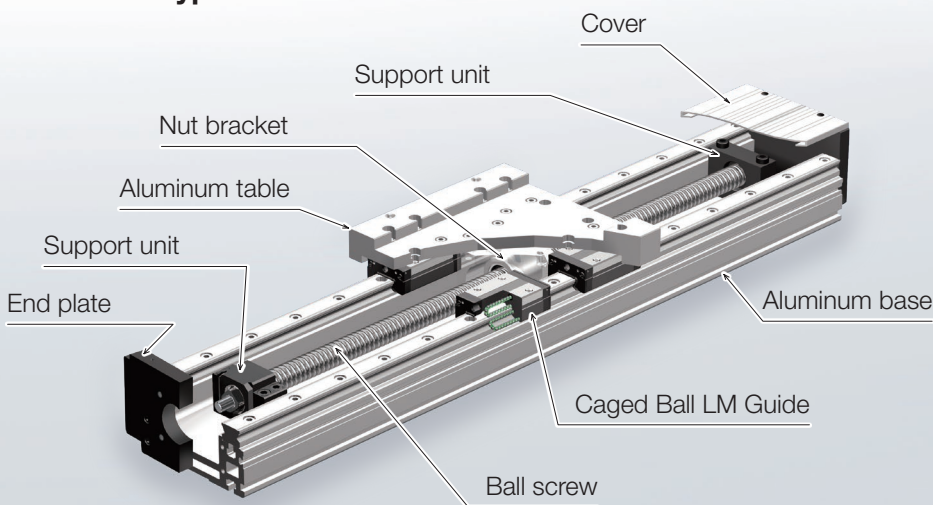

Belt-driven type

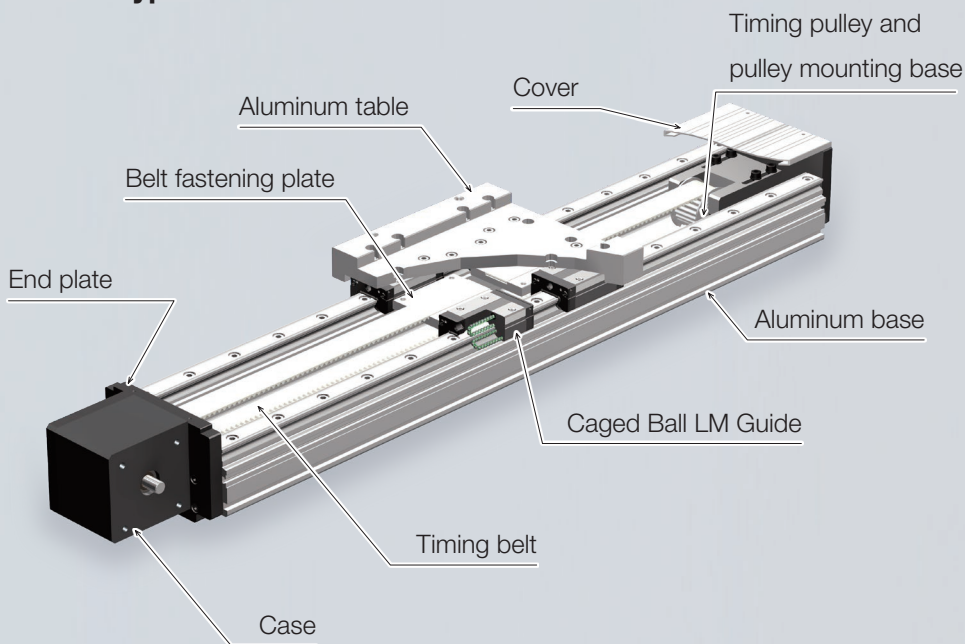

Note: The belt-driven type is intended for horizontal use. Please be aware that it cannot be used vertically. In addition, contact THK if you will be mounting the product on a wall.

An electric actuator featuring Caged Ball LM Guide units and a lightweight, highly rigid aluminum base

Feature 1

Multiple Options Available for the LM Guide Units

The GL-N uses two Caged Ball LM Guide units, which makes it suited for transferring heavy objects.

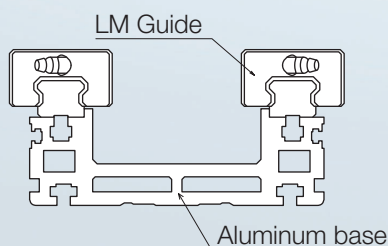

SSR: The ball contact structure is resistant to loads in the radial direction, making this type of guide ideal for horizontal use.

SHS: This type of guide bears loads equally in four directions, so loads can be applied from any direction (radial, reverse radial, and horizontal).

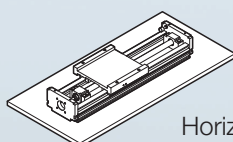

Horizontal

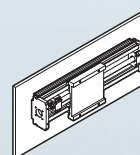

Wall-mounted

Note: The belt-driven type is intended for horizontal use.

Feature 2

Optimal for High-Speed Transfers over Long Strokes

GL-N actuators feature an aluminum base and are suited for transferring objects over long strokes.

- Ball screw type

The ball screw has a wide variety of lead options. This type can operate up to speeds of 2,000 mm/s.

Max. speed
2,000 mm/s

* When using GL20N

- Belt-driven type

A timing belt is used as the drive method. This type can operate at speeds up to 2,000 m/s.

Max. speed
2,000 mm/s

* When using GL20N

Ball Screw Leads by Model (Rolled Ball Screws)

Model	Ball screw lead (mm)	Stroke (mm)	Max. speed (mm/s)
GL15N	5, 10, 16, 20, 30	Up to 1,190	1,500
GL20N	5, 10, 20, 40	Up to 1,540	2,000

Feature 3

Lightweight and Highly Rigid

The cross-section of the extruded aluminum base features hollow areas, making it both lightweight and highly rigid.

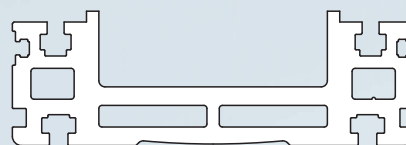

Feature 4

Many Accessories Available

Optional covers, bellows, sensors, and cable carriers are available. A QZ Lubricator can be attached to the LM Guide and ball screw units to enable long-term maintenance-free operation.

Optimal for transferring heavy objects and moving at high speeds over long strokes

General Industry File Creasing Machines

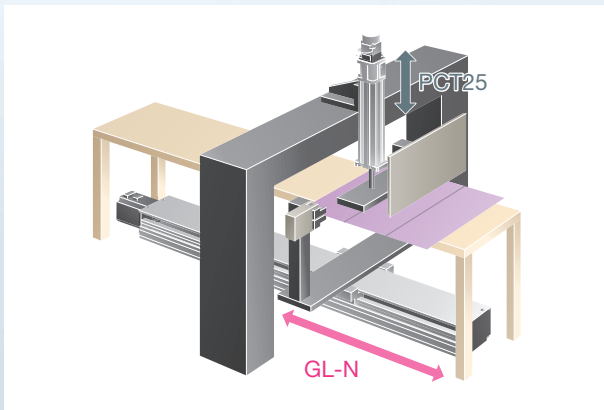

A GL-N is used for the mechanism that feeds file folders into the machine. A single machine can make multiple kinds of file folders, so the GL-N is ideal for its high positioning repeatability.

(Ball screw type)

Model used	Horizontal axis: GL15N Vertical axis: PCT25
------------	--

General Industry Contour Measurement Machines

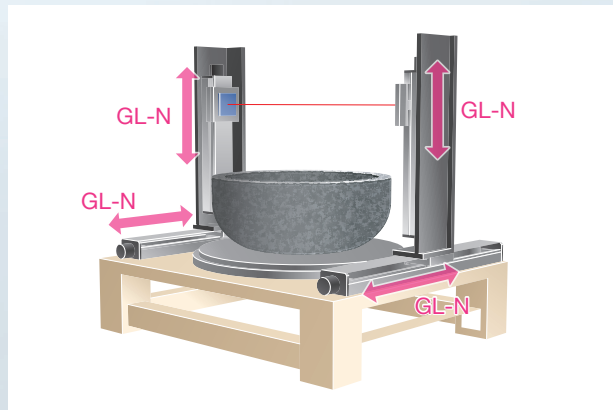

GL-N units are used in machines that measure an object's height and external dimensions. The traditional LM Guide and ball screw combination now comes as a single unit, which reduces equipment design and assembly time.

(Ball screw type)

Model used	Vertical axis: GL15N Horizontal axis: GL20N
------------	--

Pharmaceutical and Food Industries Cellular Analysis Equipment

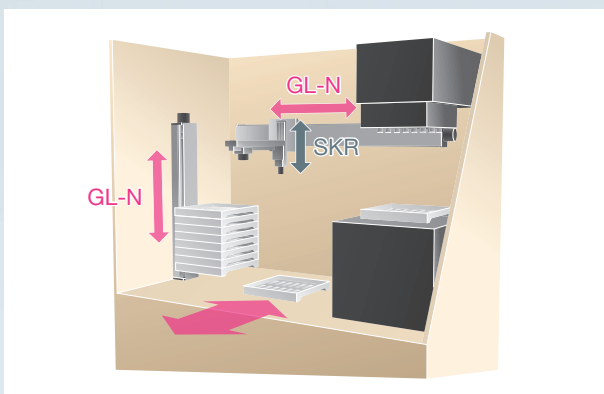

GL-N and SKR units are used in the handling mechanisms of inspection equipment. They enable smooth movement and high positioning repeatability for the handling of fragile glass plates.

(Ball screw type)

Model used	Vertical axis: GL20N Horizontal axis: GL15N Vertical axis: SKR26
------------	--

General Industry Welding Machines

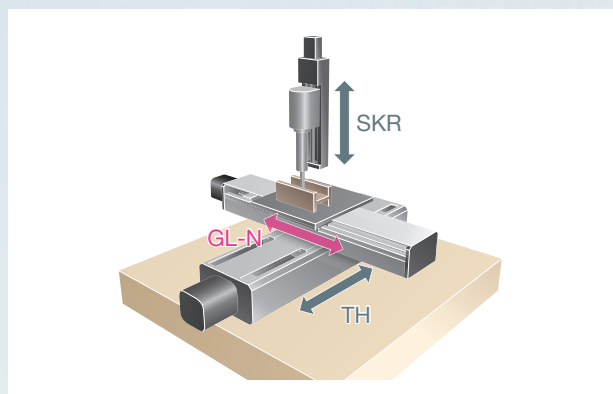

GL-N and TH units are used in the parts of welders that move workpieces. These products boast high positioning repeatability that has improved welding position accuracy.

(Ball screw type)

Model used	X axis: TH20 Y axis: GL15N Z axis: SKR33
------------	--

Series Overview (Ball Screw Type)

Model	Ball screw lead (mm)	Stroke ¹ (mm)	Estimated motor capacity (W)	Maximum load capacity ² (kg)		
				Horizontal	Wall-mounted	Vertical
GL15N	5	110 to 1,190	100	60	60	13
	10			60	60	16
	16		200	50	50	7
	20			45	45	10
	20			60	60	16
30	400	30	30	10		
40		70	70	23		
GL20N	5	220 to 1,540	200	70	70	15
	10			29	29	6
	20		400	60	60	15
	20			13	13	6
	40					

¹ Stroke values are when using an S table.

² Maximum load capacity refers to the mass at the rated speed and an acceleration/deceleration of 0.3 G (0.15 G only when lead is 5 mm).

³ The maximum speed is restricted by the permissible speed of the actuator.

Series Overview (Belt-Driven Type)

Model	Drive system	Stroke ⁴ (mm)	Estimated motor capacity (W)	Maximum load capacity ⁵ (kg)	
				Horizontal	Vertical
GL15N	Belt	315 to 1,695	200	12	
			400	25	
GL20N		280 to 2,700	200	9.5	
			400	20	

⁴ Stroke values are when using an S table.

⁵ The maximum load capacity refers to the mass at the rated speed and an acceleration/deceleration of 0.3 G.

⁶ Rated speed refers to the speed at the rated rotational speed of the motor (3,000 min⁻¹).

Model Number Coding (Ball Screw Type)

Model	Stroke	LM Guide model	LM Guide with/without QZ	Ball screw lead	Ball screw with/without QZ	With/without motor	End plate/motor mounting plate	Cover/bellows	Sensor	Cable carrier
①	②	③	④	⑤	⑥	⑦	⑧	⑨	⑩	⑪
GL15N	980	SW	Q	B20	Q	0	B14	C	6	J
GL15N	0090: 90 mm	SV: SSR-XV	No symbol: Without QZ	B05: 5 mm	No symbol: Without QZ	With direct coupling	With direct coupling	N: Uncovered	N: None	N: None
GL20N	to	SV: SSR-XW	Q: With QZ	B10: 10 mm	Q: With QZ	0: Without motor (Without coupling. If necessary, please specify.)	A	C: Covered	2	A
	1540: 1,540 mm	HV: SHS-V		B16: 16 mm		1: With motor (THK will purchase and mount the motor you specify.)	B	J: With bellows	3	B
				B20: 20 mm		With motor wrap	E		6	C
				B30: 30 mm		R1: Non-standard side wrap (without motor)	F		G	D
				B40: 40 mm		R2: Standard side wrap (without motor)	H			E
						R3: Bottom-side wrap (without motor)	I			F
						R4: Non-standard side wrap (THK will purchase and mount the motor you specify.)	With motor wrap			G
						R5: Standard side wrap (THK will purchase and mount the motor you specify.)	B14			H
						R6: Bottom-side wrap (THK will purchase and mount the motor you specify.)	F11			I
							F14			J

When "J" (with bellows) is selected for ⑨ Cover/bellows, specify the stroke with bellows. → p. 23, p. 41

Please select one of the combinations below.

Table type	③ LM Guide model	④ LM Guide with/without QZ	⑤ Ball screw lead	⑥ Ball screw with/without QZ
S table	SV	No symbol: Without QZ	B□□	No symbol: Without QZ
L table	SW / HV	No symbol: Without QZ	B□□	No symbol: Without QZ
L (QZ)	SW / HV	No symbol: Without QZ	B□□	Q: With QZ
L-QZ	SW / HV	Q: With QZ	B□□	Q: With QZ

The available ball screw lead options vary based on the model.
 GL15N: B05, B10, B16, B20, B30
 GL20N: B05, B10, B20, B40

If "0" is selected:
Coupling not included. Please specify if a coupling is required when ordering.

If "R1," "R2," or "R3" is selected:
The timing pulley and timing belt will be included.

If "1," "R4," "R5," or "R6" is selected:
The designated motor will be mounted. Please specify the motor cable direction separately. Please select the end plate and motor mounting plate in ⑧ that match the specified motor. Please select the coupling, driver, and controller yourself.

This product is compatible with motors from various manufacturers.
Contact THK for details.

	Maximum speed at each stroke ³ (mm/s)															Page	
	Stroke ¹ (mm)																
	100	200	300	400	500	600	700	800	900	1,000	1,100	1,200	1,300	1,400	1,500		1,600
		490			370			200		140		100					p. 7
		740			700			380		260		190					
		1,120						660		460		340					
		1,480			1,390			750		520		380					
		1,480			1,390			750		520		380					
		2,220			2,120			1,140		790		580					p. 25
		400			250			250		180		130	100	80			
		740			700			380		260		190					
		1,120						1,060		740		540	410	330			
		1,120						1,060		740		540	410	330			
		2,240						2,120		1,480		1,090	830	660			

	Maximum speed at each stroke (mm) ⁶ (mm/s)																				Page							
	Stroke ⁴ (mm)																											
	100	200	300	400	500	600	700	800	900	1,000	1,100	1,200	1,300	1,400	1,500	1,600	1,700	1,800	1,900	2,000		2,100	2,200	2,300	2,400	2,500	2,600	2,700
								1,830																				p. 15
								1,830																				
																												p. 33

Model Coding (Belt-Driven Type)

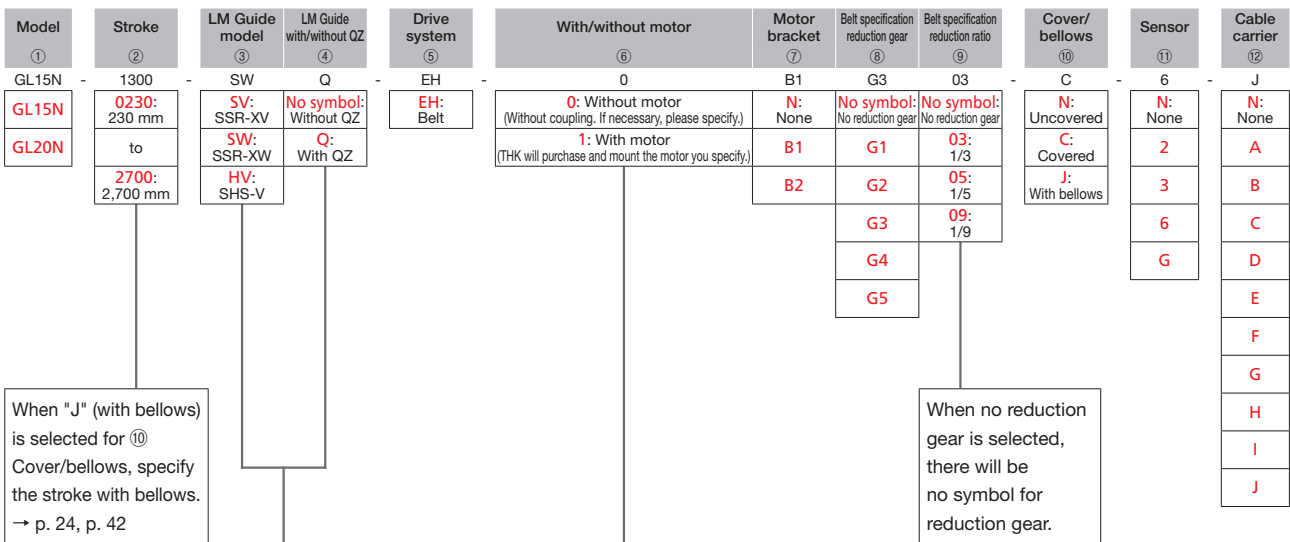

Please select one of the combinations below.

Table type	③ LM Guide model	④ LM Guide with/without QZ
S table	SV	No symbol: Without QZ
L table	SW / HV	No symbol: Without QZ
L-QZ	SW / HV	Q: With QZ

If "0" is selected:
Coupling not included. Please specify if a coupling is required when ordering.

If "1" is selected:
The designated motor and reduction gear will be mounted. Please specify the motor cable direction separately. Please select the motor bracket in ⑦ that matches the specified motor and reduction gear. Please select the coupling, driver, and controller yourself.

This product is compatible with motors from various manufacturers.
Contact THK for details.

GL15N

Direct motor coupling	Motor wrap	Width 154 mm	Height 75.6 mm	Max. stroke 1,190 mm	Max. speed 2,220 mm/s	Ball screw type
-----------------------	------------	--------------	----------------	----------------------	-----------------------	-----------------

Model Number Coding

Model	Stroke	LM Guide model	LM Guide with/without QZ	Ball screw lead	Ball screw with/without QZ	With/without motor																									
①	②	③	④	⑤	⑥	⑦																									
GL15N	990	SW	Q	B20	Q	0																									
GL15N	0090: 90 mm to 1190: 1,190 mm	SV: SSR15XV SW: SSR15XW HV: SHS15V	No symbol: Without QZ Q: With QZ	B05: 5 mm B10: 10 mm B16: 16 mm B20: 20 mm B30: 30 mm	No symbol: Without QZ Q: With QZ	0: Without motor (Without coupling. If necessary, please specify.) 1: With motor (THK will purchase and mount the motor you specify.)																									
<p>When "J" (with bellows) is selected for ⑨ Cover/bellows, specify the stroke with bellows. → p. 23</p>																															
<p>Please select one of the combinations below.</p> <table border="1"> <thead> <tr> <th>Table type</th> <th>③ LM Guide model</th> <th>④ LM Guide with/without QZ</th> <th>⑤ Ball screw lead</th> <th>⑥ Ball screw with/without QZ</th> </tr> </thead> <tbody> <tr> <td>S table</td> <td>SV</td> <td>No symbol: Without QZ</td> <td>B□□</td> <td>No symbol: Without QZ</td> </tr> <tr> <td>L table</td> <td>SW / HV</td> <td>No symbol: Without QZ</td> <td>B□□</td> <td>No symbol: Without QZ</td> </tr> <tr> <td>L (QZ) table</td> <td>SW / HV</td> <td>No symbol: Without QZ</td> <td>B□□</td> <td>Q: With QZ</td> </tr> <tr> <td>L-QZ table</td> <td>SW / HV</td> <td>Q: With QZ</td> <td>B□□</td> <td>Q: With QZ</td> </tr> </tbody> </table>							Table type	③ LM Guide model	④ LM Guide with/without QZ	⑤ Ball screw lead	⑥ Ball screw with/without QZ	S table	SV	No symbol: Without QZ	B□□	No symbol: Without QZ	L table	SW / HV	No symbol: Without QZ	B□□	No symbol: Without QZ	L (QZ) table	SW / HV	No symbol: Without QZ	B□□	Q: With QZ	L-QZ table	SW / HV	Q: With QZ	B□□	Q: With QZ
Table type	③ LM Guide model	④ LM Guide with/without QZ	⑤ Ball screw lead	⑥ Ball screw with/without QZ																											
S table	SV	No symbol: Without QZ	B□□	No symbol: Without QZ																											
L table	SW / HV	No symbol: Without QZ	B□□	No symbol: Without QZ																											
L (QZ) table	SW / HV	No symbol: Without QZ	B□□	Q: With QZ																											
L-QZ table	SW / HV	Q: With QZ	B□□	Q: With QZ																											
<p>If "0" is selected: No coupling will be attached. Please specify if a coupling is required when ordering.</p> <p>If "R1," "R2," or "R3" is selected: The timing pulley and timing belt will be included.</p> <p>If "1," "R4," "R5," or "R6" is selected: The designated motor will be mounted. Please specify the motor cable direction separately. Please select the end plate and motor mounting plate in ⑧ that match the specified motor.</p>																															

Table Type

The block table type is determined by the LM Guide you select. In addition, the stroke range varies depending on the block table type.

- S table Short table (LM Guide model: SSR15XV)
This type has a shorter table to allow for a longer stroke range.
- L table Long table (LM Guide models: SSR15XW, SHS15V)
This type is optimal for high loads or when loads are positioned away from the center of the table.
- L (QZ) table Long table with QZ Lubricator (LM Guide models: SSR15XW, SHS15V)
A QZ Lubricator is attached to the ball screw.
- L-QZ table Long table with QZ Lubricator (LM Guide models: SSR15XWQZ, SHS15VQZ)
A QZ Lubricator is attached to the LM Guide and ball screw. (This table is longer than an L table. See the dimensional tables on p. 9 to 10.)

⑦ With/Without Motor

Motor mounting method (View B)

Selection Information

Basic Specifications¹

LM Guide	Basic dynamic load rating C (N)		14,200				
	Basic static load rating C ₀ (N)		24,200				
Ball screw	Ball screw lead (mm)		5	10	16	20	30
	Basic dynamic load rating C _a (N)		5,400	9,800	5,800	5,500	4,300
	Basic static load rating C _{0a} (N)		13,300	25,200	12,900	14,200	9,300
	Screw shaft diameter (mm)		Ø16	Ø15	Ø16	Ø15	
	Thread minor diameter (mm)		Ø13.5	Ø12.5	Ø13.7	Ø12.5	
	Ball center-to-center diameter (mm)		Ø16.75	Ø15.75	Ø16.65	Ø15.75	
	Permissible rotational speed ² (min ⁻¹)		5,900	4,440	4,200	4,440	
Bearing (fixed side)	Axial direction	Basic dynamic load rating C _a (N)	6,100				
		Static permissible load P _{0a} (N)	2,100				
Base	Geometric moment of inertia ³	I _x ⁴ (mm ⁴)	1.61×10 ⁵				
		I _y ⁵ (mm ⁴)	2.47×10 ⁵				
		Mass (kg/m)	4.9				
Starting torque ⁶ (N-cm)	Ball screw QZ	Without QZ	14	13.4	18.1	17.2	20.8
		With QZ	30.1	39.7	43.9	46.8	47.8
Positioning repeatability (mm)		±0.02					
Backlash (mm)		0.05					
Permissible input torque (N-m)	Direct coupling	1.9	2.8				
	Motor wrap	1.9	2.2				
Static permissible load ⁷ (N)	Reverse-radial direction	9,600					
	Horizontal direction	2,900					
	Axial direction	2,100					
Static permissible moment ⁸ (N-m)	LM Guide QZ	Without QZ	M _x : 430, M _y : 240, M _c : 670				
		With QZ	M _x : 570, M _y : 260, M _c : 670				
Standard grease/Grease nipple used	LM Guide	THK AFB-LF Grease/ PB1021B					
	Ball screw	THK AFB-LF Grease/ Without nipple					

Static Permissible Moment

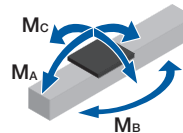

Static Permissible Load

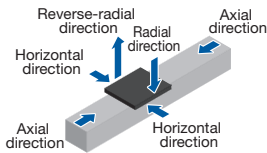

Geometric Moment of Inertia

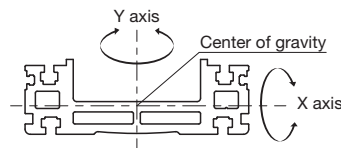

¹ These are the values for LM Guide model HV: SHS15V specifications.

² The permissible rotational speed may decrease as the stroke becomes longer.

³ These are the values for the cross-sectional characteristics of the aluminum base.

⁴ I_x is the geometric moment of inertia about the X axis.

⁵ I_y is the geometric moment of inertia about the Y axis.

⁶ The starting torque refers to the values when AFB-LF Grease is used.

⁷ The static permissible load is a value limited by the bolt tightening strength, the basic static load rating of the LM Guide and ball screw, and the static permissible load of the bearing.

⁸ Static permissible moment is the maximum moment that can be permitted while the product is stationary.

The reference for M_A and M_c moments is the top surface of the table, while the reference for M_B moments is the center of the table.

End plate/motor mounting plate ⑧	Cover/ bellows ⑨	Sensor ⑩	Cable carrier ⑪																																																
A	C	2	J																																																
<table border="1"> <tr> <td>With direct coupling</td> <td>N: Without cover</td> <td>N: None</td> <td>N: None</td> </tr> <tr> <td>A</td> <td>C: With cover</td> <td>2</td> <td>A</td> </tr> <tr> <td>B</td> <td>J: With bellows</td> <td>3</td> <td>B</td> </tr> <tr> <td>E</td> <td></td> <td>6</td> <td>C</td> </tr> <tr> <td>F</td> <td>With cover → p. 13</td> <td>G</td> <td>D</td> </tr> <tr> <td>H</td> <td>With bellows → p. 23</td> <td>Sensors → p. 14</td> <td>E</td> </tr> <tr> <td colspan="4">With motor wrap</td> </tr> <tr> <td>B14</td> <td></td> <td></td> <td>F</td> </tr> <tr> <td>F11</td> <td></td> <td></td> <td>G</td> </tr> <tr> <td></td> <td></td> <td></td> <td>H</td> </tr> <tr> <td></td> <td></td> <td></td> <td>I</td> </tr> <tr> <td></td> <td></td> <td></td> <td>J</td> </tr> </table>				With direct coupling	N: Without cover	N: None	N: None	A	C: With cover	2	A	B	J: With bellows	3	B	E		6	C	F	With cover → p. 13	G	D	H	With bellows → p. 23	Sensors → p. 14	E	With motor wrap				B14			F	F11			G				H				I				J
With direct coupling	N: Without cover	N: None	N: None																																																
A	C: With cover	2	A																																																
B	J: With bellows	3	B																																																
E		6	C																																																
F	With cover → p. 13	G	D																																																
H	With bellows → p. 23	Sensors → p. 14	E																																																
With motor wrap																																																			
B14			F																																																
F11			G																																																
			H																																																
			I																																																
			J																																																
100 W cannot be selected with motor wrap. End plate → p. 11 Cable carrier → p. 14																																																			

Motor Selection Information

■ LM Guide

LM Guide model	Moving part mass (kg)	Sliding resistance (N)
GL15N--SV (SSR15XV)	1.7	16.2
GL15N--SW (SSR15XW)	2.2	16.6
GL15N--SWQ (SSR15XWQZ)	2.4	26.6
GL15N--HV (SHS15V)	2.2	17.2
GL15N--HVQ (SHS15VQZ)	2.4	33.2

■ Ball Screw

Base length ¹ (mm)	Lead (mm)	Ball screw model	Shaft length ² (mm)
340 to 1,420	5	BTK1605V-2.6ZZ	311 to 1,391
	10	BLK1510-5.6ZZ	
	16	BLK1616-3.6ZZ	
	20	WTF1520-3ZZ	
	30	WTF1530-2ZZ	

■ Motor Mounting Part

Direct coupling Shaft end diameter (mm)	Motor wrap Timing pulley Inertial moment x 10 ⁻⁴ (kg·m ²)	
	Ø8h7	0.12

¹ For base length, see the dimensional table. → p. 9 to 10
² This length is that of a ball screw shaft directly coupled to the motor.
 For motor wrap specifications, the ball screw shaft is 74 mm longer.
 Note: Please see p. 11 for information on applicable couplings.

Permissible Overhang Length³

Horizontal

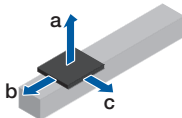

Wall-Mounted

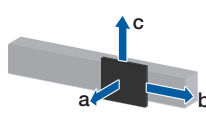

Vertical

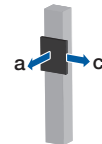

100 W	Ball screw lead (mm)	Load mass (kg)	a (mm)	b (mm)	c (mm)
Direct coupling/ Motor wrap	5	15	1,200	1,200	1,200
		30	1,200	930	1,200
		60	1,200	450	720

100 W	Ball screw lead (mm)	Load mass (kg)	a (mm)	b (mm)	c (mm)
Direct coupling/ Motor wrap	5	15	1,200	1,200	1,200
		30	1,200	900	1,200
		60	690	430	1,200

100 W	Ball screw lead (mm)	Load mass (kg)	a (mm)	c (mm)
Direct coupling/ Motor wrap	5	3	1,200	1,200
		6.5	1,200	1,200
		13	1,200	1,200

200 W	Ball screw lead (mm)	Load mass (kg)	a (mm)	b (mm)	c (mm)
Direct coupling/ Motor wrap	10	15	1,200	1,200	1,200
		30	1,200	730	1,130
		60	1,200	350	540
		12.5	1,200	1,200	1,200
		25	1,200	880	1,200
		50	1,200	420	620
	20	11	1,200	1,200	1,200
		22.5	1,200	780	1,080
		45	1,200	370	520

200 W	Ball screw lead (mm)	Load mass (kg)	a (mm)	b (mm)	c (mm)
Direct coupling/ Motor wrap	10	15	1,200	1,200	1,200
		30	1,120	710	1,200
		60	520	330	1,200
		12.5	1,200	1,200	1,200
		25	1,200	860	1,200
		50	610	400	1,200
	20	11	1,200	1,200	1,200
		22.5	1,110	760	1,200
		45	520	350	1,200

200 W	Ball screw lead (mm)	Load mass (kg)	a (mm)	c (mm)
Direct coupling/ Motor wrap	10	4	1,200	1,200
		8	1,200	1,200
		16	1,200	1,200
		1.5	1,200	1,200
		3.5	1,200	1,200
		7	1,200	1,200
	20	2.5	1,200	1,200
		5	1,200	1,200
		10	1,200	1,200

400 W	Ball screw lead (mm)	Load mass (kg)	a (mm)	b (mm)	c (mm)
Direct coupling/ Motor wrap	20	15	1,200	1,180	1,200
		30	1,200	580	800
		60	1,200	270	380
	30	7.5	1,200	1,200	1,200
		15	1,200	1,180	1,200
		30	1,200	570	720

400 W	Ball screw lead (mm)	Load mass (kg)	a (mm)	b (mm)	c (mm)
Direct coupling/ Motor wrap	20	15	1,200	1,160	1,200
		30	810	550	1,200
		60	370	250	1,200
	30	7.5	1,200	1,200	1,200
		15	1,200	1,160	1,200
		30	750	550	1,200

400 W	Ball screw lead (mm)	Load mass (kg)	a (mm)	c (mm)
Direct coupling/ Motor wrap	20	4	1,200	1,200
		8	1,200	1,200
		16	1,050	1,050
	30	2.5	1,200	1,200
		5	1,200	1,200
		10	1,200	1,200

³ This is the value with the travel life of the LM Guide limited to 10,000 km (5,000 km for leads of 5 mm only). The calculation conditions are as follows.
 Stroke: 640 mm (LM Guide: SHS15V) / Acceleration/deceleration: 0.3 G / Speed: Rated speed / Overhang direction: Loaded only in a single direction. Dimensions a, b, and c are from the center of the table's upper surface.

Dimensions

Motor Wrap

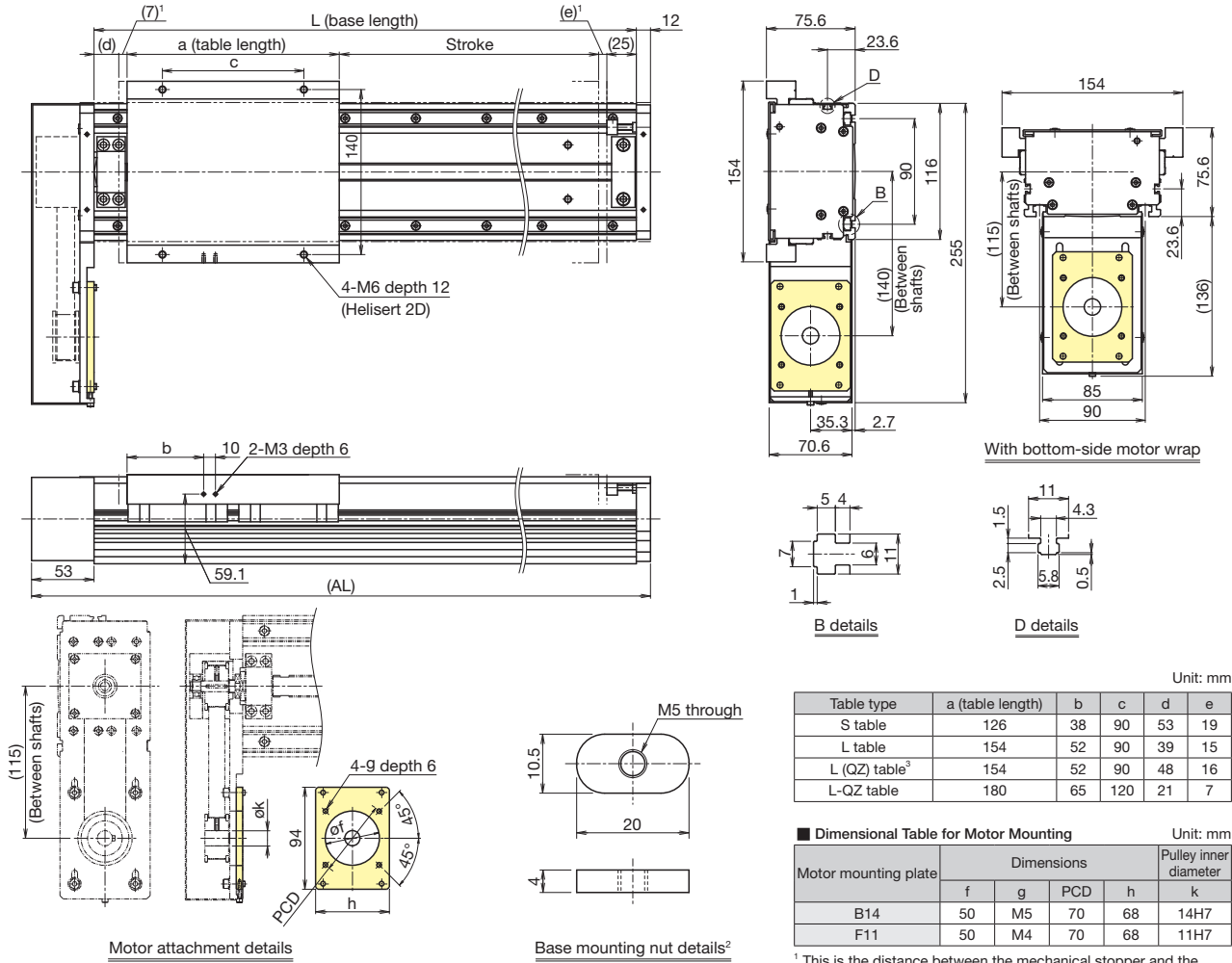

Unit: mm

Table type	a (table length)	b	c	d	e
S table	126	38	90	53	19
L table	154	52	90	39	15
L (QZ) table ³	154	52	90	48	16
L-QZ table	180	65	120	21	7

■ Dimensional Table for Motor Mounting Unit: mm

Motor mounting plate	Dimensions					Pulley inner diameter
	f	g	PCD	h	k	
B14	50	M5	70	68	14H7	
F11	50	M4	70	68	11H7	

¹ This is the distance between the mechanical stopper and the stroke starting position.
² Nuts for mounting the base are included. The quantity is listed in the dimensional table.
³ Indicates QZ specifications for the ball screw only.

Stroke (mm) (Stroke between mechanical stoppers)	S table	110 (136)	230 (256)	350 (376)	470 (496)	590 (616)	830 (856)	1,010 (1,036)	1,190 (1,216)
	L table	100 (122)	220 (242)	340 (362)	460 (482)	580 (602)	820 (842)	1,000 (1,022)	1,180 (1,202)
	L (QZ) table ³	90 (113)	210 (233)	330 (353)	450 (473)	570 (593)	810 (833)	990 (1,013)	1,170 (1,193)
	L-QZ table	100 (114)	220 (234)	340 (354)	460 (474)	580 (594)	820 (834)	1,000 (1,014)	1,180 (1,194)
Maximum speed ⁴ (mm/s)	Ball screw lead: 5 mm	490				370	200	140	100
	Ball screw lead: 10 mm	740				700	380	260	190
	Ball screw lead: 16 mm	1,120					660	460	340
	Ball screw lead: 20 mm	1,480				1,390	750	520	380
	Ball screw lead: 30 mm	2,220				2,120	1,140	790	580
Dimensions (mm)	L (base length)	340	460	580	700	820	1,060	1,240	1,420
	AL	405	525	645	765	885	1,125	1,305	1,485
Nuts for mounting the base		4	4	6	6	8	10	10	12
Mass ⁵ (kg)	L-QZ table (SHS15V)	8.2	9.3	10.5	11.6	12.8	15.1	16.8	18.5

³ Indicates QZ specifications for the ball screw only.
⁴ The maximum speed is restricted by the permissible speed of the actuator.
⁵ The mass is that of products with a cover and QZ.

Options

End Plate (Direct Coupling)

Several types of end plate for mounting motors are available.
Specify an end plate that matches the motor used.

Motor type	Manufacturer	Series	Motor model	Motor rated output (W)	Flange size	End plate	Compatible coupling model		
							MIKI PULLEY CO., LTD.	Nabeya Bi-tech Kaisha (NBK)	
AC servo motor	YASKAWA Electric Corporation	Σ-V	SGMJV-01	100	40×40	A	SFC-020DA2-8B-8B	XGL2-19C-8-8	
			SGMAV-01						
			SGMJV-02	200	60×60	B	SFC-030DA2-8B-14B	XGT2-27C-8-14	
			SGMAV-02						
		Σ-7	SGM7J-01	100	40×40	A	SFC-020DA2-8B-8B	XGL2-19C-8-8	
			SGM7A-01						
			SGM7J-02	200	60×60	B	SFC-030DA2-8B-14B	XGT2-27C-8-14	
			SGM7A-02						
		Σ-X	SGMXJ-01	100	40×40	A	SFC-020DA2-8B-8B	XGL2-19C-8-8	
			SGMXA-01						
			SGMXJ-02	200	60×60	B	SFC-030DA2-8B-14B	XGT2-27C-8-14	
			SGMXA-02						
	SGMXJ-04	400	60×60	B	SFC-030DA2-8B-14B	XGT2-27C-8-14			
	SGMXA-04								
	Mitsubishi Electric Corporation	MELSERVO	J4	HG-KR13	100	40×40	A	SFC-020DA2-8B-8B	XGL2-19C-8-8
				HG-MR13					
				HG-KR23	200	60×60	B	SFC-030DA2-8B-14B	XGT2-27C-8-14
				HG-MR23					
				HG-KR43	400	60×60	B	SFC-030DA2-8B-14B	XGT2-27C-8-14
				HG-MR43					
			J5	HK-KT13W	100	40×40	A	SFC-020DA2-8B-8B	XGL2-19C-8-8
				HK-KT23W	200	60×60	B	SFC-030DA2-8B-14B	XGT2-27C-8-14
				HK-KT43W	400				
			JN	HF-KN13	100	40×40	A	SFC-020DA2-8B-8B	XGL2-19C-8-8
				HF-KN23	200	60×60	B	SFC-030DA2-8B-14B	XGT2-27C-8-14
				HF-KN43	400				
	TAMAGAWA SEIKI CO., LTD.	TBL-II	TS4603	100	40×40	A	SFC-020DA2-8B-8B	XGL2-19C-8-8	
			TS4607	200	60×60	B	SFC-030DA2-8B-14B	XGT2-27C-8-14	
			TS4609	400					
		TBL-IV	TSM3104	100	40×40	A	SFC-020DA2-8B-8B	XGL2-19C-8-8	
			TSM3202	200	60×60	B	SFC-030DA2-8B-14B	XGT2-27C-8-14	
	Panasonic Corporation	MINAS	A5	MSMD01	100	38×38	E	SFC-020DA2-8B-8B	XGL2-19C-8-8
				MSME01					
				MSMD02	200	60×60	F	SFC-030DA2-8B-11B	XGT2-25C-8-11
				MSME02					
A6			MSMF01	100	38×38	E	SFC-020DA2-8B-8B	XGL2-19C-8-8	
			MHMF01		40×40	A	SFC-020DA2-8B-8B	XGL2-19C-8-8	
			MSMF02	200	60×60	F	SFC-030DA2-8B-11B	XGT2-25C-8-11	
			MHMF02						
KEYENCE CORPORATION	SV	SV-M010	100	40×40	A	SFC-020DA2-8B-8B	XGL2-19C-8-8		
		SV-M020	200	60×60	B	SFC-030DA2-8B-14B	XGT2-27C-8-14		
	SV2	SV2-M010	100	40×40	A	SFC-020DA2-8B-8B	XGL2-19C-8-8		
		SV2-M020	200	60×60	B	SFC-030DA2-8B-14B	XGT2-27C-8-14		
SANYO DENKI CO., LTD.	SANMOTION R	R2□A04010	100	40×40	A	SFC-020DA2-8B-8B	XGL2-19C-8-8		
		R2□A06020	200	60×60	B	SFC-030DA2-8B-14B	XGT2-27C-8-14		
OMRON Corporation	OMNUC G5	R88M-K10030	100	40×40	A	SFC-020DA2-8B-8B	XGL2-19C-8-8		
		R88M-K20030	200	60×60	F	SFC-030DA2-8B-11B	XGT2-25C-8-11		
		R88M-1M10030	100	40×40	A	SFC-020DA2-8B-8B	XGL2-19C-8-8		
		R88M-1M20030	200	60×60	F	SFC-030DA2-8B-11B	XGT2-25C-8-11		

Motor type	Manufacturer	Series	Motor model	Flange size	End plate	Compatible coupling model		
						MIKI PULLEY CO., LTD.	Nabeya Bi-tech Kaisha (NBK)	
Stepper motor	ORIENTAL MOTOR CO., LTD.	5-phase	αStep	AZ6*, AR6*	60×60	H	SFC-025DA2-8B-10B-L43	XGT2-25C-8-10
			CRK*	CRK56* (CRK569PM*)			SFC-025DA2-8B-8B-L43	XGT2-25C-8-8
			RK II	RKS56*			(SFC-025DA2-8B-10B-L43)	(XGT2-25C-8-10)
			PKP*	PKP56* (PKP569FM*)			SFC-025DA2-8B-10B-L43	XGT2-25C-8-10
							SFC-025DA2-8B-8B-L43	XGT2-25C-8-8
	KEYENCE CORPORATION	2-phase	QS-M60				(SFC-025DA2-8B-10B-L43)	(XGT2-25C-8-10)
	SANYO DENKI CO., LTD.	5-phase	PB	PBDM60*, PBA**60*			SFC-025DA2-8B-10B-L43	XGT2-25C-8-10
				FAM56*/FDM56*/FA512M60/FB512M60			SFC-025DA2-8B-10B-L43	XGT2-25C-8-10
							SFC-025DA2-8B-10B-L43	XGT2-25C-8-10
							SFC-025DA2-8B-10B-L43	XGT2-25C-8-10
						SFC-025DA2-8B-8B-L43	XGT2-25C-8-8	
	2-phase	DB16H78*				SFC-025DA2-8B-8B-L43	XGT2-25C-8-8	

* When specifying a coupling, note that the motor axis diameter is different for models in parentheses.

Notes: 1. The table shows only a portion of the model numbers for motors. For details regarding model numbers, please see the catalog for each respective motor manufacturer.
2. If the maximum torque of the installed motor will exceed the permissible input torque (p. 7), please consider a safety measure to limit the torque.

Motor Mounting Plate (Motor Wrap)

Motor mounting plates are available for attaching a variety of motors.
Specify a motor mounting plate that matches the motor used.

Motor type	Manufacturer	Series	Motor model	Motor rated output (W)	Flange size	Motor mounting plate	
AC servo motor	YASKAWA Electric Corporation	Σ-V	SGMJV-02	200	60×60	B14	
			SGMAV-02				
		Σ-7	SGM7J-02	200	60×60	B14	
			SGM7A-02				
		Σ-X	SGMXJ-02	200	60×60	B14	
			SGMXA-02				
	Mitsubishi Electric Corporation	MELSERVO	J4	HG-KR23	200	60×60	B14
				HG-MR23			
			J5	HK-KT23W	200	60×60	B14
		JN	HF-KN23	200	60×60	B14	
	TAMAGAWA SEIKI CO., LTD.	TBL-II	TS4607	200	60×60	B14	
			TS4609	400			
		TBL-IV	TSM3202	200	60×60	B14	
	Panasonic Corporation	MINAS	A5	MSMD02	200	60×60	F11
				MSME02			
			A6	MSMF02	200	60×60	F11
				MHMF02			
KEYENCE CORPORATION	SV	SV-M020	200	60×60	B14		
	SV2	SV2-M020	200	60×60	B14		
SANYO DENKI CO., LTD.	SANMOTION R	R2□A06020	200	60×60	B14		
OMRON Corporation	OMNUC G5	R88M-K20030	200	60×60	F11		
	1S	R88M-1M20030	200	60×60	F11		

Notes: 1. The table shows only a portion of the model numbers for motors. For details regarding model numbers, please see the catalog for each respective motor manufacturer. Please select a motor shaft with a keyed end.

2. If the maximum torque of the installed motor will exceed the permissible input torque (p. 7), please consider a safety measure to limit the torque.

Options

QZ Lubricator

LM Guide

The QZ Lubricator feeds the right amount of lubricant to the LM rail raceway. This allows an oil film to continuously form between the balls and the raceway, and it significantly extends the lubrication maintenance intervals.

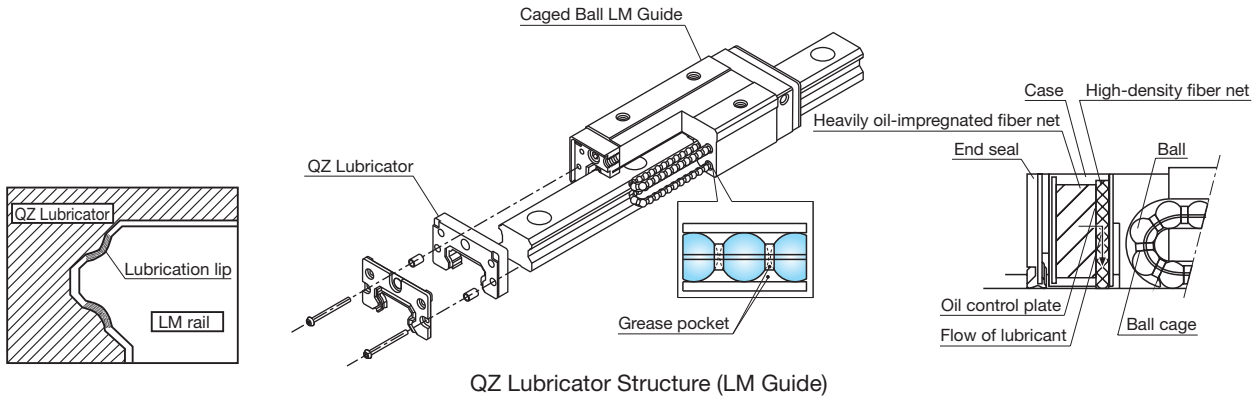

Ball Screw

The QZ Lubricator feeds the right amount of lubricant to the ball screw shaft raceway. This allows an oil film to continuously form between the balls and the raceway, and it significantly extends the lubrication maintenance intervals.

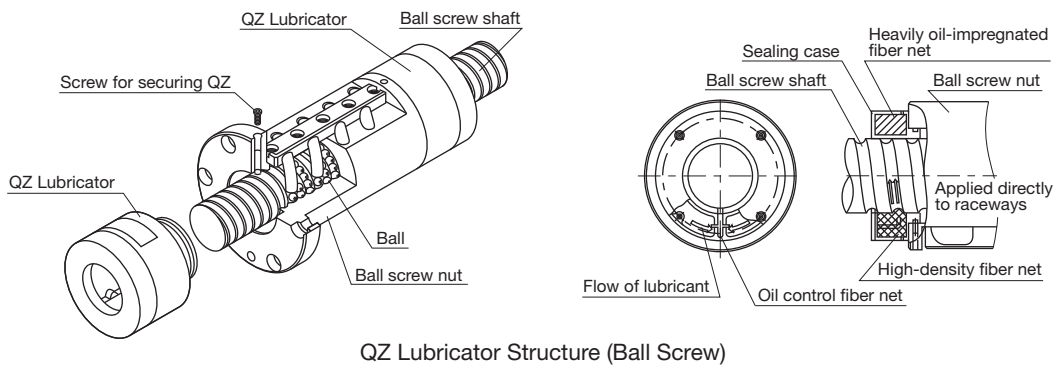

Cover

A simple cover is provided to protect the interior.

The cover is shared between the GL15N and GL20N.

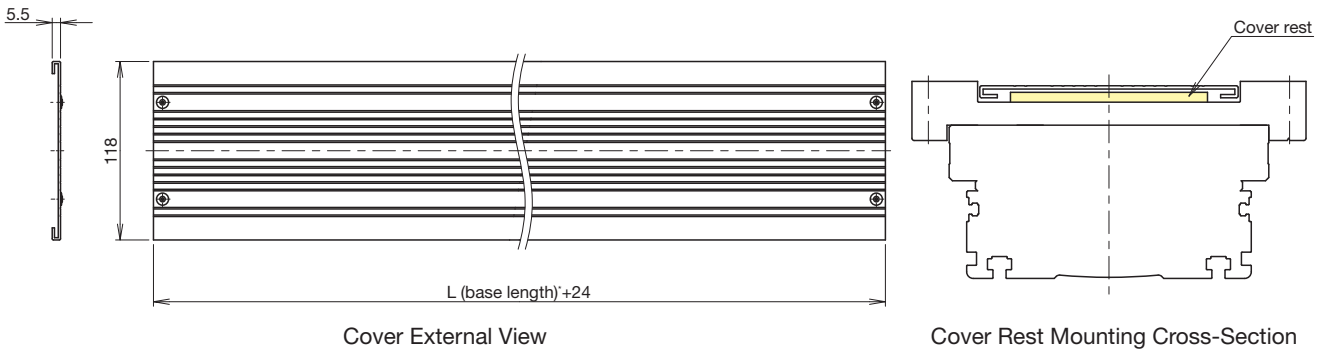

* For base length, see the dimensional table. → p. 9 to 10

Notes: 1. If the base is long, the cover will experience more deflection.

Therefore, to prevent interference with the table, a cover rest is installed on the table as standard for models with base lengths of 1,000 mm or more. (See the figure above.)

However, please note that when the base is long, the deflection of the cover will increase due to its weight, which may cause the cover to come in contact with other components (such as the rail or belt).

2. Take care when using this product in anything other than a horizontal orientation. The deflection of the cover may cause it to come in contact with parts mounted on the table.

Sensors

Optional photo sensors and proximity sensors are available.

Sensors can be mounted using the T-slot on the side of the base.

Symbol	Description	Model	Accessories
N	None	-	-
2	Photo sensors ¹ (x3)	EE-SX671 (OMRON Corporation)	Mounting screws/nuts, sensor dog (x1 or x2), mounting plates (x3)
6	Photo sensors ¹ (x3)	EE-SX674 (OMRON Corporation)	Mounting screws/nuts, sensor dog (x1 or x2), mounting plates (x3)
3	Proximity sensors: N.O. contact ² (x3)	TL-W3MC1 (OMRON Corporation)	Mounting screws/nuts, sensor dog (x1 or x2)
G	Proximity sensors: N.O. contact ² (x1) N.C. contact ³ (x2)	TL-W3MC1 (OMRON Corporation) TL-W3MC2 (OMRON Corporation)	Mounting screws/nuts, sensor dog (x1 or x2)

¹ The photo sensors can be switched between ON when lit and ON when unlit.

Notes: 1. All sensor output is NPN.

² N.O. contact: Normally open contact

2. Sensors and accessories will be mounted to the unit before shipping.

³ N.C. contact: Normally closed contact

Photo Sensor Mounting Dimensions

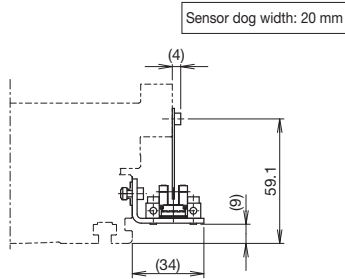

Symbol	Model	Manufacturer
2	EE-SX671	OMRON Corporation

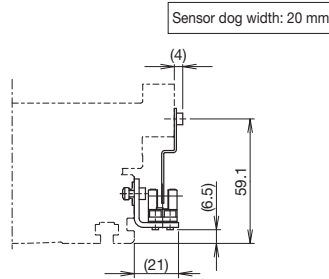

Symbol	Model	Manufacturer
6	EE-SX674	OMRON Corporation

Proximity Sensor Mounting Dimensions

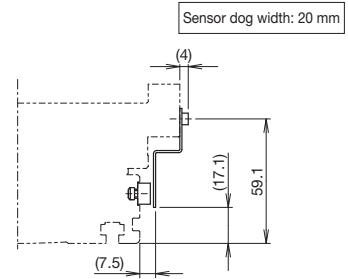

Symbol	Model	Manufacturer
3	TL-W3MC1	OMRON Corporation
G	TL-W3MC1	
	TL-W3MC2	

Cable Carrier

A variety of cable carriers can be mounted using the T-slot on the side of the base.

When selecting a cable carrier, specify the corresponding symbol from the table below.

Symbol	Cable carrier model	Manufacturer
A	TKP0180W40R28	TSUBAKIMOTO CHAIN CO.
B	TKP0180W40R37	
C	TKP0180W40R50	
D	TKP35H22-30W25R37	
E	TKP35H22-30W25R50	

Symbol	Cable carrier model	Manufacturer
F	TKP35H22-30W25R75	TSUBAKIMOTO CHAIN CO.
G	TKP35H22-30W50R37	
H	TKP35H22-30W50R50	
I	TKP35H22-30W50R75	
J	KSH-24L-42	THK CO., LTD.

Note 3: For the selection of the cable carrier, please see the corresponding cable carrier catalog.

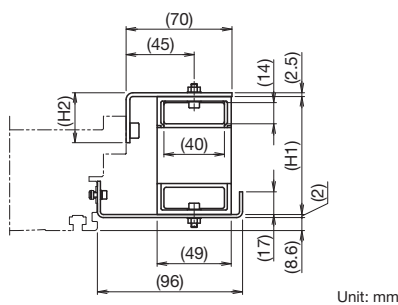

Symbol	Cable carrier model	H1	H2
A	TKP0180W40R28	78	33
B	TKP0180W40R37	96	51
C	TKP0180W40R50	122	77

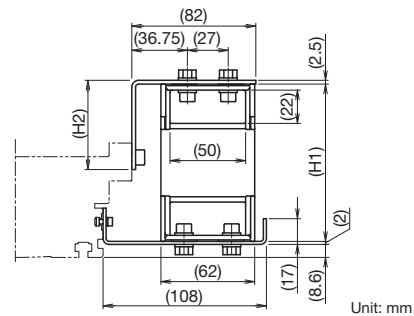

Symbol	Cable carrier model	H1	H2
G	TKP35H22-30W50R37	104	59
H	TKP35H22-30W50R50	130	85
I	TKP35H22-30W50R75	180	135

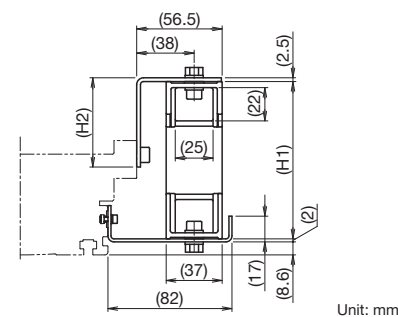

Symbol	Cable carrier model	H1	H2
D	TKP35H22-30W25R37	104	59
E	TKP35H22-30W25R50	130	85
F	TKP35H22-30W25R75	180	135

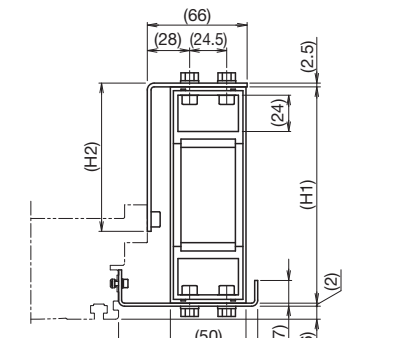

Symbol	Cable carrier model	H1	H2
J	KSH-24L-42	143	98

GL15N

Direct motor coupling	Width 154 mm	Height 75.6 mm	Max. stroke 1,695 mm	Max. speed 1,830 mm/s	Belt-driven type
-----------------------	--------------	----------------	----------------------	-----------------------	------------------

Model Number Coding

Model ①	Stroke ②	LM Guide model ③	LM Guide with/without QZ ④	Drive system ⑤	With/without motor ⑥	Motor bracket ⑦
GL15N	1280	SW	Q	EH	0	B1
GL15N	0260: 260 mm to 1695: 1,695 mm	SV: SSR15XV SW: SSR15XW HV: SHS15V	No symbol: Without QZ Q: With QZ	EH: Belt	0: Without motor (Without coupling. If necessary, please specify.) 1: With motor (THK will purchase and mount the motor you specify.)	N: None B1 B2

When "J" (with bellows) is selected for ⑩ Cover/bellows, specify the stroke with bellows. → p. 24

Please select one of the combinations below.

Table type	③ LM Guide model	④ LM Guide with/without QZ
S table	SV	No symbol: Without QZ
L table	SW / HV	No symbol: Without QZ
L-QZ table	SW / HV	Q: With QZ

Table Type

The block table type is determined by the LM Guide you select. In addition, the stroke range varies depending on the block table type.

- S table Short table (LM Guide model: SSR15XV)
This type has a shorter table to allow for a longer stroke range.
- L table Long table (LM Guide models: SSR15XW, SHS15V)
This type is optimal for high loads or when loads are positioned away from the center of the table.
- L-QZ table Long table with QZ Lubricator (LM Guide models: SSR15XWQZ, SHS15VQZ)
A QZ Lubricator is attached to the LM Guide. (This table is longer than an L table. See the dimensional tables on p. 17 to 18.)

Selection Information

Basic Specifications¹

LM Guide	Basic dynamic load rating C (N)	14,200	
	Basic static load rating C ₀ (N)	24,200	
Base	Geometric moment of inertia ²	I_x^3 (mm ⁴)	1.61×10^5
		I_y^4 (mm ⁴)	2.47×10^6
		Mass (kg/m)	4.9
Permissible input rotational speed (min ⁻¹)		3,000	
Starting torque (N-cm)	LM Guide	Without QZ	43.7
		With QZ	77.3
Positioning repeatability (mm)		±0.08	
Permissible input torque (N-m) ⁵		4.8	
Static permissible load ⁶ (N)		Reverse-radial direction	9,600
		Horizontal direction	2,900
		Axial direction	270
Static permissible moment ⁷ (N-m)	LM Guide QZ	Without QZ	M _x : 430, M _y : 240, M _c : 670
		With QZ	M _x : 570, M _y : 260, M _c : 670
Standard grease/Grease nipple used		THK AFB-LF Grease/ PB1021B	

¹ These are the values for LM Guide model HV: SHS15V specifications.
² These are the values for the cross-sectional characteristics of the aluminum base.
³ I_x is the geometric moment of inertia about the X axis.
⁴ I_y is the geometric moment of inertia about the Y axis.
⁵ This is the input torque for the shaft end.
⁶ The static permissible load is a value limited by the bolt tightening strength, LM Guide unit, belt, and pulley shaft.
⁷ Static permissible moment is the maximum moment that can be permitted while the product is stationary.
 The reference for M_x and M_c moments is the top surface of the table, while the reference for M_y moments is the center of the table.

Static Permissible Moment

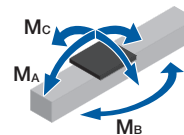

Static Permissible Load

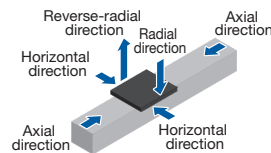

Geometric Moment of Inertia

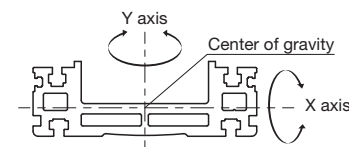

Belt specification reduction gear ⑧	Belt specification reduction ratio ⑨	Cover/bellows ⑩	Sensor ⑪	Cable carrier ⑫
G3	03	C	2	J
No symbol: No reduction gear	No symbol: No reduction gear	N: Without cover C: With cover J: With bellows	N: None 2 3 6 G	N: None A B C D E F G H I J
G1	03: 1/3	With cover → p. 21	Sensors → p. 22	
G2	05: 1/5	With bellows → p. 24		
G3	09: 1/9			
G4				
G5				

Motor Selection Information

■ LM Guide

LM Guide model	Moving part mass (kg)	Sliding resistance (N)
GL15N--SV (SSR15XV)	1.2	16.2
GL15N--SW (SSR15XW)	1.7	16.6
GL15N--SWQ (SSR15XWQZ)	1.8	26.6
GL15N--HV (SHS15V)	1.7	17.2
GL15N--HVQ (SHS15VQZ)	1.8	33.2

■ Belt Drive

Belt model	Mass ¹ (kg)
025-MA5	0.38

■ Timing Pulley

Timing pulley model	Diameter (PCD) (mm)	Table travel amount per pulley rotation (mm)	Inertial moment (2 total) x 10 ⁻⁴ (kg·m ²)
022-MA5-025	Ø35.01	110	0.289

■ Reduction Gear

Reduction ratio	Motor rated output (W)	Inertial moment x 10 ⁻⁴ (kg·m ²)
1/3	100	0.089
1/3	200	0.175
1/3	400	0.175
1/5	100	0.06
1/5	200	0.147
1/9	100	0.05
1/9	200	0.273

¹ The belt mass is the mass when the base has the maximum length.

Permissible Overhang Length²

Horizontal

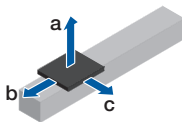

200 W		Load mass (kg)	a (mm)	b (mm)	c (mm)
Reduction ratio	1/3	3	1,200	1,200	1,200
		6	1,200	1,200	1,200
		12	1,200	1,200	1,200
	1/5	7.5	1,200	1,200	1,200
		15	1,200	1,180	1,200
		30	1,200	580	840

400 W		Load mass (kg)	a (mm)	b (mm)	c (mm)
Reduction ratio	1/3	6	1,200	1,200	1,200
		12.5	1,200	1,200	1,200
		25	1,200	700	1,010

² This is the value with the travel life of the LM Guide limited to 10,000 km.

The calculation conditions are as follows.

Stroke: 975 mm (LM Guide: SHS15V) / Acceleration/deceleration: 0.3 G / Speed: Rated speed / Overhang direction: Loaded only in a single direction.

Dimensions a, b, and c are from the center of the table's upper surface.

Table Travel Amount Per Motor Rotation

Pulley pitch circle diameter (mm)	Table travel amount per motor rotation (mm)			
	No reduction gear ³	Reduction ratio		
		1/3	1/5	1/9
Ø35.01	110	36.7	22	12.2

³ The timing pulley's pitch circle diameter is large, so we recommend using a reduction gear.

Dimensions

With Cover

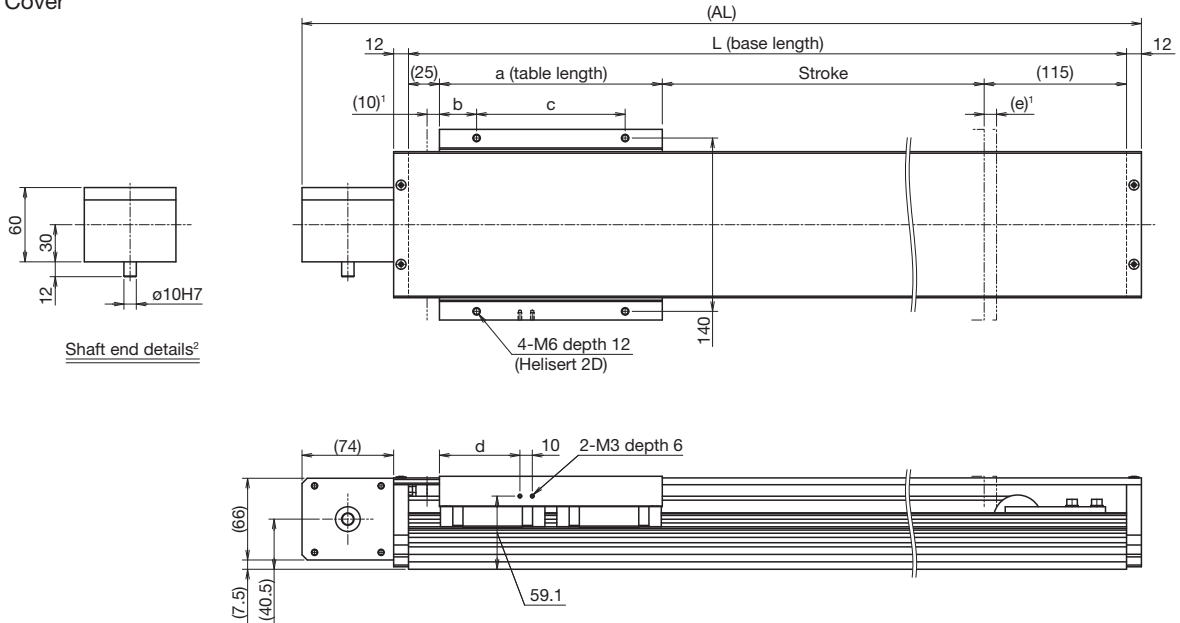

Without Cover

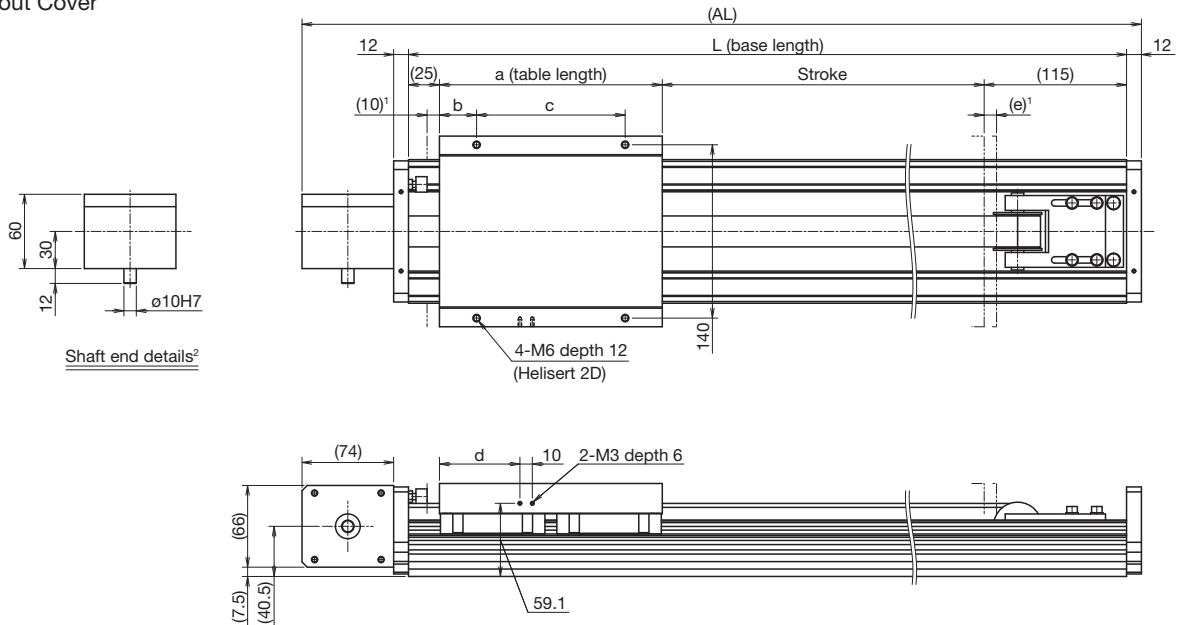

¹ This is the distance between the mechanical stopper and the stroke starting position.

² See p. 18 for details about the bracket mounting surface.

Unit: mm

Table type	a (table length)	b	c	d	e
S table	126	18	90	38	9
L table	154	32	90	52	11
L-QZ table	180	30	120	65	10

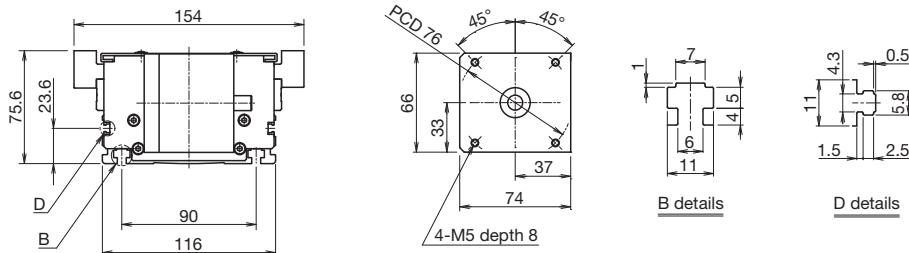

Side surface details

Bracket mounting surface details

B details

D details

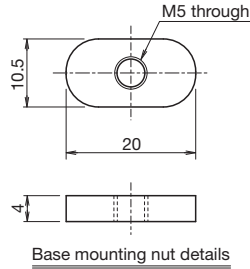

Base mounting nut details

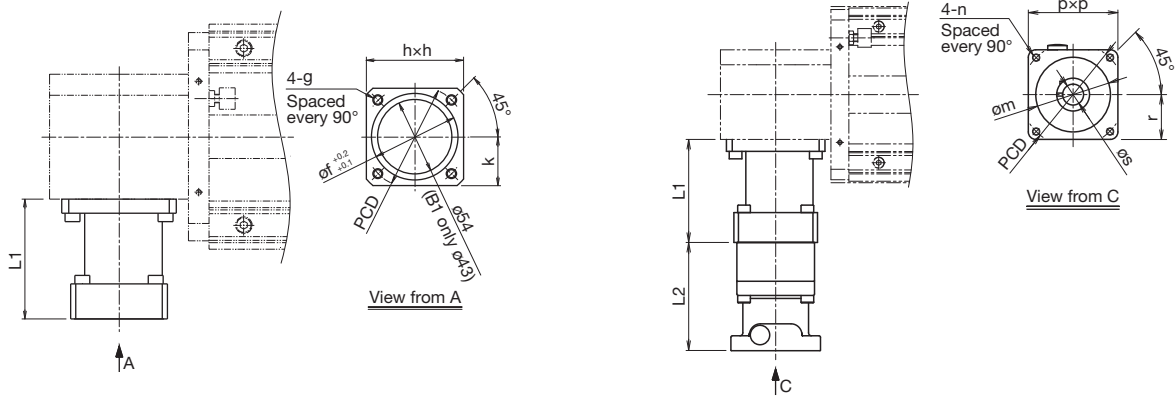

View from A

View from C

Unit: mm

Bracket symbol	Dimensions					
	f	g	PCD	h	k	L1
B1	50	5.5 drill through	60	56	28	69
B2	70	6.6 drill through	90	78	39	86

Unit: mm

Bracket symbol	Dimensions							
	m	n	PCD	p	r	s	L1	L2
B1G1**	30	M4 depth 6	46	40	20	8	69	67.5
B1G2**	30	M3 depth 6	45	40	20	8	69	67.5
B1G3**	50	M5 depth 10	70	60	30	14	69	72.5
B1G4**	50	M4 depth 10	70	60	30	11	69	72.5
B1G5**	50	M5 depth 10	70	60	30	14	69	72.5
B2G3**	50	M5 depth 8	70	60	30	14	86	89.5
B2G4**	50	M4 depth 8	70	60	30	11	86	89.5
B2G5**	50	M4 depth 8	70	60	30	14	86	89.5

Note: ** indicates the reduction ratio symbol.

Stroke (mm) (Stroke between mechanical stoppers)	S table	315 (334)	435 (454)	555 (574)	795 (814)	975 (994)	1,155 (1,174)	1,335 (1,354)	1,515 (1,534)	1,695 (1,714)
	L table	285 (306)	405 (426)	525 (546)	765 (786)	945 (966)	1,125 (1,146)	1,305 (1,326)	1,485 (1,506)	1,665 (1,686)
	L-QZ table	260 (280)	380 (400)	500 (520)	740 (760)	920 (940)	1,100 (1,120)	1,280 (1,300)	1,460 (1,480)	1,640 (1,660)
Maximum speed ³ (mm/s)	Reduction ratio: 1/3	1,830								
	Reduction ratio: 1/5	1,100								
Dimensions (mm)	L (Base length)	580	700	820	1,060	1,240	1,420	1,600	1,780	1,960
	AL	678	798	918	1,158	1,338	1,518	1,698	1,878	2,058
Nuts for mounting the base		6	6	8	10	10	12	14	14	16
Mass ⁴ (kg)	L-QZ table (SHS15V)	9.9	11	12	14	15.5	17	18.6	20.1	21.6

³ The maximum speed is restricted by the permissible speed of the actuator.

⁴ The mass is that of products with a cover and QZ.

Options

Reduction Gear (Belt Specifications)

These are the reduction gears and motors that can be attached when B1 and B2 are selected for the motor bracket. Specify the motor bracket that matches the motor and reduction gear that will be used.

Reduction Ratio: 1/3

Motor type	Manufacturer	Series	Motor model	Motor rated output (W)	Reduction gear model	Symbol	Compatible reduction gear coupling		
AC servo motor	YASKAWA Electric Corporation	Σ-V	SGMAV-01	100	VRXF-3B-S-100	B1G103	MJC-33-10X12 (MIGHTY CORPORATION, LTD.)		
			SGMAV-02	200	VRXF-3B-S-200	B1G303			
			SGMAV-04	400	VRXF-3B-S-400	B1G303			
		Σ-7	SGM7A-01	100	VRXF-3B-S-100	B1G103			
			SGM7A-02	200	VRXF-3B-S-200	B1G303			
			SGM7A-04	400	VRXF-3B-S-400	B1G303			
		Σ-X	SGMXA-01	100	VRXF-3B-S-100	B1G103			
			SGMXA-02	200	VRXF-3B-S-200	B1G303			
			SGMXA-04	400	VRXF-3B-S-400	B1G303			
		Mitsubishi Electric Corporation	MELSERVO	J4	HG-KR13	100		VRXF-3B-S-100	B1G103
					HG-MR13			VRXF-3B-S-100	B1G103
					HG-KR23	200		VRXF-3B-S-200	B1G303
	HG-MR23			VRXF-3B-S-200	B1G303				
	HG-KR43			400	VRXF-3B-S-400	B1G303			
	HG-MR43				VRXF-3B-S-400	B1G303			
	J5		HK-KT13W	100	VRXF-3B-S-100	B1G103			
			HK-KT23W	200	VRXF-3B-S-200	B1G303			
			HK-KT43W	400	VRXF-3B-S-400	B1G303			
	JN		HF-KN13	100	VRXF-3B-S-100	B1G103			
			HF-KN23	200	VRXF-3B-S-200	B1G303			
			HF-KN43	400	VRXF-3B-S-400	B1G303			
	TAMAGAWA SEIKI CO., LTD.	TBL-II	TS4603	100	VRXF-3B-S-100	B1G103			
			TS4607	200	VRXF-3B-S-200	B1G303			
			TS4609	400	VRXF-3B-S-400	B1G303			
		TBL-IV	TSM3104	100	VRXF-3B-S-100	B1G103			
			TSM3202	200	VRXF-3B-S-200	B1G303			
			TSM3204	400	VRXF-3B-S-400	B1G303			
	Panasonic Corporation	MINAS	A5	MSMD01	100	VRXF-3B-S-100		B1G203	
				MSMD02	200	VRXF-3B-S-200		B1G403	
				MSMD04	400	VRXF-3B-S-400		B1G503	
		A6	MSMF01	100	VRXF-3B-S-100	B1G203			
			MSMF02	200	VRXF-3B-S-200	B1G403			
			MSMF04	400	VRXF-3B-S-400	B1G503			
	OMRON Corporation	OMNUC G5	R88M-K10030	100	VRXF-3B-S-100	B1G103			
			R88M-K20030	200	VRXF-3B-S-200	B1G403			
			R88M-K40030	400	VRXF-3B-S-400	B1G503			
		1S	R88M-1M10030	100	VRXF-3B-S-100	B1G103			
			R88M-1M20030	200	VRXF-3B-S-200	B1G403			
			R88M-1M40030	400	VRXF-3B-S-400	B1G503			

Reduction Ratio: 1/5

Motor type	Manufacturer	Series	Motor model	Motor rated output (W)	Reduction gear model	Symbol	Compatible reduction gear coupling		
AC servo motor	YASKAWA Electric Corporation	Σ-V	SGMAV-01	100	VRXF-5B-S-100	B1G105	MJC-33-10X12 (MIGHTY CORPORATION, LTD.)		
			SGMAV-02	200	VRXF-5B-S-200	B1G305			
			SGM7A-01	100	VRXF-5B-S-100	B1G105			
		Σ-7	SGM7A-02	200	VRXF-5B-S-200	B1G305			
			Σ-X	SGMXA-01	100	VRXF-5B-S-100		B1G105	
				SGMXA-02	200	VRXF-5B-S-200		B1G305	
		Mitsubishi Electric Corporation		MELSERVO	J4	HG-KR13		100	VRXF-5B-S-100
			HG-MR13			VRXF-5B-S-100			B1G105
			HG-KR23			200		VRXF-5B-S-200	B1G305
			HG-MR23		VRXF-5B-S-200			B1G305	
			J5		HK-KT13W	100		VRXF-5B-S-100	B1G105
					HK-KT23W	200		VRXF-5B-S-200	B1G305
	JN			HF-KN13	100	VRXF-5B-S-100		B1G105	
			HF-KN23	200	VRXF-5B-S-200	B1G305			
			TAMAGAWA SEIKI CO., LTD.	TBL-II	TS4603	100		VRXF-5B-S-100	B1G105
	TS4607				200	VRXF-5B-S-200		B1G305	
	TS4609				400	VRXF-5B-S-400		B1G305	
	TBL-IV			TSM3104	100	VRXF-5B-S-100		B1G105	
		TSM3202		200	VRXF-5B-S-200	B1G305			
		TSM3204		400	VRXF-5B-S-400	B1G305			
	Panasonic Corporation	MINAS	A5	MSMD01	100	VRXF-5B-S-100		B1G205	
				MSMD02	200	VRXF-5B-S-200		B1G405	
				MSMF01	100	VRXF-5B-S-100		B1G205	
		A6	MSMF02	200	VRXF-5B-S-200	B1G405			
			OMRON Corporation	OMNUC G5	R88M-K10030	100		VRXF-5B-S-100	B1G105
					R88M-K20030	200		VRXF-5B-S-200	B1G405
	R88M-K40030	400			VRXF-5B-S-400	B1G505			
	1S	R88M-1M10030		100	VRXF-5B-S-100	B1G105			
		R88M-1M20030		200	VRXF-5B-S-200	B1G405			
		R88M-1M40030		400	VRXF-5B-S-400	B1G505			

- Notes: 1. The symbols in the table represent the motor bracket, belt specification reduction gear, and belt specification reduction ratio.
 2. In the table, B1 indicates VRXF-□B (NIDEC-SHIMPO CORPORATION), and B2 indicates VRXF-□C (NIDEC-SHIMPO CORPORATION).
 3. When requesting a product with a reduction gear, please inform THK of the motor model that will be attached.
 4. The table shows only a portion of the model numbers for motors. For details regarding model numbers, please see the catalog for each respective motor manufacturer.
 5. Contact THK if you will be using a motor with a reduction gear.
 6. If the reduction gear's output torque will exceed the permissible input torque (p. 15) due to the maximum torque of the installed motor and the reduction ratio, please consider a safety measure to limit the torque.

Reduction Ratio: 1/9

Motor type	Manufacturer	Series	Motor model	Motor rated output (W)	Reduction gear model	Symbol	Compatible reduction gear coupling	
AC servo motor	YASKAWA Electric Corporation	Σ-V	SGMAV-01	100	VRXF-9B-S-100	B1G109	MJC-33-10X12 (MIGHTY CORPORATION, LTD.)	
			SGMAV-02	200	VRXF-9C-S-200	B2G309	MJC-41-10X19 (MIGHTY CORPORATION, LTD.)	
		Σ-7	SGM7A-01	100	VRXF-9B-S-100	B1G109	MJC-33-10X12 (MIGHTY CORPORATION, LTD.)	
			SGM7A-02	200	VRXF-9C-S-200	B2G309	MJC-41-10X19 (MIGHTY CORPORATION, LTD.)	
		Σ-X	SGMXA-01	100	VRXF-9B-S-100	B1G109	MJC-33-10X12 (MIGHTY CORPORATION, LTD.)	
			SGMXA-02	200	VRXF-9C-S-200	B2G309	MJC-41-10X19 (MIGHTY CORPORATION, LTD.)	
	Mitsubishi Electric Corporation	MELSERVO	J4	HG-KR13	100	VRXF-9B-S-100	B1G109	MJC-33-10X12 (MIGHTY CORPORATION, LTD.)
				HG-MR13		VRXF-9B-S-100	B1G109	MJC-33-10X12 (MIGHTY CORPORATION, LTD.)
				HG-KR23	200	VRXF-9C-S-200	B2G309	MJC-41-10X19 (MIGHTY CORPORATION, LTD.)
			HG-MR23	VRXF-9C-S-200		B2G309	MJC-41-10X19 (MIGHTY CORPORATION, LTD.)	
			J5	HK-KT13W	100	VRXF-9B-S-100	B1G109	MJC-33-10X12 (MIGHTY CORPORATION, LTD.)
				HK-KT23W	200	VRXF-9C-S-200	B2G309	MJC-41-10X19 (MIGHTY CORPORATION, LTD.)
		JN		HF-KN13	100	VRXF-9B-S-100	B1G109	MJC-33-10X12 (MIGHTY CORPORATION, LTD.)
			HF-KN23	200	VRXF-9C-S-200	B2G309	MJC-41-10X19 (MIGHTY CORPORATION, LTD.)	
		TAMAGAWA SEIKI CO., LTD.	TBL-II	TS4603	100	VRXF-9B-S-100	B1G109	MJC-33-10X12 (MIGHTY CORPORATION, LTD.)
	TS4607			200	VRXF-9C-S-200	B2G309	MJC-41-10X19 (MIGHTY CORPORATION, LTD.)	
	TBL-III		TSM3104	100	VRXF-9B-S-100	B1G109	MJC-33-10X12 (MIGHTY CORPORATION, LTD.)	
			TSM3202	200	VRXF-9C-S-200	B2G309	MJC-41-10X19 (MIGHTY CORPORATION, LTD.)	
	Panasonic Corporation	MINAS	A5	MSMD01	100	VRXF-9B-S-100	B1G209	MJC-33-10X12 (MIGHTY CORPORATION, LTD.)
				MSMD02	200	VRXF-9C-S-200	B2G409	MJC-41-10X19 (MIGHTY CORPORATION, LTD.)
			A6	MSMF01	100	VRXF-9B-S-100	B1G209	MJC-33-10X12 (MIGHTY CORPORATION, LTD.)
				MSMF02	200	VRXF-9C-S-200	B2G409	MJC-41-10X19 (MIGHTY CORPORATION, LTD.)
	OMRON Corporation	OMNUC G5	R88M-K10030	100	VRXF-9B-S-100	B1G109	MJC-33-10X12 (MIGHTY CORPORATION, LTD.)	
			R88M-K20030	200	VRXF-9C-S-200	B2G409	MJC-41-10X19 (MIGHTY CORPORATION, LTD.)	
		1S	R88M-1M10030	100	VRXF-9B-S-100	B1G109	MJC-33-10X12 (MIGHTY CORPORATION, LTD.)	
			R88M-1M20030	200	VRXF-9C-S-200	B2G409	MJC-41-10X19 (MIGHTY CORPORATION, LTD.)	

Notes: 1. The symbols in the table represent the motor bracket, belt specification reduction gear, and belt specification reduction ratio.

2. In the table, B1 indicates VRXF-□B (NIDEC-SHIMPO CORPORATION), and B2 indicates VRXF-□C (NIDEC-SHIMPO CORPORATION).

3. When requesting a product with a reduction gear, please inform THK of the motor model that will be attached.

4. The table shows only a portion of the model numbers for motors. For details regarding model numbers, please see the catalog for each respective motor manufacturer.

5. Contact THK if you will be using a motor with a reduction gear.

6. If the reduction gear's output torque will exceed the permissible input torque (p. 15) due to the maximum torque of the installed motor and the reduction ratio, please consider a safety measure to limit the torque.

Options

QZ Lubricator

LM Guide

The QZ Lubricator feeds the right amount of lubricant to the LM rail raceway. This allows an oil film to continuously form between the balls and the raceway, and it significantly extends the lubrication maintenance intervals.

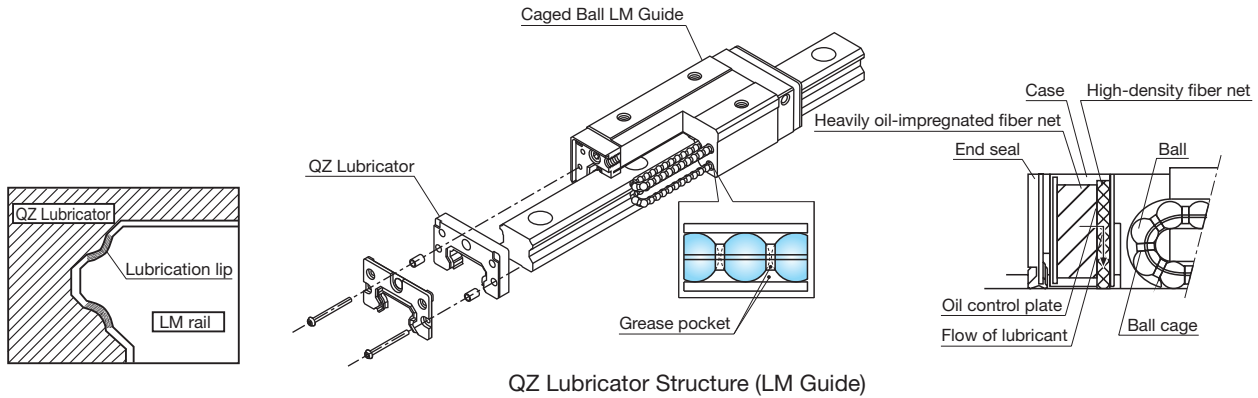

Cover

A simple cover is provided to protect the interior.

The cover is shared between the GL15N and GL20N.

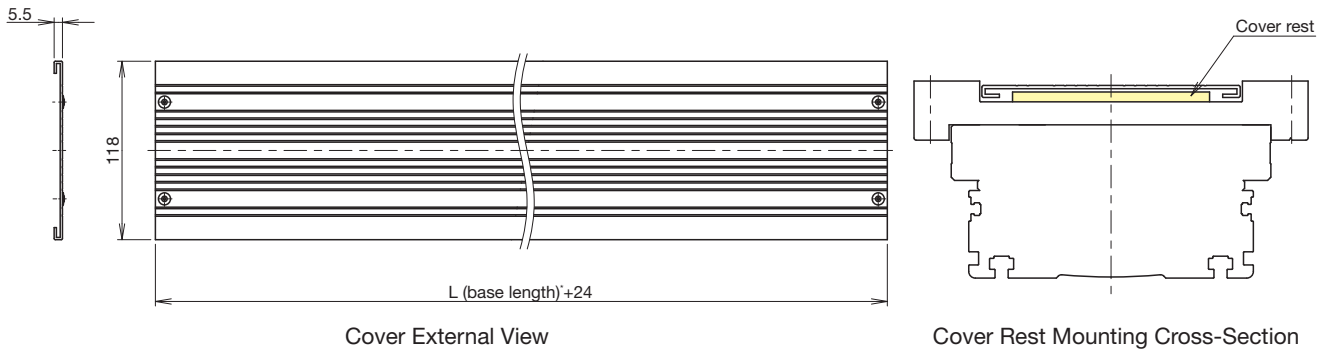

* For base length, see the dimensional table. → p. 17 to 18

Notes: 1. If the base is long, the cover will experience more deflection.

Therefore, to prevent interference with the table, a cover rest is installed on the table as standard for models with base lengths of 1,000 mm or more. (See the figure above.)

However, please note that when the base is long, the deflection of the cover will increase due to its weight, which may cause the cover to come in contact with other components (such as the rail or belt).

2. Take care when using this product in anything other than a horizontal orientation. The deflection of the cover may cause it to come in contact with parts mounted on the table.

Sensors

Optional photo sensors and proximity sensors are available.

Sensors can be mounted using the T-slot on the side of the base.

Symbol	Description	Model	Accessories
N	None	-	-
2	Photo sensors ¹ (x3)	EE-SX671 (OMRON Corporation)	Mounting screws/nuts, sensor dog (x1 or x2), mounting plates (x3)
6	Photo sensors ¹ (x3)	EE-SX674 (OMRON Corporation)	Mounting screws/nuts, sensor dog (x1 or x2), mounting plates (x3)
3	Proximity sensors: N.O. contact ² (x3)	TL-W3MC1 (OMRON Corporation)	Mounting screws/nuts, sensor dog (x1 or x2)
G	Proximity sensors: N.O. contact ² (x1) N.C. contact ³ (x2)	TL-W3MC1 (OMRON Corporation) TL-W3MC2 (OMRON Corporation)	Mounting screws/nuts, sensor dog (x1 or x2)

¹ The photo sensors can be switched between ON when lit and ON when unlit.

Notes: 1. All sensor output is NPN.

² N.O. contact: Normally open contact

2. Sensors and accessories will be mounted to the unit before shipping.

³ N.C. contact: Normally closed contact

Photo Sensor Mounting Dimensions

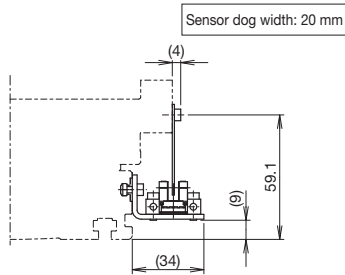

Symbol	Model	Manufacturer
2	EE-SX671	OMRON Corporation

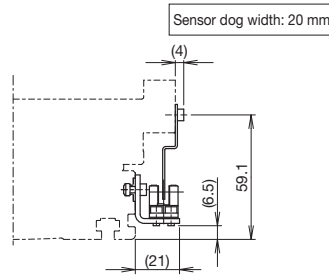

Symbol	Model	Manufacturer
6	EE-SX674	OMRON Corporation

Proximity Sensor Mounting Dimensions

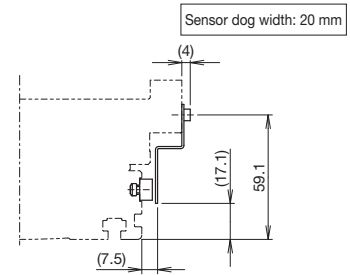

Symbol	Model	Manufacturer
3	TL-W3MC1	OMRON Corporation
G	TL-W3MC1	
	TL-W3MC2	

Cable Carrier

A variety of cable carriers can be mounted using the T-slot on the side of the base.

When selecting a cable carrier, specify the corresponding symbol from the table below.

Symbol	Cable carrier model	Manufacturer
A	TKP0180W40R28	TSUBAKIMOTO CHAIN CO.
B	TKP0180W40R37	
C	TKP0180W40R50	
D	TKP35H22-30W25R37	
E	TKP35H22-30W25R50	

Symbol	Cable carrier model	Manufacturer
F	TKP35H22-30W25R75	TSUBAKIMOTO CHAIN CO.
G	TKP35H22-30W50R37	
H	TKP35H22-30W50R50	
I	TKP35H22-30W50R75	
J	KSH-24L-42	THK CO., LTD.

Note 3: For the selection of the cable carrier, please see the corresponding cable carrier catalog.

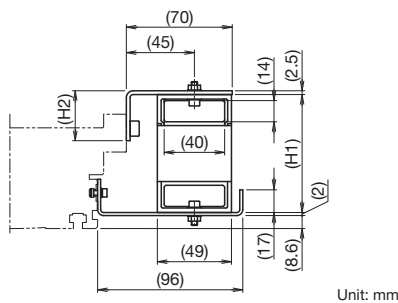

Symbol	Cable carrier model	H1	H2
A	TKP0180W40R28	78	33
B	TKP0180W40R37	96	51
C	TKP0180W40R50	122	77

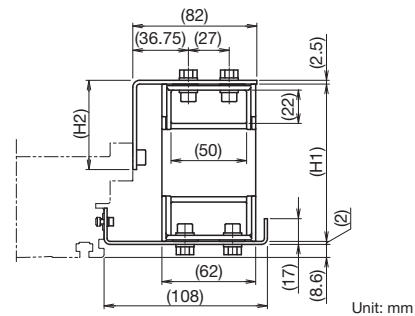

Symbol	Cable carrier model	H1	H2
G	TKP35H22-30W50R37	104	59
H	TKP35H22-30W50R50	130	85
I	TKP35H22-30W50R75	180	135

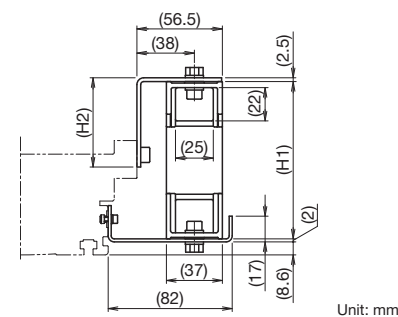

Symbol	Cable carrier model	H1	H2
D	TKP35H22-30W25R37	104	59
E	TKP35H22-30W25R50	130	85
F	TKP35H22-30W25R75	180	135

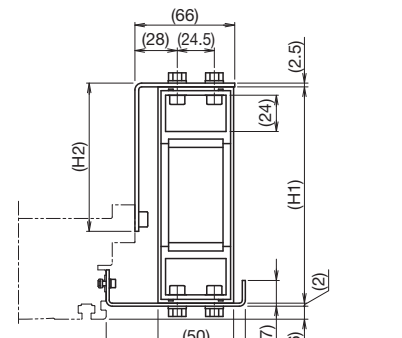

Symbol	Cable carrier model	H1	H2
J	KSH-24L-42	143	98

Options

Bellows

In addition to a cover, bellows are also available as a contamination protection option.

Ball Screw Type

Direct Motor Coupling/Motor Wrap

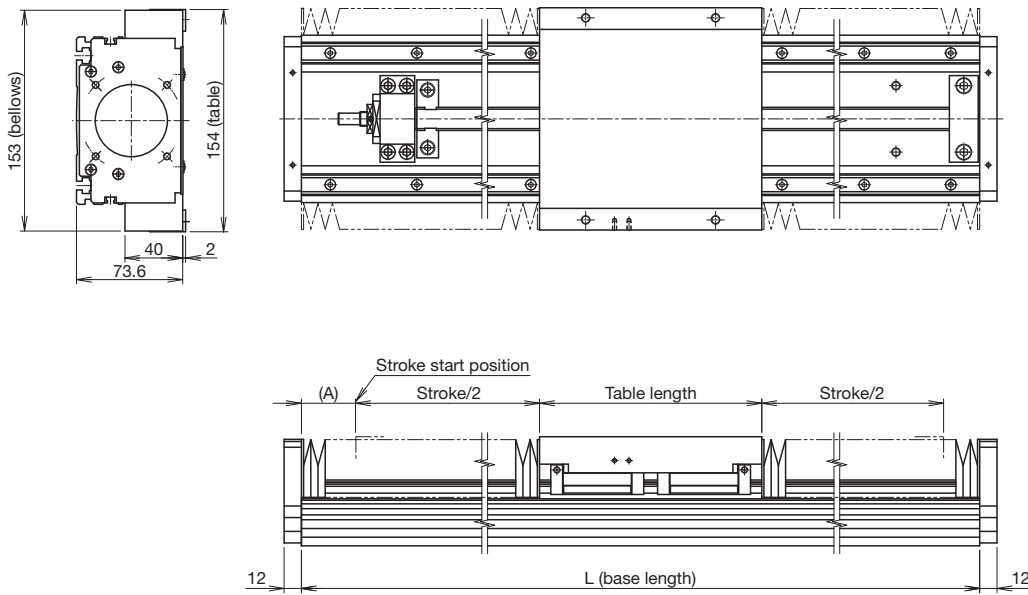

Unit: mm

Table type	Table length
S table	126
L table	154
L (QZ) table	154
L-QZ table	180

Unit: mm

Stroke*	S table	110 (133)	230 (248)	340 (358)	450 (468)	540 (563)	740 (763)	890 (913)	1,040 (1,058)
	L table	100 (119)	215 (234)	320 (340)	420 (440)	515 (535)	715 (735)	865 (885)	1,010 (1,030)
	L (QZ) table	90 (119)	205 (234)	315 (340)	420 (440)	515 (535)	715 (735)	865 (885)	1,010 (1,030)
	L-QZ table	80 (104)	195 (214)	295 (314)	395 (414)	490 (509)	690 (709)	840 (859)	980 (1,004)
L (base length)		340	460	580	700	820	1,060	1,240	1,420
A: Stroke start	S table	60	60	60	60	75	95	110	130
	L table	50	50	50	60	75	95	110	130
	L (QZ) table	60	60	60	60	75	95	110	130
	L-QZ table	40	40	50	60	75	95	110	130

* Values in parentheses are the maximum stroke.

Notes: 1. For the model number coding, use the stroke when bellows are attached.

2. When using bellows, the stroke will be shorter. See the specifications and dimensional diagrams for the stroke when not using bellows. → p. 9 to 10

Belt-Driven Type

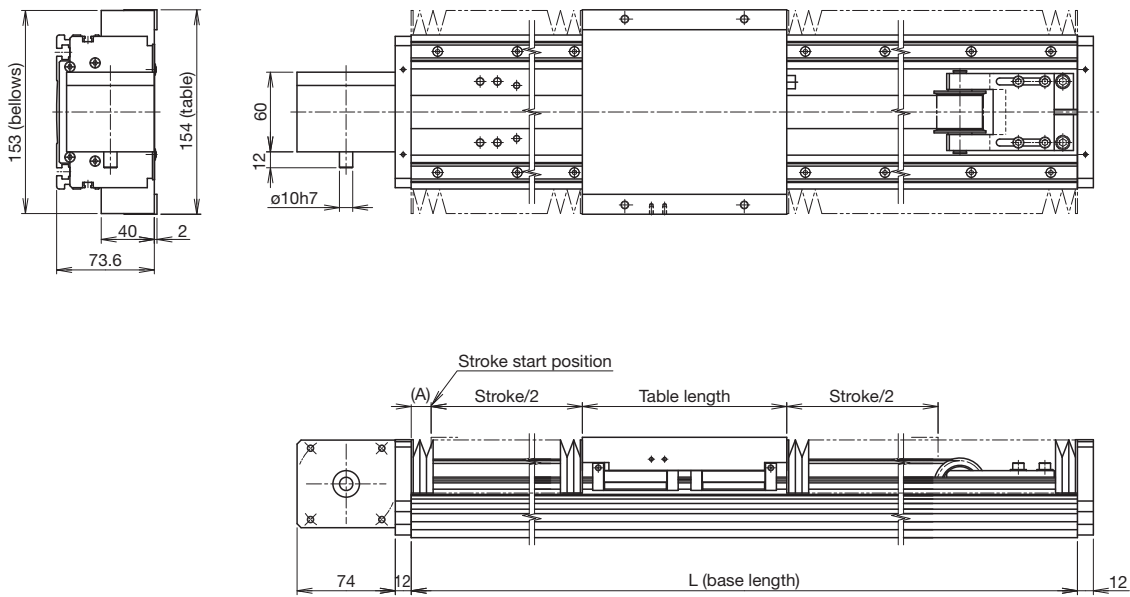

Unit: mm

Table type	Table length
S table	126
L table	154
L-QZ table	180

Unit: mm

Stroke*	S table	270 (291)	380 (396)	480 (501)	680 (698)	810 (833)	950 (973)	1,090 (1,181)	1,220 (1,234)	1,360 (1,378)
	L table	240 (263)	350 (368)	450 (473)	650 (670)	785 (805)	925 (945)	1,060 (1,080)	1,195 (1,215)	1,330 (1,350)
	L-QZ table	220 (237)	320 (342)	430 (447)	620 (644)	760 (779)	900 (919)	1,030 (1,054)	1,170 (1,189)	1,300 (1,324)
L (base length)	580	700	820	1,060	1,240	1,420	1,600	1,780	1,960	
A: Stroke start	70	80	100	130	150	170	190	215	240	

* Values in parentheses are the maximum stroke.

Notes: 1. For the model number coding, use the stroke when bellows are attached.

2. When using bellows, the stroke will be shorter. See the specifications and dimensional diagrams for the stroke when not using bellows. → p. 17 to 18

GL20N



Model Number Coding

Model	Stroke	LM Guide model	LM Guide with/without QZ	Ball screw lead	Ball screw with/without QZ	With/without motor
①	②	③	④	⑤	⑥	⑦
GL20N	1340	SW	Q	B20	Q	0
GL20N	0200: 200 mm to 1540: 1,540 mm	SV: SSR20XV SW: SSR20XW HV: SHS20V	No symbol: Without QZ Q: With QZ	B05: 5 mm B10: 10 mm B20: 20 mm B40: 40 mm	No symbol: Without QZ Q: With QZ	With direct coupling 0: Without motor (Without coupling. If necessary, please specify.) 1: With motor (THK will purchase and mount the motor you specify.) With motor wrap R1: Non-standard side wrap (without motor) R2: Standard side wrap (without motor) R3: Bottom-side wrap (without motor) R4: Non-standard side wrap (THK will purchase and mount the motor you specify.) R5: Standard side wrap (THK will purchase and mount the motor you specify.) R6: Bottom-side wrap (THK will purchase and mount the motor you specify.)

When "J" (with bellows) is selected for ⑨ Cover/bellows, specify the stroke with bellows.
→ p. 41

Please select one of the combinations below.

Table type	③ LM Guide model	④ LM Guide with/without QZ	⑤ Ball screw lead	⑥ Ball screw with/without QZ
S table	SV	No symbol: Without QZ	B□□	No symbol: Without QZ
L table	SW / HV	No symbol: Without QZ	B□□	No symbol: Without QZ
L (QZ)	SW / HV	No symbol: Without QZ	B□□	Q: With QZ
L-QZ	SW / HV	Q: With QZ	B□□	Q: With QZ

If "0" is selected:
No coupling will be attached. Please specify if a coupling is required when ordering.

If "R1," "R2," or "R3" is selected:
The timing pulley and timing belt will be included.

If "1," "R4," "R5," or "R6" is selected:
The designated motor will be mounted. Please specify the motor cable direction separately.
Please select the end plate and motor mounting plate in ⑧ that match the specified motor.

Table Type

The block table type is determined by the LM Guide you select. In addition, the stroke range varies depending on the block table type.

- S table Short table (LM Guide model: SSR20XV)
This type has a shorter table to allow for a longer stroke range.
- L table Long table (LM Guide models: SSR20XW, SHS20V)
This type is optimal for high loads or when loads are positioned away from the center of the table.
- L (QZ) table Long table with QZ Lubricator (LM Guide models: SSR20XW, SHS20V)
A QZ Lubricator is attached to the ball screw.
- L-QZ table Long table with QZ Lubricator (LM Guide models: SSR20XWQZ, SHS20VQZ)
A QZ Lubricator is attached to the LM Guide and ball screw. (This table is longer than an L table. See the dimensional tables on p. 27 to 28.)

⑦ With/Without Motor

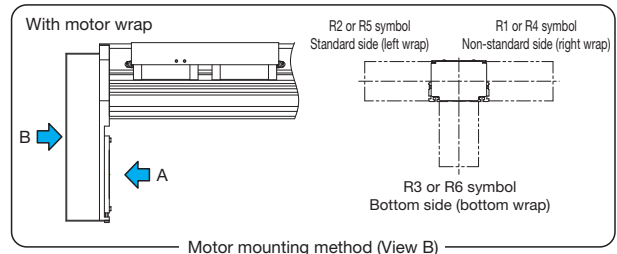

Selection Information

Basic Specifications¹

LM Guide	Basic dynamic load rating C (N)		22,300			
	Basic static load rating C ₀ (N)		38,400			
Ball screw	Ball screw lead (mm)		5	10	20	40
	Basic dynamic load rating C _a (N)		6,000	9,800	7,700	5,400
	Basic static load rating C _{0a} (N)		16,500	25,200	22,300	13,600
	Screw shaft diameter (mm)		Ø20	Ø15	Ø20	Ø20
	Thread minor diameter (mm)		Ø17.2	Ø12.5	Ø17.5	Ø17.5
	Ball center-to-center diameter (mm)		Ø20.5	Ø15.75	Ø20.75	Ø20.75
	Permissible rotational speed ² (min ⁻¹)		4,800	4,440		3,370
Bearing (fixed side)	Axial direction	Basic dynamic load rating C _a (N)	6,650			
		Static permissible load P _{0a} (N)	2,200			
Base	Geometric moment of inertia ³	I _x ⁴ (mm ⁴)	3.15×10 ⁵			
		I _y ⁵ (mm ⁴)	4.28×10 ⁶			
		Mass (kg/m)	6.5			
Starting torque ⁶ (N-cm)	Ball screw QZ	Without QZ	17	14.5	23.6	32.5
		With QZ	30.8	40.7	48.5	58.1
Positioning repeatability (mm)		±0.02				
Backlash (mm)		0.05				
Permissible input torque (N-m)	Direct coupling	2	4	5.3		
	Motor wrap	2	4	4.6		
Static permissible load ⁷ (N)	Reverse-radial direction	14,300				
	Horizontal direction	4,500				
	Axial direction	2,200				
Static permissible moment ⁸ (N-m)	LM Guide QZ	Without QZ	M _a : 710, M _B : 430, M _C : 1,180			
		With QZ	M _a : 1,070, M _B : 500, M _C : 1,180			
Standard grease/ Grease nipple used	LM Guide	THK AFB-LF Grease/B-M6F				
	Ball screw	THK AFB-LF Grease/Without nipple				

Static Permissible Moment

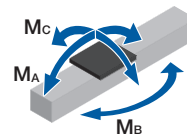

Static Permissible Load

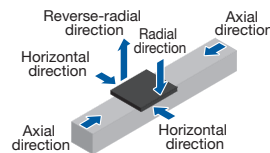

Geometric Moment of Inertia

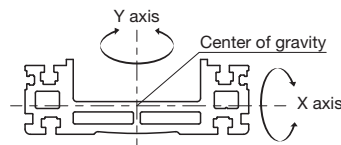

¹ These are the values for LM Guide model HV: SHS20V specifications.
² The permissible rotational speed may decrease as the stroke becomes longer.
³ These are the values for the cross-sectional characteristics of the aluminum base.
⁴ I_x is the geometric moment of inertia about the X axis.
⁵ I_y is the geometric moment of inertia about the Y axis.
⁶ The starting torque refers to the values when AFB LF Grease is used.
⁷ The static permissible load is a value limited by the bolt tightening strength, the basic static load rating of the LM Guide unit and the ball screw unit, and the static permissible load of the bearing.
⁸ Static permissible moment is the maximum moment that can be permitted while the product is stationary.
 The reference for M_a and M_c moments is the top surface of the table, while the reference for M_B moments is the center of the table.

End plate/motor mounting plate ⑧	Cover/ bellows ⑨	Sensor ⑩	Cable carrier ⑪
B	C	2	J
With direct coupling	N: Without cover C: With cover J: With bellows	N: None 2 3 6 G	N: None A B C D E F G H I J
A B E F H I	With cover → p. 31 With bellows → p. 41	Sensors → p. 32	
With motor wrap			
B14 F11 F14			
End plate → p. 29			Cable carrier → p. 32

Motor Selection Information

■ LM Guide

LM Guide model	Moving part mass (kg)	Sliding resistance (N)
GL20N*-SV (SSR20XV)	2.7	21
GL20N*-SW (SSR20XW)	3.2	21.4
GL20N*-SWQ (SSR20XWQZ)	3.4	33.4
GL20N*-HV (SHS20V)	3	20.6
GL20N*-HVQ (SHS20VQZ)	3.8	36.6

■ Ball Screw

Base length ¹ (mm)	Lead (mm)	Ball screw model	Shaft length ² (mm)
460 to 1,780	5	BTK2005V-2.6ZZ	427 to 1,747
	10	BLK1510-5.6ZZ	
	20	BLK2020-3.6ZZ	
	40	WTF2040-2ZZ	

■ Motor Mounting Part

Direct coupling Shaft end diameter (mm)	Motor wrap Timing pulley Inertial moment x 10 ⁻⁴ (kg·m ²)	
	Ø10h7	0.12

¹ For base length, see the dimensional table. → p. 27 to 28
² This length is that of a ball screw shaft directly coupled to the motor.
 For motor wrap specifications, the ball screw shaft is 74 mm longer.
 Note: Please see p. 29 for information on applicable couplings.

Permissible Overhang Length³

Horizontal

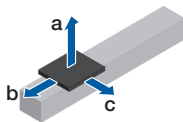

Wall-Mounted

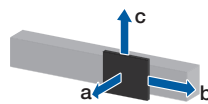

Vertical

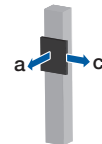

200 W	Ball screw lead (mm)	Load mass (kg)	a (mm)	b (mm)	c (mm)
Direct coupling/ Motor wrap	5	17.5	1,300	1,300	1,300
		35	1,300	1,300	1,300
		70	1,300	860	1,120
	10	17.5	1,300	1,300	1,300
		35	1,300	1,300	1,300
		70	1,300	670	860
	20	7	1,300	1,300	1,300
		14.5	1,300	1,300	1,300
		29	1,300	1,300	1,300

200 W	Ball screw lead (mm)	Load mass (kg)	a (mm)	b (mm)	c (mm)
Direct coupling/ Motor wrap	5	17.5	1,300	1,300	1,300
		35	1,300	1,300	1,300
		70	1,090	830	1,300
	10	17.5	1,300	1,300	1,300
		35	1,300	1,300	1,300
		70	840	640	1,300
	20	7	1,300	1,300	1,300
		14.5	1,300	1,300	1,300
		29	1,300	1,300	1,300

200 W	Ball screw lead (mm)	Load mass (kg)	a (mm)	c (mm)
Direct coupling/ Motor wrap	5	5.5	1,300	1,300
		11.5	1,300	1,300
		23	1,300	1,300
	10	3.5	1,300	1,300
		7.5	1,300	1,300
		15	1,300	1,300
	20	1.5	1,300	1,300
		3	1,300	1,300
		6	1,300	1,300

400 W	Ball screw lead (mm)	Load mass (kg)	a (mm)	b (mm)	c (mm)
Direct coupling/ Motor wrap	20	15	1,300	1,300	1,300
		30	1,300	1,290	1,300
		60	1,300	620	740
	40	3	1,300	1,300	1,300
		6.5	1,300	1,300	1,300
		13	1,300	1,300	1,300

400 W	Ball screw lead (mm)	Load mass (kg)	a (mm)	b (mm)	c (mm)
Direct coupling/ Motor wrap	20	15	1,300	1,300	1,300
		30	1,300	1,260	1,300
		60	740	590	1,300
	40	3	1,300	1,300	1,300
		6.5	1,300	1,300	1,300
		13	1,300	1,300	1,300

400 W	Ball screw lead (mm)	Load mass (kg)	a (mm)	c (mm)
Direct coupling/ Motor wrap	20	3.5	1,300	1,300
		7.5	1,300	1,300
		15	1,300	1,300
	40	1.5	1,300	1,300
		3	1,300	1,300
		6	1,300	1,300

³ This is the value with the travel life of the LM Guide limited to 10,000 km (5,000 km for leads of 5 mm only). The calculation conditions are as follows.
 Stroke: 870 mm (LM Guide: SHS20V) / Acceleration/deceleration: 0.3 G / Speed: Rated speed / Overhang direction: Loaded only in a single direction. Dimensions a, b, and c are from the center of the table's upper surface.

Dimensions

Direct Motor Coupling

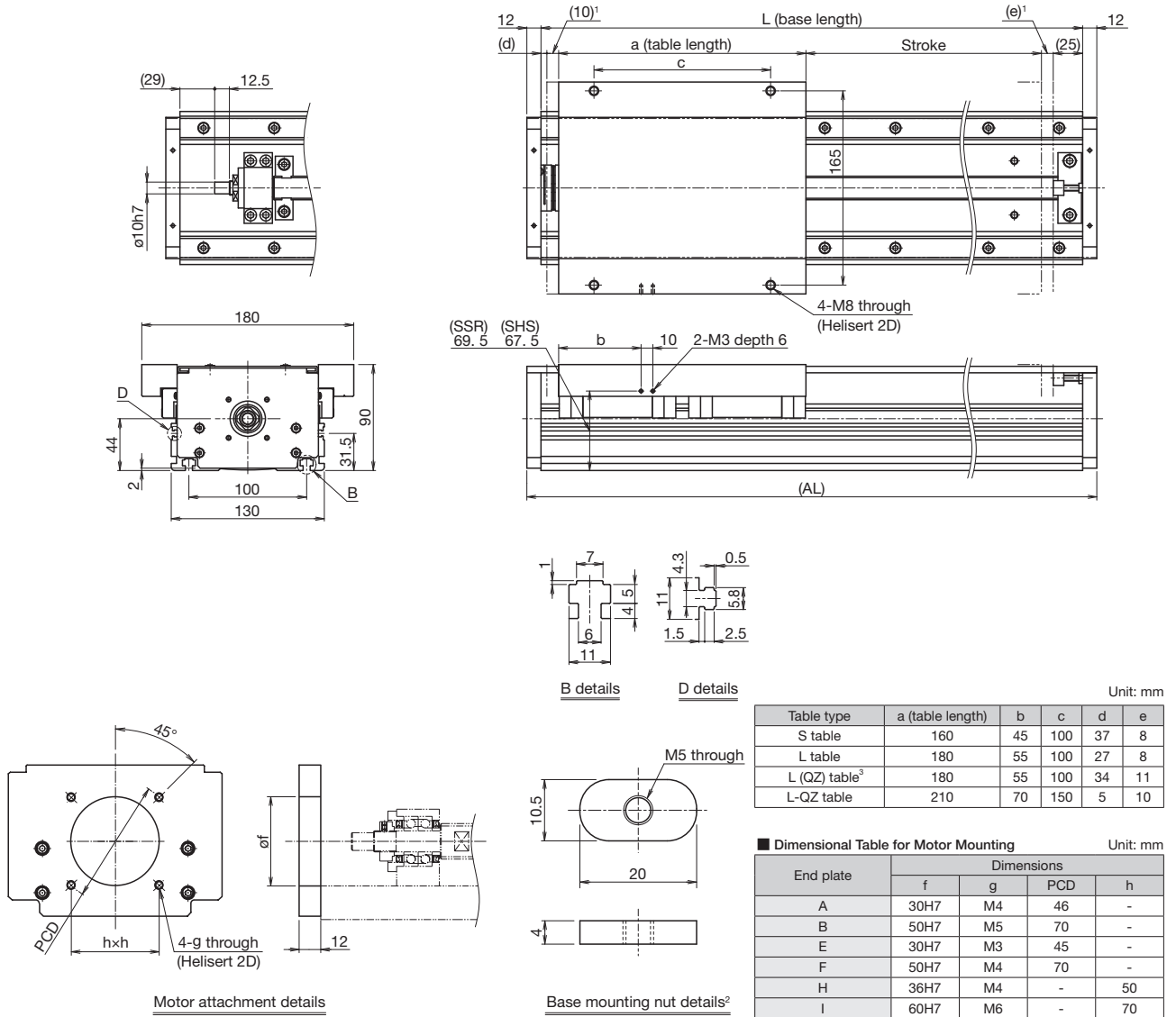

Stroke (mm) (Stroke between mechanical stoppers)	S table	220 (238)	340 (358)	460 (478)	580 (598)	820 (838)	1,000 (1,018)	1,180 (1,198)	1,360 (1,378)	1,540 (1,558)
	L table	210 (228)	330 (348)	450 (468)	570 (588)	810 (828)	990 (1,008)	1,170 (1,188)	1,350 (1,368)	1,530 (1,548)
L (QZ) table ³	200 (221)	320 (341)	440 (461)	560 (581)	800 (821)	980 (1,001)	1,160 (1,181)	1,340 (1,361)	1,520 (1,541)	
L-QZ table	200 (220)	320 (340)	440 (460)	560 (580)	800 (820)	980 (1,000)	1,160 (1,180)	1,340 (1,360)	1,520 (1,540)	
Maximum speed ⁴ (mm/s)	Ball screw lead: 5 mm	400				250	180	130	100	80
	Ball screw lead: 10 mm	740				700	380	260	190	-
	Ball screw lead: 20 mm	1,120				1,060	740	540	410	330
	Ball screw lead: 40 mm	2,240				2,120	1,480	1,090	830	660
Dimensions (mm)	L (base length)	460	580	700	820	1,060	1,240	1,420	1,600	1,780
	AL	484	604	724	844	1,084	1,264	1,444	1,624	1,804
Nuts for mounting the base		4	6	6	8	10	10	12	14	14
Mass ⁵ (kg)	L-QZ table (SHS20V)	11.4	13.1	14.8	16.5	19.9	22.4	24.9	27.5	30

³ Indicates QZ specifications for the ball screw only.
⁴ The maximum speed is restricted by the permissible speed of the actuator.
⁵ The mass is that of products with a cover and QZ.
 Note: The maximum manufacturing length for the base with a 10 mm ball screw lead is 1,420 mm.

Dimensions

Motor Wrap

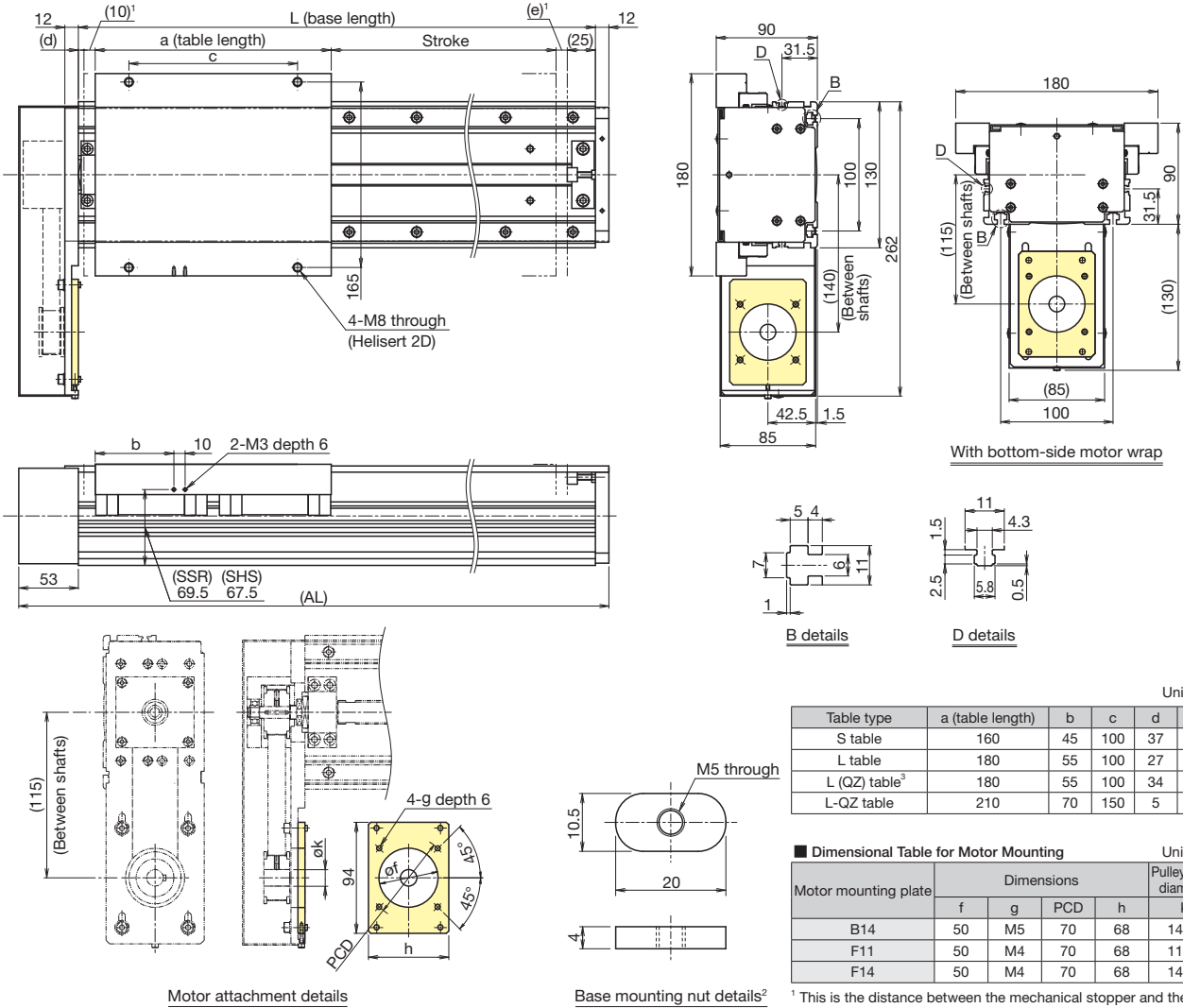

Unit: mm

Table type	a (table length)	b	c	d	e
S table	160	45	100	37	8
L table	180	55	100	27	8
L (QZ) table ³	180	55	100	34	11
L-QZ table	210	70	150	5	10

■ Dimensional Table for Motor Mounting Unit: mm

Motor mounting plate	Dimensions				Pulley inner diameter
	f	g	PCD	h	
B14	50	M5	70	68	14H7
F11	50	M4	70	68	11H7
F14	50	M4	70	68	14H7

- ¹ This is the distance between the mechanical stopper and the stroke starting position.
- ² Nuts for mounting the base are included. The quantity is listed in the dimensional table.
- ³ Indicates QZ specifications for the ball screw only.

Stroke (mm) (Stroke between mechanical stoppers)	S table	220 (238)	340 (358)	460 (478)	580 (598)	820 (838)	1,000 (1,018)	1,180 (1,198)	1,360 (1,378)	1,540 (1,558)
	L table	210 (228)	330 (348)	450 (468)	570 (588)	810 (828)	990 (1,008)	1,170 (1,188)	1,350 (1,368)	1,530 (1,548)
	L (QZ) table ³	200 (221)	320 (341)	440 (461)	560 (581)	800 (821)	980 (1,001)	1,160 (1,181)	1,340 (1,361)	1,520 (1,541)
	L-QZ table	200 (220)	320 (340)	440 (460)	560 (580)	800 (820)	980 (1,000)	1,160 (1,180)	1,340 (1,360)	1,520 (1,540)
Maximum speed ⁴ (mm/s)	Ball screw lead: 5 mm	400				250	180	130	100	80
	Ball screw lead: 10 mm	740				700	380	260	190	-
	Ball screw lead: 20 mm	1,120				1,060	740	540	410	330
	Ball screw lead: 40 mm	2,240				2,120	1,480	1,090	830	660
Dimensions (mm)	L (base length)	460	580	700	820	1,060	1,240	1,420	1,600	1,780
	AL	525	645	765	885	1,125	1,305	1,485	1,665	1,845
Nuts for mounting the base		4	6	6	8	10	10	12	14	14
Mass ⁵ (kg)	L-QZ table (SHS20V)	13.3	15	16.7	18.4	21.8	24.3	26.8	29.4	31.9

³ Indicates QZ specifications for the ball screw only.
⁴ The maximum speed is restricted by the permissible speed of the actuator.
⁵ The mass is that of products with a cover and QZ.
 Note: The maximum manufacturing length for the base with a 10 mm ball screw lead is 1,420 mm.

Options

End Plate (Direct Coupling)

Several types of end plate for mounting motors are available.
Specify an end plate that matches the motor used.

Motor type	Manufacturer	Series	Motor model	Motor rated output (W)	Flange size	End plate	Compatible coupling model		
							MIKI PULLEY CO., LTD.	Nabeya Bi-tech Kaisha (NBK)	
AC servo motor	YASKAWA Electric Corporation	Σ-V	SGMJV-01	100	40×40	A	SFC-020DA2-8B-10B-L38	XGT2-25C-8-10	
			SGMAV-01						
			SGMJV-02	200	60×60	B	SFC-030DA2-10B-14B	XGT2-27C-10-14	
			SGMAV-02						
			SGMJV-04	400	60×60	B	SFC-035DA2-10B-14B	XGT2-30C-10-14	
			SGMAV-04						
		Σ-7	SGM7J-01	100	40×40	A	SFC-020DA2-8B-10B-L38	XGT2-25C-8-10	
			SGM7A-01						
			SGM7J-02	200	60×60	B	SFC-030DA2-10B-14B	XGT2-27C-10-14	
			SGM7A-02						
			SGM7J-04	400	60×60	B	SFC-035DA2-10B-14B	XGT2-30C-10-14	
			SGM7A-04						
	Σ-X	SGMXJ-01	100	40×40	A	SFC-020DA2-8B-10B-L38	XGT2-25C-8-10		
		SGMXA-01							
		SGMXJ-02	200	60×60	B	SFC-030DA2-10B-14B	XGT2-27C-10-14		
		SGMXA-02							
		SGMXJ-04	400	60×60	B	SFC-035DA2-10B-14B	XGT2-30C-10-14		
		SGMXA-04							
	Mitsubishi Electric Corporation	MELSERVO	J4	HG-KR13	100	40×40	A	SFC-020DA2-8B-10B-L38	XGT2-25C-8-10
				HG-MR13					
				HG-KR23	200	60×60	B	SFC-030DA2-10B-14B	XGT2-27C-10-14
			HG-MR23						
			HG-KR43	400	60×60	B	SFC-035DA2-10B-14B	XGT2-30C-10-14	
			HG-MR43						
		J5	HK-KT13W	100	40×40	A	SFC-020DA2-8B-10B-L38	XGT2-25C-8-10	
			HK-KT23W	200	60×60	B	SFC-030DA2-10B-14B	XGT2-27C-10-14	
			HK-KT43W	400	60×60	B	SFC-035DA2-10B-14B	XGT2-30C-10-14	
		JN	HF-KN13	100	40×40	A	SFC-020DA2-8B-10B-L38	XGT2-25C-8-10	
			HF-KN23	200	60×60	B	SFC-030DA2-10B-14B	XGT2-27C-10-14	
			HF-KN43	400	60×60	B	SFC-035DA2-10B-14B	XGT2-30C-10-14	
	TAMAGAWA SEIKI CO., LTD.	TBL-II	TS4603	100	40×40	A	SFC-020DA2-8B-10B-L38	XGT2-25C-8-10	
			TS4607	200	60×60	B	SFC-030DA2-10B-14B	XGT2-27C-10-14	
			TS4609	400	60×60	B	SFC-035DA2-10B-14B	XGT2-30C-10-14	
		TBL-IV	TSM3104	100	40×40	A	SFC-020DA2-8B-10B-L38	XGT2-25C-8-10	
			TSM3202	200	60×60	B	SFC-030DA2-10B-14B	XGT2-27C-10-14	
			TSM3204	400	60×60	B	SFC-035DA2-10B-14B	XGT2-30C-10-14	
	Panasonic Corporation	MINAS	A5	MSMD01	100	38×38	E	SFC-020DA2-8B-10B-L38	XGT2-25C-8-10
				MSME01					
				MSMD02	200	60×60	F	SFC-030DA2-10B-11B	XGT2-30C-10-11
			MSME02						
			MSMD04	400	60×60	F	SFC-035DA2-10B-14B	XGT2-30C-10-14	
			MSME04						
		A6	MSMF01	100	38×38	E	SFC-020DA2-8B-10B-L38	XGT2-25C-8-10	
			MHMF01		40×40	A	SFC-020DA2-8B-10B-L38	XGT2-25C-8-10	
			MSMF02	200	60×60	F	SFC-030DA2-10B-11B	XGT2-30C-10-11	
		MHMF02							
		MSMF04	400	60×60	F	SFC-035DA2-10B-14B	XGT2-30C-10-14		
		MHMF04							
KEYENCE CORPORATION	SV	SV-M010	100	40×40	A	SFC-020DA2-8B-10B-L38	XGT2-25C-8-10		
		SV-M020	200	60×60	B	SFC-030DA2-10B-14B	XGT2-27C-10-14		
		SV-M040	400	60×60	B	SFC-035DA2-10B-14B	XGT2-30C-10-14		
	SV2	SV2-M010	100	40×40	A	SFC-020DA2-8B-10B-L38	XGT2-25C-8-10		
		SV2-M020	200	60×60	B	SFC-030DA2-10B-14B	XGT2-27C-10-14		
		SV2-M040	400	60×60	B	SFC-035DA2-10B-14B	XGT2-30C-10-14		
SANYO DENKI CO., LTD.	SANMOTION R	R2□A04010	100	40×40	A	SFC-020DA2-8B-10B-L38	XGT2-25C-8-10		
		R2□A06020	200	60×60	B	SFC-030DA2-10B-14B	XGT2-27C-10-14		
		R2AA06040	400	60×60	B	SFC-035DA2-10B-14B	XGT2-30C-10-14		
OMRON Corporation	OMNUC G5	R88M-K10030	100	40×40	A	SFC-020DA2-8B-10B-L38	XGT2-25C-8-10		
		R88M-K20030	200	60×60	F	SFC-030DA2-10B-11B	XGT2-30C-10-11		
		R88M-K40030	400	60×60	F	SFC-035DA2-10B-14B	XGT2-30C-10-14		
	1S	R88M-1M10030	100	40×40	A	SFC-020DA2-8B-10B-L38	XGT2-25C-8-10		
		R88M-1M20030	200	60×60	F	SFC-030DA2-10B-11B	XGT2-30C-10-11		
		R88M-1M40030	400	60×60	F	SFC-035DA2-10B-14B	XGT2-30C-10-14		

Motor type	Manufacturer	Series	Motor model	Flange size	End plate	Compatible coupling model		
						MIKI PULLEY CO., LTD.	Nabeya Bi-tech Kaisha (NBK)	
Stepper motor	ORIENTAL MOTOR CO., LTD.	αStep	AZ6*, AR6*	60×60	H	SFC-025DA2-10B-10B-L43	XGT2-25C-10-10	
			AZ9*, AR9*	85×85	I	SFC-025DA2-10B-14B-L43	XGT2-27C-10-14	
		5-phase	CRK*	CRK56* (CRK569PM*)	60×60	H	SFC-025DA2-10B-10B-L43 (SFC-025DA2-10B-10B-L43)	XGT2-25C-8-10 (XGT2-25C-10-10)
			RK II	RKS56*	60×60	H	SFC-025DA2-10B-10B-L43	XGT2-25C-10-10
			RKS59*	85×85	I	SFC-025DA2-10B-14B-L43	XGT2-34C-10-14	
	KEYENCE CORPORATION	2-phase	QS-M60	60×60	H	SFC-025DA2-8B-10B-L43	XGT2-25C-8-10	
		PB	PBDM60*, PBA**60*	60×60	H	SFC-025DA2-10B-10B-L43	XGL2-25C-10-10	
	SANYO DENKI CO., LTD.	5-phase	FAM56*/FDM56*/FA512M60/FB512M60	60×60	H	SFC-025DA2-10B-10B-L43	XGT2-25C-10-10	
		2-phase	DB16H78*	60×60	H	SFC-025DA2-8B-10B-L43	XGL2-25C-8-10	

* When specifying a coupling, note that the motor axis diameter is different for models in parentheses.
Notes: 1. The table shows only a portion of the model numbers for motors. For details regarding model numbers, please see the catalog for each respective motor manufacturer.
2. If the maximum torque of the installed motor will exceed the permissible input torque (p. 25), please consider a safety measure to limit the torque.

Motor Mounting Plate (Motor Wrap)

Motor mounting plates are available for attaching a variety of motors.

Specify a motor mounting plate that matches the motor used.

Motor type	Manufacturer	Series	Motor model	Motor rated output (W)	Flange size	Motor mounting plate	
AC servo motor	YASKAWA Electric Corporation	Σ-V	SGMJV-02	200	60×60	B14	
			SGMAV-02				
			SGMJV-04	400	60×60	B14	
			SGMAV-04				
		Σ-7	SGM7J-02	200	60×60	B14	
			SGM7A-02				
			SGM7J-04	400	60×60	B14	
			SGM7A-04				
		Σ-X	SGMXJ-02	200	60×60	B14	
			SGMXA-02				
			SGMXJ-04	400	60×60	B14	
			SGMXA-04				
	Mitsubishi Electric Corporation	MELSERVO	J4	HG-KR23	200	60×60	B14
				HG-MR23			
				HG-KR43	400	60×60	B14
			HG-MR43				
		J5	HK-KT23W	200	60×60	B14	
			HK-KT43W	400	60×60	B14	
		JN	HF-KN23	200	60×60	B14	
			HF-KN43	400	60×60	B14	
	TAMAGAWA SEIKI CO., LTD.	TBL-iII	TS4607	200	60×60	B14	
			TS4609	400	60×60	B14	
		TBL-iIV	TSM3202	200	60×60	B14	
			TSM3204	400	60×60	B14	
	Panasonic Corporation	MINAS	A5	MSMD02	200	60×60	F11
				MSME02			
				MSMD04	400	60×60	F14
				MSME04			
		A6	MSMF02	200	60×60	F11	
			MHMF02				
			MSMF04	400	60×60	F14	
			MHMF04				
	KEYENCE CORPORATION	SV	SV-M020	200	60×60	B14	
			SV-M040	400	60×60	B14	
		SV2	SV2-M020	200	60×60	B14	
			SV2-M040	400	60×60	B14	
SANYO DENKI CO., LTD.	SANMOTION R	R2□A06020	200	60×60	B14		
		R2AA06040	400	60×60	B14		
OMRON Corporation	OMNUC G5	R88M-K20030	200	60×60	F11		
		R88M-K40030	400	60×60	F14		
	1S	R88M-1M20030	200	60×60	F11		
		R88M-1M40030	400	60×60	F14		

Notes: 1. The table shows only a portion of the model numbers for motors. For details regarding model numbers, please see the catalog for each respective motor manufacturer. Please select a motor shaft with a keyed end.

2. If the maximum torque of the installed motor will exceed the permissible input torque (p. 25), please consider a safety measure to limit the torque.

Options

QZ Lubricator

LM Guide

The QZ Lubricator feeds the right amount of lubricant to the LM rail raceway. This allows an oil film to continuously form between the balls and the raceway, and it significantly extends the lubrication maintenance intervals.

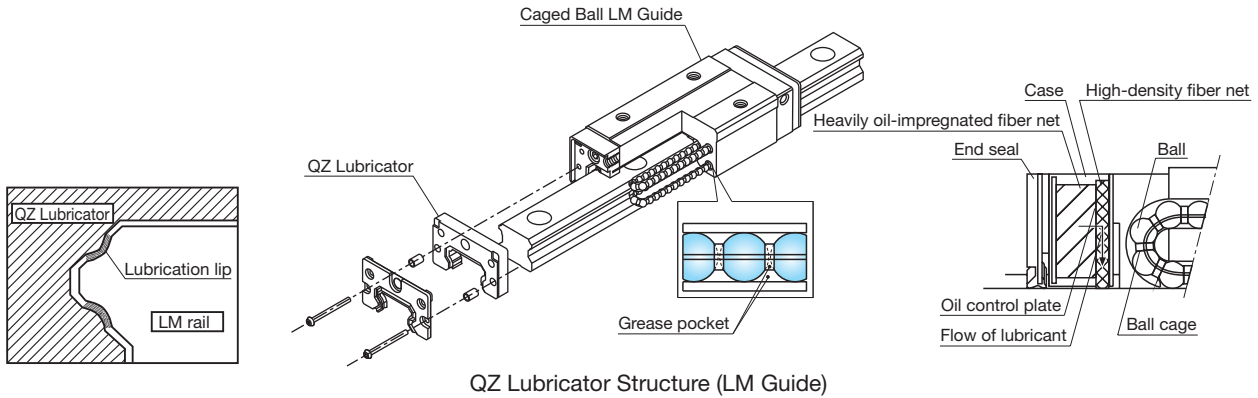

Ball Screw

The QZ Lubricator feeds the right amount of lubricant to the ball screw shaft raceway. This allows an oil film to continuously form between the balls and the raceway, and it significantly extends the lubrication maintenance intervals.

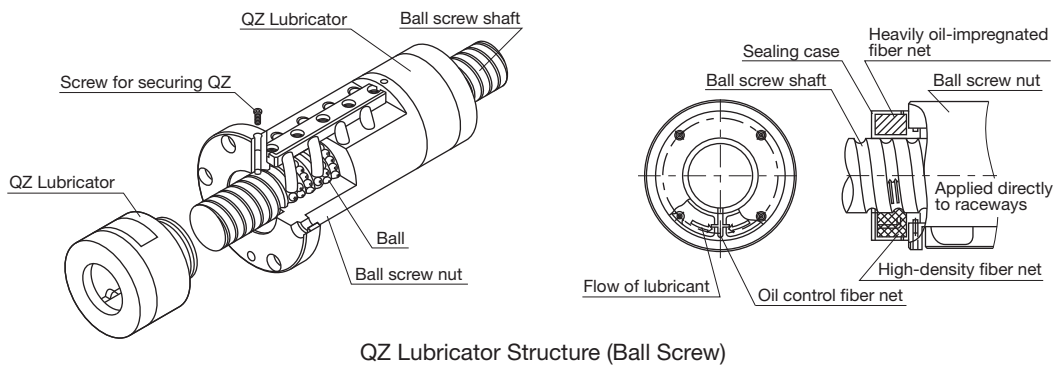

Cover

A simple cover is provided to protect the interior. The cover is shared between the GL15N and GL20N.

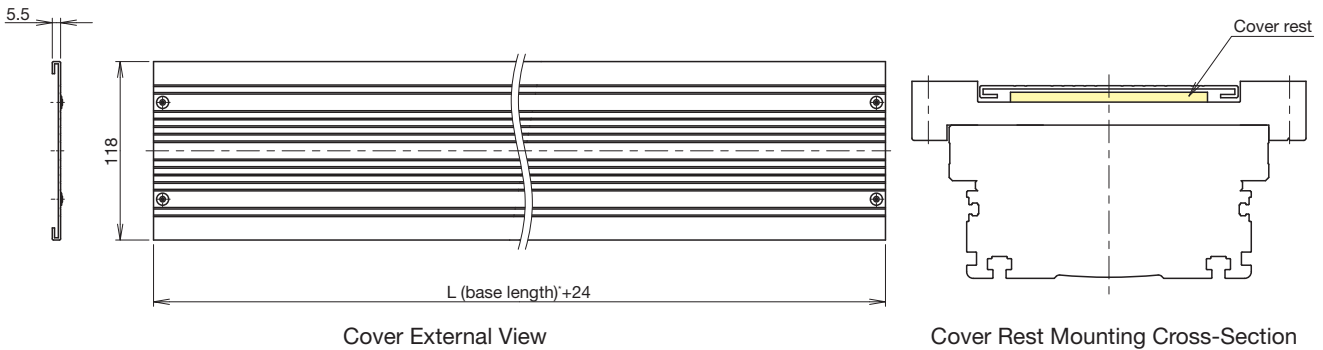

* For base length, see the dimensional table. → p. 27 to 28

Notes: 1. If the base is long, the cover will experience more deflection.

Therefore, to prevent interference with the table, a cover rest is installed on the table as standard for models with base lengths of 1,000 mm or more. (See the figure above.)

However, please note that when the base is long, the deflection of the cover will increase due to its weight, which may cause the cover to come in contact with other components (such as the rail or belt).

2. Take care when using this product in anything other than a horizontal orientation. The deflection of the cover may cause it to come in contact with parts mounted on the table.

Sensors

Optional photo sensors and proximity sensors are available.

Sensors can be mounted using the T-slot on the side of the base.

Symbol	Description	Model	Accessories
N	None	-	-
2	Photo sensors ¹ (x3)	EE-SX671 (OMRON Corporation)	Mounting screws/nuts, sensor dog (x1 or x2), mounting plates (x3)
6	Photo sensors ¹ (x3)	EE-SX674 (OMRON Corporation)	Mounting screws/nuts, sensor dog (x1 or x2), mounting plates (x3)
3	Proximity sensors: N.O. contact ² (x3)	TL-W3MC1 (OMRON Corporation)	Mounting screws/nuts, sensor dog (x1 or x2)
G	Proximity sensors: N.O. contact ² (x1) N.C. contact ³ (x2)	TL-W3MC1 (OMRON Corporation) TL-W3MC2 (OMRON Corporation)	Mounting screws/nuts, sensor dog (x1 or x2)

¹ The photo sensors can be switched between ON when lit and ON when unlit.

Notes: 1. All sensor output is NPN.

² N.O. contact: Normally open contact

2. Sensors and accessories will be mounted to the unit before shipping.

³ N.C. contact: Normally closed contact

Photo Sensor Mounting Dimensions

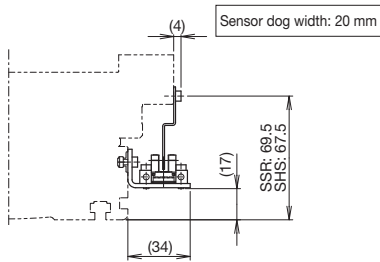

Symbol	Model	Manufacturer
2	EE-SX671	OMRON Corporation

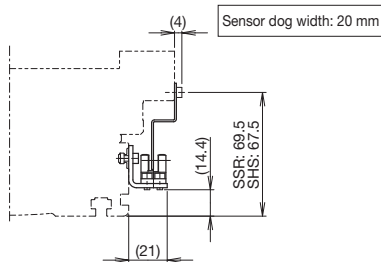

Symbol	Model	Manufacturer
6	EE-SX674	OMRON Corporation

Proximity Sensor Mounting Dimensions

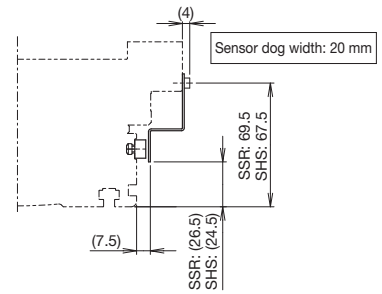

Symbol	Model	Manufacturer
3	TL-W3MC1	OMRON Corporation
G	TL-W3MC1 TL-W3MC2	

Cable Carrier

A variety of cable carriers can be mounted using the T-slot on the side of the base.

When selecting a cable carrier, specify the corresponding symbol from the table below.

Symbol	Cable carrier model	Manufacturer
A	TKP0180W40R28	TSUBAKIMOTO CHAIN CO.
B	TKP0180W40R37	
C	TKP0180W40R50	
D	TKP35H22-30W25R37	
E	TKP35H22-30W25R50	

Symbol	Cable carrier model	Manufacturer
F	TKP35H22-30W25R75	TSUBAKIMOTO CHAIN CO.
G	TKP35H22-30W50R37	
H	TKP35H22-30W50R50	
I	TKP35H22-30W50R75	
J	KSH-24L-42	THK CO., LTD.

Note 3: For the selection of the cable carrier, please see the corresponding cable carrier catalog.

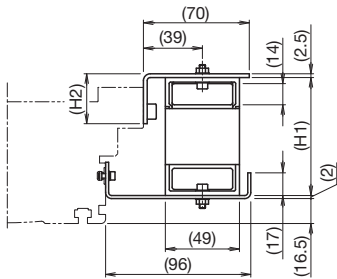

Symbol	Cable carrier model	H1	H2
A	TKP0180W40R28	78	33
B	TKP0180W40R37	96	51
C	TKP0180W40R50	122	77

Unit: mm

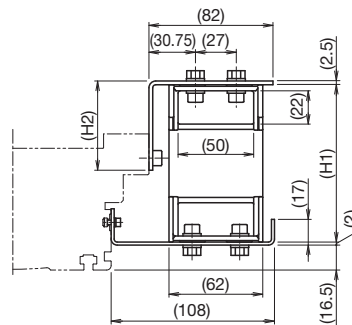

Symbol	Cable carrier model	H1	H2
G	TKP35H22-30W50R37	104	59
H	TKP35H22-30W50R50	130	85
I	TKP35H22-30W50R75	180	135

Unit: mm

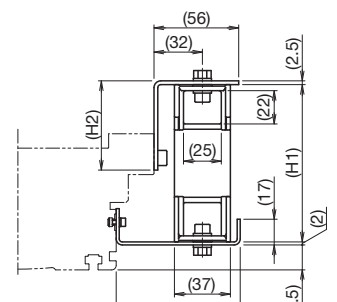

Symbol	Cable carrier model	H1	H2
D	TKP35H22-30W25R37	104	59
E	TKP35H22-30W25R50	130	85
F	TKP35H22-30W25R75	180	135

Unit: mm

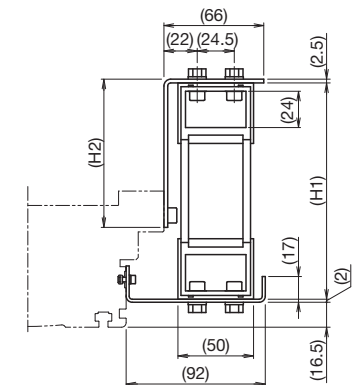

Symbol	Cable carrier model	H1	H2
J	KSH-24L-42	143	98

Unit: mm

GL20N

Direct motor coupling	Width 180 mm	Height 90 mm	Max. stroke 2,700 mm	Max. speed 2,000 mm/s	Belt-driven type
-----------------------	--------------	--------------	----------------------	-----------------------	------------------

Model Number Coding

Model ①	Stroke ②	LM Guide model ③	LM Guide with/without QZ ④	Drive system ⑤	With/without motor ⑥	Motor bracket ⑦
GL20N	2150	SW	Q	EH	0	B1
GL20N	0230: 230 mm to 2700: 2,700 mm	SV: SSR20XV SW: SSR20XW HV: SHS20V	No symbol: Without QZ Q: With QZ	EH: Belt	0: Without motor (Without coupling. If necessary, please specify.) 1: With motor (THK will purchase and mount the motor you specify.)	N: None B1 B2

When "J" (with bellows) is selected for ⑩ Cover/bellows, specify the stroke with bellows. → p. 42

Please select one of the combinations below.

Table type	③ LM Guide model	④ LM Guide with/without QZ
S table	SV	No symbol: Without QZ
L table	SW / HV	No symbol: Without QZ
L-QZ table	SW / HV	Q: With QZ

Table Type

The block table type is determined by the LM Guide you select. In addition, the stroke range varies depending on the block table type.

- S table Short table (LM Guide model: SSR20XV)
This type has a shorter table to allow for a longer stroke range.
- L table Long table (LM Guide models: SSR20XW, SHS20V)
This type is optimal for high loads or when loads are positioned away from the center of the table.
- L-QZ table Long table with QZ Lubricator (LM Guide models: SSR20XWQZ, SHS20VQZ)
A QZ Lubricator is attached to the LM Guide. (It is longer than an L table. See the dimensional tables on p. 35 to 36.)

Selection Information

Basic Specifications¹

LM Guide	Basic dynamic load rating C (N)	22,300	
	Basic static load rating C ₀ (N)	38,400	
Base	Geometric moment of inertia ²	I_x^3 (mm ⁴)	3.15×10^5
		I_y^4 (mm ⁴)	4.28×10^6
		Mass (kg/m)	6.5
Permissible input rotational speed (min ⁻¹)		3,000	
Starting torque (N-cm)	LM Guide	Without QZ	54.8
		With QZ	91.6
Positioning repeatability (mm)		±0.08	
Permissible input torque (N-m) ⁵		8.1	
Static permissible load ⁶ (N)	LM Guide	Reverse-radial direction	14,300
		Horizontal direction	4,500
		Axial direction	420
Static permissible moment ⁷ (N-m)	LM Guide QZ	Without QZ	M _A : 710, M _B : 430, M _C : 1,180
		With QZ	M _A : 1,070, M _B : 500, M _C : 1,180
Standard grease/Grease nipple used		THK AFB-LF Grease/B-M6F	

¹ These are the values for LM Guide model HV: SHS20V specifications.
² These are the values for the cross-sectional characteristics of the aluminum base.
³ I_x is the geometric moment of inertia about the X axis.
⁴ I_y is the geometric moment of inertia about the Y axis.
⁵ This is the input torque for the shaft end.
⁶ The static permissible load is a value limited by the bolt tightening strength, LM Guide unit, belt, and pulley shaft.
⁷ Static permissible moment is the maximum moment that can be permitted while the product is stationary.
 The reference for M_A and M_C moments is the top surface of the table, while the reference for M_B moments is the center of the table.

Static Permissible Moment

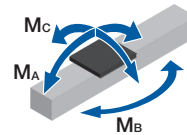

Static Permissible Load

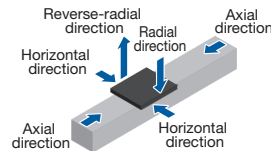

Geometric Moment of Inertia

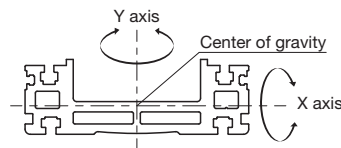

Belt specification reduction gear ⑧	Belt specification reduction ratio ⑨	Cover/bellows ⑩	Sensor ⑪	Cable carrier ⑫
G3	03	C	2	J
No symbol: No reduction gear	No symbol: No reduction gear	N: Without cover C: With cover J: With bellows	N: None 2 3 6 G	N: None A B C D E F G H I J
G1	03: 1/3	With cover → p. 39 With bellows → p. 42	Sensors → p. 40	Cable carrier → p. 40
G2	05: 1/5			
G3	09: 1/9			
G4				
G5				

Motor Selection Information

■ LM Guide

LM Guide model	Moving part mass (kg)	Sliding resistance (N)
GL20N--SV (SSR20XV)	2.1	21
GL20N--SW (SSR20XW)	2.6	21.4
GL20N--SWQ (SSR20XWQZ)	2.8	33.4
GL20N--HV (SHS20V)	3	20.6
GL20N--HVQ (SHS20VQZ)	3.2	36.6

■ Belt Drive

Belt model	Mass ¹ (kg)
025-MA5	0.58

■ Timing Pulley

Timing pulley model	Diameter (PCD) (mm)	Table travel amount per pulley rotation (mm)	Inertial moment (2 total) x 10 ⁻⁴ (kg·m ²)
024-MA5-025	Ø38.2	120	0.447

■ Reduction Gear

Reduction ratio	Motor rated output (W)	Inertial moment x 10 ⁻⁴ (kg·m ²)
1/3	200	0.175
1/3	400	0.175
1/5	100	0.06
1/5	200	0.147
1/5	400	0.370
1/9	100	0.05
1/9	200	0.273

¹ The belt mass is the mass when the base has the maximum length.

Permissible Overhang Length²

Horizontal



200 W		Load mass (kg)	a (mm)	b (mm)	c (mm)
Reduction ratio	1/3	2	1,300	1,300	1,300
		4.5	1,300	1,300	1,300
		9.5	1,300	1,300	1,300
	1/5	8	1,300	1,300	1,300
		16	1,300	1,300	1,300
		32.5	1,300	1,180	1,300

400 W		Load mass (kg)	a (mm)	b (mm)	c (mm)
Reduction ratio	1/3	5	1,300	1,300	1,300
		10	1,300	1,300	1,300
		20	1,300	1,300	1,300
	1/5	12.5	1,300	1,300	1,300
		25	1,300	1,300	1,300
		50	1,300	750	940

² This is the value with the travel life of the LM Guide limited to 10,000 km.

The calculation conditions are as follows.

Stroke: 1,470 mm (LM Guide: SHS20V) / Acceleration/deceleration: 0.3 G / Speed: Rated speed / Overhang direction: Loaded only in a single direction. Dimensions a, b, and c are from the center of the table's upper surface.

Table Travel Amount per Motor Rotation

Pulley pitch circle diameter (mm)	Table travel amount per motor rotation (mm)			
	No reduction gear ³	Reduction ratio		
		1/3	1/5	1/9
Ø38.2	120	40	24	13.3

³ The timing pulley's pitch circle diameter is large, so we recommend using a reduction gear.

Dimensions

With Cover

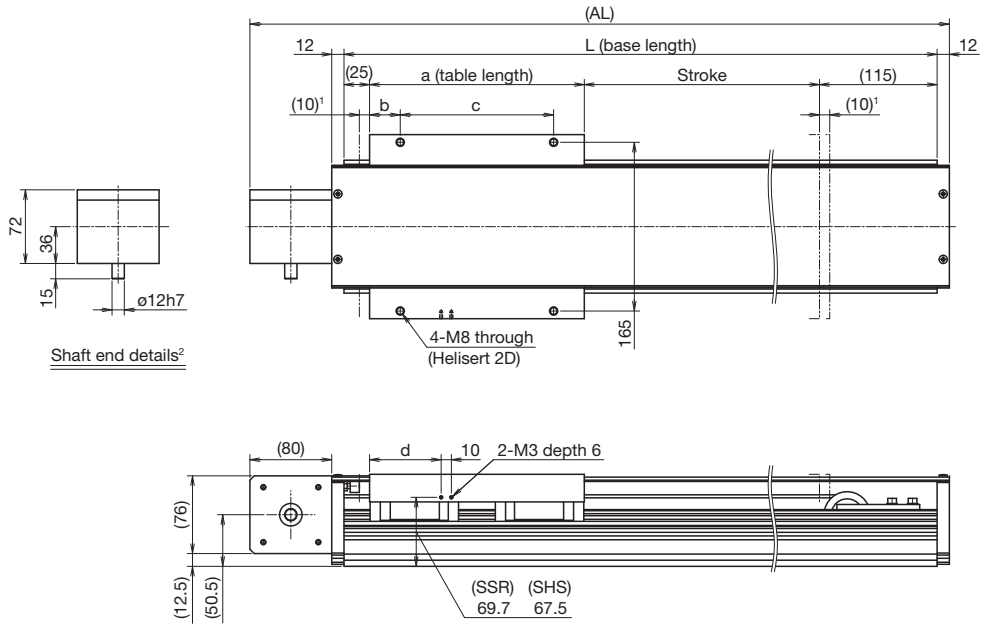

Without Cover

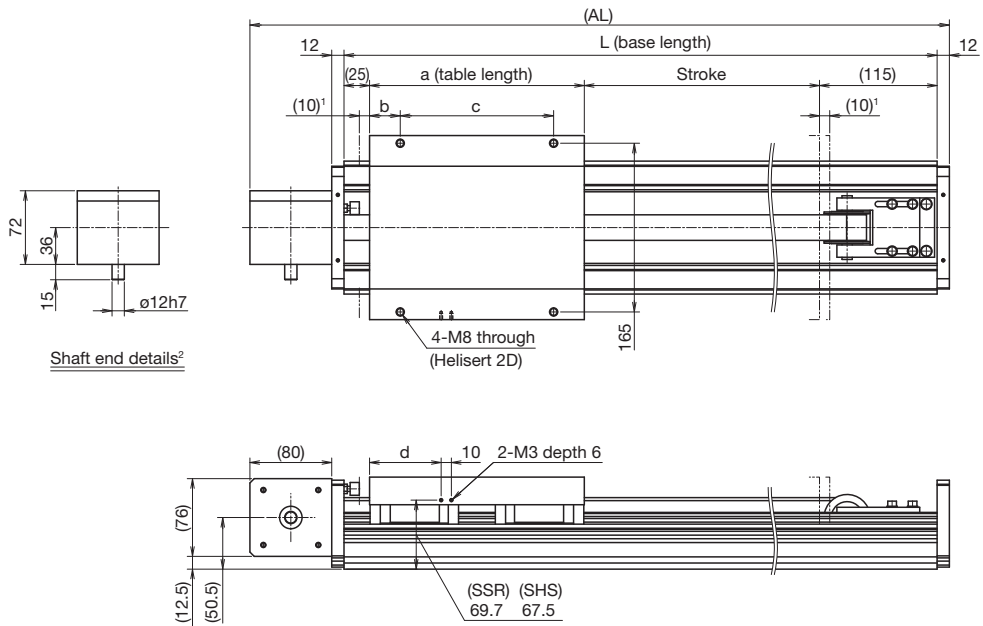

¹ This is the distance between the mechanical stopper and the stroke starting position.

² See p. 36 for details about the bracket mounting surface.

Unit: mm

Table type	a (table length)	b	c	d
S table	160	30	100	45
L table	180	40	100	55
L-QZ table	210	30	150	70

Options

Reduction Gear (Belt Specifications)

These are the reduction gears and motors that can be attached when B1 and B2 are selected for the motor bracket. Specify the motor bracket that matches the motor and reduction gear that will be used.

Reduction Ratio: 1/3

Motor type	Manufacturer	Series	Motor model	Motor rated output (W)	Reduction gear model	Symbol	Compatible reduction gear coupling	
AC servo motor	YASKAWA Electric Corporation	Σ-V	SGMAV-02	200	VRXF-3B-S-200	B1G303	MJC-41-12X12 (MIGHTY CORPORATION, LTD.)	
			SGMAV-04	400	VRXF-3B-S-400	B1G303		
		Σ-7	SGM7A-02	200	VRXF-3B-S-200	B1G303		
			SGM7A-04	400	VRXF-3B-S-400	B1G303		
		Σ-X	SGMXA-02	200	VRXF-3B-S-200	B1G303		
			SGMXA-04	400	VRXF-3B-S-400	B1G303		
	Mitsubishi Electric Corporation	MELSERVO	J4	HG-KR23	200	VRXF-3B-S-200		B1G303
				HG-MR23		VRXF-3B-S-200		B1G303
				HG-KR43	400	VRXF-3B-S-400		B1G303
				HG-MR43		VRXF-3B-S-400		B1G303
			J5	HK-KT23W	200	VRXF-3B-S-200		B1G303
				HK-KT43W	400	VRXF-3B-S-400		B1G303
				HF-KN23	200	VRXF-3B-S-200		B1G303
				HF-KN43	400	VRXF-3B-S-400		B1G303
	TAMAGAWA SEIKI CO., LTD.	TBL-II	TS4607	200	VRXF-3B-S-200	B1G303		
			TS4609	400	VRXF-3B-S-400	B1G303		
		TBL-IV	TSM3202	200	VRXF-3B-S-200	B1G303		
			TSM3204	400	VRXF-3B-S-400	B1G303		
	Panasonic Corporation	MINAS	A5	MSMD02	200	VRXF-3B-S-200		B1G403
				MSMD04	400	VRXF-3B-S-400		B1G503
			A6	MSMF02	200	VRXF-3B-S-200		B1G403
				MSMF04	400	VRXF-3B-S-400		B1G503
	OMRON Corporation	OMNUC G5	R88M-K20030	200	VRXF-3B-S-200	B1G403		
			R88M-K40030	400	VRXF-3B-S-400	B1G503		
		1S	R88M-1M20030	200	VRXF-3B-S-200	B1G403		
			R88M-1M40030	400	VRXF-3B-S-400	B1G503		

Reduction Ratio: 1/5

Motor type	Manufacturer	Series	Motor model	Motor rated output (W)	Reduction gear model	Symbol	Compatible reduction gear coupling		
AC servo motor	YASKAWA Electric Corporation	Σ-V	SGMAV-01	100	VRXF-5B-S-100	B1G105	MJC-33-12X12 (MIGHTY CORPORATION, LTD.)		
			SGMAV-02	200	VRXF-5B-S-200	B1G305	MJC-41-12X12 (MIGHTY CORPORATION, LTD.)		
			SGMAV-04	400	VRXF-5C-S-400	B2G305	MJC-41-12X19 (MIGHTY CORPORATION, LTD.)		
		Σ-7	SGM7A-01	100	VRXF-5B-S-100	B1G105	MJC-33-12X12 (MIGHTY CORPORATION, LTD.)		
			SGM7A-02	200	VRXF-5B-S-200	B1G305	MJC-41-12X12 (MIGHTY CORPORATION, LTD.)		
			SGM7A-04	400	VRXF-5C-S-400	B2G305	MJC-41-12X19 (MIGHTY CORPORATION, LTD.)		
		Σ-X	SGMXA-01	100	VRXF-5B-S-100	B1G105	MJC-33-12X12 (MIGHTY CORPORATION, LTD.)		
			SGMXA-02	200	VRXF-5B-S-200	B1G305	MJC-41-12X12 (MIGHTY CORPORATION, LTD.)		
			SGMXA-04	400	VRXF-5C-S-400	B2G305	MJC-41-12X19 (MIGHTY CORPORATION, LTD.)		
	Mitsubishi Electric Corporation	MELSERVO	J4	HG-KR13	100	VRXF-5B-S-100	B1G105	MJC-33-12X12 (MIGHTY CORPORATION, LTD.)	
				HG-MR13		VRXF-5B-S-100	B1G105	MJC-33-12X12 (MIGHTY CORPORATION, LTD.)	
				HG-KR23	200	VRXF-5B-S-200	B1G305	MJC-41-12X12 (MIGHTY CORPORATION, LTD.)	
				HG-MR23		VRXF-5B-S-200	B1G305	MJC-41-12X12 (MIGHTY CORPORATION, LTD.)	
				HG-KR43	400	VRXF-5C-S-400	B2G305	MJC-41-12X19 (MIGHTY CORPORATION, LTD.)	
				HG-MR43		VRXF-5C-S-400	B2G305	MJC-41-12X19 (MIGHTY CORPORATION, LTD.)	
			J5	HK-KT13W	100	VRXF-5B-S-100	B1G105	MJC-33-12X12 (MIGHTY CORPORATION, LTD.)	
				HK-KT23W	200	VRXF-5B-S-200	B1G305	MJC-41-12X12 (MIGHTY CORPORATION, LTD.)	
				HK-KT43W	400	VRXF-5C-S-400	B2G305	MJC-41-12X19 (MIGHTY CORPORATION, LTD.)	
				HF-KN13	100	VRXF-5B-S-100	B1G105	MJC-33-12X12 (MIGHTY CORPORATION, LTD.)	
			JN	HF-KN23	200	VRXF-5B-S-200	B1G305	MJC-41-12X12 (MIGHTY CORPORATION, LTD.)	
				HF-KN43	400	VRXF-5C-S-400	B2G305	MJC-41-12X19 (MIGHTY CORPORATION, LTD.)	
	TAMAGAWA SEIKI CO., LTD.	TBL-II	TS4603	100	VRXF-5B-S-100	B1G105	MJC-33-12X12 (MIGHTY CORPORATION, LTD.)		
			TS4607	200	VRXF-5B-S-200	B1G305	MJC-41-12X12 (MIGHTY CORPORATION, LTD.)		
			TS4609	400	VRXF-5C-S-400	B2G305	MJC-41-12X19 (MIGHTY CORPORATION, LTD.)		
		TBL-IV	TSM3104	100	VRXF-5B-S-100	B1G105	MJC-33-12X12 (MIGHTY CORPORATION, LTD.)		
			TSM3202	200	VRXF-5B-S-200	B1G305	MJC-41-12X12 (MIGHTY CORPORATION, LTD.)		
			TSM3204	400	VRXF-5C-S-400	B2G305	MJC-41-12X19 (MIGHTY CORPORATION, LTD.)		
	Panasonic Corporation	MINAS	A5	MSMD01	100	VRXF-5B-S-100	B1G205	MJC-33-12X12 (MIGHTY CORPORATION, LTD.)	
				MSMD02	200	VRXF-5B-S-200	B1G405	MJC-41-12X12 (MIGHTY CORPORATION, LTD.)	
				MSMD04	400	VRXF-5C-S-400	B2G505	MJC-41-12X19 (MIGHTY CORPORATION, LTD.)	
			A6	MSMF01	100	VRXF-5B-S-100	B1G205	MJC-33-12X12 (MIGHTY CORPORATION, LTD.)	
				MSMF02	200	VRXF-5B-S-200	B1G405	MJC-41-12X12 (MIGHTY CORPORATION, LTD.)	
				MSMF04	400	VRXF-5C-S-400	B2G505	MJC-41-12X19 (MIGHTY CORPORATION, LTD.)	
	OMRON Corporation	OMNUC G5	R88M-K10030	100	VRXF-5B-S-100	B1G105	MJC-33-12X12 (MIGHTY CORPORATION, LTD.)		
			R88M-K20030	200	VRXF-5B-S-200	B1G405	MJC-41-12X12 (MIGHTY CORPORATION, LTD.)		
			R88M-K40030	400	VRXF-5C-S-400	B2G505	MJC-41-12X19 (MIGHTY CORPORATION, LTD.)		
			R88M-1M10030	100	VRXF-5B-S-100	B1G105	MJC-33-12X12 (MIGHTY CORPORATION, LTD.)		
1S		R88M-1M20030	200	VRXF-5B-S-200	B1G405	MJC-41-12X12 (MIGHTY CORPORATION, LTD.)			
		R88M-1M40030	400	VRXF-5C-S-400	B2G505	MJC-41-12X19 (MIGHTY CORPORATION, LTD.)			

- Notes: 1. The symbols in the table represent the motor bracket, belt specification reduction gear, and belt specification reduction ratio.
 2. In the table, B1 indicates VRXF-□B (NIDEC-SHIMPO CORPORATION), and B2 indicates VRXF-□C (NIDEC-SHIMPO CORPORATION).
 3. When requesting a product with a reduction gear, please inform THK of the motor model that will be attached.
 4. The table shows only a portion of the model numbers for motors. For details regarding model numbers, please see the catalog for each respective motor manufacturer.
 5. Contact THK if you will be using a motor with a reduction gear.
 6. If the reduction gear's output torque will exceed the permissible input torque (p. 33) due to the maximum torque of the installed motor and the reduction ratio, please consider a safety measure to limit the torque.

Reduction Ratio: 1/9

Motor type	Manufacturer	Series	Motor model	Motor rated output (W)	Reduction gear model	Symbol	Compatible reduction gear coupling	
AC servo motor	YASKAWA Electric Corporation	Σ-V	SGMAV-01	100	VRXF-9B-S-100	B1G109	MJC-41-12X12 (MIGHTY CORPORATION, LTD.)	
			SGMAV-02	200	VRXF-9C-S-200	B2G309	MJC-41-12X19 (MIGHTY CORPORATION, LTD.)	
		Σ-7	SGM7A-01	100	VRXF-9B-S-100	B1G109	MJC-41-12X12 (MIGHTY CORPORATION, LTD.)	
			SGM7A-02	200	VRXF-9C-S-200	B2G309	MJC-41-12X19 (MIGHTY CORPORATION, LTD.)	
		Σ-X	SGMXA-01	100	VRXF-9B-S-100	B1G109	MJC-41-12X12 (MIGHTY CORPORATION, LTD.)	
			SGMXA-02	200	VRXF-9C-S-200	B2G309	MJC-41-12X19 (MIGHTY CORPORATION, LTD.)	
	Mitsubishi Electric Corporation	MELSERVO	J4	HG-KR13	100	VRXF-9B-S-100	B1G109	MJC-41-12X12 (MIGHTY CORPORATION, LTD.)
				HG-MR13		VRXF-9B-S-100	B1G109	MJC-41-12X12 (MIGHTY CORPORATION, LTD.)
				HG-KR23	200	VRXF-9C-S-200	B2G309	MJC-41-12X19 (MIGHTY CORPORATION, LTD.)
			HG-MR23	VRXF-9C-S-200		B2G309	MJC-41-12X19 (MIGHTY CORPORATION, LTD.)	
			J5	HK-KT13W	100	VRXF-9B-S-100	B1G109	MJC-41-12X12 (MIGHTY CORPORATION, LTD.)
				HK-KT23W	200	VRXF-9C-S-200	B2G309	MJC-41-12X19 (MIGHTY CORPORATION, LTD.)
		JN		HF-KN13	100	VRXF-9B-S-100	B1G109	MJC-41-12X12 (MIGHTY CORPORATION, LTD.)
			HF-KN23	200	VRXF-9C-S-200	B2G309	MJC-41-12X19 (MIGHTY CORPORATION, LTD.)	
		TAMAGAWA SEIKI CO., LTD.	TBL-II	TS4603	100	VRXF-9B-S-100	B1G109	MJC-41-12X12 (MIGHTY CORPORATION, LTD.)
	TS4607			200	VRXF-9C-S-200	B2G309	MJC-41-12X19 (MIGHTY CORPORATION, LTD.)	
	TBL-III		TSM3104	100	VRXF-9B-S-100	B1G109	MJC-41-12X12 (MIGHTY CORPORATION, LTD.)	
			TSM3202	200	VRXF-9C-S-200	B2G309	MJC-41-12X19 (MIGHTY CORPORATION, LTD.)	
	Panasonic Corporation	MINAS	A5	MSMD01	100	VRXF-9B-S-100	B1G209	MJC-41-12X12 (MIGHTY CORPORATION, LTD.)
				MSMD02	200	VRXF-9C-S-200	B2G409	MJC-41-12X19 (MIGHTY CORPORATION, LTD.)
			A6	MSMF01	100	VRXF-9B-S-100	B1G209	MJC-41-12X12 (MIGHTY CORPORATION, LTD.)
				MSMF02	200	VRXF-9C-S-200	B2G409	MJC-41-12X19 (MIGHTY CORPORATION, LTD.)
	OMRON Corporation	OMNUC G5	R88M-K10030	100	VRXF-9B-S-100	B1G109	MJC-41-12X12 (MIGHTY CORPORATION, LTD.)	
			R88M-K20030	200	VRXF-9C-S-200	B2G409	MJC-41-12X19 (MIGHTY CORPORATION, LTD.)	
		1S	R88M-1M10030	100	VRXF-9B-S-100	B1G109	MJC-41-12X12 (MIGHTY CORPORATION, LTD.)	
			R88M-1M20030	200	VRXF-9C-S-200	B2G409	MJC-41-12X19 (MIGHTY CORPORATION, LTD.)	

Notes: 1. The symbols in the table represent the motor bracket, belt specification reduction gear, and belt specification reduction ratio.

2. In the table, B1 indicates VRXF-□B (NIDEC-SHIMPO CORPORATION), and B2 indicates VRXF-□C (NIDEC-SHIMPO CORPORATION).

3. When requesting a product with a reduction gear, please inform THK of the motor model that will be attached.

4. The table shows only a portion of the model numbers for motors. For details regarding model numbers, please see the catalog for each respective motor manufacturer.

5. Contact THK if you will be using a motor with a reduction gear.

6. If the reduction gear's output torque will exceed the permissible input torque (p. 33) due to the maximum torque of the installed motor and the reduction ratio, please consider a safety measure to limit the torque.

Options

QZ Lubricator

LM Guide

The QZ Lubricator feeds the right amount of lubricant to the LM rail raceway. This allows an oil film to continuously form between the balls and the raceway, and it significantly extends the lubrication maintenance intervals.

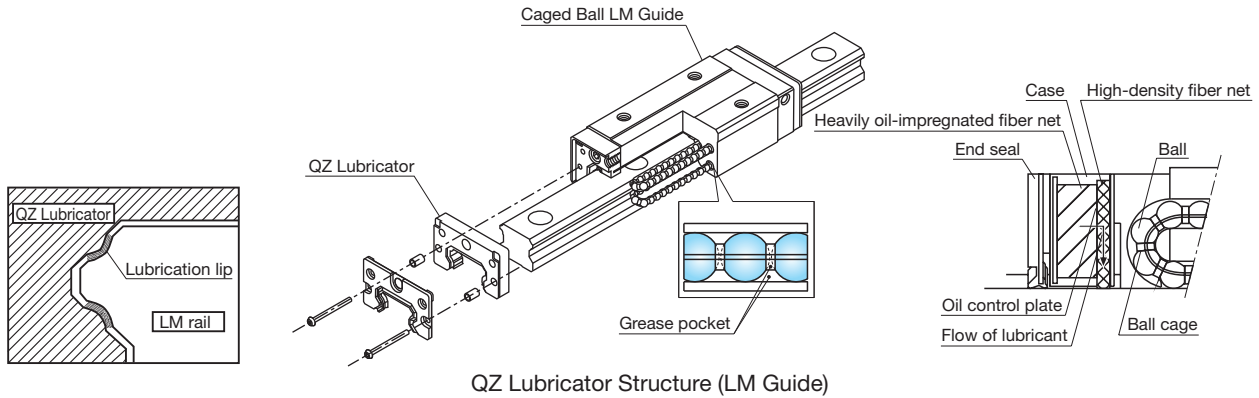

Cover

A simple cover is provided to protect the interior.

The cover is shared between the GL15N and GL20N.

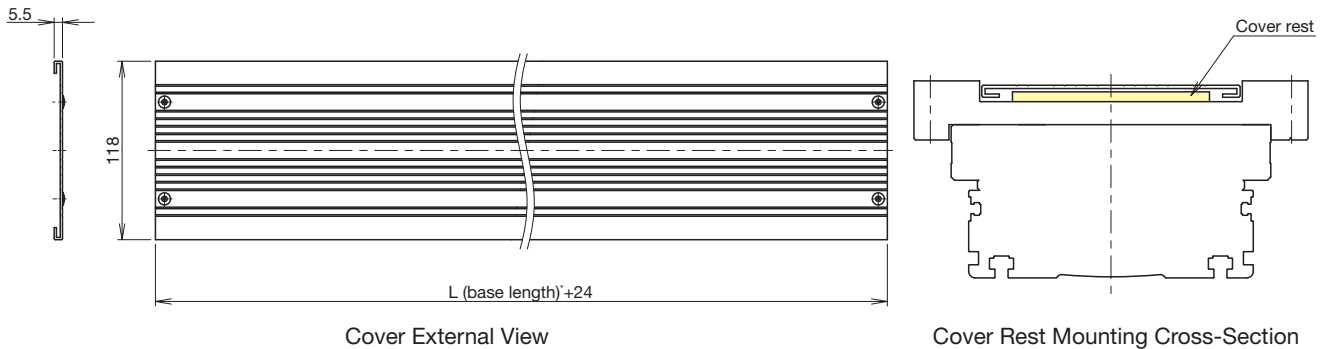

* For base length, see the dimensional table. → p. 35 to 36

Notes: 1. If the base is long, the cover will experience more deflection.

Therefore, to prevent interference with the table, a cover rest is installed on the table as standard for models with base lengths of 1,000 mm or more. (See the figure above.)

However, please note that when the base is long, the deflection of the cover will increase due to its weight, which may cause the cover to come in contact with other components (such as the rail or belt).

2. Take care when using this product in anything other than a horizontal orientation. The deflection of the cover may cause it to come in contact with parts mounted on the table.

Sensors

Optional photo sensors and proximity sensors are available.

Sensors can be mounted using the T-slot on the side of the base.

Symbol	Description	Model	Accessories
N	None	-	-
2	Photo sensors ¹ (x3)	EE-SX671 (OMRON Corporation)	Mounting screws/nuts, sensor dog (x1 or x2), mounting plates (x3)
6	Photo sensors ¹ (x3)	EE-SX674 (OMRON Corporation)	Mounting screws/nuts, sensor dog (x1 or x2), mounting plates (x3)
3	Proximity sensors: N.O. contact ² (x3)	TL-W3MC1 (OMRON Corporation)	Mounting screws/nuts, sensor dog (x1 or x2)
G	Proximity sensors: N.O. contact ² (x1) N.C. contact ³ (x2)	TL-W3MC1 (OMRON Corporation) TL-W3MC2 (OMRON Corporation)	Mounting screws/nuts, sensor dog (x1 or x2)

¹ The photo sensors can be switched between ON when lit and ON when unlit.

Notes: 1. All sensor output is NPN.

² N.O. contact: Normally open contact

2. Sensors and accessories will be mounted to the unit before shipping.

³ N.C. contact: Normally closed contact

Photo Sensor Mounting Dimensions

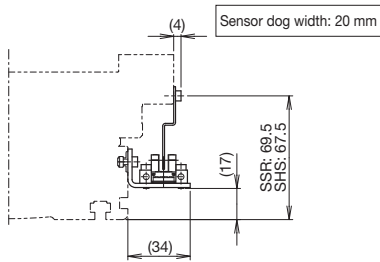

Symbol	Model	Manufacturer
2	EE-SX671	OMRON Corporation

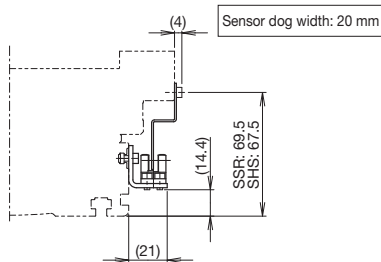

Symbol	Model	Manufacturer
6	EE-SX674	OMRON Corporation

Proximity Sensor Mounting Dimensions

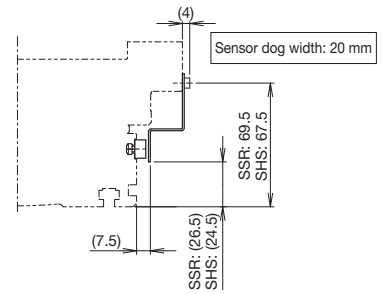

Symbol	Model	Manufacturer
3	TL-W3MC1	OMRON Corporation
G	TL-W3MC1 TL-W3MC2	

Cable Carrier

A variety of cable carriers can be mounted using the T-slot on the side of the base.

When selecting a cable carrier, specify the corresponding symbol from the table below.

Symbol	Cable carrier model	Manufacturer
A	TKP0180W40R28	TSUBAKIMOTO CHAIN CO.
B	TKP0180W40R37	
C	TKP0180W40R50	
D	TKP35H22-30W25R37	
E	TKP35H22-30W25R50	

Symbol	Cable carrier model	Manufacturer
F	TKP35H22-30W25R75	TSUBAKIMOTO CHAIN CO.
G	TKP35H22-30W50R37	
H	TKP35H22-30W50R50	
I	TKP35H22-30W50R75	
J	KSH-24L-42	THK CO., LTD.

Note 3: For the selection of the cable carrier, please see the corresponding cable carrier catalog.

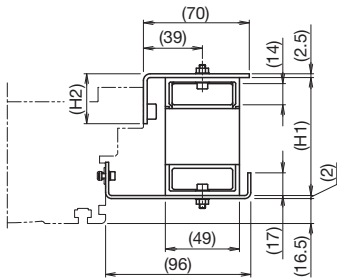

Symbol	Cable carrier model	H1	H2
A	TKP0180W40R28	78	33
B	TKP0180W40R37	96	51
C	TKP0180W40R50	122	77

Unit: mm

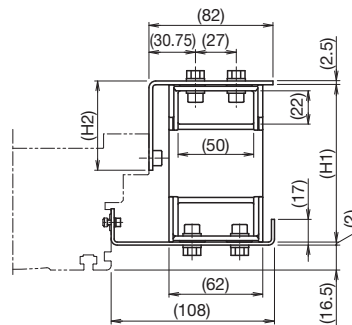

Symbol	Cable carrier model	H1	H2
G	TKP35H22-30W50R37	104	59
H	TKP35H22-30W50R50	130	85
I	TKP35H22-30W50R75	180	135

Unit: mm

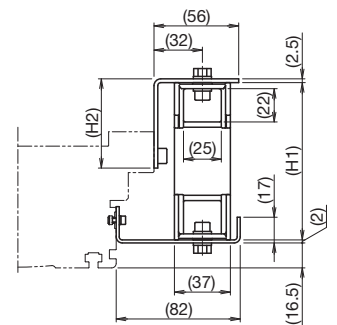

Symbol	Cable carrier model	H1	H2
D	TKP35H22-30W25R37	104	59
E	TKP35H22-30W25R50	130	85
F	TKP35H22-30W25R75	180	135

Unit: mm

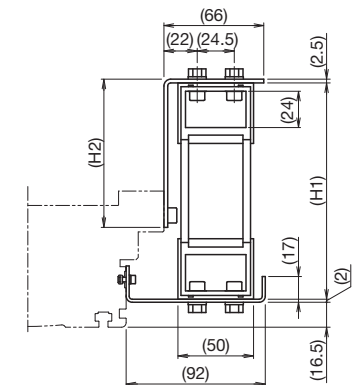

Symbol	Cable carrier model	H1	H2
J	KSH-24L-42	143	98

Unit: mm

Options

Bellows

In addition to a cover, bellows are also available as a contamination protection option.

Ball Screw Type

Direct Motor Coupling/Motor Wrap

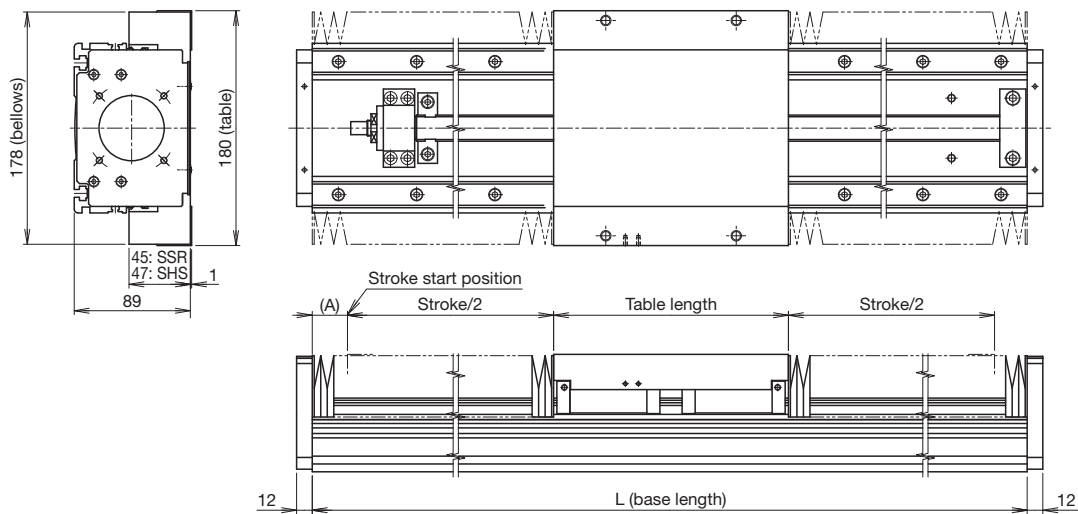

Unit: mm

Table type	Table length
S table	160
L table	180
L (QZ) table	180
L-QZ table	210

Unit: mm

Stroke*	S table	220 (237)	330 (352)	440 (464)	550 (569)	760 (779)	920 (939)	1,070 (1,094)	1,230 (1,254)	1,390 (1,409)
	L table	210 (227)	320 (339)	420 (444)	530 (549)	740 (759)	900 (919)	1,050 (1,074)	1,210 (1,234)	1,370 (1,389)
	L (QZ) table	210 (227)	320 (339)	420 (444)	530 (549)	740 (759)	900 (919)	1,050 (1,074)	1,210 (1,234)	1,370 (1,389)
	L-QZ table	180 (198)	290 (309)	390 (414)	500 (519)	710 (729)	870 (889)	1,020 (1,044)	1,180 (1,204)	1,340 (1,359)
L (Base length)		460	580	700	820	1,060	1,240	1,420	1,600	1,780
A: Stroke start	S table	50	50	50	55	70	80	90	100	115
	L table	40	40	50	55	70	80	90	100	115
	L (QZ) table	45	45	50	55	70	80	90	100	115
	L-QZ table	35	40	50	55	70	80	90	100	115

* Values in parentheses are the maximum stroke.

Notes: 1. For the model number coding, use the stroke when bellows are attached.

2. When using bellows, the stroke will be shorter. See the specifications and dimensional diagrams for the stroke when not using bellows. → p. 27 to 28

Belt-Driven Type

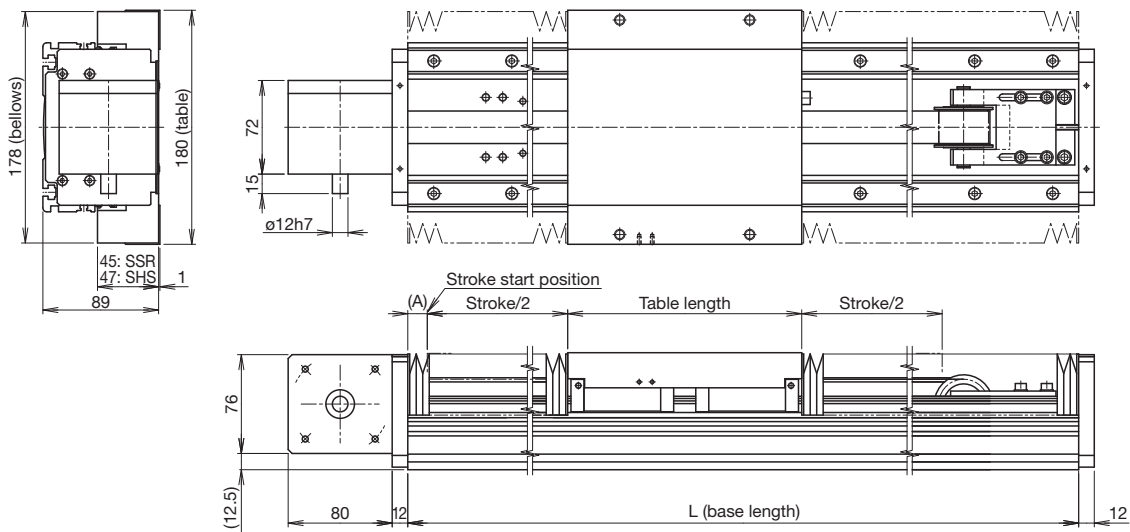

Unit: mm

Table type	Table length
S table	160
L table	180
L-QZ table	210

Unit: mm

Stroke*	S table	250 (267)	350 (374)	460 (482)	680 (697)	830 (849)	970 (989)	1,120 (1,134)	1,250 (1,274)	1,400 (1,419)	1,590 (1,609)	1,680 (1,704)	1,820 (1,844)	2,220 (2,239)
	L table	230 (247)	330 (354)	440 (462)	660 (677)	810 (829)	950 (969)	1,090 (1,114)	1,230 (1,254)	1,380 (1,399)	1,570 (1,589)	1,660 (1,684)	1,800 (1,824)	2,200 (2,219)
	L-QZ table	200 (217)	300 (324)	410 (432)	630 (647)	780 (799)	920 (939)	1,060 (1,084)	1,200 (1,224)	1,350 (1,369)	1,540 (1,559)	1,630 (1,654)	1,770 (1,794)	2,170 (2,189)
L (Base length)		580	700	820	1,060	1,240	1,420	1,600	1,780	1,960	2,200	2,320	2,500	3,000
A: Stroke start		60	70	80	100	125	145	160	180	200	225	240	260	310

* Values in parentheses are the maximum stroke.

Notes: 1. For the model number coding, use the stroke when bellows are attached.

2. When using bellows, the stroke will be shorter. See the specifications and dimensional diagrams for the stroke when not using bellows. → p. 35 to 36

Load Rating

Ball Screw Type Load Rating

Model		GL15N					GL20N				
Drive system		Ball screw					Ball screw				
LM Guide	Basic dynamic load rating C (N)	14,200					22,300				
	Basic static load rating C ₀ (N)	24,200					38,400				
Ball screw lead (mm)		5	10	16	20	30	5	10	20	40	
Ball screw	Basic dynamic load rating C _a (N)	5,400	9,800	5,800	5,500	4,300	6,000	9,800	7,700	5,400	
	Basic static load rating C _{0a} (N)	13,300	25,200	12,900	14,200	9,300	16,500	25,200	22,300	13,600	
Bearing (fixed side)	Axial direction	Basic dynamic load rating C _a (N)	6,100					6,650			
		Static permissible load P _{0a} (N)	2,100					2,200			

Note 1: These are the values for when "HV: SHS-V" is chosen for the LM Guide model.

Belt-Driven Type Load Rating

Model		GL15N		GL20N	
Drive system		Belt		Belt	
LM Guide	Basic dynamic load rating C (N)	14,200		22,300	
	Basic static load rating C ₀ (N)	24,200		38,400	

Note 2: These are the values for when "HV: SHS-V" is chosen for the LM Guide model.

Static Permissible Load and Static Permissible Moment

Ball Screw Type Static Permissible Load and Static Permissible Moment

Model		GL15N				GL20N		
Drive system		Ball screw				Ball screw		
LM Guide		Model SSR15XV	Model SSR15XW	Model SSR15XWQZ	Model SSR20XV	Model SSR20XW	Model SSR20XWQZ	
			Model SHS15V	Model SHS15VQZ		Model SHS20V	Model SHS20VQZ	
Positioning repeatability ¹ (mm)		±0.02				±0.02		
Static permissible load ² (N)	Reverse-radial direction	9,600				14,300		
	Horizontal direction	2,900				4,500		
	Axial direction	2,100				2,200		
Static permissible moment ³ (N·m)	M _A	430		570		710		1,070
	M _B	240		260		430		500
	M _C	610	670		1,020	1,180		

¹ Positioning repeatability is the guaranteed accuracy with an ambient temperature of 20°C.

² The static permissible load is determined by the bolt tightening strength, the static load rating of the LM Guide and the ball screw, and the static permissible load of the bearing.

The strength of the actuator's mounting area is not included, so take this into consideration to achieve an adequate level of safety.

³ Static permissible moment is the maximum moment that can be permitted while the product is stationary.

The reference for M_A and M_C moments is the top surface of the table, while the reference for M_B moments is the center of the table.

Belt-Driven Type Static Permissible Load and Static Permissible Moment

Model		GL15N				GL20N		
Drive system		Belt				Belt		
LM Guide		Model SSR15XV	Model SSR15XW	Model SSR15XWQZ	Model SSR20XV	Model SSR20XW	Model SSR20XWQZ	
			Model SHS15V	Model SHS15VQZ		Model SHS20V	Model SHS20VQZ	
Positioning repeatability ⁴ (mm)		±0.08				±0.08		
Static permissible load ⁵ (N)	Reverse-radial direction	9,600				14,300		
	Horizontal direction	2,900				4,500		
	Axial direction	270				420		
Static permissible moment ⁶ (N·m)	M _A	430		570		710		1,070
	M _B	240		260		430		500
	M _C	610	670		1,020	1,180		

⁴ Positioning repeatability is the guaranteed accuracy with an ambient temperature of 20°C.

⁵ The static permissible load is a value limited by the bolt tightening strength, LM Guide unit, belt, and pulley shaft.

The strength of the actuator's mounting area is not included, so take this into consideration to achieve an adequate level of safety.

⁶ Static permissible moment is the maximum moment that can be permitted while the product is stationary.

The reference for M_A and M_C moments is the top surface of the table, while the reference for M_B moments is the center of the table.

Service Life and Static Safety Factor

The GL-N is made up of LM Guide units, a ball screw (or belt), and support units.

Refer to the THK linear motion system general catalog for the service life and static safety factor of each component (LM Guide, ball screw, and support unit).

Furthermore, the nominal life of the LM Guide can be calculated using THK Online Services (thk.com) or the technical calculation software included in the DVD catalog. When calculating the nominal life, please reference the data in the below table. For information about the ball screw, please contact THK.

Note: Service life calculations are theoretical calculations. The actual service life may vary depending on usage conditions such as environment, lubrication status, mounting surface accuracy, and rigidity.

Thrust Position and Center of Gravity

Actuator model	Drive system	LM Guide symbol	LM Guide with/without QZ	LM Guide model	Thrust position		Rail span W (mm)	Block span L1 (mm)	Mass m1 (kg)	Moving part Center of gravity			Slider height H (mm)	
					B1 (mm)	B2 (mm)				G1 (mm)	G2 (mm)	G3 (mm)		
GL15N	Ball screw	SV	Without	SSR15XV	45	-5.4	90	82	1.7	45	41	30	43	
			With	SSR15XW		74		2.2	37		30			
		SW	Without	SSR15XV		-5.4		94	2.4		47	30		43
			With	SSR15XW		-5.4		74	2.2		37	30		43
	Belt	SV	Without	SSR15XV	45	-26	90	82	1.2	45	41	30	43	
			With	SSR15XW		74		1.7	37		30	43		
		SW	Without	SSR15XV		-26		94	1.8		47	30		43
			With	SSR15XW		-26		74	1.7		37	30		43
GL20N	Ball screw	SV	Without	SSR20XV	51	-2	102	108	2.7	51	54	34.6	48	
			With	SSR20XW		108		3.2	54		34.6	48		
		SW	Without	SSR20XV		-2		110	3.4		55	34.6		48
			With	SSR20XW		-2		96	3.6		48	34.6		50
	Belt	SV	Without	SSR20XV	51	-27	102	108	2.1	51	54	34.6	48	
			With	SSR20XW		108		2.6	54		34.6	48		
		SW	Without	SSR20XV		-27		110	2.8		55	34.6		48
			With	SSR20XW		-27		96	3		48	36.6		50
HV	Without	SHS20V	-29	110	3.2	55	36.6	50						
	With	SHS20V	-29											

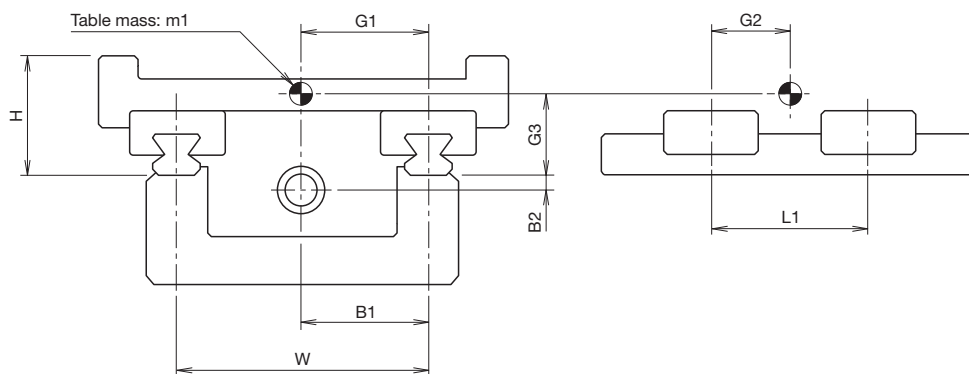

Precautions on Use

How to Use This Product

- This product must not be used for devices or systems that are utilized under situations that may affect human life.
- Be sure to contact THK in advance if you are considering using this product for special applications, such as with devices or systems relating to passenger vehicles, medicine, aerospace, nuclear power, or electric power.

Products with Rotary Motor Drives

Handling

- Please contact THK when using the product in special environments such as locations exposed to constant vibrations, clean rooms, vacuums, and low/high temperatures.
- Tilting a table or outer rail may cause it to fall by its own weight.

Safety Precautions

- Carefully read JIS B8433 "Manipulating Industrial Robots - Safety" and the Japanese Ministry of Health, Labour and Welfare's "Ordinance on Industrial Safety and Health" before working with the product, and follow the guidance within.
- Carefully read the user manual, gain a sufficient understanding of its contents, and be sure to follow the safety precautions.
- When installing, adjusting, inspecting, or performing maintenance on the main actuator unit and connected peripherals, be sure to remove all power plugs from their outlets, and prepare a lock or safety plug to prevent anyone else from turning on the power. Additionally, place a sign in a visible location to notify others that work is being performed.
- Do not touch any moving parts of the actuator while it is energized. In addition, do not enter the operating range of this product while it is in operation or in an operable state.
- If performing a task involving multiple people, confirm how to perform the work, what signals will be used, and how to handle problems before beginning, and assign another person to monitor the work.
- Do not carelessly disassemble this product. Otherwise, it may cause foreign material ingress or decrease the accuracy.
- Take care not to drop or strike this product. Otherwise, it may cause injury or damage the unit. Even if there is no outward indication of damage, a sudden impact could prevent the unit from functioning properly.
- Using this product in excess of the permissible rotational speed may damage the components or cause an accident. Be sure to use the product within the specified rotational speed designated by THK.
- Prevent foreign materials such as cutting chips from entering the product. Otherwise, it may damage the ball circulation components or result in a loss of functionality.
- If using the product in an environment where coolant may get inside, contact THK.
- Install shock absorbers or another impact-absorbing mechanism if there is a risk that the slider may strike the stoppers mounted on both ends of the range of motion. The stoppers are not intended to absorb the impact from sliders. Impacts to the stoppers during operation may lead to damage or accidents.
- Using this product in excess of the torque limit may damage the components or cause an accident.
- Do not set the torque control parameter higher than the torque limit.
- The motor wrap type does not have a safety device for if the timing belt breaks. For your safety, please install a safety device next to the equipment.
- Some models of this product are heavy, with the main unit of this product weighing in excess of 20 kg. Use appropriate transportation equipment and take safety precautions to avoid injury or damage when transporting or installing the product.
- In applications where this product will be moved or transferred, the conditions of use may cause inertia from the motor's mass to result in damage to the motor attachment (Housing A) or other parts. Please contact THK before using in this manner.

Service Environment

- Indoors, with an ambient temperature between 0°C and 40°C and ambient humidity at 80% RH or less (no freezing or condensation)
- A location with no corrosive or flammable gas
- A location where vibrations or impacts are not transmitted to the main unit
- A location where electrically conductive particles such as steel dust, dust, oil mist, cutting oil, water content, salt content, or organic solvents will not be present in the air
- A location not exposed to direct sunlight or radiant heat
- A location where no strong electric fields or powerful magnetic fields are generated
- A location where inspections and cleanings can easily be performed
- If this product will be used in special environments, such as one with constant vibrations, in a vacuum, or at very low or high temperatures, contact THK.

Actuator Mounting Surface

- Prepare a flat surface that has been machined or possesses an equivalent level of accuracy. Some products specify a required level of flatness.
- Be sure to mount the product on a sufficiently rigid base.

Lubrication

- The actuator must be lubricated in order for it to demonstrate its full performance. Insufficient lubrication may increase wear on the rolling elements and lead to premature damage.
- Do not mix lubricants with different properties. Please be aware that the applied lubricant will differ depending on the product.
- Contact THK if a special lubricant will be used.
- As a general guideline, the greasing interval should be every 100 km. However, this will vary depending on the operating conditions, so we recommend determining the greasing interval based on the initial inspection.
- Contact THK if the product will be used in a special environment such as a location with constant vibrations, a vacuum, high/low temperatures, or a clean room, as it may not be possible to use the regular lubricant.
- Contact THK if oil lubricant will be used.
- Thoroughly wipe off anti-rust oil and feed lubricant before using the product.

Storage

- When storing the actuator, enclose it in a package designated by THK and store it in a horizontal orientation while avoiding high temperatures, low temperatures, and high humidity.
- Avoid storing control devices in an environment with high/low temperatures or high humidity.

Disposal

- The product should be treated as industrial waste and disposed of appropriately.

Other Recommended Products



Universal Series

TH

- Lightweight and highly rigid thanks to a hollow aluminum base.
- Optimal for transferring heavy objects and moving at high speeds over long strokes.
- Many options are available, including covers, bellows, sensors, and cable carriers.



LM Guide Actuator

KR

- Modularized structure reduces number of components and both design and assembly time.
- Can be used in various orientations, including horizontal, wall-mounted, vertical, and hanging.
- Extensive lineup of nine sizes.



Press Series

For Servo Presses

PC

- Enables maximum instantaneous thrust of 250 kN.
- Electric actuator with built-in DSP.
- Choose from an extensive range of control devices.

Universal Series Electric Actuator GL-N

- **LM Guide and Caged Ball**  are registered trademarks of **THK CO., LTD.**
- The actual products may differ from the illustrations and photographs in this catalog.
- Outward appearances and specifications are subject to change without notice for the purpose of improvement. Please consult with THK before using.
- Although great care has been taken in the production of this catalog, THK will not take any responsibility for damages resulting from typographical errors or omissions.
- For exports of our products and technologies and sales for export, our basic policy is to comply with the Foreign Exchange and Foreign Trade Act and other laws and regulations. Please consult us in advance if you want to export our products by the piece.

All rights reserved.

THK CO., LTD.

Global Headquarters 2-12-10 Shibaura, Minato-ku, Tokyo 108-8506 Japan

International Sales Department Phone: +81-3-5730-3860

www.thk.com