

Cam Follower with Tapped Lubrication Hole Model CFT

Optional specifications		Symbol
Roller guide	With cage	No Symbol
	Full rollers	V
Material	Carbon steel	No Symbol
	Stainless steel	M
Seal	Without seal	No Symbol
	With seal	UU
Outer ring shape	Cylindrical outer ring	No Symbol
	Spherical outer ring	R

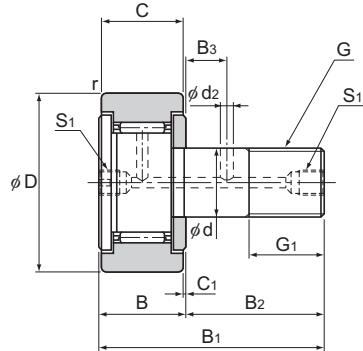

Stud diameter	Model No.	Main dimensions												
		Outer diameter	Outer ring width	Threaded			Overall length						Shoulder height	
d		D	C	G	G ₁	B	B ₁	B ₂	B ₃	C ₁	S ₁	d ₂	r _{min}	f (Min.)
6	CFT 6	16	11	M6×1	8	12	28	16	—	0.6	M6×0.75'	—	0.3	11
8	CFT 8	19	11	M8×1.25	10	12	32	20	—	0.6	M6×0.75'	—	0.3	13
10	CFT 10	22	12	M10×1.25	12	13	36	23	—	0.6	M6×0.75'	—	0.3	15
10	CFT 10-1	26	12	M10×1.25	12	13	36	23	—	0.6	M6×0.75'	—	0.3	15
12	CFT 12	30	14	M12×1.5	13	15	40	25	6	0.6	M6×0.75'	3	0.6	20
12	CFT 12-1	32	14	M12×1.5	13	15	40	25	6	0.6	M6×0.75'	3	0.6	20
16	CFT 16	35	18	M16×1.5	17	19.5	52	32.5	8	0.8	Rc1/8 (PT1/8)	3	0.6	24
18	CFT 18	40	20	M18×1.5	19	21.5	58	36.5	8	0.8		3	1	26
20	CFT 20	52	24	M20×1.5	21	25.5	66	40.5	9	0.8		4	1	36
20	CFT 20-1	47	24	M20×1.5	21	25.5	66	40.5	9	0.8		4	1	36
24	CFT 24	62	29	M24×1.5	25	30.5	80	49.5	11	0.8		4	1	40
24	CFT 24-1	72	29	M24×1.5	25	30.5	80	49.5	11	0.8		4	1	40
30	CFT 30	80	35	M30×1.5	32	37	100	63	15	1		4	1	46
30	CFT 30-1	85	35	M30×1.5	32	37	100	63	15	1		4	1	46
30	CFT 30-2	90	35	M30×1.5	32	37	100	63	15	1		4	1	46

Note: For information on accuracy standards, please refer to **A19-14**.

Model number coding

CFT30-1 V M UU R -N

Model No.

No symbol: With cage

V : Full-roller Type

No symbol: Carbon steel

M : Stainless steel

No symbol: Without seal

UU : With seal

No Symbol: No grease nipple

N : Dedicated grease nipple included (See **A19-39**)

No Symbol: Cylindrical outer ring

R : Spherical outer ring

Note: For accessories, please refer to **A19-38**.

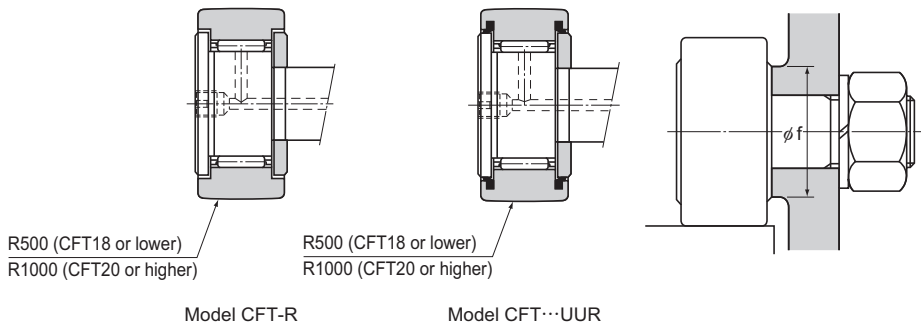

Unit: mm

	Basic load rating				Maximum permissible load F_0 kN	Track load capacity		Rotational speed limit ²		Mass	
	With cage		Full rollers			Cylindrical outer ring kN	Spherical outer ring kN	With cage min^{-1}	Full rollers min^{-1}	With cage g	Full rollers g
	C kN	C_0 kN	C kN	C_0 kN							
	3.59	3.58	6.94	8.5	2.11	3.43	1.08	25000	11000	18.5	19
	4.17	4.65	8.13	11.2	4.73	4.02	1.37	20000	8700	28.5	29
	5.33	6.78	9.42	14.3	5.81	4.7	1.67	17000	7200	45	46
	5.33	6.78	9.42	14.3	5.81	5.49	2.06	17000	7200	60	61
	7.87	9.79	13.4	19.8	9.37	7.06	2.45	14000	5800	105	107
	7.87	9.79	13.4	19.8	9.37	7.45	2.74	14000	5800	115	117
	12	18.3	20.6	37.6	17.3	11.2	3.14	10000	4500	205	207
	14.7	25.2	25.2	51.3	26.1	14.4	3.72	8500	3800	295	300
	20.7	34.8	33.2	64.8	32.1	23.2	8.23	7000	3400	525	530
	20.7	34.8	33.2	64.8	32.1	21	7.15	7000	3400	450	455
	30.6	53.2	46.7	92.9	49.5	34.2	10.5	6500	2900	915	925
	30.6	53.2	46.7	92.9	49.5	39.8	12.9	6500	2900	1150	1160
	45.4	87.6	67.6	145	73.7	52.6	14.9	5000	2300	1880	1890
	45.4	87.6	67.6	145	73.7	56	16.1	5000	2300	1950	1960
	45.4	87.6	67.6	145	73.7	59.3	17.3	5000	2300	2000	2010

¹ These models have a lubrication hole only on the head.

² The rotation speed limit value in the table applies to models that have no seal and use grease lubrication. With those models using oil lubrication, up to 130% of this value is permitted. With those attached with seals, up to 70% of this value is permitted.