

Model RE (Two-Piece Inner Ring Type)

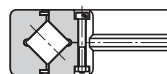

Model RE

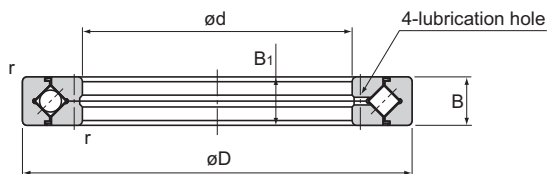
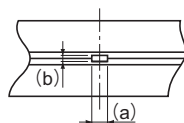
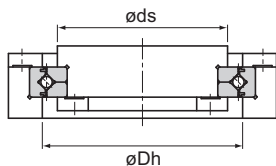

Detail view of the lubrication hole

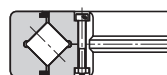

Model RE...UU

Unit: mm

Shaft diameter	Model No.	Main dimensions							Shoulder height		Basic load rating (radial)		Mass
		Inner diameter	Outer diameter	Roller pitch circle diameter	Width	Lubrication hole		r_{min}	ds (max)	Dh (min)	C	C_0	
						B	B_1						
20	RE 2008	20	36	29	8	2	0.8	0.5	24.5	32.5	3.23	3.1	0.04
25	RE 2508	25	41	34	8	2	0.8	0.5	29.5	37.5	3.63	3.83	0.05
30	RE 3010	30	55	43.5	10	2.5	1	0.6	37.5	48.5	7.35	8.36	0.12
35	RE 3510	35	60	48.5	10	2.5	1	0.6	42.5	53.5	7.64	9.12	0.13
40	RE 4010	40	65	53.5	10	2.5	1	0.6	47.5	58.5	8.33	10.6	0.16
45	RE 4510	45	70	58.5	10	2.5	1	0.6	52.5	63.5	8.62	11.3	0.17
50	RE 5013	50	80	66	13	2.5	1.6	0.6	57.5	73	16.7	20.9	0.27
60	RE 6013	60	90	76	13	2.5	1.6	0.6	68	83	18	24.3	0.3
70	RE 7013	70	100	86	13	2.5	1.6	0.6	78	93	19.4	27.7	0.35
80	RE 8016	80	120	101.4	16	3	1.6	0.6	91	111	30.1	42.1	0.7
90	RE 9016	90	130	112	16	3	1.6	1	100	122	31.4	45.3	0.75
100	RE 10016	100	140	121.1	16	3	1.6	1	109	131	31.7	48.6	0.83
	RE 10020		150	127	20	3.5	1.6	1	115	137	33.1	50.9	1.45
110	RE 11012	110	135	123.3	12	2.5	1	0.6	117	128	12.5	24.1	0.4
	RE 11015		145	129	15	3	1.6	0.6	122	136	23.7	41.5	0.75
	RE 11020		160	137	20	3.5	1.6	1	125	147	34	54	1.56
120	RE 12016	120	150	136	16	3	1.6	0.6	127	143	24.2	43.2	0.72
	RE 12025		180	152	25	3.5	2	1.5	135	166	66.9	100	2.62
	RE 13015		160	146	15	3	1.6	0.6	137	153	25	46.7	0.72
130	RE 13025	130	190	162	25	3.5	2	1.5	145	176	69.5	107	2.82

Notes: The model number of a type with seals attached is RE...UU.

If a certain level of accuracy is required, this model is used for outer ring rotation.

(a) and (b) dimensions of the lubrication hole in the detailed diagram are reference values.

Model RE (Two-Piece Inner Ring Type)

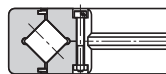
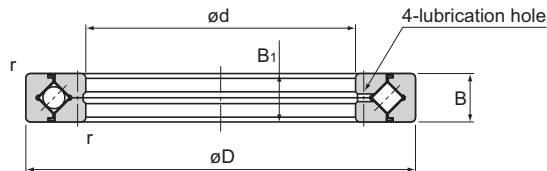

Model RE

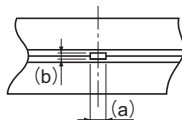
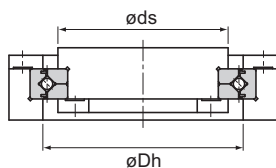

Detail view of the lubrication hole

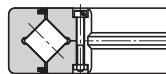

Model RE...UU

Unit: mm

Shaft diameter	Model No.	Main dimensions							Shoulder height		Basic load rating (radial)		Mass kg
		Inner diameter d	Outer diameter D	Roller pitch circle diameter dp	Width B B ₁	Lubrication hole		r_{min}	ds (max)	Dh (min)	C kN	C ₀ kN	
						a	b						
140	RE 14016	140	175	156.8	16	3	1.6	1	151	167	25.9	50.1	1
	RE 14025		200	172	25	3.5	2	1.5	154	186	74.8	121	2.96
150	RE 15013	150	180	166	13	2.5	1.6	0.6	158	173	27	53.5	0.68
	RE 15025		210	182	25	3.5	2	1.5	164	196	76.8	128	3.16
	RE 15030		230	192	30	4.5	3	1.5	173	210	100	156	5.3
160	RE 16025	160	220	192	25	3.5	2	1.5	174	206	81.7	135	3.14
170	RE 17020	170	220	196.1	20	3.5	1.6	1.5	187	204	29	62.1	2.21
180	RE 18025	180	240	210	25	3.5	2	1.5	195	225	84	143	3.44
190	RE 19025	190	240	219	25	3.5	1.6	1	207	229	41.7	82.9	2.99
200	RE 20025	200	260	230	25	3.5	2	2	215	245	84.2	157	4
	RE 20030		280	240	30	4.5	3	2	221	258	114	200	6.7
	RE 20035		295	247.7	35	5	3	2	225	270	151	252	9.6
220	RE 22025	220	280	250.1	25	3.5	2	2	235	265	92.3	171	4.1
240	RE 24025	240	300	272.5	25	3.5	2	2.5	258	284	68.3	145	4.5
250	RE 25025	250	310	280.9	25	3.5	2	2.5	268	293	69.3	150	5
	RE 25030		330	287.5	30	4.5	3	2.5	269	306	126	244	8.1
	RE 25040		355	300.7	40	6	3.5	2.5	275	326	195	348	14.8
300	RE 30025	300	360	332	25	3.5	2	2.5	319	344	75.5	178	5.9
	RE 30035		395	345	35	5	3	2.5	322	368	183	367	13.4
	RE 30040		405	351.6	40	6	3.5	2.5	326	377	212	409	17.2
350	RE 35020	350	400	376.6	20	3.5	1.6	2.5	365	386	54.1	143	3.9

Notes: The model number of a type with seals attached is RE...UU.

If a certain level of accuracy is required, this model is used for outer ring rotation.

(a) and (b) dimensions of the lubrication hole in the detailed diagram are reference values.

Model number coding

RE8016 UU CC0 P4

Model number

Accuracy symbol²Radial clearance symbol¹

Seal attached on both ends (seal attached on either end: U)

¹ See **A18-18**. ² See **A18-13**.

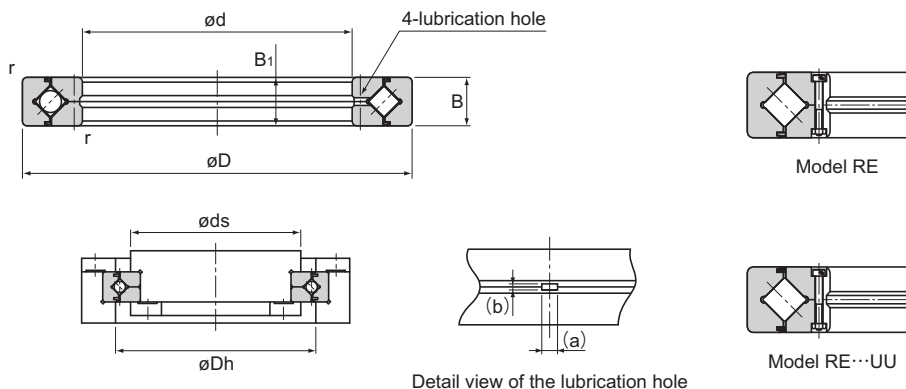

Unit: mm

Shaft diameter	Model No.	Main dimensions							Shoulder height		Basic load rating (radial)		Mass
		Inner diameter d	Outer diameter D	Roller pitch circle diameter dp	Width B B ₁	Lubrication hole		r _{min}	ds (max)	Dh (min)	C	C ₀	
						a	b						
400	RE 40035	400	480	440.3	35	5	3	2.5	422	459	156	370	14.5
	RE 40040		510	453.4	40	6	3.5	2.5	428	479	241	531	23.5
450	RE 45025	450	500	476.6	25	3.5	1.6	1	465	486	61.7	182	6.6
500	RE 50025	500	550	526.6	25	3.5	1.6	1	515	536	65.5	201	7.3
	RE 50040		600	548.8	40	6	3	2.5	526	572	239	607	26
	RE 50050		625	561.6	50	6	3.5	2.5	536	587	267	653	41.7
600	RE 60040	600	700	650	40	6	3	3	627	673	264	721	29

Notes: The model number of a type with seals attached is RE...UU.

If a certain level of accuracy is required, this model is used for outer ring rotation.

(a) and (b) dimensions of the lubrication hole in the detailed diagram are reference values.

Model number coding

RE50025 UU CC0 P6

Model number

Accuracy symbol²Radial clearance symbol¹

Seal attached on both ends (seal attached on either end: U)

¹ See **A18-18**. ² See **A18-13**.

USP-Grade Models RB and RE

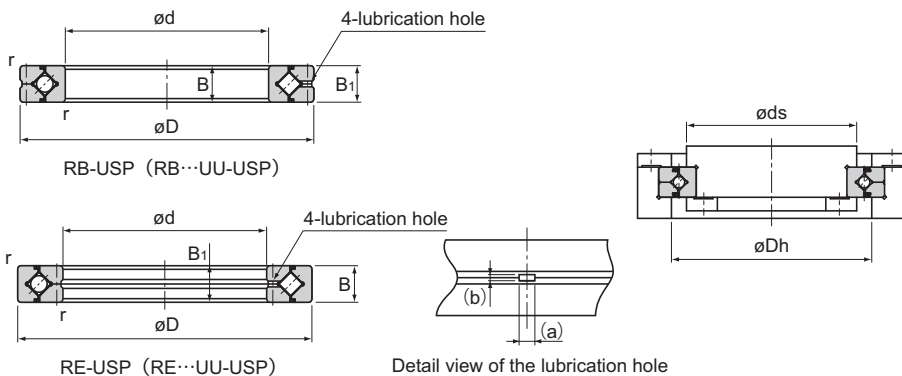

Unit: mm

Model No.	Main dimensions							Shoulder height		Basic load rating (radial)		Mass	
	Inner diameter d	Outer diameter D	Roller pitch circle diameter dp		Width B, B ₁	Lubrication hole		r _{min}	ds (max)	Dh (min)	C kN		C ₀ kN
			RB	RE		a	b						
RB 10020USP RE 10020USP	100	150	123	127	20	3.5	1.6	1	113	133	33.1	50.9	1.45
RB 12025USP RE 12025USP	120	180	148.7	152	25	3.5	2	1.5	133	164	66.9	100	2.62
RB 15025USP RE 15025USP	150	210	178	182	25				164	194	76.8	128	3.16
RB 20030USP RE 20030USP	200	280	240	240	30	4.5	3	2	221	258	114	200	6.7
RB 25030USP RE 25030USP	250	330	287.5	287.5	30				269	306	126	244	8.1
RB 30035USP RE 30035USP	300	395	345	345	35	5	3	2.5	322	368	183	367	13.4
RB 40040USP RE 40040USP	400	510	453.4	453.4	40	6	3.5		428	479	241	531	23.5
RB 50040USP RE 50040USP	500	600	548.8	548.8	40	6	3		526	572	239	607	26
RB 60040USP RE 60040USP	600	700	650	650	40			3	627	673	264	721	29

Notes: The model number of a type with seals attached is RB...UU-USP or RE...UU-USP.

If a certain level of rotational accuracy is required for the inner ring, select Model RB; if a certain level of rotational accuracy is required for the outer ring, select Model RE.

(a) and (b) dimensions of the lubrication hole in the detailed diagram are reference values.

Model number coding

RB50040 UU CC0 USP

Model number

Accuracy symbol (Ultra precision grade)

Radial clearance symbol¹

Seal attached on both ends (seal attached on either end: U)

¹ See **A18-18**.