

CSR

Cross LM Guide Model CSR

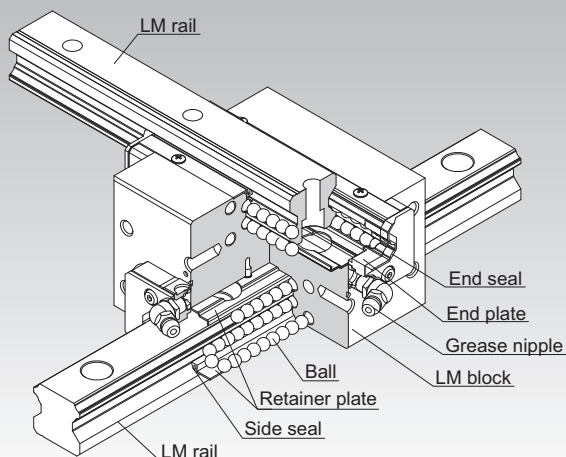

Selection Criteria **A1-10**

Design Highlights **A1-482**

Options **A1-507**

Model No. **A1-577**

Handling Precautions **A1-583**

Accessories for Lubrication **A24-1**

Mounting Procedure **B1-89**

Equivalent Moment Factor **A1-43**

Rated Loads in All Directions **A1-61**

Equivalent Factor in Each Direction **A1-63**

Radial Clearance **A1-74**

Accuracy Standards **A1-82**

Shoulder Height of the Mounting Base and the Corner Radius **A1-491**

Reference Error Tolerance for the Mounting Surface **A1-498**

Dimensions of Each Model with Options Attached **A1-521**

Structure and Features

Balls roll in four rows of raceways precision-ground on an LM rail and an LM block, and end plates incorporated in the LM block allow the balls to circulate. Since retainer plates hold the balls, they will not fall out even if the LM block is removed from the LM rail.

This LM Guide has two rails intersecting at right angles integrated back-to-back into a single block with the same internal structure as the proven LM Guide Model HSR. It is machined with high precision so that the error in the perpendicularity of the six faces of the LM block is within 2 μm per 100 mm. The two rails are also machined with high precision in relative straightness. This results in extremely high orthogonal accuracy. Because an orthogonal LM System can be achieved with the Model CSR alone, conventional saddles are no longer necessary, enabling simplified X-Y motion and a compact structure.

4-Way Equal Load

Each row of balls is placed at a contact angle of 45° so that the load ratings applied to the LM block are uniform in the four directions (radial, reverse-radial, and lateral directions), enabling the LM Guide to be used in all orientations.

High Rigidity

Since the balls are well balanced in four rows, this model is able to withstand moments, and it achieves smooth linear motion even when a preload is applied to increase the rigidity.

The rigidity of the single LM block is 50% higher than that of a combination of two HSR LM blocks secured back-to-back with bolts. That makes this model optimal for building an X-Y table that requires high rigidity.

Types and Features

Model CSR-S

This model is the standard type.

Dimensional Table⇒[A1-316](#)

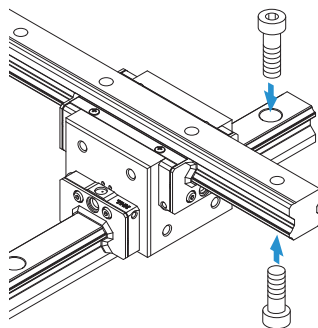

Model CSR

It has a longer overall LM block length (L) and a greater load rating.

Dimensional Table⇒[A1-316](#)

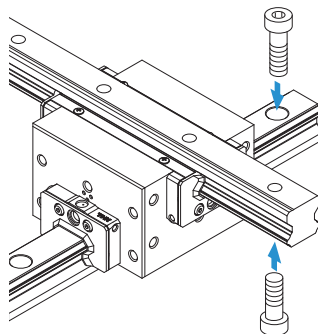

Using an Inner Saddle

The Model CSR can easily be assembled and adjusted by using an inner saddle to link four LM blocks together. When installed on an inner saddle, the Model CSR becomes a highly accurate X-Y guide and achieves high rigidity moment in the yawing direction θ (as indicated by the arrow in the figure).

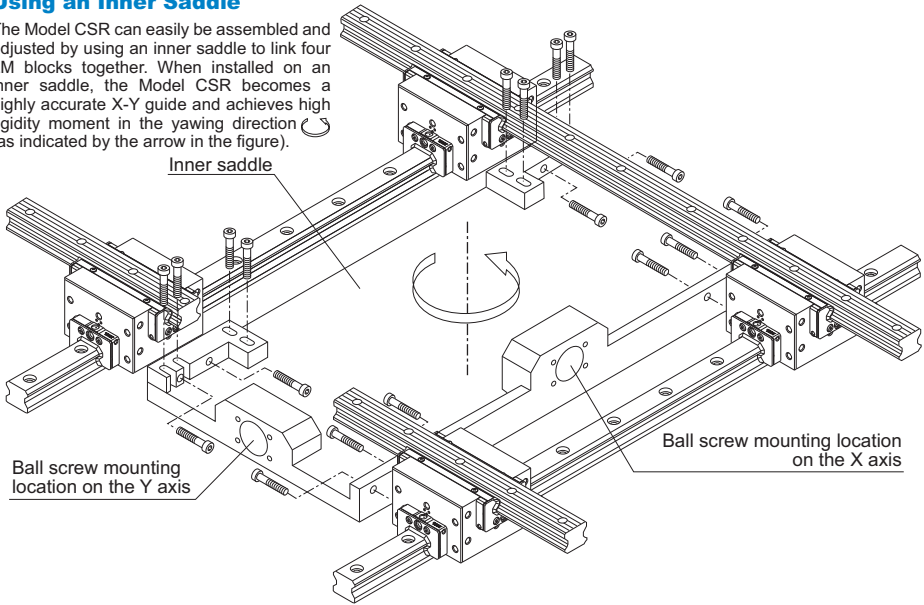

Model CSR

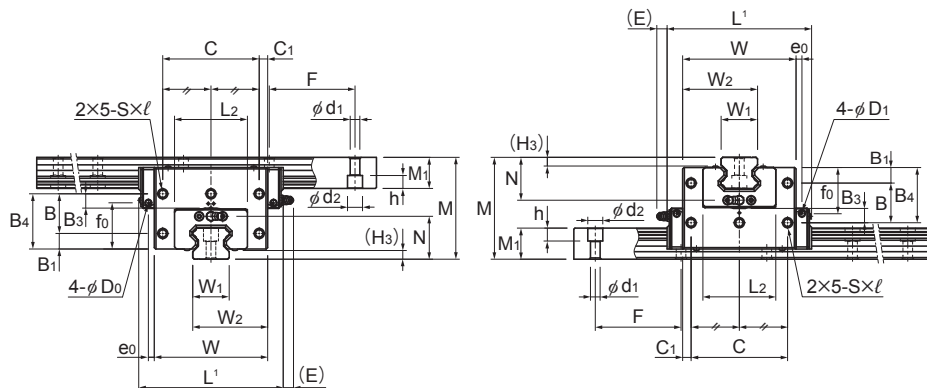

Models CSR20 to 45

Model No.	Outer dimensions			LM block dimensions														Grease nipple
	Height	Width	Length	B ₁	B ₃	B ₄	B	C	C ₁	S × ℓ	L ₂	N	E	e ₀	f ₀	D ₀		
	M	W	L															
CSR 15	47	38.8	56.6	—	11.0	34.8	—	20	9.4	M4 × 6	32	19.7	5.5	3.2	22.1	3	PB1021B	
CSR 20S CSR 20	57	50.8 66.8	74 90	— 13	12.7 7.2	42.5 37	— 24	30 56	10.4 5.4	M5 × 8	42	25	12	3.1	24.8	3	B-M6F	
CSR 25S CSR 25	70	59.5 78.6	83.1 102.2	— 18	16.4 8.4	52 44	— 26	34 64	12.75 7.3	M6 × 10	46	30	12	3.5	30.5	3	B-M6F	
CSR 30S CSR 30	82	70.4 93	98 120.6	— 21	19.4 11.4	61 53	— 32	40 76	15.2 8.5	M6 × 10	58	35	12	5.2	38.2	5.2	B-M6F	
CSR 35	95	105.8	134.8	24	13.3	61	37	90	7.9	M8 × 14	68	40	12	5.5	43.1	5.2	B-M6F	
CSR 45	118	129.8	170.8	30	15.4	75	45	110	9.9	M10 × 15	84	50	16	6.4	53.1	5.2	B-PT1/8	

Model number coding

4 CSR25 UU C0 +1240/1000L P

4	CSR25	UU	C0	+1240/1000L	P
Model number	Contamination protection accessory symbol	LM rail length on the X axis (in mm)	LM rail length on the Y axis (in mm)		
Total No. of LM blocks	Radial clearance symbol Normal (No symbol)/Light preload (C1) Medium preload (C0)			Accuracy symbol Precision grade (P)/Super precision grade (SP) Ultra precision grade (UP)	

Notes: See contamination protection accessories on **A1-547**. See **A1-74** for radial clearance symbol. See **A1-82** for accuracy symbol.

Standard Lengths and Maximum Lengths of LM Rails

Table 1 shows the standard lengths and the maximum lengths of model CSR variations. For special rail lengths, it is recommended to use a value corresponding to the G and g dimensions from the table. As the G and g dimensions increase, this portion becomes less stable, and the accuracy performance is severely impacted.

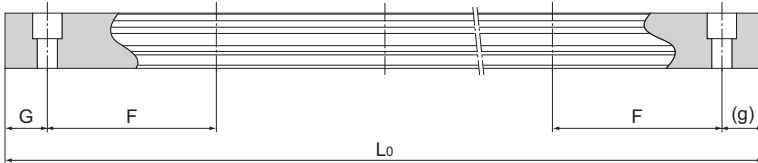

Table 1: Standard Lengths and Maximum Lengths of LM Rails for Model CSR

Unit: mm

Model No.	CSR 15	CSR 20	CSR 25	CSR 30	CSR 35	CSR 45
LM rail standard lengths (L_0)	160	220	220	280	280	570
	220	280	280	360	360	675
	280	340	340	440	440	780
	340	400	400	520	520	885
	400	460	460	600	600	990
	460	520	520	680	680	1095
	520	580	580	760	760	1200
	580	640	640	840	840	1305
	640	700	700	920	920	1410
	700	760	760	1000	1000	1515
	760	820	820	1080	1080	1620
	820	940	940	1160	1160	1725
	940	1000	1000	1240	1240	1830
	1000	1060	1060	1320	1320	1935
	1060	1120	1120	1400	1400	2040
	1120	1180	1180	1480	1480	2145
	1180	1240	1240	1560	1560	2250
	1240	1360	1300	1640	1640	2355
	1360	1480	1360	1720	1720	2460
	1480	1600	1420	1800	1800	2565
1600	1720	1480	1880	1880	2670	
	1840	1540	1960	1960	2775	
	1960	1600	2040	2040	2880	
	2080	1720	2200	2200	2985	
	2200	1840	2360	2360	3090	
		1960	2520	2520		
		2080	2680	2680		
		2200	2840	2840		
		2320	3000	3000		
		2440				
Standard pitch F	60	60	60	80	80	105
G, g	20	20	20	20	20	22.5
Max length	3000	3000	3000	3000	3000	3090

Note: The maximum length varies with accuracy grades. Contact THK for details.

Tapped-Hole Type LM Rail

CSR model rails also include a type where the LM rail is tapped from the bottom. With the X-axis LM rail having tapped holes, this model can be secured with bolts from the top.

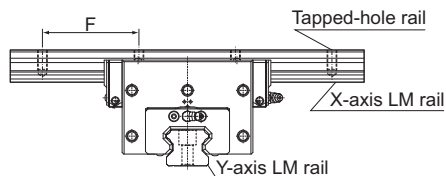

Table 2: Dimensions of the LM Rail Tap Unit: mm

Model No.	S ₁	Effective tap depth l_1
15	M5	8
20	M6	10
25	M6	12
30	M8	15
35	M8	17
45	M12	24

Model number coding

4CSR25UUC0+1200LP K /1000LP

Symbol for
tapped-hole LM rail type