



# Slide Rail

THK General Catalog

## A Product Descriptions

|   |        |
|---|--------|
| <b>Features and Types</b> .....           | A13-2  |
| Features of the Slide Rail .....          | A13-2  |
| • Structure and Features .....            | A13-2  |
| Slide Rail Types .....                    | A13-3  |
| • Types and Features .....                | A13-3  |
| Classification Table for Slide Rails..... | A13-12 |

### Dimensional Drawing, Dimensional Table

|                         |        |
|-------------------------|--------|
| Model FBL 27S .....     | A13-14 |
| Model FBL 27S-P14 ..... | A13-15 |
| Model FBL 35S .....     | A13-16 |
| Model FBL 35S-P13 ..... | A13-17 |
| Model FBL 35S-P14 ..... | A13-18 |
| Model FBL 35M .....     | A13-19 |
| Model FBL 35J .....     | A13-20 |
| Model FBL 35B .....     | A13-21 |
| Model FBL 27D .....     | A13-22 |
| Model FBL 35N .....     | A13-24 |
| Model FBL 35N-P16 ..... | A13-25 |
| Model FBL 35G-P13 ..... | A13-26 |
| Model FBL 35G-P14 ..... | A13-27 |
| Model FBL 35D .....     | A13-28 |
| Model FBL 51H .....     | A13-29 |
| Model FBL 51H-P13 ..... | A13-30 |
| Model FBL 51H-P14 ..... | A13-31 |
| Model FBL 35K .....     | A13-32 |
| Model FBL 56H .....     | A13-33 |
| Model FBL 56H-P13 ..... | A13-34 |
| Model FBL 56H-P14 ..... | A13-35 |
| Model FBL 35F .....     | A13-36 |
| Model E36RS .....       | A13-37 |
| Model E15 .....         | A13-38 |
| Model E20 .....         | A13-39 |
| Model D20 .....         | A13-40 |

|                              |        |
|------------------------------|--------|
| <b>Point of Design</b> ..... | A13-41 |
|------------------------------|--------|

|                             |        |
|-----------------------------|--------|
| <b>Model No.</b> .....      | A13-43 |
| • Model Number Coding ..... | A13-43 |

|                                 |        |
|---------------------------------|--------|
| <b>Precautions on Use</b> ..... | A13-44 |
|---------------------------------|--------|

## B Support Book (Separate)

|   |        |
|---|--------|
| <b>Features and Types</b> .....           | B13-2  |
| Features of the Slide Rail .....          | B13-2  |
| • Structure and Features .....            | B13-2  |
| Slide Rail Types .....                    | B13-3  |
| • Types and Features .....                | B13-3  |
| Classification Table for Slide Rails..... | B13-12 |

|                                 |        |
|---------------------------------|--------|
| <b>Mounting Procedure</b> ..... | B13-14 |
| Mounting the Slide Rail.....    | B13-14 |

|                             |        |
|-----------------------------|--------|
| <b>Model No.</b> .....      | B13-17 |
| • Model Number Coding ..... | B13-17 |

|                                 |        |
|---------------------------------|--------|
| <b>Precautions on Use</b> ..... | B13-18 |
|---------------------------------|--------|

## Features of the Slide Rail

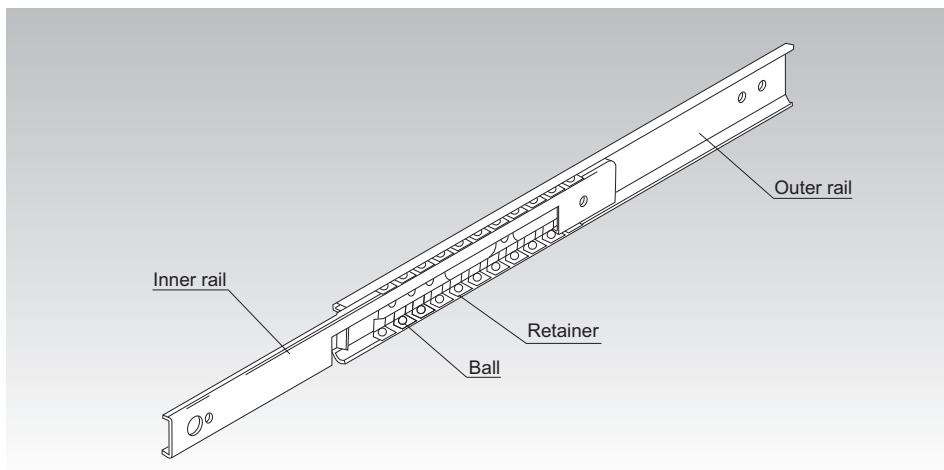

Fig.1 Structure of Slide Rail Model FBL

### Structure and Features

Slide rails are low-price finite linear guides made out of precision roll-formed steel plates. They are suitable as linear motion guides for various applications because they are thin, compact, and easy to mount. Slide rails can be used in a wide range of applications such as photocopiers, measuring instruments, telecommunications equipment, medical equipment, automatic vending machines, and various types of office equipment.

The Model FBL slide rail has two rows of ball bearings placed between an inner rail and an outer rail that have been roll-formed out of steel plates. The ball bearings are evenly spaced by a precisely press-molded retainer, eliminating friction between the bearings and achieving a smooth sliding mechanism.

#### [Allows Easy Installation]

Simple to mount on the mounting surface. Since retainers hold the bearings, they do not fall out even if the inner rail is removed.

#### [Thin and Compact]

The thin cross section of the Model FBL slide rail means it can be installed in small spaces, and it is suitable for places where space saving is required.

#### [High Corrosion Resistance]

The Model FBL slide rail is treated with zinc plating, and models E and D are treated with a white anodized aluminum coating, making them highly corrosion-resistant.

# Slide Rail Types

## Types and Features

[Single Slides for Light Load]

### Model FBL 27S

The most compact slide rail.

Specification Table⇒ **A** 13-14

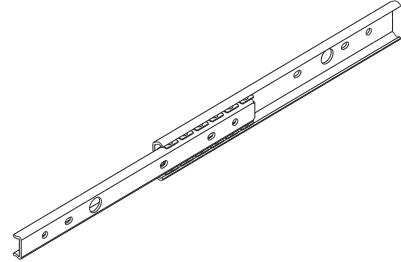

Model FBL 27S

### Model FBL 27S-P14

The Model FBL 27S features a removable inner rail. When retracted, the inner rail can be automatically unlocked by pushing it further into the outer rail.

Specification Table⇒ **A** 13-15

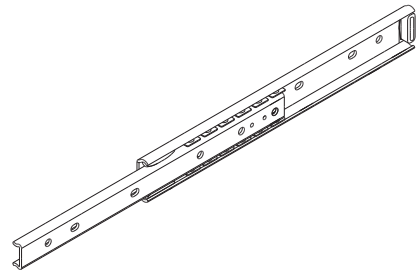

Model FBL 27S-P14

### Model FBL 35S

A single slide type of slide rail with the most fundamental shape.

Specification Table⇒ **A** 13-16

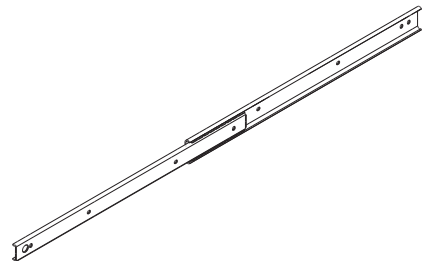

Model FBL 35S

## Model FBL 35S-P13

The Model FBL 35S features a removable inner rail. When retracted, it can be unlocked manually.

Specification Table⇒ [A13-17](#)

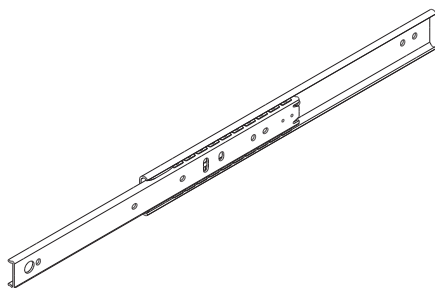

Model FBL 35S-P13

## Model FBL 35S-P14

The Model FBL 35S features a removable inner rail. When retracted, the inner rail can be automatically unlocked by pushing it further into the outer rail.

Specification Table⇒ [A13-18](#)

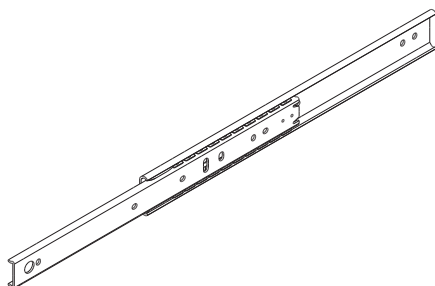

Model FBL 35S-P14

## Model FBL 35M

The Model FBL 35S features a removable inner rail. The slide rail is designed to stop by frictional resistance when it is fully opened. Remove the inner rail by applying more force. (Includes a brake stop)

Specification Table⇒ [A13-19](#)

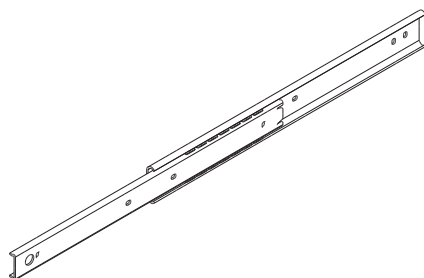

Model FBL 35M

## Features and Types

### Slide Rail Types

#### Model FBL 35J

The Model FBL 35M with additional lead ball that serves as a guide when the inner rail is inserted.

Specification Table⇒ **A** 13-20

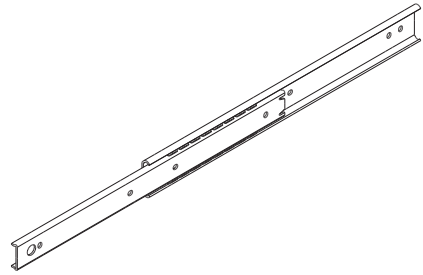

Model FBL 35J

#### Model FBL 35B

The Model FBL 35M with additional mounting bracket.

Specification Table⇒ **A** 13-21

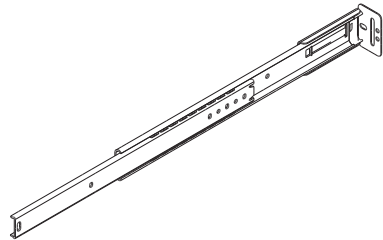

Model FBL 35B

### [Double Slides for Light Load]

## Model FBL 27D

A double slide with an additional Model FBL 27S attached on the rear side of the inner rail. Widely used in many types of OA equipment.

Specification Table⇒ **A13-22**

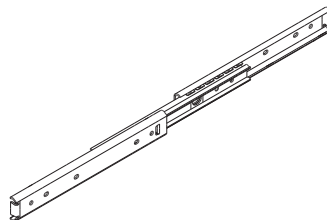

Model FBL 27D

## Model FBL 35N

This is a three-rail double slide that allows a long stroke in a small space.

This product uses a plate thickness of 1.2 mm and a light-load double slide rail to achieve weight reduction.

Specification Table⇒ **A13-24**



Model FBL 35N

## Model FBL 35N-P16

This is a three-rail double slide that allows a long stroke in a small space. It uses a plate thickness of 1.2 mm and a light-load double slide rail to achieve weight reduction. The inner rail can be pulled out, and it can be reinserted smoothly without the need for a release operation.

Specification Table⇒ **A13-25**

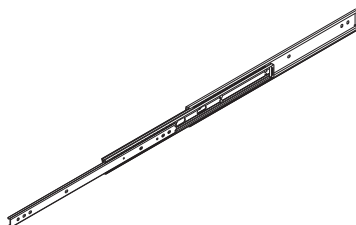

Model FBL 35N-P16

## Features and Types

### Slide Rail Types

#### [Double Slides for Medium Load]

### Model FBL 35G-P13

A double slide with an additional Model FBL 35S attached on the front side. The drawer rail can be pulled out, and it can be manually unlocked when retracted. It is also equipped with a useful locking mechanism that engages when the slide rail is fully opened.

Specification Table⇒ **A** 13-26

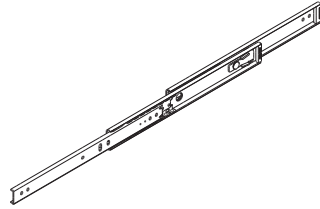

Model FBL 35G-P13

### Model FBL 35G-P14

A double slide with an additional Model FBL 35S attached on the front side. The drawer rail can be pulled out, and it can be automatically unlocked by pushing it further into the outer rail. It is also equipped with a useful locking mechanism that engages when the slide rail is fully opened.

Specification Table⇒ **A** 13-27

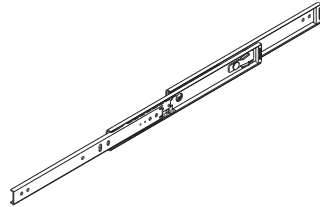

Model FBL 35G-P14

### Model FBL 35D

A double slide with an additional Model FBL 35S attached on the rear side of the inner rail. Widely used in a number of different industries.

Specification Table⇒ **A** 13-28

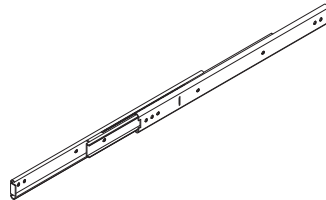

Model FBL 35D

## Model FBL 51H

A three-rail double slide that allows a long stroke. A thin model that can be used in small spaces, even with large working loads.

Specification Table⇒ **A13-29**

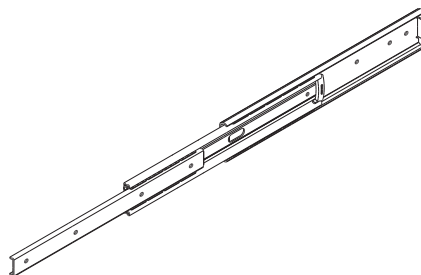

Model FBL 51H

## Model FBL 51H-P13

A three-rail double slide that allows a long stroke. A thin model that can be used in small spaces, even with large working loads. The inner rail can be pulled out, and locked states caused by the disconnection spring can be manually released when retracted. It is also equipped with a useful locking mechanism that engages when the slide rail is fully opened.

Specification Table⇒ **A13-30**

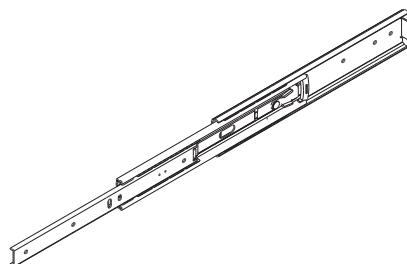

Model FBL 51H-P13

## Model FBL 51H-P14

A three-rail double slide that allows a long stroke. A thin model that can be used in small spaces, even with large working loads. The inner rail can be pulled out, and it can be automatically unlocked by pushing it further into the outer rail.

Specification Table⇒ **A13-31**

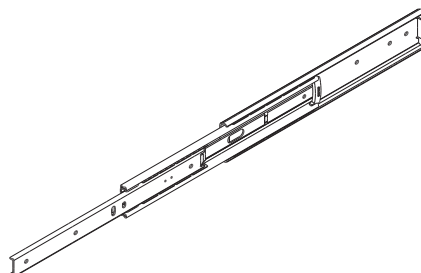

Model FBL 51H-P14

**[Double Slides for Heavy Load]****Model FBL 35K**

A double slide combining four Model FBL 35S units. It features the largest allowable load among all models, making it suitable for opening/closing heavy objects.

Specification Table⇒ **A 13-32**

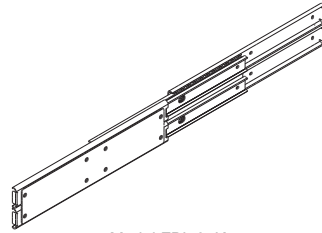

Model FBL 35K

**Model FBL 56H**

Three-rail double slide with a large allowable load. Widely used in many types of office furniture.

Specification Table⇒ **A 13-33**

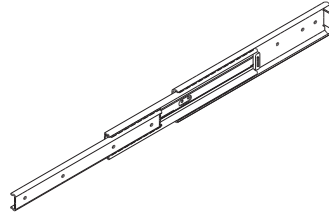

Model FBL 56H

**Model FBL 56H-P13**

Three-rail double slide with a large allowable load. The inner rail can be pulled out, and it can be manually unlocked when retracted. It is also equipped with a useful locking mechanism that engages when the slide rail is fully opened.

Specification Table⇒ **A 13-34**

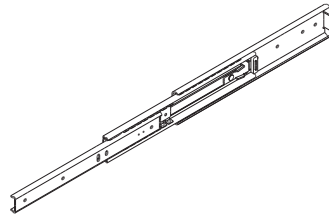

Model FBL 56H-P13

**Model FBL 56H-P14**

Three-rail double slide with a large allowable load. The inner rail can be pulled out, and it can be automatically unlocked by pushing it further into the outer rail.

Specification Table⇒ **A 13-35**

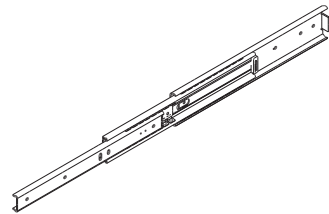

Model FBL 56H-P14

### [Linear Type Slides]

## Light Load Type Model FBL 35F

Linear-type slide suitable for limited straight motion, featuring a flange for easy mounting.

Specification Table⇒ **A13-36**

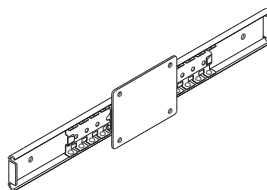

Light Load Type Model FBL 35F

### [Wheel-type Linear Slide]

## Model E36RS

A linear slide that features wear-resistant resin bearings.

Specification Table⇒ **A13-37**

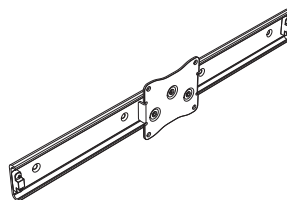

Model E36RS

**[Aluminum Alloy Slide Rail]****Light Load Type Model E15**

A compact and lightweight single slide from the aluminum alloy series. Suitable for locations within magnetic fields, locations requiring rust-resistant materials, and locations where appearance is a factor.

Specification Table⇒ **A** 13-38

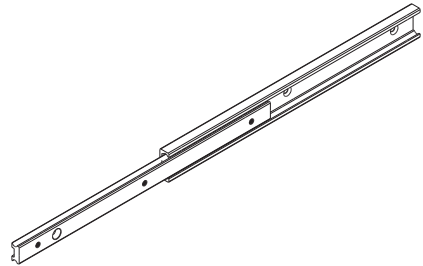

Light Load Type Model E15

**Light Load Type Model E20**

A basic single slide from the aluminum alloy series. Suitable for locations within magnetic fields, locations requiring rust-resistant materials, and locations where appearance is a factor.

Specification Table⇒ **A** 13-39

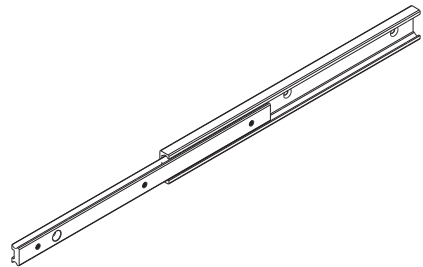

Light Load Type Model E20

**Light Load Type Model D20**

The most compact and lightweight double slide in the aluminum alloy series. Suitable for locations within magnetic fields, locations requiring rust-resistant materials, and locations where appearance is a factor.

Specification Table⇒ **A** 13-40

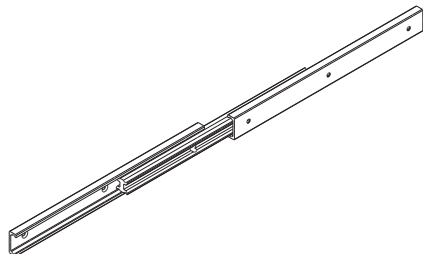

Light Load Type Model D20

# Classification Table for Slide Rails

## Slide Rail

### Single Slide

#### For Light Load

**Model FBL27S**

Model FBL27S-P14

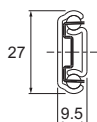

**Model FBL35J**

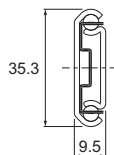

**Model FBL35S**

Model FBL35S-P13

Model FBL35S-P14

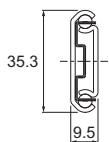

**Model FBL35B**

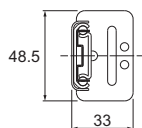

**Model E15**  
(Made of Aluminum)

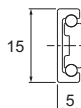

**Model FBL35M**

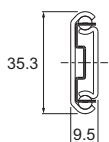

**Model E20**  
(Made of Aluminum)

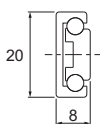

### Double Slide

#### For Light Load

**Model FBL27D**

**Model D20**  
(Made of aluminum)

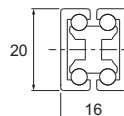
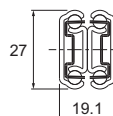

**Model FBL35N**

Model FBL35N-P16

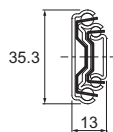

#### For Medium Load

**Model FBL35G-P13**

**Model FBL51H**

Model FBL35G-P14

Model FBL51H-P13

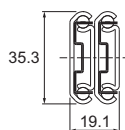

Model FBL51H-P14

**Model FBL35D**

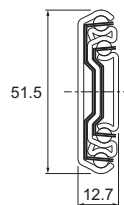
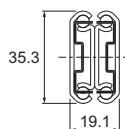

## Features and Types

### Classification Table for Slide Rails

## Linear Type Slide

### For Heavy Load

**Model FBL35K**

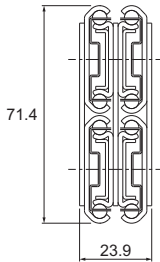

**Model FBL56H**

**Model FBL56H-P13**

**Model FBL56H-P14**

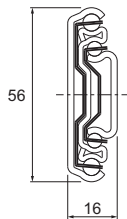

### For Light Load

**Model FBL35F**

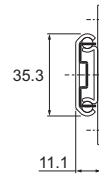

### Wheel Type

**Model E36RS (Aluminum Outer Rail)**

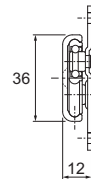

Slide Rail

# Model FBL 27S

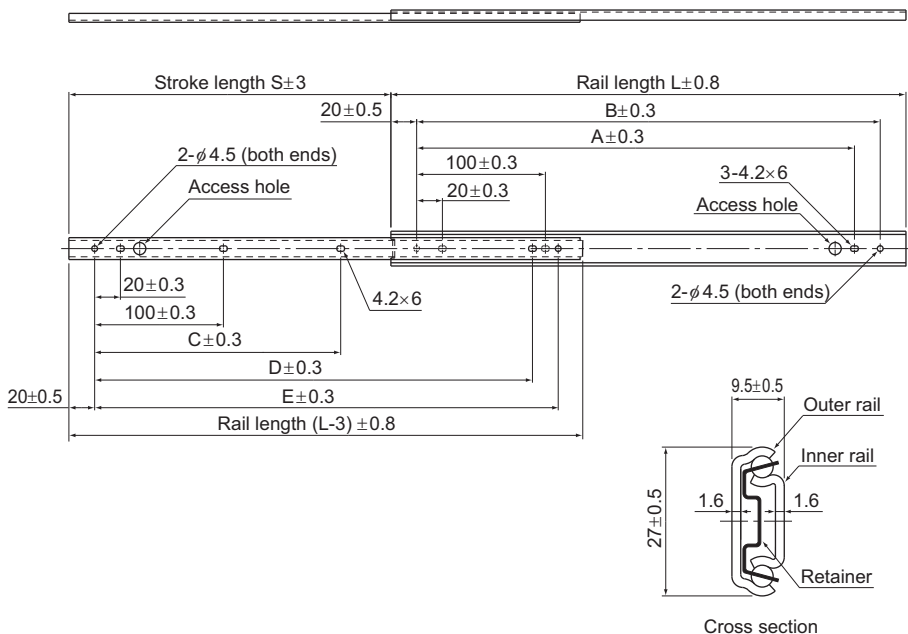

Unit: mm

| Rail length<br>L<br>( $\pm 0.8$ ) | Stroke<br>S<br>( $\pm 3$ ) | Mounting hole dimensions |     |     |     |     | Mounting hole |            | Permissible load<br>N/pair | Mass<br>kg/pair |
|-----------------------------------|----------------------------|--------------------------|-----|-----|-----|-----|---------------|------------|----------------------------|-----------------|
|                                   |                            | A                        | B   | C   | D   | E   | Inner rail    | Outer rail |                            |                 |
| 200                               | 135                        | 140                      | 160 | —   | 140 | 160 | 5             | 5          | 260                        | 0.32            |
| 250                               | 185                        | 190                      | 210 | 150 | 190 | 210 | 6             | 5          | 240                        | 0.4             |
| 300                               | 222                        | 240                      | 260 | 190 | 240 | 260 | 6             | 5          | 240                        | 0.48            |
| 350                               | 260                        | 290                      | 310 | 225 | 290 | 310 | 6             | 5          | 230                        | 0.56            |
| 400                               | 297                        | 340                      | 360 | 265 | 340 | 360 | 6             | 5          | 210                        | 0.64            |
| 450                               | 334                        | 390                      | 410 | 300 | 390 | 410 | 6             | 5          | 200                        | 0.72            |
| 500                               | 371                        | 440                      | 460 | 337 | 440 | 460 | 6             | 5          | 180                        | 0.8             |

Note: The Permissible Load and Mass each indicate when used as a pair of 2 units.

## Model number coding

**FBL27S +300L**

Model number      Overall rail length (mm)

# Model FBL 27S-P14

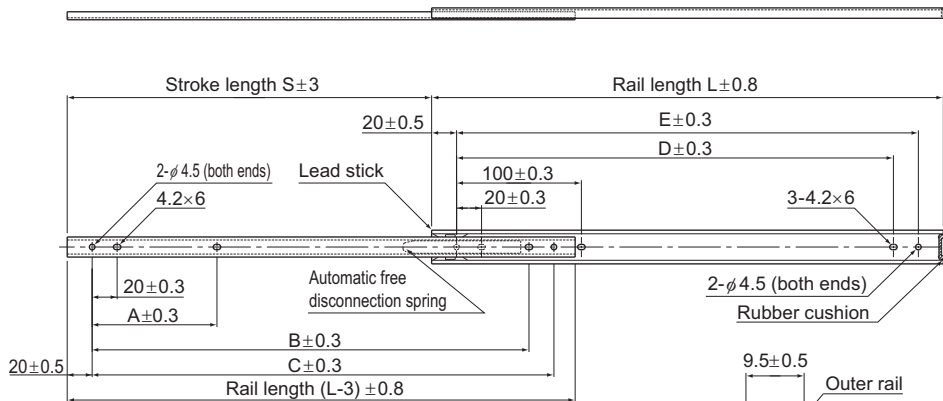

Releasing the automatic free disconnection spring attached to the inner rail allows the inner rail to be pulled out. When retracted, the inner rail can be automatically unlocked by pushing it further into the outer rail.

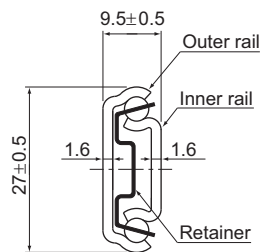

Cross section

Unit: mm

| Rail length<br>L<br>(±0.8) | Stroke<br>S<br>(±3) | Mounting hole dimensions |     |     |     |     | Mounting hole |            | Permissible load<br>N/pair | Mass<br>kg/pair |
|----------------------------|---------------------|--------------------------|-----|-----|-----|-----|---------------|------------|----------------------------|-----------------|
|                            |                     | A                        | B   | C   | D   | E   | Inner rail    | Outer rail |                            |                 |
| 200                        | 116                 | 65                       | —   | 170 | 140 | 160 | 4             | 5          | 260                        | 0.32            |
| 250                        | 152                 | 100                      | —   | 210 | 190 | 210 | 4             | 5          | 240                        | 0.4             |
| 300                        | 202                 | 100                      | —   | 260 | 240 | 260 | 4             | 5          | 240                        | 0.48            |
| 350                        | 251                 | 100                      | —   | 310 | 290 | 310 | 4             | 5          | 230                        | 0.56            |
| 400                        | 297                 | 100                      | —   | 360 | 340 | 360 | 4             | 5          | 210                        | 0.64            |
| 450                        | 332                 | 100                      | 390 | 410 | 390 | 410 | 5             | 5          | 210                        | 0.72            |
| 500                        | 371                 | 100                      | 440 | 460 | 440 | 460 | 5             | 5          | 200                        | 0.8             |
| 550                        | 407                 | 100                      | 490 | 510 | 490 | 510 | 5             | 5          | 180                        | 0.8             |

Note: The Permissible Load and Mass each indicate when used as a pair of 2 units.

## Model number coding

**FBL27S-P14 +500L**

Model number

Overall rail length (mm)

# Model FBL 35S

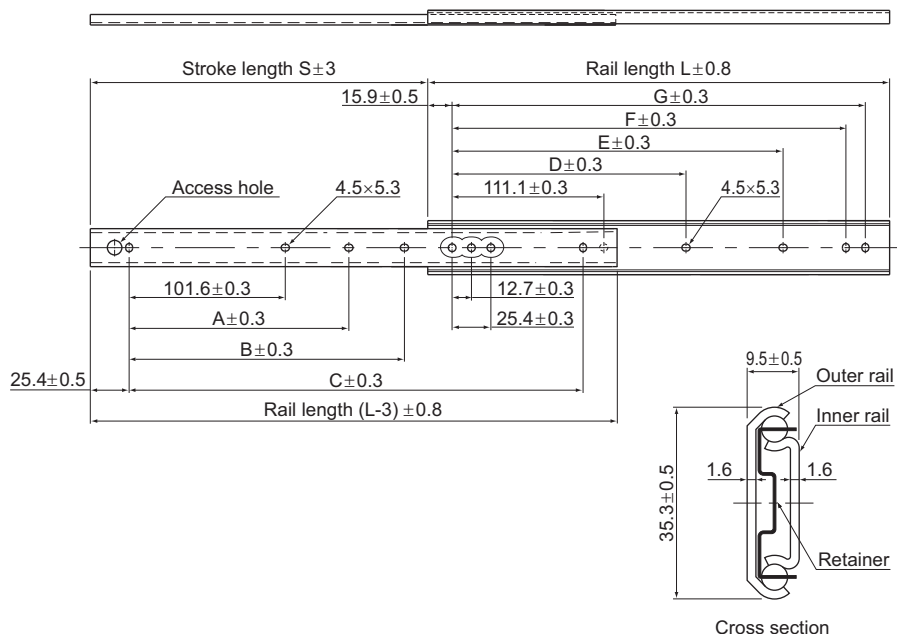

Unit: mm

| Rail length<br>L<br>(±0.8) | Stroke<br>S<br>(±3) | Mounting hole dimensions |       |       |       |       |       |       | Mounting hole |            | Permissible load<br>N/pair | Mass<br>kg/pair |
|----------------------------|---------------------|--------------------------|-------|-------|-------|-------|-------|-------|---------------|------------|----------------------------|-----------------|
|                            |                     | A                        | B     | C     | D     | E     | F     | G     | Inner rail    | Outer rail |                            |                 |
| 305                        | 229                 | —                        | 152.4 | 254   | —     | 149.2 | 260.3 | 273   | 4             | 7          | 490                        | 0.6             |
| 356                        | 279                 | —                        | 203.2 | 304.8 | —     | 200   | 311.1 | 323.8 | 4             | 7          | 400                        | 0.7             |
| 406                        | 305                 | —                        | 254   | 355.6 | —     | 250.8 | 361.9 | 374.6 | 4             | 7          | 390                        | 0.8             |
| 457                        | 330                 | 203.2                    | 304.8 | 406.4 | 212.7 | 301.6 | 412.7 | 425.4 | 5             | 8          | 380                        | 0.9             |
| 508                        | 381                 | 228.6                    | 355.6 | 457.2 | 238.1 | 352.4 | 463.5 | 476.2 | 5             | 8          | 330                        | 1               |
| 559                        | 406                 | 254                      | 406.4 | 508   | 263.5 | 403.2 | 514.3 | 527   | 5             | 8          | 320                        | 1.1             |
| 610                        | 432                 | 279.4                    | 457.2 | 558.8 | 288.9 | 454   | 565.1 | 577.8 | 5             | 8          | 310                        | 1.2             |
| 660                        | 483                 | 304.8                    | 508   | 609.6 | 314.3 | 504.8 | 615.9 | 628.6 | 5             | 8          | 280                        | 1.3             |
| 711                        | 508                 | 330.2                    | 558.8 | 660.4 | 339.7 | 555.6 | 666.7 | 679.4 | 5             | 8          | 270                        | 1.4             |

Note: The Permissible Load and Mass each indicate when used as a pair of 2 units.

## Model number coding

### FBL35S +457L

Model number      Overall rail length (mm)

# Model FBL 35S-P13

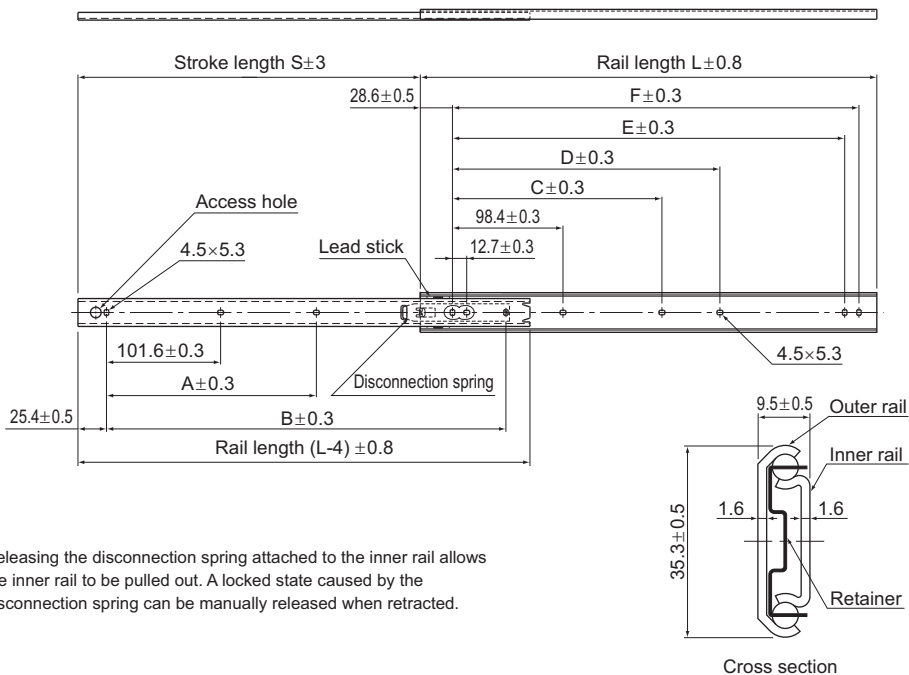

Releasing the disconnection spring attached to the inner rail allows the inner rail to be pulled out. A locked state caused by the disconnection spring can be manually released when retracted.

Unit: mm

| Rail length<br>L<br>(±0.8) | Stroke<br>S<br>(±3) | Mounting hole dimensions |       |       |       |       |       | Mounting hole |            | Permissible load<br>N/pair | Mass<br>kg/pair |
|----------------------------|---------------------|--------------------------|-------|-------|-------|-------|-------|---------------|------------|----------------------------|-----------------|
|                            |                     | A                        | B     | C     | D     | E     | F     | Inner rail    | Outer rail |                            |                 |
| 305                        | 224                 | 152.4                    | —     | 136.5 | —     | 247.6 | 260.3 | 3             | 6          | 490                        | 0.6             |
| 356                        | 275                 | 203.2                    | —     | 187.3 | —     | 298.4 | 311.1 | 3             | 6          | 400                        | 0.72            |
| 406                        | 315                 | 254                      | —     | 238.1 | —     | 349.2 | 361.9 | 3             | 6          | 390                        | 0.84            |
| 457                        | 330                 | 203.2                    | 406.4 | 200   | 288.9 | 400   | 412.7 | 4             | 7          | 380                        | 0.96            |
| 508                        | 381                 | 228.6                    | 457.2 | 225.4 | 339.7 | 450.8 | 463.5 | 4             | 7          | 330                        | 1.04            |
| 559                        | 406                 | 254                      | 508   | 250.8 | 390.5 | 501.6 | 514.3 | 4             | 7          | 320                        | 1.16            |
| 610                        | 432                 | 279.4                    | 558.8 | 276.2 | 441.3 | 552.4 | 565.1 | 4             | 7          | 310                        | 1.24            |
| 660                        | 483                 | 304.8                    | 609.6 | 301.6 | 492.1 | 603.2 | 615.9 | 4             | 7          | 280                        | 1.36            |
| 711                        | 493                 | 330.2                    | 660.4 | 327   | 542.9 | 654   | 666.7 | 4             | 7          | 270                        | 1.48            |

Note: The Permissible Load and Mass each indicate when used as a pair of 2 units.

## Model number coding

**FBL35S-P13 +559L**

Model number

Overall rail length (mm)

# Model FBL 35S-P14

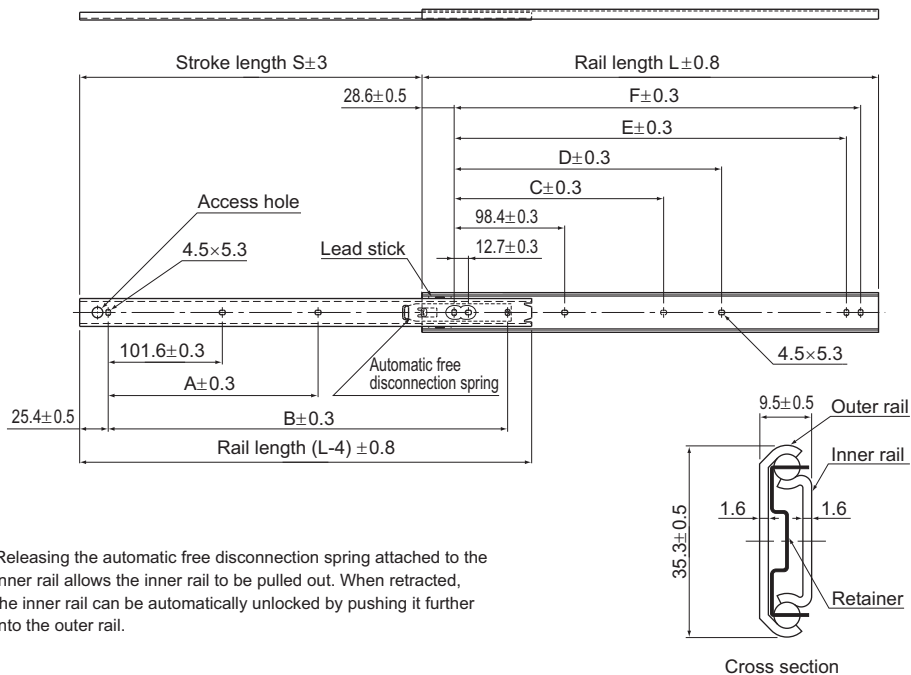

Releasing the automatic free disconnection spring attached to the inner rail allows the inner rail to be pulled out. When retracted, the inner rail can be automatically unlocked by pushing it further into the outer rail.

Unit: mm

| Rail length<br>L<br>(±0.8) | Stroke<br>S<br>(±3) | Mounting hole dimensions |       |       |       |       |       | Mounting hole |            | Permissible load<br>N/pair | Mass<br>kg/pair |
|----------------------------|---------------------|--------------------------|-------|-------|-------|-------|-------|---------------|------------|----------------------------|-----------------|
|                            |                     | A                        | B     | C     | D     | E     | F     | Inner rail    | Outer rail |                            |                 |
| 305                        | 224                 | 152.4                    | —     | 136.5 | —     | 247.6 | 260.3 | 3             | 6          | 490                        | 0.6             |
| 356                        | 275                 | 203.2                    | —     | 187.3 | —     | 298.4 | 311.1 | 3             | 6          | 400                        | 0.72            |
| 406                        | 315                 | 254                      | —     | 238.1 | —     | 349.2 | 361.9 | 3             | 6          | 390                        | 0.84            |
| 457                        | 330                 | 203.2                    | 406.4 | 200   | 288.9 | 400   | 412.7 | 4             | 7          | 380                        | 0.96            |
| 508                        | 381                 | 228.6                    | 457.2 | 225.4 | 339.7 | 450.8 | 463.5 | 4             | 7          | 330                        | 1.04            |
| 559                        | 406                 | 254                      | 508   | 250.8 | 390.5 | 501.6 | 514.3 | 4             | 7          | 320                        | 1.16            |
| 610                        | 432                 | 279.4                    | 558.8 | 276.2 | 441.3 | 552.4 | 565.1 | 4             | 7          | 310                        | 1.24            |
| 660                        | 483                 | 304.8                    | 609.6 | 301.6 | 492.1 | 603.2 | 615.9 | 4             | 7          | 280                        | 1.36            |
| 711                        | 493                 | 330.2                    | 660.4 | 327   | 542.9 | 654   | 666.7 | 4             | 7          | 270                        | 1.48            |

Note: The Permissible Load and Mass each indicate when used as a pair of 2 units.

## Model number coding

### FBL35S-P14 +559L

Model number

Overall rail length (mm)

# Model FBL 35M

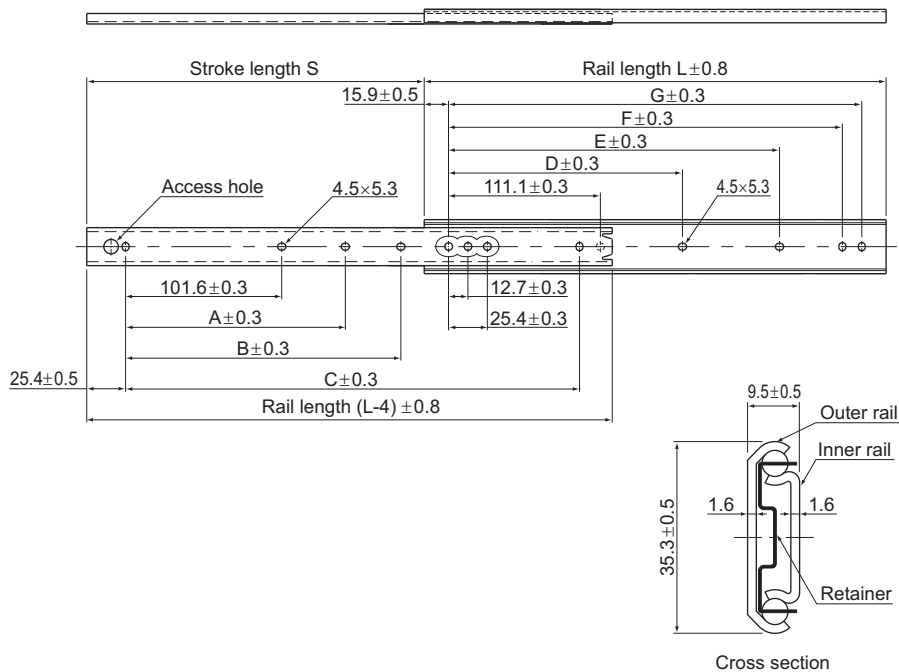

Cross section

Unit: mm

| Rail length<br>L<br>(±0.8) | Stroke<br>S | Mounting hole dimensions |       |       |       |       |       |       | Mounting hole |            | Permissible load<br>N/pair | Mass<br>kg/pair |
|----------------------------|-------------|--------------------------|-------|-------|-------|-------|-------|-------|---------------|------------|----------------------------|-----------------|
|                            |             | A                        | B     | C     | D     | E     | F     | G     | Inner rail    | Outer rail |                            |                 |
| 305                        | 229         | —                        | 152.4 | 254   | —     | 149.2 | 260.3 | 273   | 4             | 7          | 490                        | 0.6             |
| 356                        | 279         | —                        | 203.2 | 304.8 | —     | 200   | 311.1 | 323.8 | 4             | 7          | 400                        | 0.7             |
| 406                        | 305         | —                        | 254   | 355.6 | —     | 250.8 | 361.9 | 374.6 | 4             | 7          | 390                        | 0.8             |
| 457                        | 330         | 203.2                    | 304.8 | 406.4 | 212.7 | 301.6 | 412.7 | 425.4 | 5             | 8          | 380                        | 0.9             |
| 508                        | 381         | 228.6                    | 355.6 | 457.2 | 238.1 | 352.4 | 463.5 | 476.2 | 5             | 8          | 330                        | 1               |
| 559                        | 406         | 254                      | 406.4 | 508   | 263.5 | 403.2 | 514.3 | 527   | 5             | 8          | 320                        | 1.1             |
| 610                        | 432         | 279.4                    | 457.2 | 558.8 | 288.9 | 454   | 565.1 | 577.8 | 5             | 8          | 310                        | 1.2             |
| 660                        | 483         | 304.8                    | 508   | 609.6 | 314.3 | 504.8 | 615.9 | 628.6 | 5             | 8          | 280                        | 1.3             |
| 711                        | 508         | 330.2                    | 558.8 | 660.4 | 339.7 | 555.6 | 666.7 | 679.4 | 5             | 8          | 270                        | 1.4             |

Note: The Permissible Load and Mass each indicate when used as a pair of 2 units.

## Model number coding

**FBL35M +406L**

Model number      Overall rail length (mm)

# Model FBL 35J

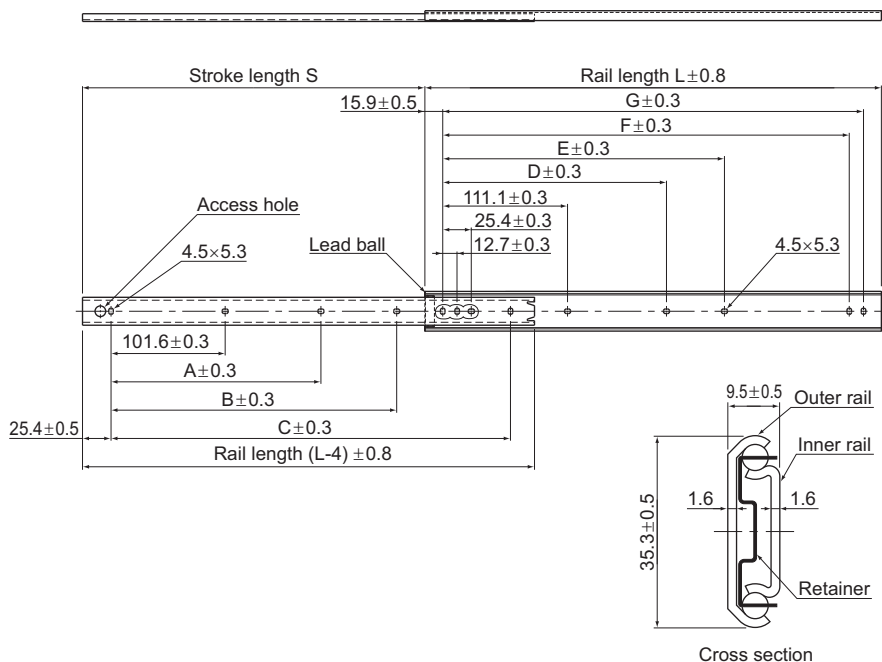

Unit: mm

| Rail length<br>L<br>(±0.8) | Stroke<br>S | Mounting hole dimensions |       |       |       |       |       |       | Mounting hole |            | Permissible load<br>N/pair | Mass<br>kg/pair |
|----------------------------|-------------|--------------------------|-------|-------|-------|-------|-------|-------|---------------|------------|----------------------------|-----------------|
|                            |             | A                        | B     | C     | D     | E     | F     | G     | Inner rail    | Outer rail |                            |                 |
| 305                        | 229         | —                        | 152.4 | 254   | —     | 149.2 | 260.3 | 273   | 4             | 7          | 490                        | 0.6             |
| 356                        | 279         | —                        | 203.2 | 304.8 | —     | 200   | 311.1 | 323.8 | 4             | 7          | 400                        | 0.7             |
| 406                        | 305         | —                        | 254   | 355.6 | —     | 250.8 | 361.9 | 374.6 | 4             | 7          | 390                        | 0.8             |
| 457                        | 330         | 203.2                    | 304.8 | 406.4 | 212.7 | 301.6 | 412.7 | 425.4 | 5             | 8          | 380                        | 0.9             |
| 508                        | 381         | 228.6                    | 355.6 | 457.2 | 238.1 | 352.4 | 463.5 | 476.2 | 5             | 8          | 330                        | 1               |
| 559                        | 406         | 254                      | 406.4 | 508   | 263.5 | 403.2 | 514.3 | 527   | 5             | 8          | 320                        | 1.1             |
| 610                        | 432         | 279.4                    | 457.2 | 558.8 | 288.9 | 454   | 565.1 | 577.8 | 5             | 8          | 310                        | 1.2             |
| 660                        | 483         | 304.8                    | 508   | 609.6 | 314.3 | 504.8 | 615.9 | 628.6 | 5             | 8          | 280                        | 1.3             |
| 711                        | 508         | 330.2                    | 558.8 | 660.4 | 339.7 | 555.6 | 666.7 | 679.4 | 5             | 8          | 270                        | 1.4             |

Note: The Permissible Load and Mass each indicate when used as a pair of 2 units.

## Model number coding

### FBL35J +660L

Model number    Overall rail length (mm)

# Model FBL 35B

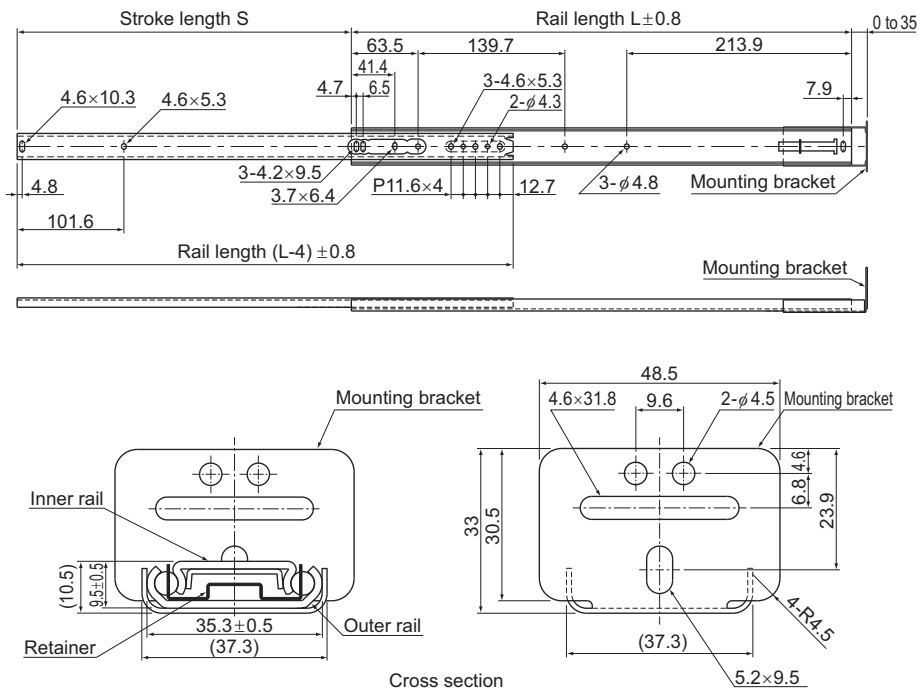

Unit: mm

| Rail length<br>L<br>(±0.8) | Stroke<br>S | Mounting hole |            | Permissible load<br>N/pair | Mass<br>kg/pair |
|----------------------------|-------------|---------------|------------|----------------------------|-----------------|
|                            |             | Inner rail    | Outer rail |                            |                 |
| 324                        | 216         | 7             | 7          | 115                        | 0.8             |
| 375                        | 267         | 7             | 7          | 105                        | 0.92            |
| 425                        | 305         | 7             | 7          | 100                        | 1               |
| 476                        | 318         | 7             | 7          | 90                         | 1.12            |
| 527                        | 368         | 7             | 7          | 83                         | 1.24            |
| 578                        | 419         | 7             | 7          | 73                         | 1.32            |
| 629                        | 445         | 7             | 7          | 66                         | 1.44            |
| 679                        | 495         | 7             | 7          | 61                         | 1.6             |

Note: The Permissible Load and Mass each indicate when used as a pair of 2 units.

## Model number coding

**FBL35B +375L**

Model number    Overall rail length (mm)

# Model FBL 27D

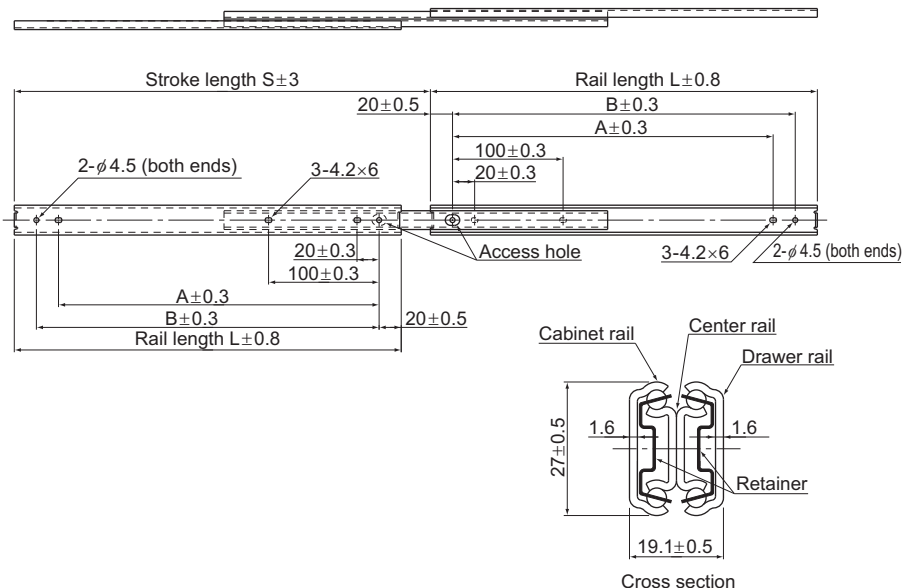

Unit: mm

| Rail length<br>L<br>(±0.8) | Stroke<br>S<br>(±3) | Mounting hole dimensions |     | Mounting hole |              | Permissible load<br>N/pair | Mass<br>kg/pair |
|----------------------------|---------------------|--------------------------|-----|---------------|--------------|----------------------------|-----------------|
|                            |                     | A                        | B   | Drawer rail   | Cabinet rail |                            |                 |
| 200                        | 229                 | 140                      | 160 | 5             | 5            | 370                        | 0.64            |
| 250                        | 276                 | 190                      | 210 | 5             | 5            | 360                        | 0.8             |
| 300                        | 327                 | 240                      | 260 | 5             | 5            | 350                        | 0.96            |
| 350                        | 376                 | 290                      | 310 | 5             | 5            | 330                        | 1.12            |
| 400                        | 426                 | 340                      | 360 | 5             | 5            | 310                        | 1.28            |
| 450                        | 475                 | 390                      | 410 | 5             | 5            | 290                        | 1.46            |
| 500                        | 524                 | 440                      | 460 | 5             | 5            | 280                        | 1.6             |

Note: The Permissible Load and Mass each indicate when used as a pair of 2 units.

## Model number coding

### FBL27D +200L

Model number    Overall rail length (mm)



# Model FBL 35N

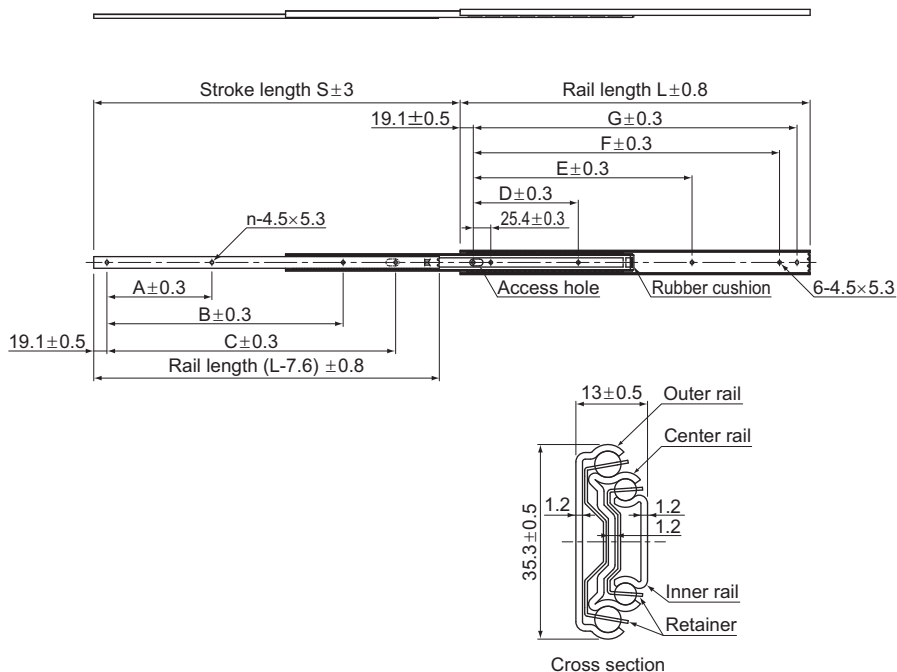

Unit: mm

| Rail length<br>L<br>(±0.8) | Stroke<br>S<br>(±3) | Mounting hole dimensions |       |       |       |       |       |       | Mounting<br>hole<br>n | Permissible<br>load<br>N/pair | Mass<br>kg/pair |
|----------------------------|---------------------|--------------------------|-------|-------|-------|-------|-------|-------|-----------------------|-------------------------------|-----------------|
|                            |                     | A                        | B     | C     | D     | E     | F     | G     |                       |                               |                 |
| 254                        | 280                 | 76.2                     | 154.9 | 180.3 | 76.2  | 139.7 | 190.5 | 215.9 | 4                     | 290                           | 0.61            |
| 305                        | 330                 | 76.2                     | 154.9 | 231.1 | 76.2  | 190.5 | 241.3 | 266.7 | 4                     | 290                           | 0.74            |
| 356                        | 381                 | 127                      | —     | 266.7 | 88.9  | 215.9 | 292.1 | 317.5 | 3                     | 280                           | 0.86            |
| 406                        | 432                 | 152.4                    | —     | 317.5 | 127   | 241.3 | 342.9 | 368.3 | 3                     | 270                           | 0.98            |
| 457                        | 483                 | 177.8                    | —     | 368.3 | 127   | 292.1 | 393.7 | 419.1 | 3                     | 250                           | 1.1             |
| 508                        | 533                 | 152.4                    | 342.9 | 419.1 | 152.4 | 317.5 | 444.5 | 469.9 | 4                     | 240                           | 1.22            |

## Model number coding

### FBL35N +508L

Model No. Overall rail length (mm)

# Model FBL 35N-P16

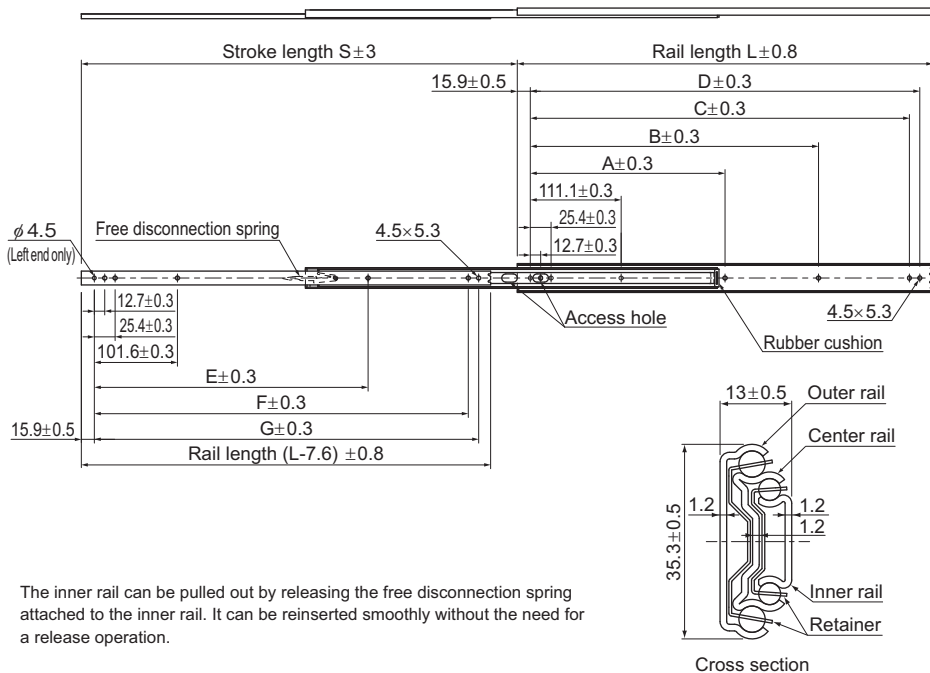

Unit: mm

| Rail length<br>L<br>(±0.8) | Stroke<br>S<br>(±3) | Mounting hole dimensions |       |       |       |       |       |       | Mounting hole |               | Permissible<br>load<br>N/pair | Mass<br>kg/pair |
|----------------------------|---------------------|--------------------------|-------|-------|-------|-------|-------|-------|---------------|---------------|-------------------------------|-----------------|
|                            |                     | A                        | B     | C     | D     | E     | F     | G     | Inner<br>rail | Outer<br>rail |                               |                 |
| 254                        | 280                 | —                        | —     | 209.5 | 222.2 | —     | 203.2 | 215.9 | 6             | 6             | 290                           | 0.61            |
| 305                        | 330                 | —                        | 149.2 | 260.3 | 273   | 233.1 | 254   | 266.7 | 7             | 7             | 290                           | 0.74            |
| 356                        | 381                 | —                        | 200   | 311.1 | 323.8 | 258.5 | 304.8 | 317.5 | 7             | 7             | 280                           | 0.86            |
| 406                        | 432                 | —                        | 250.8 | 361.9 | 374.6 | 283.9 | 355.6 | 368.3 | 7             | 7             | 270                           | 0.98            |
| 457                        | 483                 | 212.7                    | 301.6 | 412.7 | 425.4 | 309.3 | 406.4 | 419.1 | 7             | 8             | 250                           | 1.1             |
| 508                        | 533                 | 238.1                    | 352.4 | 463.5 | 476.2 | 334.7 | 457.2 | 469.9 | 7             | 8             | 240                           | 1.22            |

## Model number coding

**FBL35N-P16 +508L**

Model number

Overall rail length (mm)

# Model FBL 35G-P13

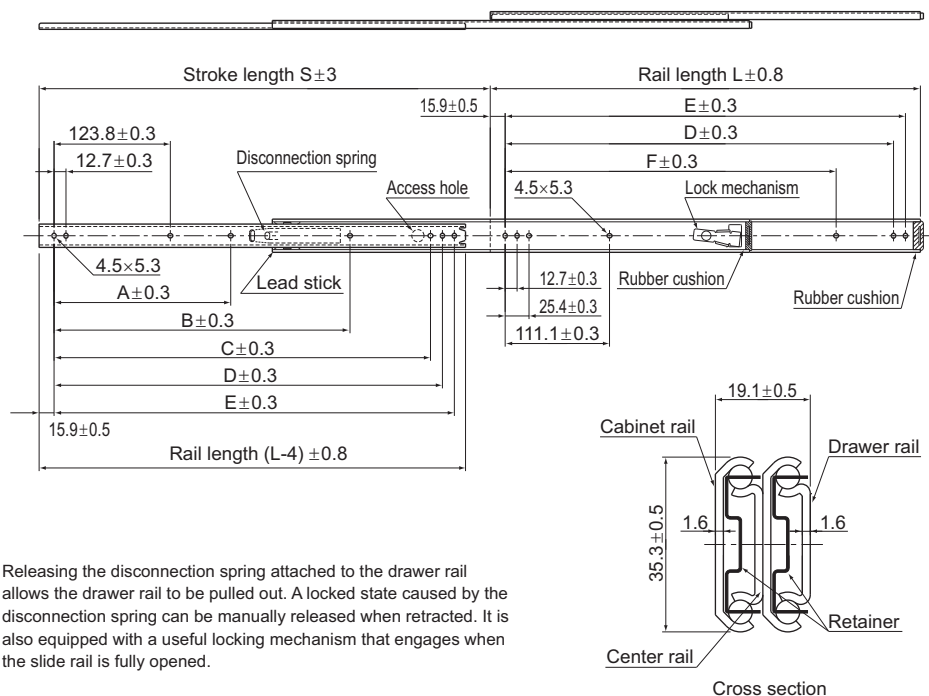

Releasing the disconnection spring attached to the drawer rail allows the drawer rail to be pulled out. A locked state caused by the disconnection spring can be manually released when retracted. It is also equipped with a useful locking mechanism that engages when the slide rail is fully opened.

Unit: mm

| Rail length<br>L<br>(±0.8) | Stroke<br>S<br>(±3) | Mounting hole dimensions |       |       |       |       |       | Mounting hole  |                 | Permissible load<br>N/pair | Mass<br>kg/pair |
|----------------------------|---------------------|--------------------------|-------|-------|-------|-------|-------|----------------|-----------------|----------------------------|-----------------|
|                            |                     | A                        | B     | C     | D     | E     | F     | Drawer<br>rail | Cabinet<br>rail |                            |                 |
| 305                        | 327                 | —                        | —     | —     | 260.3 | 273   | —     | 5              | 6               | 623                        | 1.2             |
| 356                        | 378                 | —                        | —     | 298.4 | 311.1 | 323.8 | —     | 6              | 6               | 586                        | 1.4             |
| 406                        | 429                 | —                        | —     | 349.2 | 361.9 | 374.6 | 250.8 | 6              | 7               | 555                        | 1.6             |
| 457                        | 480                 | 212.7                    | —     | 400   | 412.7 | 425.4 | 301.6 | 7              | 7               | 516                        | 1.8             |
| 508                        | 530                 | 238.1                    | 365.1 | 450.8 | 463.5 | 476.2 | 352.4 | 8              | 7               | 475                        | 2               |
| 559                        | 581                 | 263.5                    | 415.9 | 501.6 | 514.3 | 527   | 403.2 | 8              | 7               | 444                        | 2.2             |
| 610                        | 632                 | 288.9                    | 466.7 | 552.4 | 565.1 | 577.8 | 454   | 8              | 7               | 413                        | 2.4             |
| 660                        | 683                 | 314.3                    | 517.5 | 603.2 | 615.9 | 628.6 | 504.8 | 8              | 7               | 382                        | 2.6             |
| 711                        | 734                 | 339.7                    | 568.3 | 654   | 666.7 | 679.4 | 555.6 | 8              | 7               | 355                        | 2.8             |

Note: The Permissible Load and Mass each indicate when used as a pair of 2 units.

## Model number coding

**FBL35G-P13 +356L**

Model number

Overall rail length (mm)

# Model FBL 35G-P14

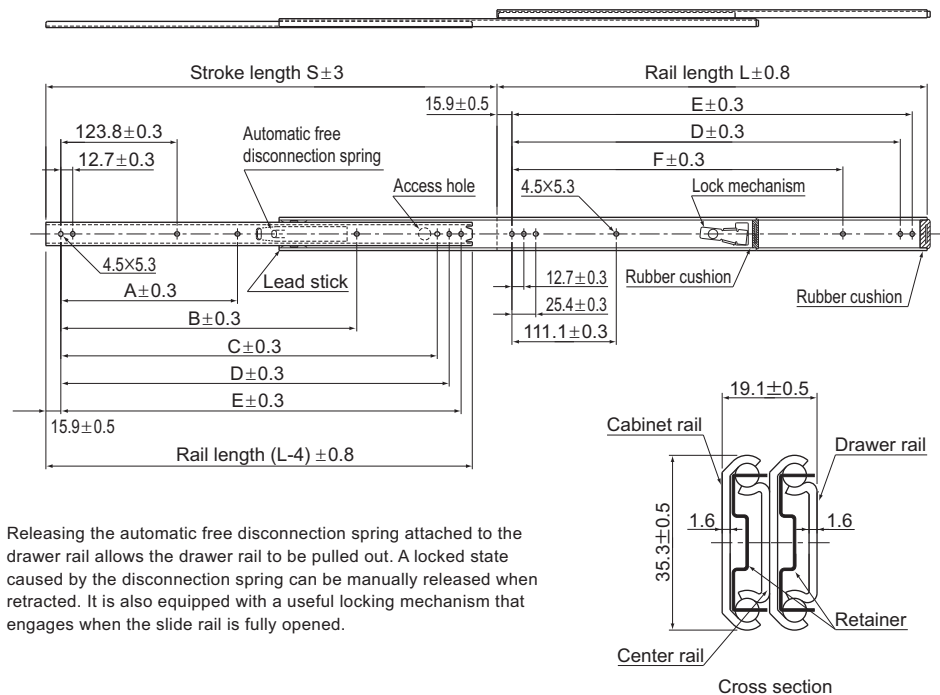

Releasing the automatic free disconnection spring attached to the drawer rail allows the drawer rail to be pulled out. A locked state caused by the disconnection spring can be manually released when retracted. It is also equipped with a useful locking mechanism that engages when the slide rail is fully opened.

Unit: mm

| Rail length<br>L<br>(±0.8) | Stroke<br>S<br>(±3) | Mounting hole dimensions |       |       |       |       |       | Mounting hole  |                 | Permissible load<br>N/pair | Mass<br>kg/pair |
|----------------------------|---------------------|--------------------------|-------|-------|-------|-------|-------|----------------|-----------------|----------------------------|-----------------|
|                            |                     | A                        | B     | C     | D     | E     | F     | Drawer<br>rail | Cabinet<br>rail |                            |                 |
| 305                        | 327                 | —                        | —     | —     | 260.3 | 273   | —     | 5              | 6               | 623                        | 1.2             |
| 356                        | 378                 | —                        | —     | 298.4 | 311.1 | 323.8 | —     | 6              | 6               | 586                        | 1.4             |
| 406                        | 429                 | —                        | —     | 349.2 | 361.9 | 374.6 | 250.8 | 6              | 7               | 555                        | 1.6             |
| 457                        | 480                 | 212.7                    | —     | 400   | 412.7 | 425.4 | 301.6 | 7              | 7               | 516                        | 1.8             |
| 508                        | 530                 | 238.1                    | 365.1 | 450.8 | 463.5 | 476.2 | 352.4 | 8              | 7               | 475                        | 2               |
| 559                        | 581                 | 263.5                    | 415.9 | 501.6 | 514.3 | 527   | 403.2 | 8              | 7               | 444                        | 2.2             |
| 610                        | 632                 | 288.9                    | 466.7 | 552.4 | 565.1 | 577.8 | 454   | 8              | 7               | 413                        | 2.4             |
| 660                        | 683                 | 314.3                    | 517.5 | 603.2 | 615.9 | 628.6 | 504.8 | 8              | 7               | 382                        | 2.6             |
| 711                        | 734                 | 339.7                    | 568.3 | 654   | 666.7 | 679.4 | 555.6 | 8              | 7               | 355                        | 2.8             |

Note: The Permissible Load and Mass each indicate when used as a pair of 2 units.

## Model number coding

**FBL35G-P14 +610L**

Model number

Overall rail length (mm)

# Model FBL 35D

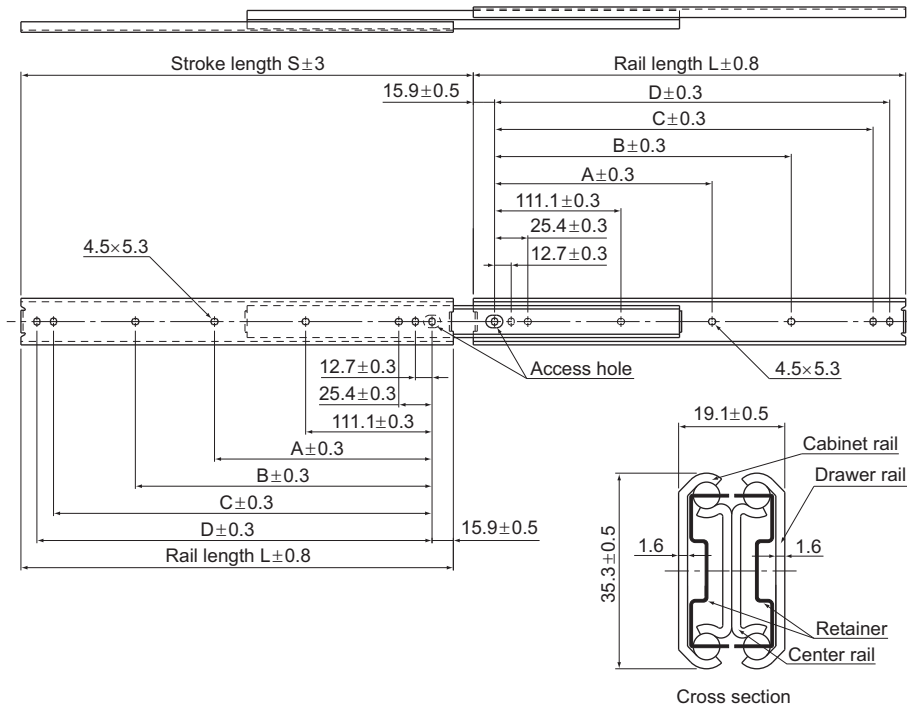

Unit: mm

| Rail length<br>L<br>(±0.8) | Stroke<br>S<br>(±3) | Mounting hole dimensions |       |       |       | Mounting hole  |                 | Permissible load<br>N/pair | Mass<br>kg/pair |
|----------------------------|---------------------|--------------------------|-------|-------|-------|----------------|-----------------|----------------------------|-----------------|
|                            |                     | A                        | B     | C     | D     | Drawer<br>rail | Cabinet<br>rail |                            |                 |
| 305                        | 327                 | —                        | 149.2 | 260.3 | 273   | 7              | 7               | 588                        | 1.28            |
| 356                        | 378                 | —                        | 200   | 311.1 | 323.8 | 7              | 7               | 578                        | 1.48            |
| 406                        | 429                 | —                        | 250.8 | 361.9 | 374.6 | 7              | 7               | 559                        | 1.72            |
| 457                        | 480                 | 212.7                    | 301.6 | 412.7 | 425.4 | 8              | 8               | 549                        | 1.96            |
| 508                        | 530                 | 238.1                    | 352.4 | 463.5 | 476.2 | 8              | 8               | 529                        | 2.12            |
| 559                        | 581                 | 263.5                    | 403.2 | 514.3 | 527   | 8              | 8               | 500                        | 2.4             |
| 610                        | 632                 | 288.9                    | 454   | 565.1 | 577.8 | 8              | 8               | 480                        | 2.56            |
| 660                        | 683                 | 314.3                    | 504.8 | 615.9 | 628.6 | 8              | 8               | 461                        | 2.8             |
| 711                        | 734                 | 339.7                    | 555.6 | 666.7 | 679.4 | 8              | 8               | 441                        | 3               |

Note: The Permissible Load and Mass each indicate when used as a pair of 2 units.

## Model number coding

**FBL35D +711L**

Model number      Overall rail length (mm)

# Model FBL 51H

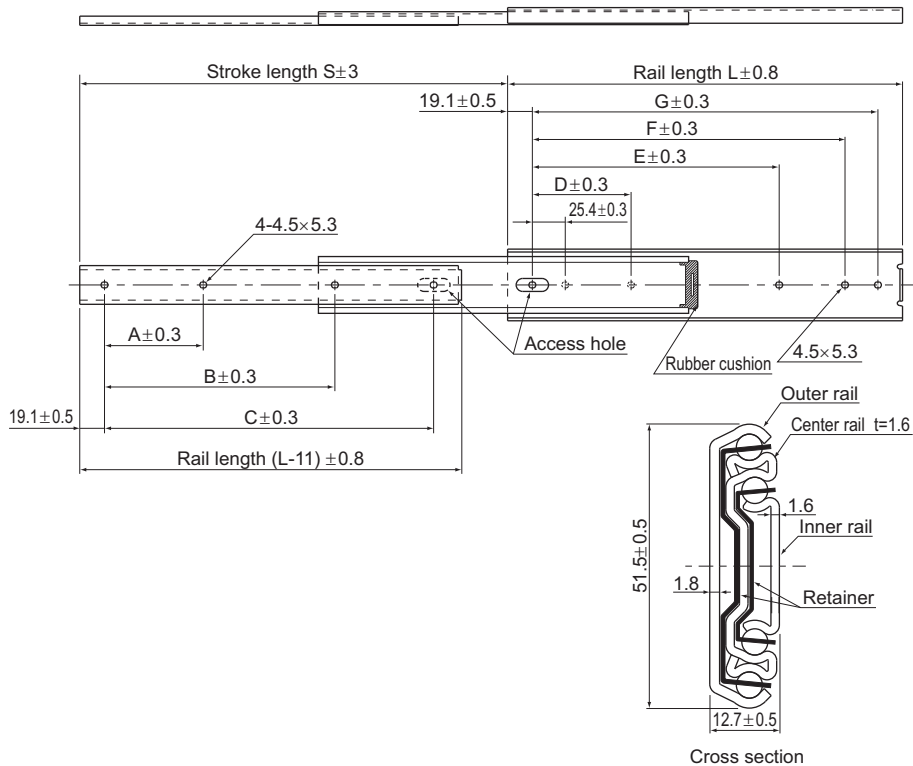

Cross section

Unit: mm

| Rail length<br>L<br>(±0.8) | Stroke<br>S<br>(±3) | Mounting hole dimensions |       |       |       |       |       |       | Mounting hole |               | Permissible load<br>N/pair | Mass<br>kg/pair |
|----------------------------|---------------------|--------------------------|-------|-------|-------|-------|-------|-------|---------------|---------------|----------------------------|-----------------|
|                            |                     | A                        | B     | C     | D     | E     | F     | G     | Inner<br>rail | Outer<br>rail |                            |                 |
| 305                        | 330                 | 76.2                     | 177.8 | 254   | 76.2  | 190.5 | 241.3 | 266.7 | 4             | 6             | 850                        | 1.46            |
| 356                        | 381                 | 101.6                    | 203.2 | 304.8 | 88.9  | 215.9 | 292.1 | 317.5 | 4             | 6             | 820                        | 1.72            |
| 406                        | 432                 | 127                      | 228.6 | 355.6 | 127   | 241.3 | 342.9 | 368.3 | 4             | 6             | 770                        | 1.89            |
| 457                        | 483                 | 127                      | 279.4 | 406.4 | 127   | 292.1 | 393.7 | 419.1 | 4             | 6             | 730                        | 2.26            |
| 508                        | 533                 | 152.4                    | 304.8 | 457.2 | 152.4 | 317.5 | 444.5 | 469.9 | 4             | 6             | 710                        | 2.52            |
| 559                        | 584                 | 177.8                    | 330.2 | 508   | 177.8 | 342.9 | 495.3 | 520.7 | 4             | 6             | 690                        | 2.72            |
| 610                        | 635                 | 177.8                    | 381   | 558.8 | 177.8 | 393.7 | 546.1 | 571.5 | 4             | 6             | 660                        | 3               |
| 660                        | 686                 | 203.2                    | 406.4 | 609.6 | 203.2 | 419.1 | 596.9 | 622.3 | 4             | 6             | 630                        | 3.25            |
| 711                        | 737                 | 228.6                    | 431.8 | 660.4 | 228.6 | 444.5 | 647.7 | 673.1 | 4             | 6             | 610                        | 3.54            |
| 762                        | 787                 | 228.6                    | 457.2 | 711.2 | 228.6 | 469.9 | 698.5 | 723.9 | 4             | 6             | 580                        | 3.86            |

Note: The Permissible Load and Mass each indicate when used as a pair of 2 units.

## Model number coding

**FBL51H +610L**

Model number      Overall rail length (mm)

# Model FBL 51H-P13

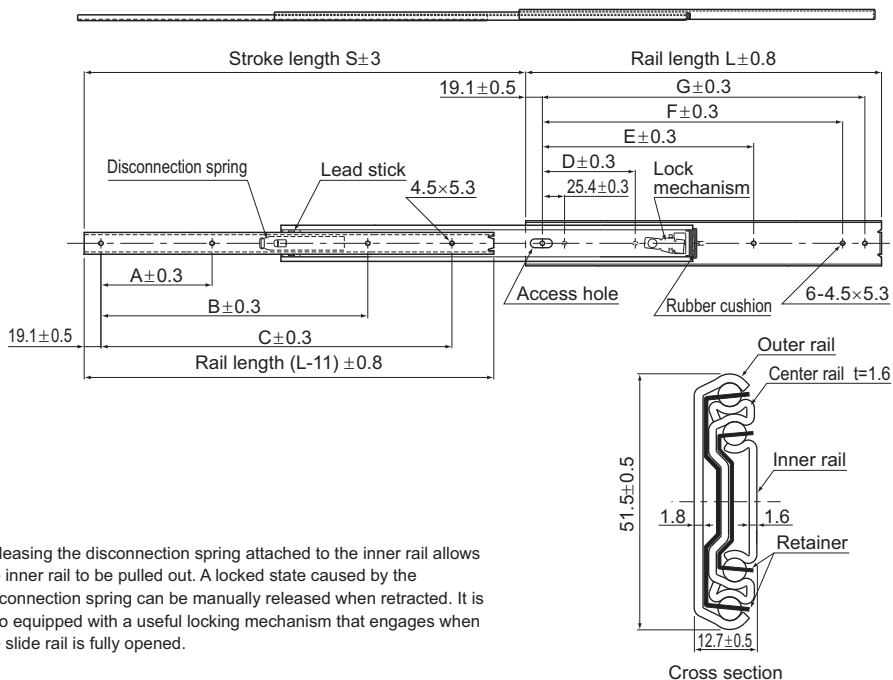

Cross section

Releasing the disconnection spring attached to the inner rail allows the inner rail to be pulled out. A locked state caused by the disconnection spring can be manually released when retracted. It is also equipped with a useful locking mechanism that engages when the slide rail is fully opened.

Unit: mm

| Rail length<br>L<br>(±0.8) | Stroke<br>S<br>(±3) | Mounting hole dimensions |       |       |       |       |       |       | Mounting hole |               | Permissible load<br>N/pair | Mass<br>kg/pair |
|----------------------------|---------------------|--------------------------|-------|-------|-------|-------|-------|-------|---------------|---------------|----------------------------|-----------------|
|                            |                     | A                        | B     | C     | D     | E     | F     | G     | Inner<br>rail | Outer<br>rail |                            |                 |
| 305                        | 330                 | 76.2                     | —     | 190.5 | 76.2  | 190.5 | 241.3 | 266.7 | 3             | 6             | 850                        | 1.46            |
| 356                        | 381                 | 101.6                    | —     | 266.7 | 88.9  | 215.9 | 292.1 | 317.5 | 3             | 6             | 820                        | 1.72            |
| 406                        | 432                 | 127                      | —     | 304.8 | 127   | 241.3 | 342.9 | 368.3 | 3             | 6             | 770                        | 1.89            |
| 457                        | 483                 | 127                      | 317.5 | 368.3 | 127   | 292.1 | 393.7 | 419.1 | 4             | 6             | 730                        | 2.26            |
| 508                        | 533                 | 152.4                    | 355.6 | 406.4 | 152.4 | 317.5 | 444.5 | 469.9 | 4             | 6             | 710                        | 2.52            |
| 559                        | 584                 | 177.8                    | 381   | 457.2 | 177.8 | 342.9 | 495.3 | 520.7 | 4             | 6             | 690                        | 2.72            |
| 610                        | 635                 | 177.8                    | 430.8 | 508   | 177.8 | 393.7 | 546.1 | 571.5 | 4             | 6             | 660                        | 3               |
| 660                        | 686                 | 203.2                    | 457.2 | 558.8 | 203.2 | 419.1 | 596.9 | 622.3 | 4             | 6             | 630                        | 3.25            |
| 711                        | 737                 | 228.6                    | 508   | 609.6 | 228.6 | 444.5 | 647.7 | 673.1 | 4             | 6             | 610                        | 3.54            |
| 762                        | 787                 | 228.6                    | 533.4 | 660.4 | 228.6 | 469.9 | 698.5 | 723.9 | 4             | 6             | 580                        | 3.86            |

Note: The Permissible Load and Mass each indicate when used as a pair of 2 units.

## Model number coding

**FBL51H-P13 +559L**

Model number

Overall rail length (mm)

# Model FBL 51H-P14

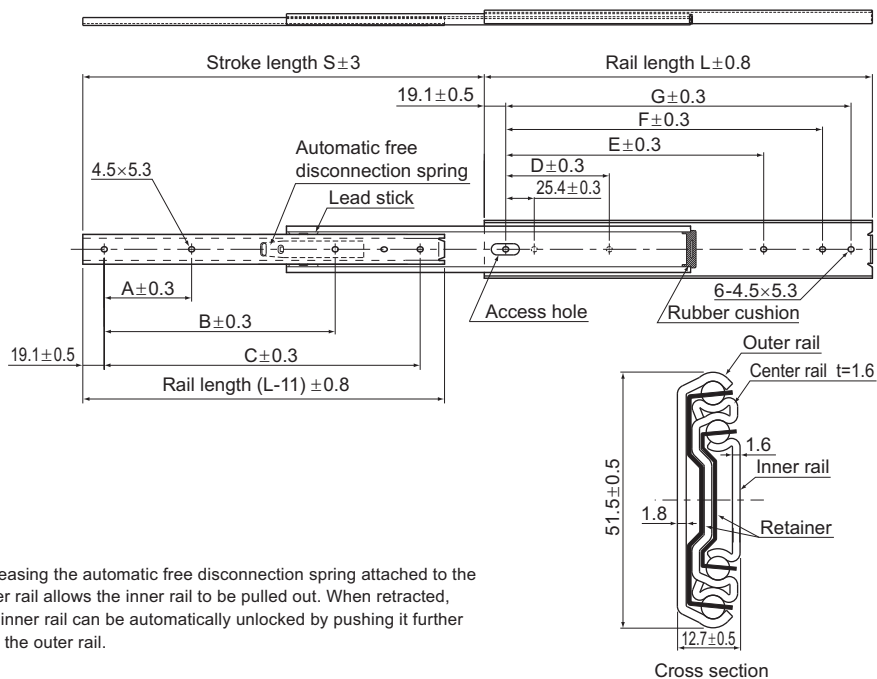

Releasing the automatic free disconnection spring attached to the inner rail allows the inner rail to be pulled out. When retracted, the inner rail can be automatically unlocked by pushing it further into the outer rail.

Unit: mm

| Rail length<br>L<br>(±0.8) | Stroke<br>S<br>(±3) | Mounting hole dimensions |       |       |       |       |       |       | Mounting hole |               | Permissible load<br>N/pair | Mass<br>kg/pair |
|----------------------------|---------------------|--------------------------|-------|-------|-------|-------|-------|-------|---------------|---------------|----------------------------|-----------------|
|                            |                     | A                        | B     | C     | D     | E     | F     | G     | Inner<br>rail | Outer<br>rail |                            |                 |
| 305                        | 330                 | 76.2                     | —     | 254   | 76.2  | 190.5 | 241.3 | 266.7 | 3             | 6             | 850                        | 1.46            |
| 356                        | 381                 | 127                      | —     | 304.8 | 88.9  | 215.9 | 292.1 | 317.5 | 3             | 6             | 820                        | 1.72            |
| 406                        | 432                 | 152.4                    | 317.5 | 355.6 | 127   | 241.3 | 342.9 | 368.3 | 4             | 6             | 770                        | 1.89            |
| 457                        | 483                 | 177.8                    | 368.3 | 406.4 | 127   | 292.1 | 393.7 | 419.1 | 4             | 6             | 730                        | 2.26            |
| 508                        | 533                 | 152.4                    | 419.1 | 457.2 | 152.4 | 317.5 | 444.5 | 469.9 | 4             | 6             | 710                        | 2.52            |
| 559                        | 584                 | 177.8                    | 469.9 | 508   | 177.8 | 342.9 | 495.3 | 520.7 | 4             | 6             | 690                        | 2.72            |
| 610                        | 635                 | 177.8                    | 520.7 | 558.8 | 177.8 | 393.7 | 546.1 | 571.5 | 4             | 6             | 660                        | 3               |
| 660                        | 686                 | 203.2                    | 571.5 | 609.6 | 203.2 | 419.1 | 596.9 | 622.3 | 4             | 6             | 630                        | 3.25            |
| 711                        | 737                 | 228.6                    | 622.3 | 660.4 | 228.6 | 444.5 | 647.7 | 673.1 | 4             | 6             | 610                        | 3.54            |
| 762                        | 787                 | 228.6                    | 673.1 | 711.2 | 228.6 | 469.9 | 698.5 | 723.9 | 4             | 6             | 580                        | 3.86            |

Note: The Permissible Load and Mass each indicate when used as a pair of 2 units.

## Model number coding

**FBL51H-P14 +305L**

Model number

Overall rail length (mm)

# Model FBL 35K

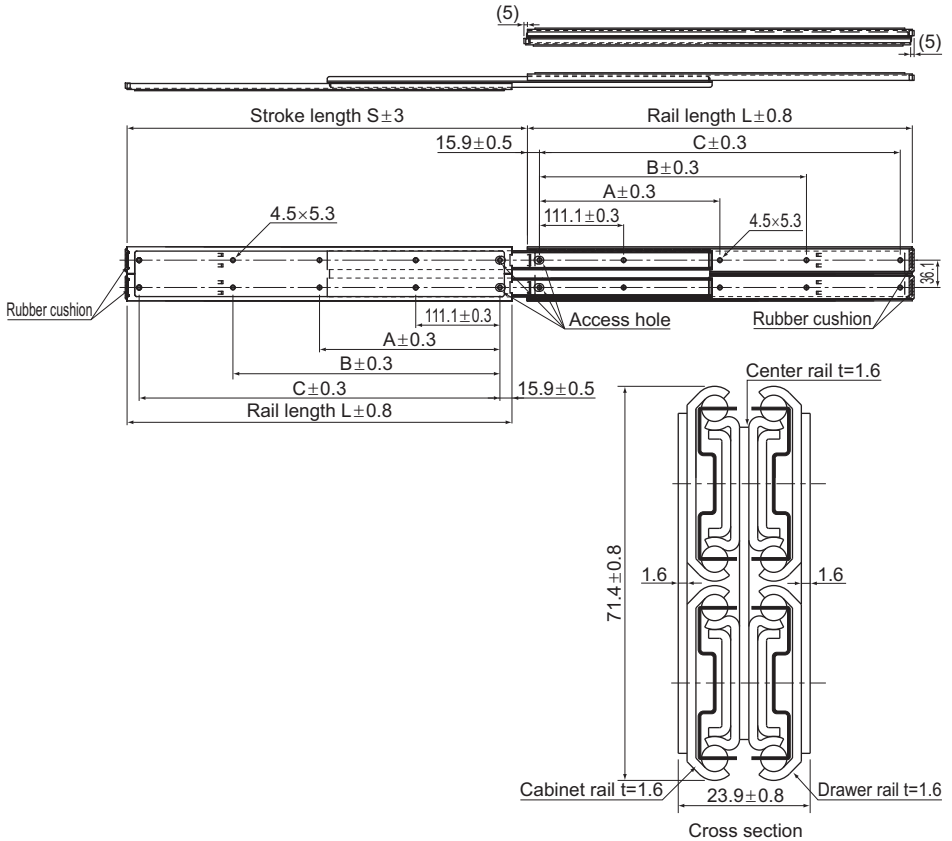

Unit: mm

| Rail length<br>$L$<br>(±0.8) | Stroke<br>$S$<br>(±3) | Mounting hole dimensions |       |       | Mounting hole  |                 | Permissible load<br>N/pair | Mass<br>kg/pair |
|------------------------------|-----------------------|--------------------------|-------|-------|----------------|-----------------|----------------------------|-----------------|
|                              |                       | A                        | B     | C     | Drawer<br>rail | Cabinet<br>rail |                            |                 |
| 305                          | 327                   | —                        | 149.2 | 273   | 4              | 4               | 2670                       | 4.04            |
| 356                          | 378                   | —                        | 200   | 323.8 | 4              | 4               | 2630                       | 4.8             |
| 406                          | 429                   | —                        | 250.8 | 374.6 | 4              | 4               | 2540                       | 5.6             |
| 457                          | 480                   | 212.7                    | 301.6 | 425.4 | 5              | 5               | 2450                       | 6.04            |
| 508                          | 530                   | 238.1                    | 352.4 | 476.2 | 5              | 5               | 2360                       | 6.92            |
| 559                          | 581                   | 263.5                    | 403.2 | 527   | 5              | 5               | 2250                       | 7.56            |
| 610                          | 632                   | 288.9                    | 454   | 577.8 | 5              | 5               | 2120                       | 8.4             |
| 660                          | 683                   | 314.3                    | 504.8 | 628.6 | 5              | 5               | 1960                       | 9               |
| 711                          | 734                   | 339.7                    | 555.6 | 679.4 | 5              | 5               | 1780                       | 9.68            |

Notes: The Permissible Load and Mass each indicate when used as a pair of 2 units.

The product has a rubber cushion. If desiring to keep the length within the rail length when storing the product, remove the rubber cushion.

## Model number coding

### FBL35K +711L

Model number Overall rail length (mm)

# Model FBL 56H

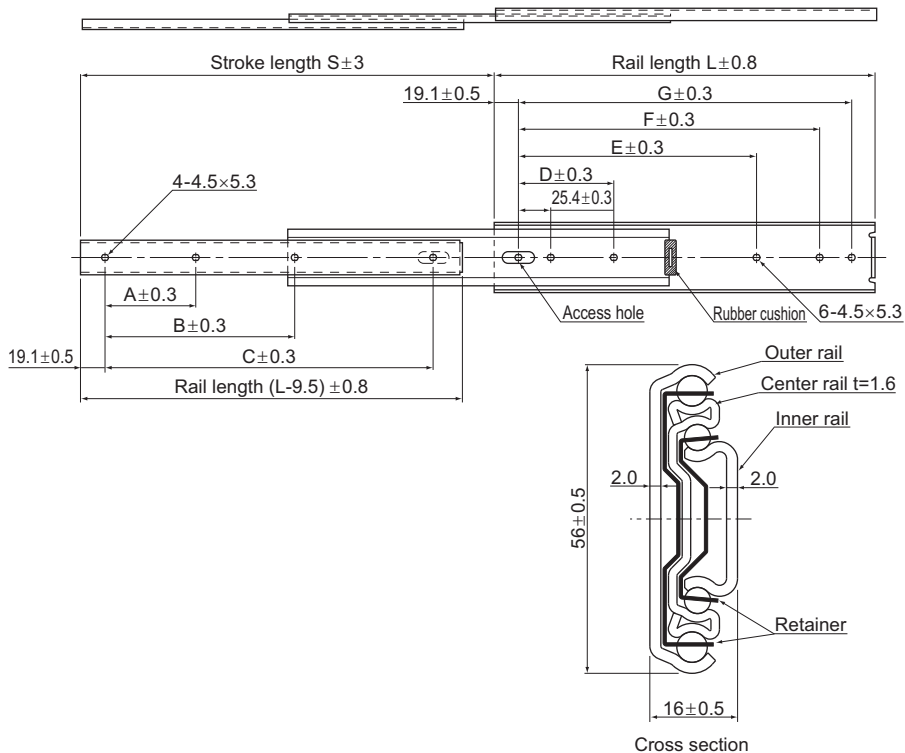

Unit: mm

| Rail length<br>L<br>( $\pm 0.8$ ) | Stroke<br>S<br>( $\pm 3$ ) | Mounting hole dimensions |       |       |       |       |       |       | Mounting hole |               | Permissible load<br>N/pair | Mass<br>kg/pair |
|-----------------------------------|----------------------------|--------------------------|-------|-------|-------|-------|-------|-------|---------------|---------------|----------------------------|-----------------|
|                                   |                            | A                        | B     | C     | D     | E     | F     | G     | Inner<br>rail | Outer<br>rail |                            |                 |
| 305                               | 330                        | 76.2                     | 177.8 | 254   | 76.2  | 190.5 | 241.3 | 266.7 | 4             | 6             | 961                        | 1.76            |
| 356                               | 381                        | 101.6                    | 203.2 | 304.8 | 88.9  | 215.9 | 292.1 | 317.5 | 4             | 6             | 951                        | 2.04            |
| 406                               | 432                        | 127                      | 228.6 | 355.6 | 127   | 241.3 | 342.9 | 368.3 | 4             | 6             | 941                        | 2.36            |
| 457                               | 483                        | 127                      | 279.4 | 406.4 | 127   | 292.1 | 393.7 | 419.1 | 4             | 6             | 922                        | 2.64            |
| 508                               | 533                        | 152.4                    | 304.8 | 457.2 | 152.4 | 317.5 | 444.5 | 469.9 | 4             | 6             | 902                        | 2.96            |
| 559                               | 584                        | 177.8                    | 330.2 | 508   | 177.8 | 342.9 | 495.3 | 520.7 | 4             | 6             | 882                        | 3.24            |
| 610                               | 635                        | 177.8                    | 381   | 558.8 | 177.8 | 393.7 | 546.1 | 571.5 | 4             | 6             | 863                        | 3.6             |
| 660                               | 686                        | 203.2                    | 406.4 | 609.6 | 203.2 | 419.1 | 596.9 | 622.3 | 4             | 6             | 843                        | 3.84            |
| 711                               | 737                        | 228.6                    | 431.8 | 660.4 | 228.6 | 444.5 | 647.7 | 673.1 | 4             | 6             | 824                        | 4.06            |
| 762                               | 787                        | 228.6                    | 457.2 | 711.2 | 228.6 | 469.9 | 698.5 | 723.9 | 4             | 6             | 784                        | 4.44            |

Note: The Permissible Load and Mass each indicate when used as a pair of 2 units.

## Model number coding

**FBL56H +406L**

Model number      Overall rail length (mm)

# Model FBL 56H-P13

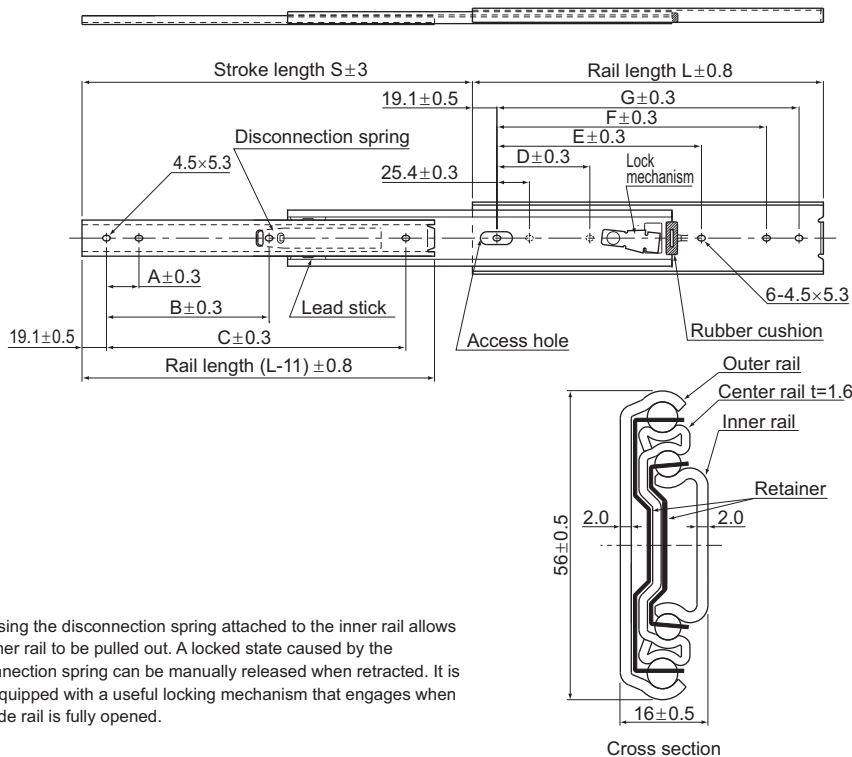

Releasing the disconnection spring attached to the inner rail allows the inner rail to be pulled out. A locked state caused by the disconnection spring can be manually released when retracted. It is also equipped with a useful locking mechanism that engages when the slide rail is fully opened.

Unit: mm

| Rail length<br>L<br>(±0.8) | Stroke<br>S<br>(±3) | Mounting hole dimensions |       |       |       |       |       |       | Mounting hole |            | Permissible load<br>N/pair | Mass<br>kg/pair |
|----------------------------|---------------------|--------------------------|-------|-------|-------|-------|-------|-------|---------------|------------|----------------------------|-----------------|
|                            |                     | A                        | B     | C     | D     | E     | F     | G     | Inner rail    | Outer rail |                            |                 |
| 305                        | 330                 | 76.2                     | —     | 254   | 76.2  | 190.5 | 241.3 | 266.7 | 3             | 6          | 961                        | 1.76            |
| 356                        | 381                 | 127                      | —     | 304.8 | 88.9  | 215.9 | 292.1 | 317.5 | 3             | 6          | 951                        | 2.04            |
| 406                        | 432                 | 152.4                    | 317.5 | 355.6 | 127   | 241.3 | 342.9 | 368.3 | 4             | 6          | 941                        | 2.36            |
| 457                        | 483                 | 177.8                    | 368.3 | 406.4 | 127   | 292.1 | 393.7 | 419.1 | 4             | 6          | 922                        | 2.64            |
| 508                        | 533                 | 152.4                    | 419.1 | 457.2 | 152.4 | 317.5 | 444.5 | 469.9 | 4             | 6          | 902                        | 2.96            |
| 559                        | 584                 | 177.8                    | 469.9 | 508   | 177.8 | 342.9 | 495.3 | 520.7 | 4             | 6          | 882                        | 3.24            |
| 610                        | 635                 | 177.8                    | 520.7 | 558.8 | 177.8 | 393.7 | 546.1 | 571.5 | 4             | 6          | 863                        | 3.6             |
| 660                        | 686                 | 203.2                    | 571.5 | 609.6 | 203.2 | 419.1 | 596.9 | 622.3 | 4             | 6          | 843                        | 3.84            |
| 711                        | 737                 | 228.6                    | 622.3 | 660.4 | 228.6 | 444.5 | 647.7 | 673.1 | 4             | 6          | 824                        | 4.06            |
| 762                        | 787                 | 228.6                    | 673.1 | 711.2 | 228.6 | 469.9 | 698.5 | 723.9 | 4             | 6          | 784                        | 4.44            |

Note: The Permissible Load and Mass each indicate when used as a pair of 2 units.

## Model number coding

**FBL56H-P13 +762L**

Model number

Overall rail length (mm)

# Model FBL 56H-P14

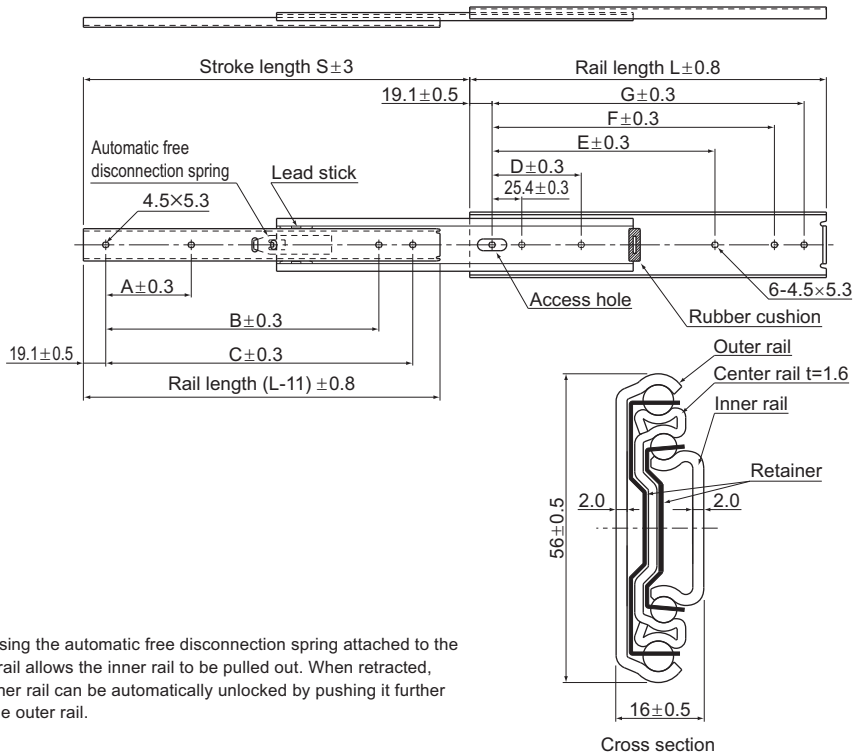

Releasing the automatic free disconnection spring attached to the inner rail allows the inner rail to be pulled out. When retracted, the inner rail can be automatically unlocked by pushing it further into the outer rail.

Cross section

Unit: mm

| Rail length<br>L<br>(±0.8) | Stroke<br>S<br>(±3) | Mounting hole dimensions |       |       |       |       |       |       | Mounting hole |               | Permissible load<br>N/pair | Mass<br>kg/pair |
|----------------------------|---------------------|--------------------------|-------|-------|-------|-------|-------|-------|---------------|---------------|----------------------------|-----------------|
|                            |                     | A                        | B     | C     | D     | E     | F     | G     | Inner<br>rail | Outer<br>rail |                            |                 |
| 305                        | 330                 | 76.2                     | —     | 254   | 76.2  | 190.5 | 241.3 | 266.7 | 3             | 6             | 961                        | 1.76            |
| 356                        | 381                 | 127                      | —     | 304.8 | 88.9  | 215.9 | 292.1 | 317.5 | 3             | 6             | 951                        | 2.04            |
| 406                        | 432                 | 152.4                    | 317.5 | 355.6 | 127   | 241.3 | 342.9 | 368.3 | 4             | 6             | 941                        | 2.36            |
| 457                        | 483                 | 177.8                    | 368.3 | 406.4 | 127   | 292.1 | 393.7 | 419.1 | 4             | 6             | 922                        | 2.64            |
| 508                        | 533                 | 152.4                    | 419.1 | 457.2 | 152.4 | 317.5 | 444.5 | 469.9 | 4             | 6             | 902                        | 2.96            |
| 559                        | 584                 | 177.8                    | 469.9 | 508   | 177.8 | 342.9 | 495.3 | 520.7 | 4             | 6             | 882                        | 3.24            |
| 610                        | 635                 | 177.8                    | 520.7 | 558.8 | 177.8 | 393.7 | 546.1 | 571.5 | 4             | 6             | 863                        | 3.6             |
| 660                        | 686                 | 203.2                    | 571.5 | 609.6 | 203.2 | 419.1 | 596.9 | 622.3 | 4             | 6             | 843                        | 3.84            |
| 711                        | 737                 | 228.6                    | 622.3 | 660.4 | 228.6 | 444.5 | 647.7 | 673.1 | 4             | 6             | 824                        | 4.06            |
| 762                        | 787                 | 228.6                    | 673.1 | 711.2 | 228.6 | 469.9 | 698.5 | 723.9 | 4             | 6             | 784                        | 4.44            |

Note: The Permissible Load and Mass each indicate when used as a pair of 2 units.

## Model number coding

**FBL56H-P14 +457L**

Model number

Overall rail length (mm)

# Model FBL 35F

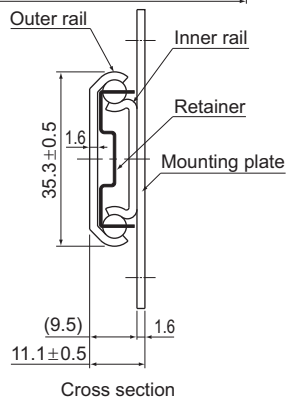
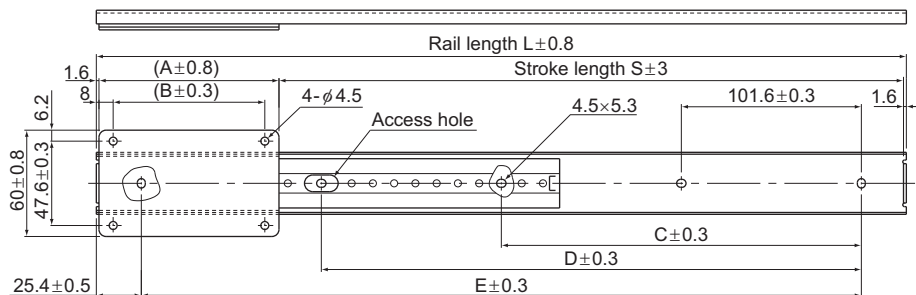

Cross section

Unit: mm

| Rail length L (±0.8)<br>mm | Mounting plate Model No. |      |      |      |      |      |
|----------------------------|--------------------------|------|------|------|------|------|
|                            | #3                       | #4   | #5   | #6   | #7   | #8   |
| 305                        | 0.6                      | 0.67 | 0.74 | 0.81 | —    | —    |
| 356                        | 0.66                     | 0.73 | 0.8  | 0.87 | 0.94 | 1.01 |
| 406                        | 0.73                     | 0.8  | 0.87 | 0.94 | 1.01 | 1.08 |
| 457                        | 0.8                      | 0.87 | 0.94 | 1.01 | 1.08 | 1.15 |
| 508                        | 0.86                     | 0.93 | 1    | 1.07 | 1.14 | 1.21 |
| 559                        | 0.93                     | 1    | 1.07 | 1.14 | 1.21 | 1.28 |
| 610                        | 1                        | 1.07 | 1.14 | 1.21 | 1.28 | 1.35 |
| 660                        | 1.06                     | 1.13 | 1.2  | 1.27 | 1.34 | 1.41 |
| 711                        | 1.13                     | 1.2  | 1.27 | 1.34 | 1.41 | 1.48 |
| 762                        | 1.2                      | 1.27 | 1.34 | 1.41 | 1.48 | 1.55 |

Mass Unit: kg/pair

| Mounting plate                                    | Model No.      | #3                                | #4    | #5    | #6    | #7    | #8    | Dimension of the outer rail mounting hole (±0.3) |       |       |
|---|----------------|-----------------------------------|-------|-------|-------|-------|-------|--|-------|-------|
|   | Length (A±0.8) | 76.2                              | 101.6 | 127   | 152.4 | 177.8 | 203.2 | C  | D     | E     |
| Rail length L (±0.8)                              |                | Stroke length S (±3) <sup>1</sup> |       |       |       |       |       | C  | D     | E     |
| 305   |                | 225.4                             | 200   | 174.6 | 149.2 | —     | —     | —  | 152.4 | 254   |
| 356   |                | 276.2                             | 250.8 | 225.4 | 200   | 174.6 | 149.2 | —  | 203.2 | 304.8 |
| 406   |                | 327                               | 301.6 | 276.2 | 250.8 | 225.4 | 200   | —  | 254   | 355.6 |
| 457   |                | 377.8                             | 352.4 | 327   | 301.6 | 276.2 | 250.8 | 203.2  | 304.8 | 406.4 |
| 508   |                | 428.6                             | 403.2 | 377.8 | 352.4 | 327   | 301.6 | 228.6  | 355.6 | 457.2 |
| 559   |                | 479.4                             | 454   | 428.6 | 403.2 | 377.8 | 352.4 | 254  | 406.4 | 508   |
| 610   |                | 530.2                             | 504.8 | 479.4 | 454   | 428.6 | 403.2 | 279.4  | 457.2 | 558.8 |
| 660   |                | 581                               | 555.6 | 530.2 | 504.8 | 479.4 | 454   | 304.8  | 508   | 609.6 |
| 711   |                | 631.8                             | 606.4 | 581   | 555.6 | 530.2 | 504.8 | 330.2  | 558.8 | 660.4 |
| 762   |                | 682.6                             | 657.2 | 631.8 | 606.4 | 581   | 555.6 | 355.6  | 609.6 | 711.2 |
| Pitch of the mounting plate mounting hole (B±0.3) |                | 60.2                              | 85.6  | 111   | 136.4 | 161.8 | 187.2 | —  | —     | —     |
| Permissible load (N/pair)                         |                | 294                               | 392   | 490   | 588   | 686   | 784   | —  | —     | —     |

<sup>1</sup> The stroke length varies with the combination with the mounting plate above.  
Note: The Permissible Load and Mass each indicate when used as a pair of 2 units.

## Model number coding

**FBL35F +356L #5**

Model number

Model number of mounting plate

Overall rail length (mm)

# Model E36RS

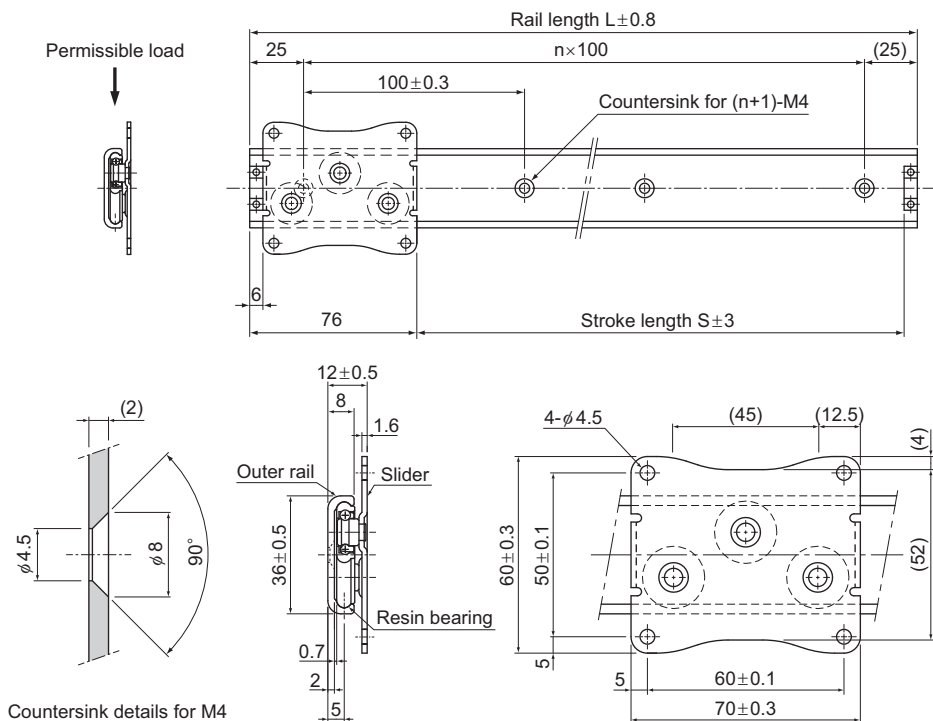

Countersink details for M4

Unit: mm

| Rail length<br>L ( $\pm 0.8$ ) | Stroke length<br>S ( $\pm 3$ ) | n | Mounting hole<br>n+1 | Permissible load <sup>1</sup><br>N | Mass<br>g |
|--------------------------------|--------------------------------|---|----------------------|------------------------------------|-----------|
| 150                            | 68                             | 1 | 2                    | 40                                 | 104       |
| 250                            | 168                            | 2 | 3                    | 40                                 | 130       |
| 350                            | 268                            | 3 | 4                    | 40                                 | 156       |
| 450                            | 368                            | 4 | 5                    | 40                                 | 182       |
| 550                            | 468                            | 5 | 6                    | 40                                 | 207       |
| 650                            | 568                            | 6 | 7                    | 40                                 | 233       |
| 750                            | 668                            | 7 | 8                    | 40                                 | 259       |

<sup>1</sup> Model E36RS differs from other slide rails by assuming use with a single rail. Therefore, the value is per single rail for permissible load.

## Model number coding

**E36RS +550L**

Model number Overall rail length (mm)

# Model E15

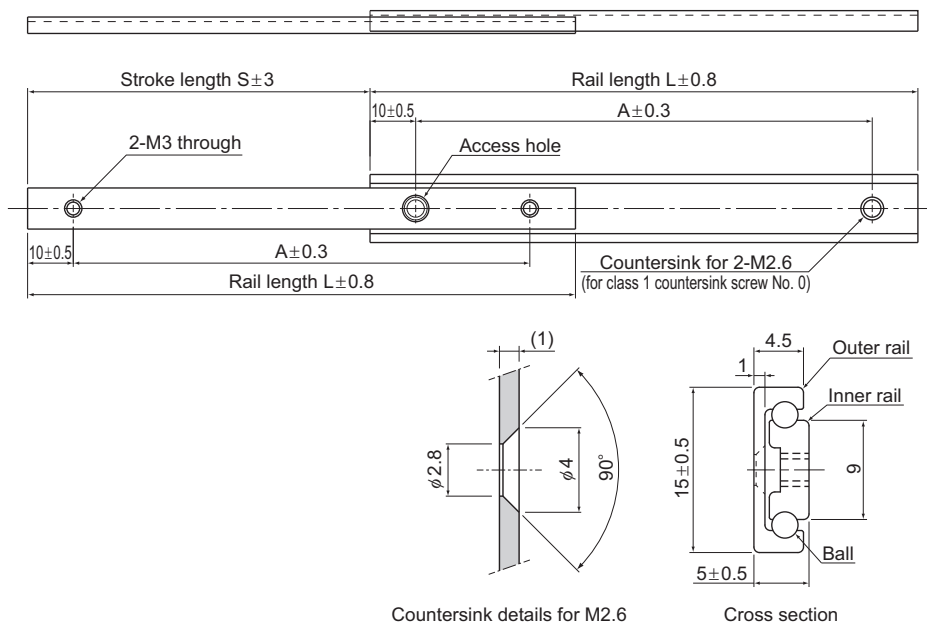

Countersink details for M2.6

Cross section

Unit: mm

| Rail length<br>L ( $\pm 0.8$ ) | Stroke<br>S ( $\pm 3$ ) | Mounting hole dimensions<br>A $\pm 0.3$ | Permissible load<br>N/pair | Mass<br>[g/pair] |
|--------------------------------|-------------------------|---|----------------------------|------------------|
| 50                             | 20                      | 30                                      | 5                          | 15               |
| 80                             | 45                      | 60                                      | 8                          | 24               |
| 100                            | 60                      | 80                                      | 10                         | 30               |
| 120                            | 75                      | 100                                     | 10                         | 36               |

Note: The Permissible Load and Mass each indicate when used as a pair of 2 units.

## Model number coding

**E15 +100L**

Model number    Overall rail length (mm)

# Model E20

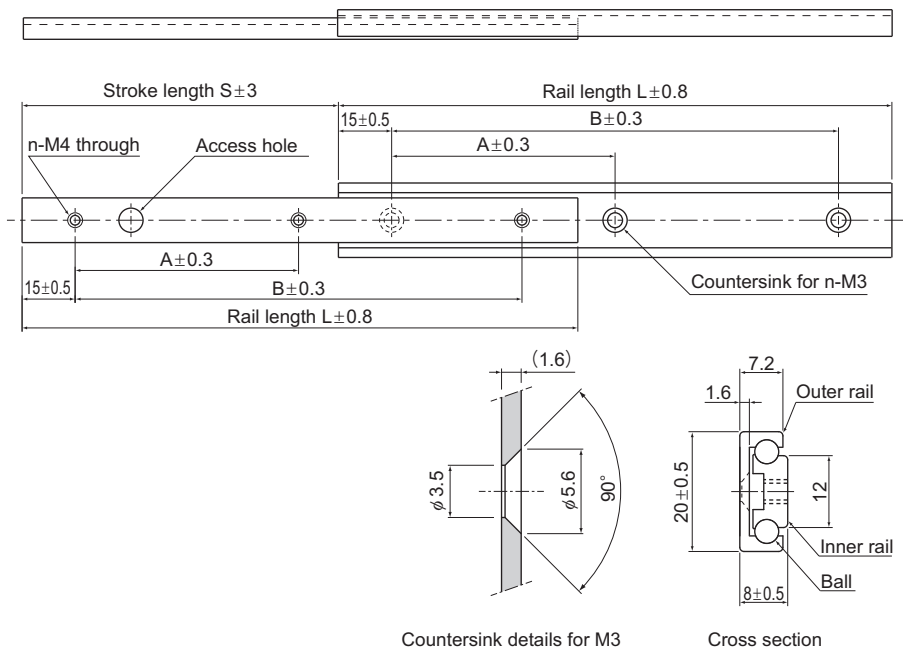

Countersink details for M3

Cross section

Unit: mm

| Rail length<br>L ( $\pm 0.8$ ) | Stroke<br>S ( $\pm 3$ ) | Mounting hole dimensions |             |         | Permissible load<br>N/pair | Mass<br>[g/pair] |
|--------------------------------|-------------------------|--------------------------|-------------|---------|----------------------------|------------------|
|                                |                         | A $\pm 0.3$              | B $\pm 0.3$ | n (pcs) |                            |                  |
| 80                             | 45                      | 50                       | —           | 2       | 20                         | 50               |
| 100                            | 60                      | 70                       | —           | 2       | 30                         | 62               |
| 150                            | 85                      | 60                       | 120         | 3       | 80                         | 98               |
| 200                            | 120                     | 85                       | 170         | 3       | 140                        | 131              |
| 300                            | 180                     | 135                      | 270         | 3       | 145                        | 197              |

Note: The Permissible Load and Mass each indicate when used as a pair of 2 units.

## Model number coding

**E20 +150L**

Model number    Overall rail length (mm)

# Model D20

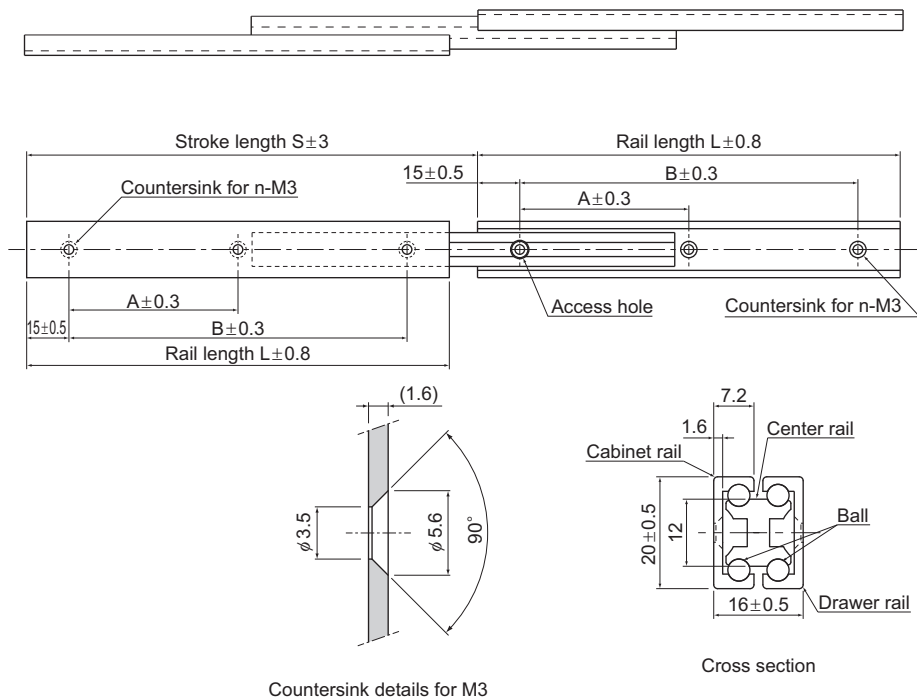

Unit: mm

| Rail length<br>$L (\pm 0.8)$ | Stroke<br>$S (\pm 3)$ | Mounting hole dimensions |         |         | Permissible load<br>N/pair | Mass<br>[g/pair] |
|------------------------------|-----------------------|--------------------------|---------|---------|----------------------------|------------------|
|                              |                       | A ± 0.3                  | B ± 0.3 | n (pcs) |                            |                  |
| 80                           | 80                    | 50                       | —       | 2       | 20                         | 94               |
| 100                          | 100                   | 70                       | —       | 2       | 30                         | 118              |
| 150                          | 160                   | 60                       | 120     | 3       | 80                         | 179              |
| 200                          | 223                   | 85                       | 170     | 3       | 140                        | 241              |
| 300                          | 345                   | 135                      | 270     | 3       | 145                        | 364              |

Note: The Permissible Load and Mass each indicate when used as a pair of 2 units.

## Model number coding

### D20 +300L

Model number Overall rail length (mm)

## Point of Design

## Slide Rail

### [Permissible Load and Mounting Orientation]

For use other than with the mounting orientation shown in Fig.1, contact THK.

The permissible load of the Slide Rail indicates the load in the direction  $P_a$  that two rails can receive in the middle of the inner rail length at the maximum stroke.

The mounting orientation shown in Fig.2 is applicable to model FBL35B only.

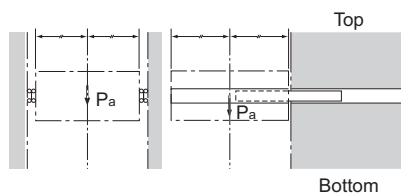

Fig.1

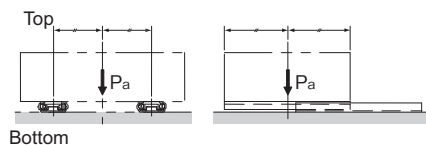

Fig.2

The mounting orientation of Fig.3 is applicable to model FBL35F.

The mounting orientation of Fig.4 is applicable to model E36RS.

Unlike other slide rails, model E36RS is used in a single rail configuration. Therefore, the load must be centered on the ball and the cage center line.

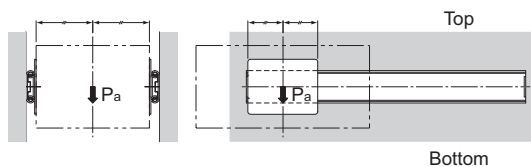

Fig.3

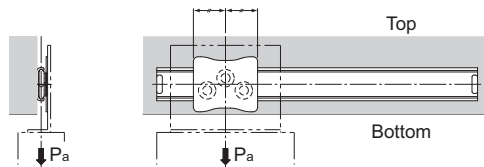

Fig.4

#### [Surface Treatment]

The surface of the Slide Rail is electro-galvanized (treated with trivalent chromate) as standard.

The aluminum slide rail of models E and D is white alumite-treated as standard. The slider of model E36RS is electro-galvanized (trivalent chromate treatment) and the rail is white alumite-treated as standard. For other surface treatments, contact THK.

---

## Model Number Coding

---

Model number configurations differ depending on the model features. Refer to the corresponding sample model number configuration.

### [Single slide/Double slide]

- Models FBL 27S, FBL 27S-P14, FBL 35S, FBL 35S-P13, FBL 35S-P14, FBL 35M, FBL 35J, FBL 35B, FBL 27D, FBL 35N, FBL 35N-P16, FBL 35G-P13, FBL 35G-P14, FBL 35D, FBL 51H, FBL 51H-P13, FBL 51H-P14, FBL 35K, FBL 56H, FBL 56H-P13 and FBL 56H-P14
- 

**FBL27S +300L**

Model No.      Overall rail length (in mm)

---

### [Linear Type Slides]

- Model FBL35F
- 

**FBL35F +356L #5**

Model No.      Overall rail length (in mm)      Model number of mounting plate

---

### [Linear Slide Wheel-type]

- Model E36RS
- 

**E36RS +550L**

Model number      Overall rail length (mm)

---

### [Aluminum Alloy Slide Rail]

- Models E15, E20 and D20
- 

**E15 +100L**

Model No.      Overall rail length (in mm)

---

## Precautions on Use

## Slide Rail

### [Handling]

- (1) Tilting a Slide Rail may cause it to fall by its own weight.
- (2) Do not disassemble the parts. This will result in loss of functionality.
- (3) Take care not to drop or strike the Slide Rail. Doing so may cause injury or damage. Giving an impact to it could also cause damage to its function even if the product looks intact.
- (4) When handling the product, wear protective gloves, safety shoes, etc., as necessary to ensure safety.

### [Precautions on Use]

- (1) When mounting the Slide Rail, use care to always keep both rails in parallel.
- (2) Prevent foreign material, such as cutting chips or coolant, from entering the product. Failure to do so may cause damage.
- (3) If the product is used in an environment where cutting chips, coolant, corrosive solvents, water, etc., may enter the product, use bellows, covers, etc., to prevent them from entering the product.
- (4) If foreign material such as cutting chips adheres to the product, replenish the lubricant after cleaning the product.
- (5) Avoid using the product at other than normal temperature, or using it in harsh conditions such as intensive reciprocations that generate frictional heat and environments with water or dust.
- (6) The durability of the Slide Rail varies depending on factors such as the drawing dimension, travel distance, mounting conditions and environment in addition to operating frequency. Take these factors into account when making a selection.
- (7) Note that the cage creep may occur if the slide rail is mounted vertically, subject to machine vibrations, etc. To correct the cage creep, fully open and fully close the slide rail. During this process, the motion will be less smooth than usual. If cage creep is inevitable, we recommend using Slide Packs, LM Guides, etc., which are infinite stroke linear motion systems.
- (8) If you replace an old slider or outer rail of your E36RS with a new one, the clearance and sliding resistance may substantially increase.
- (9) Do not use the supplied stopper as a mechanical stopper. This may damage the stopper due to impact.
- (10) Do not use undue force when fitting parts (pin, key, etc.) to the product. This may generate pressure marks on the raceway, leading to loss of functionality.
- (11) Insufficient rigidity or accuracy of mounting members causes the bearing load to concentrate on one point and the bearing performance will drop significantly. Accordingly, give sufficient consideration to the rigidity/accuracy of the housing and base and strength of the fixing bolts.

### [Lubrication]

- (1) Lithium soap-based grease No. 2 is applied to the slide rail. Do not mix different lubricants. Even greases containing the same type of thickening agent may, if mixed, interact adversely due to disparate additives or other ingredients.
- (2) The consistency of grease changes according to the temperature. Take note that the slide resistance of the Slide Rail also changes as the consistency of grease changes.
- (3) After lubrication, the slide resistance of the Slide Rail may increase due to the agitation resistance of grease. Be sure to let the grease spread fully before use.
- (4) Excess grease may scatter immediately after lubrication, so wipe off scattered grease as necessary.
- (5) The properties of grease deteriorate and its lubrication performance drops over time, so grease must be checked and added properly according to the use frequency of the machine.
- (6) The greasing interval varies depending on the use condition and service environment. Set the final lubrication interval/amount based on the actual machine.

**[Storage]**

When storing the Slide Rail, enclose it in a package designated by THK and store it in a room in a horizontal orientation while avoiding high temperature, low temperature and high humidity.

After the product has been in storage for an extended period of time, lubricant inside may have deteriorated, so add new lubricant before use.

**[Disposal]**

Dispose of the product properly as industrial waste.





# Slide Rail

THK General Catalog

## B Support Book

|   |        |
|---|--------|
| <b>Features and Types</b> .....           | A13-2  |
| Features of the Slide Rail .....          | A13-2  |
| • Structure and Features .....            | A13-2  |
| Slide Rail Types .....                    | A13-3  |
| • Types and Features .....                | A13-3  |
| Classification Table for Slide Rails..... | A13-12 |
| <b>Mounting Procedure</b> .....           | A13-14 |
| Mounting the Slide Rail.....              | A13-14 |
| <b>Model No.</b> .....                    | A13-17 |
| • Model Number Coding .....               | A13-17 |
| <b>Precautions on Use</b> .....           | A13-18 |

## A Product Descriptions (Separate)

|   |        |
|---|--------|
| <b>Features and Types</b> .....           | A13-2  |
| Features of the Slide Rail .....          | A13-2  |
| • Structure and Features .....            | A13-2  |
| Slide Rail Types .....                    | A13-3  |
| • Types and Features .....                | A13-3  |
| Classification Table for Slide Rails..... | A13-12 |

### Dimensional Drawing, Dimensional Table

|                         |        |
|-------------------------|--------|
| Model FBL 27S .....     | A13-14 |
| Model FBL 27S-P14 ..... | A13-15 |
| Model FBL 35S .....     | A13-16 |
| Model FBL 35S-P13 ..... | A13-17 |
| Model FBL 35S-P14 ..... | A13-18 |
| Model FBL 35M .....     | A13-19 |
| Model FBL 35J .....     | A13-20 |
| Model FBL 35B .....     | A13-21 |
| Model FBL 27D .....     | A13-22 |
| Model FBL 35N .....     | A13-24 |
| Model FBL 35N-P16 ..... | A13-25 |
| Model FBL 35G-P13 ..... | A13-26 |
| Model FBL 35G-P14 ..... | A13-27 |
| Model FBL 35D .....     | A13-28 |
| Model FBL 51H .....     | A13-29 |
| Model FBL 51H-P13 ..... | A13-30 |
| Model FBL 51H-P14 ..... | A13-31 |
| Model FBL 35K .....     | A13-32 |
| Model FBL 56H .....     | A13-33 |
| Model FBL 56H-P13 ..... | A13-34 |
| Model FBL 56H-P14 ..... | A13-35 |
| Model FBL 35F .....     | A13-36 |
| Model E36RS .....       | A13-37 |
| Model E15 .....         | A13-38 |
| Model E20 .....         | A13-39 |
| Model D20 .....         | A13-40 |

|                              |        |
|------------------------------|--------|
| <b>Point of Design</b> ..... | A13-41 |
|------------------------------|--------|

|                             |        |
|-----------------------------|--------|
| <b>Model No.</b> .....      | A13-43 |
| • Model Number Coding ..... | A13-43 |

|                                 |        |
|---------------------------------|--------|
| <b>Precautions on Use</b> ..... | A13-44 |
|---------------------------------|--------|

## Features of the Slide Rail

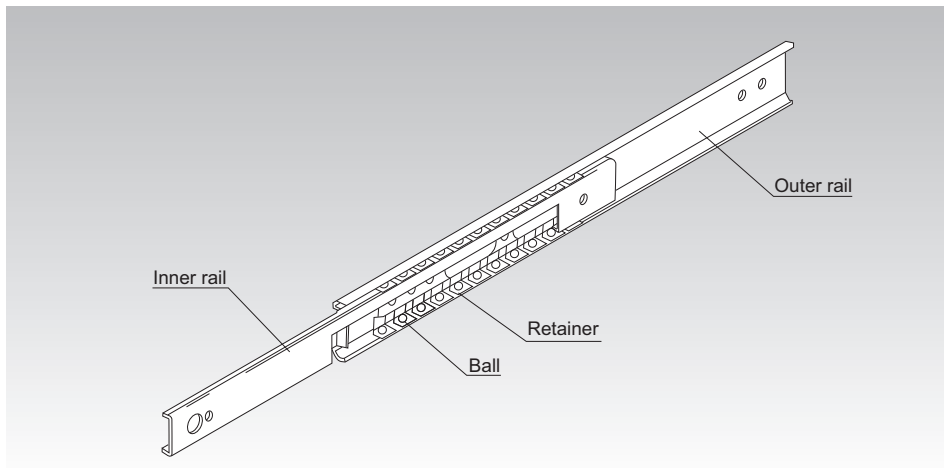

Fig.1 Structure of Slide Rail Model FBL

### Structure and Features

Slide rails are low-price finite linear guides made out of precision roll-formed steel plates. They are suitable as linear motion guides for various applications because they are thin, compact, and easy to mount. Slide rails can be used in a wide range of applications such as photocopiers, measuring instruments, telecommunications equipment, medical equipment, automatic vending machines, and various types of office equipment.

The Model FBL slide rail has two rows of ball bearings placed between an inner rail and an outer rail that have been roll-formed out of steel plates. The ball bearings are evenly spaced by a precisely press-molded retainer, eliminating friction between the bearings and achieving a smooth sliding mechanism.

#### [Allows Easy Installation]

Simple to mount on the mounting surface. Since retainers hold the bearings, they do not fall out even if the inner rail is removed.

#### [Thin and Compact]

The thin cross section of the Model FBL slide rail means it can be installed in small spaces, and it is suitable for places where space saving is required.

#### [High Corrosion Resistance]

The Model FBL slide rail is treated with zinc plating, and models E and D are treated with a white anodized aluminum coating, making them highly corrosion-resistant.

# Slide Rail Types

## Types and Features

[Single Slides for Light Load]

### Model FBL 27S

The most compact slide rail.

Specification Table⇒ **A** 13-14

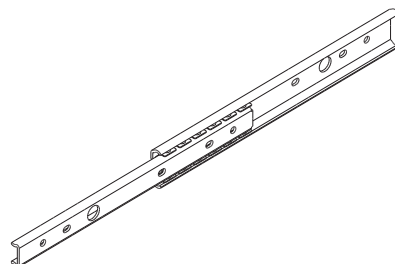

Model FBL 27S

### Model FBL 27S-P14

The Model FBL 27S features a removable inner rail. When retracted, the inner rail can be automatically unlocked by pushing it further into the outer rail.

Specification Table⇒ **A** 13-15

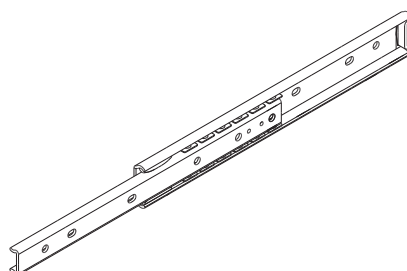

Model FBL 27S-P14

### Model FBL 35S

A single slide type of slide rail with the most fundamental shape.

Specification Table⇒ **A** 13-16

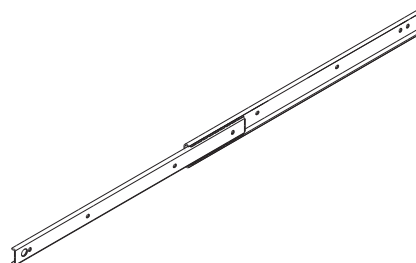

Model FBL 35S

## Model FBL 35S-P13

The Model FBL 35S features a removable inner rail. When retracted, it can be unlocked manually.

Specification Table⇒ **A13-17**

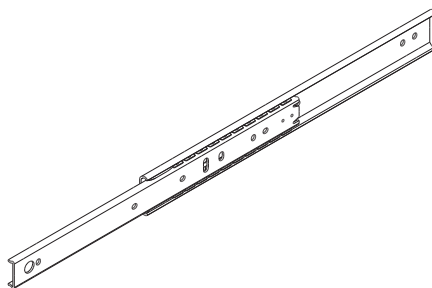

Model FBL 35S-P13

## Model FBL 35S-P14

The Model FBL 35S features a removable inner rail. When retracted, the inner rail can be automatically unlocked by pushing it further into the outer rail.

Specification Table⇒ **A13-18**

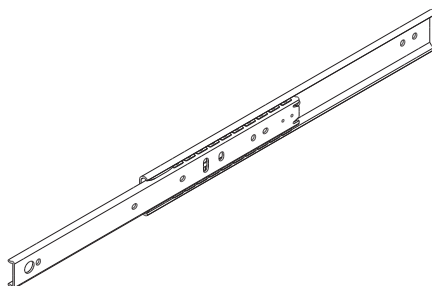

Model FBL 35S-P14

## Model FBL 35M

The Model FBL 35S features a removable inner rail. The slide rail is designed to stop by frictional resistance when it is fully opened. Remove the inner rail by applying more force. (Includes a brake stop)

Specification Table⇒ **A13-19**

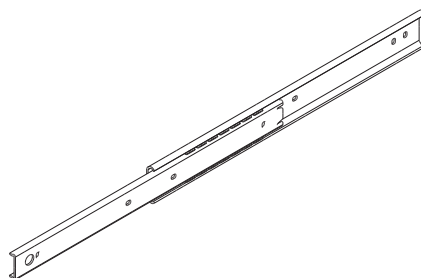

Model FBL 35M

## Features and Types

### Slide Rail Types

#### Model FBL 35J

The Model FBL 35M with additional lead ball that serves as a guide when the inner rail is inserted.

Specification Table⇒ **A** 13-20

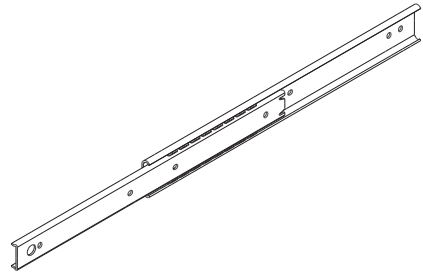

Model FBL 35J

#### Model FBL 35B

The Model FBL 35M with additional mounting bracket.

Specification Table⇒ **A** 13-21

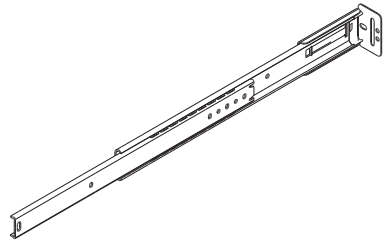

Model FBL 35B

### [Double Slides for Light Load]

## Model FBL 27D

A double slide with an additional Model FBL 27S attached on the rear side of the inner rail. Widely used in many types of OA equipment.

Specification Table⇒ **A13-22**

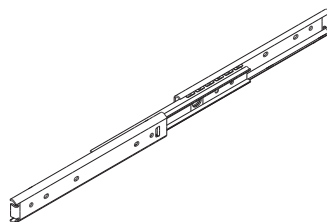

Model FBL 27D

## Model FBL 35N

This is a three-rail double slide that allows a long stroke in a small space.

This product uses a plate thickness of 1.2 mm and a light-load double slide rail to achieve weight reduction.

Specification Table⇒ **A13-24**



Model FBL 35N

## Model FBL 35N-P16

This is a three-rail double slide that allows a long stroke in a small space. It uses a plate thickness of 1.2 mm and a light-load double slide rail to achieve weight reduction. The inner rail can be pulled out, and it can be reinserted smoothly without the need for a release operation.

Specification Table⇒ **A13-25**

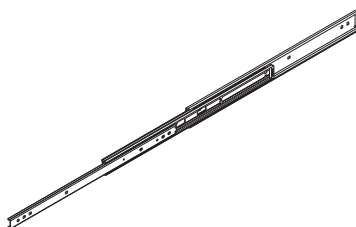

Model FBL 35N-P16

## Features and Types

### Slide Rail Types

#### [Double Slides for Medium Load]

### Model FBL 35G-P13

A double slide with an additional Model FBL 35S attached on the front side. The drawer rail can be pulled out, and it can be manually unlocked when retracted. It is also equipped with a useful locking mechanism that engages when the slide rail is fully opened.

Specification Table⇒ **A** 13-26

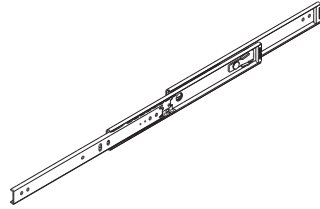

Model FBL 35G-P13

### Model FBL 35G-P14

A double slide with an additional Model FBL 35S attached on the front side. The drawer rail can be pulled out, and it can be automatically unlocked by pushing it further into the outer rail. It is also equipped with a useful locking mechanism that engages when the slide rail is fully opened.

Specification Table⇒ **A** 13-27

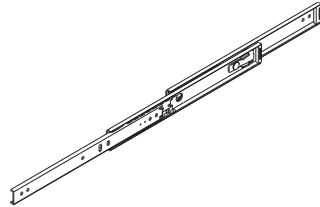

Model FBL 35G-P14

### Model FBL 35D

A double slide with an additional Model FBL 35S attached on the rear side of the inner rail. Widely used in a number of different industries.

Specification Table⇒ **A** 13-28

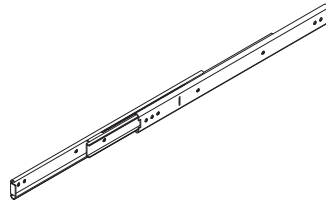

Model FBL 35D

## Model FBL 51H

A three-rail double slide that allows a long stroke. A thin model that can be used in small spaces, even with large working loads.

Specification Table⇒ [A13-29](#)

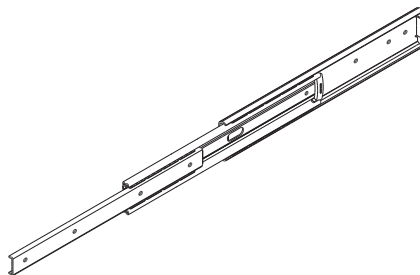

Model FBL 51H

## Model FBL 51H-P13

A three-rail double slide that allows a long stroke. A thin model that can be used in small spaces, even with large working loads. The inner rail can be pulled out, and locked states caused by the disconnection spring can be manually released when retracted. It is also equipped with a useful locking mechanism that engages when the slide rail is fully opened.

Specification Table⇒ [A13-30](#)

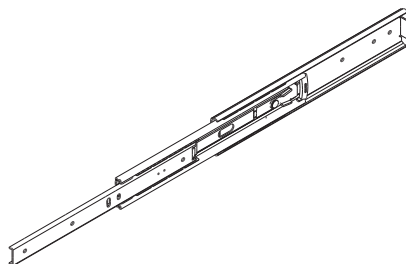

Model FBL 51H-P13

## Model FBL 51H-P14

A three-rail double slide that allows a long stroke. A thin model that can be used in small spaces, even with large working loads. The inner rail can be pulled out, and it can be automatically unlocked by pushing it further into the outer rail.

Specification Table⇒ [A13-31](#)

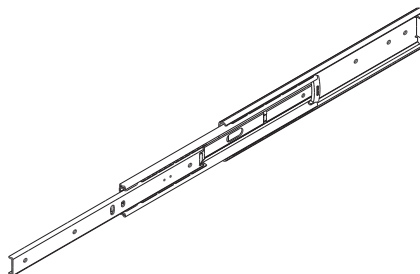

Model FBL 51H-P14

[Double Slides for Heavy Load]

## Model FBL 35K

A double slide combining four Model FBL 35S units. It features the largest allowable load among all models, making it suitable for opening/closing heavy objects.

Specification Table⇒ **A** 13-32

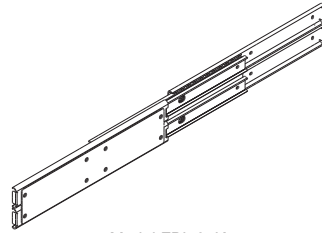

Model FBL 35K

## Model FBL 56H

Three-rail double slide with a large allowable load. Widely used in many types of office furniture.

Specification Table⇒ **A** 13-33

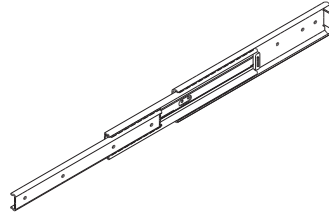

Model FBL 56H

## Model FBL 56H-P13

Three-rail double slide with a large allowable load. The inner rail can be pulled out, and it can be manually unlocked when retracted. It is also equipped with a useful locking mechanism that engages when the slide rail is fully opened.

Specification Table⇒ **A** 13-34

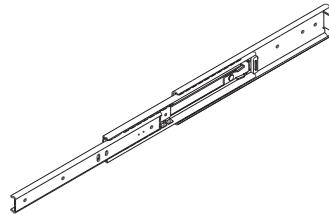

Model FBL 56H-P13

## Model FBL 56H-P14

Three-rail double slide with a large allowable load. The inner rail can be pulled out, and it can be automatically unlocked by pushing it further into the outer rail.

Specification Table⇒ **A** 13-35

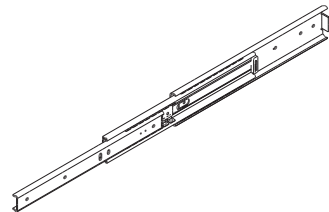

Model FBL 56H-P14

[Linear Type Slides]

## Light Load Type Model FBL 35F

Linear-type slide suitable for limited straight motion, featuring a flange for easy mounting.

Specification Table⇒ **A13-36**

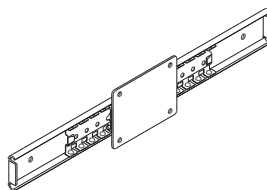

Light Load Type Model FBL 35F

[Wheel-type Linear Slide]

## Model E36RS

A linear slide that features wear-resistant resin bearings.

Specification Table⇒ **A13-37**

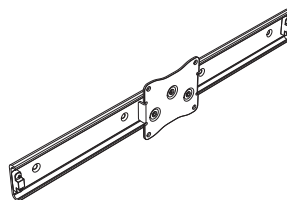

Model E36RS

**[Aluminum Alloy Slide Rail]****Light Load Type Model E15**

A compact and lightweight single slide from the aluminum alloy series. Suitable for locations within magnetic fields, locations requiring rust-resistant materials, and locations where appearance is a factor.

Specification Table⇒ **A** 13-38

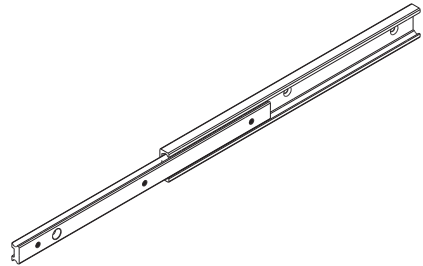

Light Load Type Model E15

**Light Load Type Model E20**

A basic single slide from the aluminum alloy series. Suitable for locations within magnetic fields, locations requiring rust-resistant materials, and locations where appearance is a factor.

Specification Table⇒ **A** 13-39

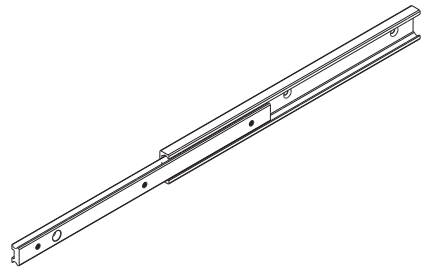

Light Load Type Model E20

**Light Load Type Model D20**

The most compact and lightweight double slide in the aluminum alloy series. Suitable for locations within magnetic fields, locations requiring rust-resistant materials, and locations where appearance is a factor.

Specification Table⇒ **A** 13-40

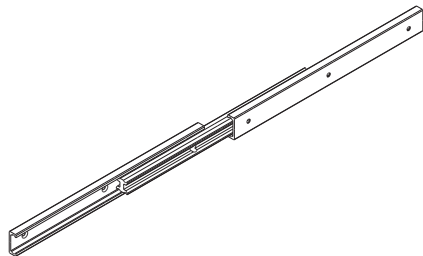

Light Load Type Model D20

# Classification Table for Slide Rails

## Slide Rail

### Single Slide

#### For Light Load

**Model FBL27S**

**Model FBL27S-P14**

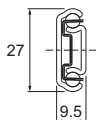

**Model FBL35J**

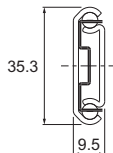

**Model FBL35S**

**Model FBL35S-P13**

**Model FBL35S-P14**

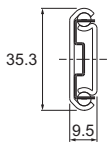

**Model FBL35B**

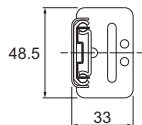

**Model E15**  
(Made of Aluminum)

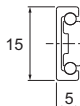

**Model FBL35M**

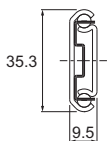

**Model E20**  
(Made of Aluminum)

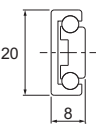

### Double Slide

#### For Light Load

**Model FBL27D**

**Model D20**  
(Made of aluminum)

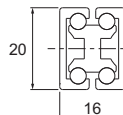
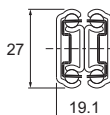

**Model FBL35N**

**Model FBL35N-P16**

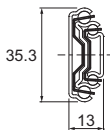

#### For Medium Load

**Model FBL35G-P13**

**Model FBL51H**

**Model FBL35G-P14**

**Model FBL51H-P13**

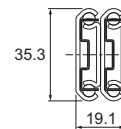

**Model FBL51H-P14**

**Model FBL35D**

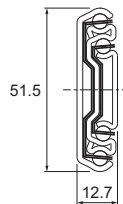
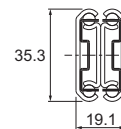

## Features and Types

## Classification Table for Slide Rails

## Linear Type Slide

## For Heavy Load

Model FBL35K

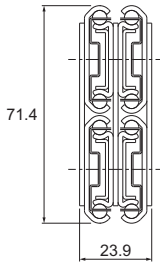

Model FBL56H

Model FBL56H-P13

Model FBL56H-P14

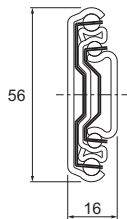

## For Light Load

Model FBL35F

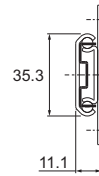

## Wheel Type

Model E36RS (Aluminum Outer Rail)

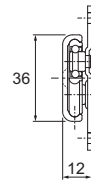

Slide Rail

## Mounting the Slide Rail

### [Mounting Screws of the Slide Rail]

The slide rail is designed to be mounted using M4 screws. Since the mounting space is small as shown in Fig.1, we recommend using button head or binding head bolts.

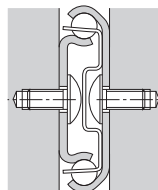

Fig.1

Note that the mounting screw for the slide rail of the models indicated in the following table is different.

| Model number              | button-head bolt | binding-head bolt | countersink screw |
|---------------------------|------------------|-------------------|-------------------|
| Models FBL27S/27S-P14/27D | M3               | M3 , M4           | —                 |
| Model E15                 | —                | —                 | M2.6              |
| Models E20/D20            | —                | —                 | M3                |
| Model E36RS               | —                | —                 | M4                |

Note: For button head bolts, binding head bolts, and countersink screws, see the appendix of JIS B 1111.

### [Attaching the Slide Rail]

At full extension of the slide, mount the outer rail at the overlap of rails. Followed by full retraction of the slide and mount the opposite end using the access hole.

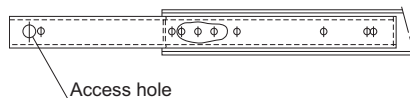

Fig.2

Note: For the following model numbers, mount outer rail after removing inner rail, as shown in Fig.3.

Models: FBL27S-P14, FBL35S-P13, FBL35S-P14, FBL35M, FBL35J, FBL35B, FBL35N-P16, FBL35G-P13, FBL35G-P14, FBL51H-P13, FBL51H-P14, FBL56H-P13, FBL56H-P14

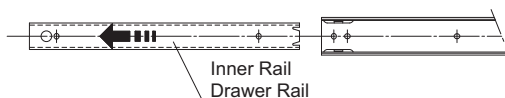

Fig.3

## Mounting Procedure

### Mounting the Slide Rail

In addition, when mounting the outer rail or cabinet rail of models FBL35G-P13, FBL35G-P14, FBL51H-P13 and FBL56H-P13, which have locking mechanisms, release the lock by pressing the lock plate in the direction indicated in Fig.4 and adjust the position of the access hole.

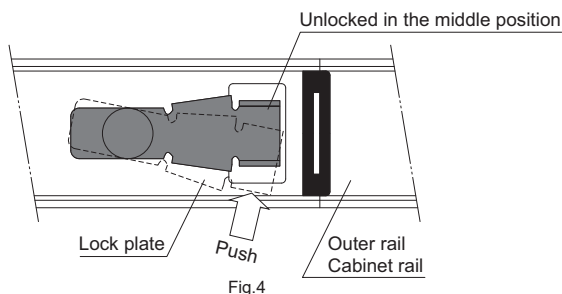

Fig.4

Note: For the following models, mount the inner rail by sliding it in the contracting direction as show in Fig.5. When doing so, do not remove the inner rail from the outer rail. If the inner rail is pulled out, it may be difficult to reinsert.

Models: FBL27S, FBL35S

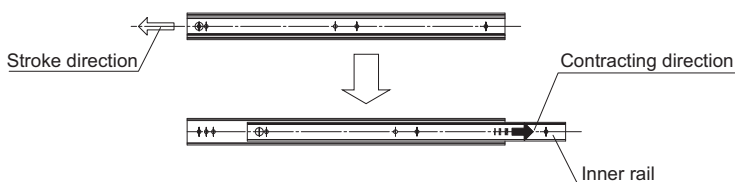

Fig.5

### [Permissible Load and Mounting Orientation]

For use other than with the mounting orientation shown in Fig.6, contact THK.

The permissible load of the Slide Rail indicates the load in the direction  $P_a$  that two rails can receive in the middle of the inner rail length at the maximum stroke.

The mounting orientation shown in Fig.7 is applicable to "model FBL35B" only.

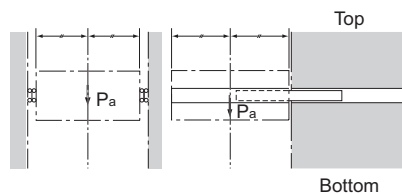

Fig.6

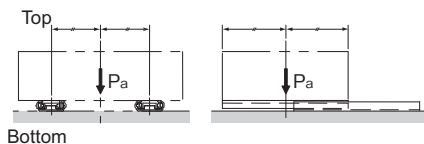

Fig.7 Applicable to "model FBL35B" only

The mounting orientation of Fig.8 is applicable to model FBL35F.

The mounting orientation of Fig.9 is applicable to model E36RS.

Unlike other slide rails, model E36RS is used in a single rail configuration. Therefore, the load must be centered on the ball and the cage center line.

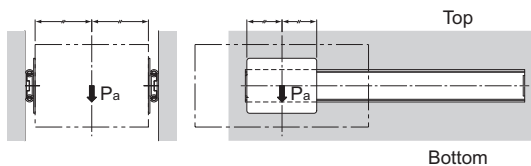

Fig.8

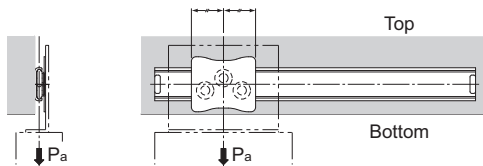

Fig.9

#### [Surface Treatment]

The surface of the Slide Rail is electro-galvanized (treated with trivalent chromate) as standard.

The aluminum slide rail of models E and D is white alumite-treated as standard. The slider of model E36RS is electro-galvanized (trivalent chromate treatment) and the rail is white alumite-treated as standard. For other surface treatments, contact THK.

---

## Model Number Coding

---

Model number configurations differ depending on the model features. Refer to the corresponding sample model number configuration.

### [Single slide/Double slide]

- Models FBL 27S, FBL 27S-P14, FBL 35S, FBL 35S-P13, FBL 35S-P14, FBL 35M, FBL 35J, FBL 35B, FBL 27D, FBL 35N, FBL 35N-P16, FBL 35G-P13, FBL 35G-P14, FBL 35D, FBL 51H, FBL 51H-P13, FBL 51H-P14, FBL 35K, FBL 56H, FBL 56H-P13 and FBL 56H-P14
- 

**FBL27S +300L**

Model No. Overall rail length (in mm)

---

### [Linear Type Slides]

- Model FBL35F
- 

**FBL35F +356L #5**

Model No. Overall rail length (in mm) Model number of mounting plate

---

### [Linear Slide Wheel-type]

- Model E36RS
- 

**E36RS +550L**

Model number Overall rail length (mm)

---

### [Aluminum Alloy Slide Rail]

- Models E15, E20 and D20
- 

**E15 +100L**

Model No. Overall rail length (in mm)

---

## Precautions on Use

## Slide Rail

### [Handling]

- (1) Tilting a Slide Rail may cause it to fall by its own weight.
- (2) Do not disassemble the parts. This will result in loss of functionality.
- (3) Take care not to drop or strike the Slide Rail. Doing so may cause injury or damage. Giving an impact to it could also cause damage to its function even if the product looks intact.
- (4) When handling the product, wear protective gloves, safety shoes, etc., as necessary to ensure safety.

### [Precautions on Use]

- (1) When mounting the Slide Rail, use care to always keep both rails in parallel.
- (2) Prevent foreign material, such as cutting chips or coolant, from entering the product. Failure to do so may cause damage.
- (3) If the product is used in an environment where cutting chips, coolant, corrosive solvents, water, etc., may enter the product, use bellows, covers, etc., to prevent them from entering the product.
- (4) If foreign material such as cutting chips adheres to the product, replenish the lubricant after cleaning the product.
- (5) Avoid using the product at other than normal temperature, or using it in harsh conditions such as intensive reciprocations that generate frictional heat and environments with water or dust.
- (6) The durability of the Slide Rail varies depending on factors such as the drawing dimension, travel distance, mounting conditions and environment in addition to operating frequency. Take these factors into account when making a selection.
- (7) Note that the cage creep may occur if the slide rail is mounted vertically, subject to machine vibrations, etc. To correct the cage creep, fully open and fully close the slide rail. During this process, the motion will be less smooth than usual. If cage creep is inevitable, we recommend using Slide Packs, LM Guides, etc., which are infinite stroke linear motion systems.
- (8) If you replace an old slider or outer rail of your E36RS with a new one, the clearance and sliding resistance may substantially increase.
- (9) Do not use the supplied stopper as a mechanical stopper. This may damage the stopper due to impact.
- (10) Do not use undue force when fitting parts (pin, key, etc.) to the product. This may generate pressure marks on the raceway, leading to loss of functionality.
- (11) Insufficient rigidity or accuracy of mounting members causes the bearing load to concentrate on one point and the bearing performance will drop significantly. Accordingly, give sufficient consideration to the rigidity/accuracy of the housing and base and strength of the fixing bolts.

### [Lubrication]

- (1) Lithium soap-based grease No. 2 is applied to the slide rail. Do not mix different lubricants. Even greases containing the same type of thickening agent may, if mixed, interact adversely due to disparate additives or other ingredients.
- (2) The consistency of grease changes according to the temperature. Take note that the slide resistance of the Slide Rail also changes as the consistency of grease changes.
- (3) After lubrication, the slide resistance of the Slide Rail may increase due to the agitation resistance of grease. Be sure to let the grease spread fully before use.
- (4) Excess grease may scatter immediately after lubrication, so wipe off scattered grease as necessary.
- (5) The properties of grease deteriorate and its lubrication performance drops over time, so grease must be checked and added properly according to the use frequency of the machine.
- (6) The greasing interval varies depending on the use condition and service environment. Set the final lubrication interval/amount based on the actual machine.

**[Storage]**

When storing the Slide Rail, enclose it in a package designated by THK and store it in a room in a horizontal orientation while avoiding high temperature, low temperature and high humidity.

After the product has been in storage for an extended period of time, lubricant inside may have deteriorated, so add new lubricant before use.

**[Disposal]**

Dispose of the product properly as industrial waste.

