

Precision Ballscrew EPA

- Single nut according to DIN 69051 (1989) with flange form A
- Type EPA: Preload by pitch shifting
- Ground or precision rolled screw shafts available

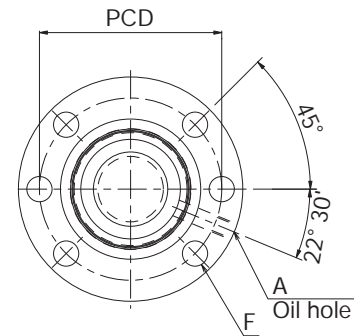

Drilling template 1

Model number	Screw shaft diameter d	Lead ℓ	Ball center-to-center diameter dp	Thread minor diameter d ₃	No. of loaded circuits/rows × turns	Basic load rating		Rigidity ¹⁾ K [N/μm]
						C _a [kN]	C _{0a} [kN]	
* EPA1605-6RR	16	5	16.75	13.5	3×1	7.9	12.7	360
* EPA2005-6RR	20	5	20.75	17.5	3×1	9.2	16.9	439
* EPA2505-6RR	25	5	25.75	22.5	3×1	10.5	22.2	532
* EPA2510-4RR	25	10	26	21.9	2×1	9.8	17.6	369
* EPA3205-6RR	32	5	32.75	29.5	3×1	11.9	29.6	655
* EPA3205-8RR	32	5	32.75	29.5	4×1	15.3	39.5	862
* EPA3210-6RR	32	10	33.75	27.2	3×1	27.9	51.0	691
EPA4005-6RR	40	5	40.75	37.5	3×1	13.3	38.1	788
* EPA4010-6RR	40	10	41.75	35.2	3×1	32.4	67.8	842
* EPA4010-8RR	40	10	41.75	35.2	4×1	41.5	90.4	1108
EPA5005-6RR	50	5	50.75	47.5	3×1	14.6	48.7	945
EPA5005-12RR	50	5	50.75	47.5	6×1	26.6	97.3	1830
EPA5010-8RR	50	10	51.75	45.2	4×1	47.2	118.5	1342
EPA6310-8RR	63	10	64.7	58.2	4×1	53.9	157.8	1654

* Also available with precision rolled screw shaft (Cp3 und Cp5).

¹⁾ The rigidity values in this table indicate spring constants obtained from the load and elastic displacement under a preload of 10% of the basic dynamic load rating C_a, and an axial load F_a that is three times that of the preload F_{a0}. As these values do not take into account the rigidity of the parts involved in the nut installation, take 80% of the values given in this table as a general guideline.

If the preload F_{a0} differs from 0.1 C_a, the rigidity K_N can be calculated using the following equation:

$$K_N = K \cdot \left(\frac{F_{a0}}{0.1 C_a} \right)^{\frac{1}{3}} \cdot 0.8$$

If the ballscrew is not preloaded, please consult **THK** for the rigidity value.

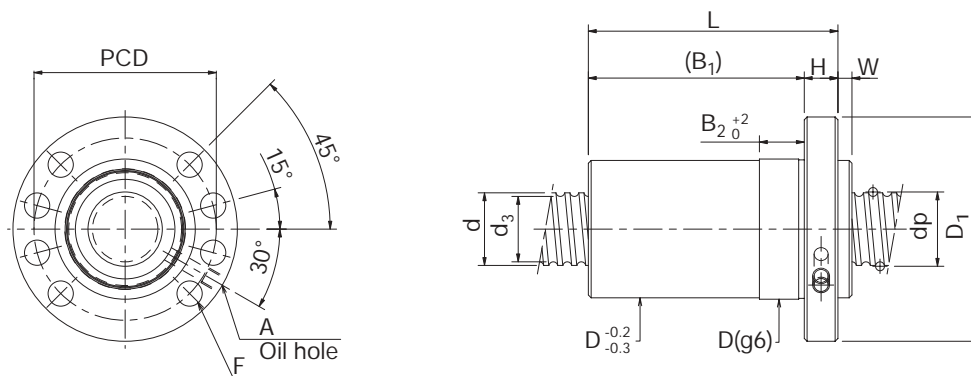

Drilling template 2

Unit: mm

Nut dimensions										Drilling template	Oil hole A	Screw shaft inertial moment per mm [kg·cm ² /mm]
Outer diameter D	Flange diameter D ₁	Overall length L	H	B ₁	B ₂	W	PCD	F				
28	48	60	10	50	10	5	38	5.5	1	M6×1	5.05×10 ⁻⁴	
36	58	61	10	51	10	5	47	6.6	1	M6×1	1.23×10 ⁻³	
40	62	61	10	51	10	5	51	6.6	1	M6×1	3.01×10 ⁻³	
40	62	80	10	70	16	5	51	6.6	1	M6×1	3.01×10 ⁻³	
50	80	62	12	50	10	5	65	9	1	M6×1	8.08×10 ⁻³	
50	80	73	12	61	10	5	65	9	1	M6×1	8.08×10 ⁻³	
50	80	107	12	95	10	5	65	9	1	M6×1	8.08×10 ⁻³	
63	93	65	14	51	10	5	78	9	2	M8×1	1.97×10 ⁻²	
63	93	109	14	95	16	5	78	9	2	M8×1	1.97×10 ⁻²	
63	93	133	14	119	16	5	78	9	2	M8×1	1.97×10 ⁻²	
75	110	70	16	54	10	5	93	11	2	M8×1	4.82×10 ⁻²	
75	110	105	16	89	10	5	93	11	2	M8×1	4.82×10 ⁻²	
75	110	135	16	119	16	5	93	11	2	M8×1	4.82×10 ⁻²	
90	125	137	18	119	16	5	108	11	2	M8×1	1.21×10 ⁻¹	

Model-Number Coding

EPA 32 05 – 4 RR G0 + 1200L Cp5

(1) (2) (3) (4) (5) (6) (7) (8)

- (1) Nut
- (2) Screw shaft outer diameter (mm)
- (3) Lead (mm)
- (4) Number of circuits (rows × turns)
- (5) Seals (RR: labyrinth seals attached to both sides)
- (6) Preload
- (7) Screw shaft total length (mm)
- (8) Accuracy (see page 10 - 15)