

NR-X/NRS-X

Super-Heavy Load LM Guide Model NR-X/NRS-X for Machine Tools

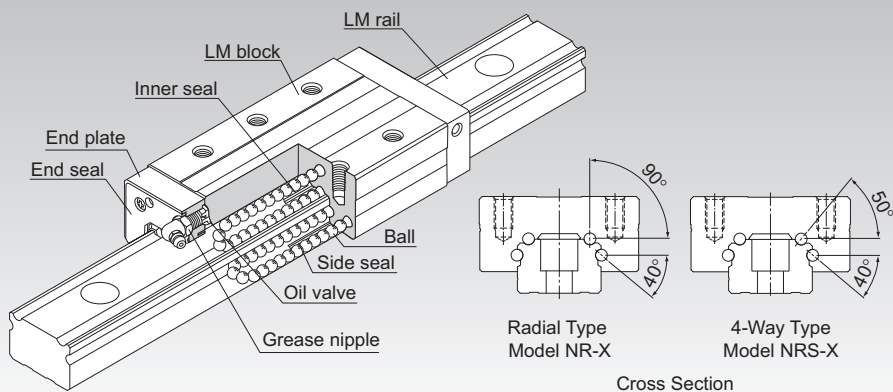

Selection Criteria **A1-10**

Design Highlights **A1-482**

Options **A1-507**

Model No. **A1-577**

Handling Precautions **A1-583**

Accessories for Lubrication **A24-1**

Mounting Procedure **B1-89**

Equivalent Moment Factor **A1-43**

Rated Loads in All Directions **A1-61**

Equivalent Factor in Each Direction **A1-63**

Radial Clearance **A1-73**

Accuracy Standards **A1-79**

Shoulder Height of the Mounting Base and the Corner Radius **A1-492**

Reference Error Tolerance for the Mounting Surface **A1-498**

Dimensions of Each Model with Options Attached **A1-521**

Structure and Features

Balls roll in four rows of raceways precision-ground on an LM rail and an LM block, and end plates incorporated in the LM block allow the balls to circulate. The raceways are cut into deep grooves that have a radius closer to that of the balls than in the conventional design, using special equipment and an extremely precise cutting technique. This design allows high rigidity, high vibration and impact resistance, and high damping capacity, all of which are required for machine tools, thus making these models capable of bearing super-heavy loads.

Notes: Due to the extremely high rigidity of LM Guide units of models NR-X and NRS-X, the construction does not easily absorb the effects of mounting surface misalignment and installation errors. Where such effects arise, there is a risk of reduced operating life and/or malfunction. Contact THK when considering the use of these products.

Improved Damping Capacity

While not performing cutting operations, the LM Guide travels normally and smoothly. While cutting a workpiece, the cutting force is applied to the LM Guide and increases the contact area between the balls and the raceway, allowing an appropriate mixture of rolling and sliding motion to be achieved. Accordingly, the friction resistance is increased and the damping capacity is improved. Since the absolute slip during the rolling and sliding motion is insignificant, it causes little wear and does not affect the service life.

Highly Practical LM Guide

The excessively large differential slip occurring in a Gothic-arch groove does not happen with these models. They smoothly travel and achieve high positioning accuracy during fast feeding. NR and NRS are extremely practical models of LM Guide that generate differential slip appropriate to the cutting load, increase rolling resistance and damping, and improve cutting performance.

High Rigidity

To increase the rigidity of the LM block and the LM rail, which may impact the overall rigidity of the LM Guide in the reverse-radial and lateral directions, THK made full use of FEM to achieve optimal design within the limited dimensional range.

THK offers two identically sized models with different characteristics, namely the radial type Model NR-X and 4-way type Model NRS-X. Users can select the model that best suits their specifications.

Super-Heavy Load

Since the curvature of the raceway is matched to the ball diameter, the ball contact area under a load is increased and the LM Guide is capable of receiving a super-heavy load.

Types and Features

Models NR-RX/NRS-RX

With this type, the LM block has a smaller width (W) and tapped holes. It is used in places where the space for table width is limited.

Dimensional Table⇒ [A1-232](#)/[A1-234](#)

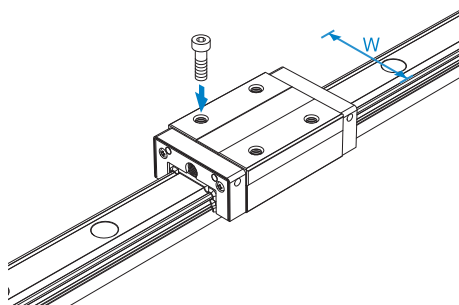

Models NR-LRX/NRS-LRX

The LM block has the same cross-sectional shape as models NR-RX/NRS-RX, but has a longer overall LM block length (L) and a greater load rating.

Dimensional Table⇒ [A1-232](#)/[A1-234](#)

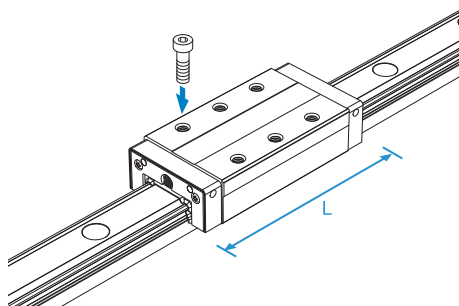

Models NR-SLRX/NRS-SLRX

The LM block has the same cross-sectional shape as models NR-LRX/NRS-LRX, but has a longer overall LM block length (L) and a greater load rating.

Dimensional Table⇒ [A1-232](#)/[A1-234](#)

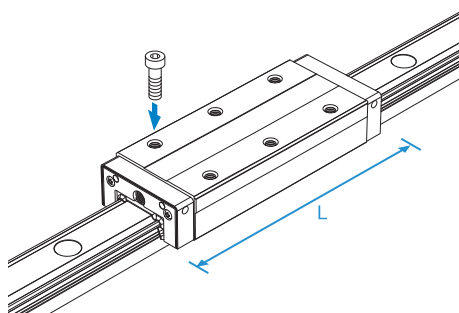

Models NR-CX/NRS-CX

The flange of the LM block has tapped holes. It can be mounted from the top or the bottom. It can also be used in places where the table cannot have through holes for mounting bolts.

Dimensional Table → [A1-238/A1-240](#)

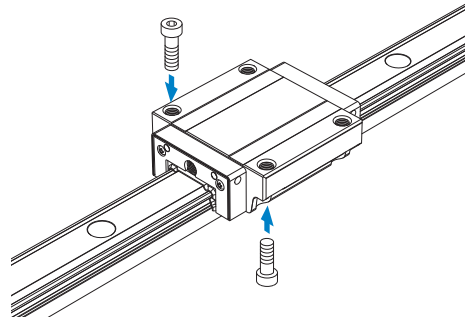

LM Guide

Models NR-LCX/NRS-LCX

The LM block has the same cross-sectional shape as models NR-CX/NRS-CX, but has a longer overall LM block length (L) and a greater load rating.

Dimensional Table → [A1-238/A1-240](#)

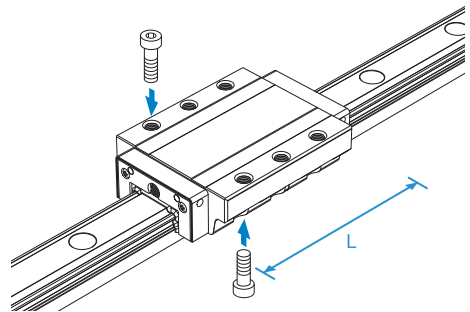

Models NR-SLCX/NRS-SLCX

The LM block has the same cross-sectional shape as models NR-LCX/NRS-LCX, but has a longer overall LM block length (L) and a greater load rating.

Dimensional Table → [A1-238/A1-240](#)

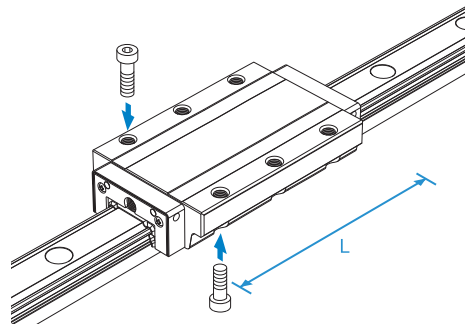

Models NR-R/NRS-R

With this type, the LM block has a smaller width (W) and tapped holes. It is used in places where the space for table width is limited.

Dimensional Table⇒ [A1-236](#)

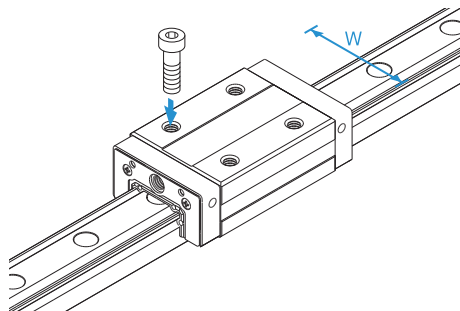

Models NR-LR/NRS-LR

The LM block has the same cross-sectional shape as models NR-R/NRS-R, but has a longer overall LM block length (L) and a greater load rating.

Dimensional Table⇒ [A1-236](#)

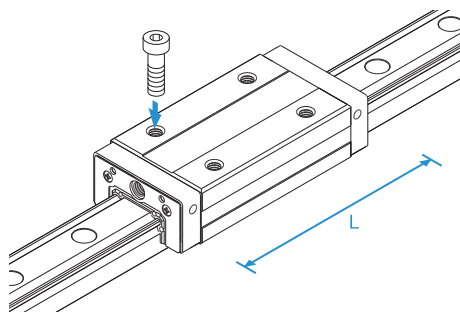

Models NR-A/NRS-A

The flange of its LM block has tapped holes.

Dimensional Table⇒ [A1-242](#)

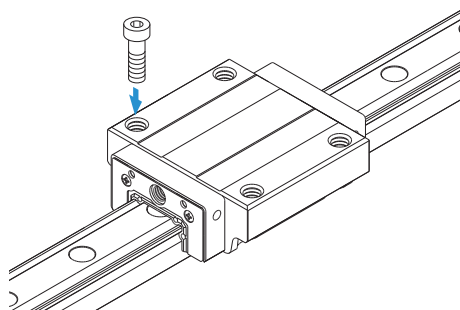

Models NR-LA/NRS-LA

The LM block has the same cross-sectional shape as models NR-A/NRS-A, but has a longer overall LM block length (L) and a greater load rating.

Dimensional Table⇒ **A1-242**

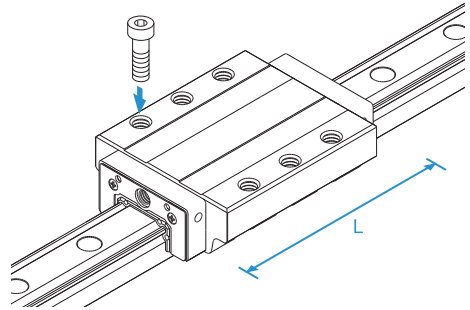

LM Guide

Models NR-B/NRS-B

The flange of the LM block has through holes. It is used in places where the table cannot have through holes for mounting bolts.

Dimensional Table⇒ **A1-244**

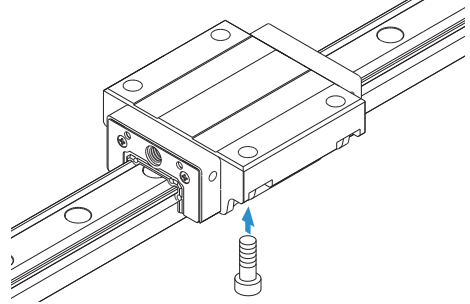

Models NR-LB/NRS-LB

The LM block has the same cross-sectional shape as models NR-B/NRS-B, but has a longer overall LM block length (L) and a greater load rating.

Dimensional Table⇒ **A1-244**

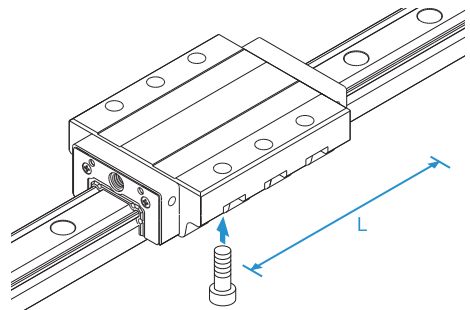

Models NR-RX, NR-LRX, and NR-SLRX

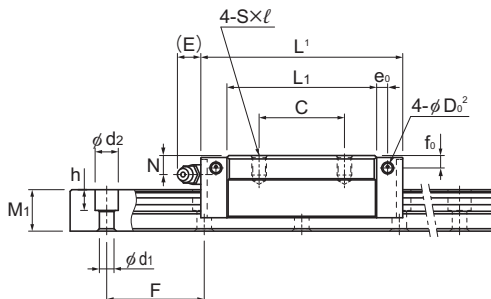
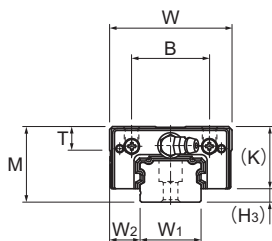

Model NR-RX

Model No.	Outer dimensions			LM block dimensions										Pilot hole for side nipple			
	Height M	Width W	Length ¹ L	B	C	S × ℓ	L ₁	T	K	N	E	Grease nipple	e ₀	f ₀	D ₀ ²	H ₃	
NR 25RX NR 25LRX NR 25SLRX	31	50	82.8 102 170.3	32	35 50 100	M6 × 8	61.4 80.6 148.9	9.7	25.5	7.8	12	B-M6F	4.5	5.1	3.9	5.5	
NR 30RX NR 30LRX NR 30SLRX	38	60	98 120.5 204.6	40	40 60 120	M8 × 10	72.1 94.6 178.7	9.7	31	10.3	12	B-M6F	6.5	7	3.9	7	
NR 35RX NR 35LRX NR 35SLRX	44	70	109.5 135 238.9	50	50 72 140	M8 × 12	79 104.5 208.4	11.7	35	12.1	12	B-M6F	6	8	5.2	9	
NR 45RX NR 45LRX NR 45SLRX	52	86	138.2 171 271.4	60	60 80 160	M10 × 17	105 137.8 238.2	14.7	40.4	13.9	16	B-PT1/8	8.5	8	5.2	11.6	
NR 55RX NR 55LRX NR 55SLRX	63	100	163.3 200.5 400.5	65	75 95 206	M12 × 18	123.6 160.8 360.8	17.7	49	16.6	16	B-PT1/8	10	10	5.2	14	
NR 65RX NR 65LRX NR 65SLRX	75	126	186 246 422.2	76	70 110 250	M16 × 20	143.6 203.6 379.8	21.6	60	19	16	B-PT1/8	8.7	15	8.2	15	

Model number coding

NR35 LRX 2 QZ KKHH C0 +1240L P T - II

Model number

Type of LM block

With QZ Lubricator

Contamination protection accessory symbol

LM rail length (in mm)

Symbol for LM rail jointed use

Symbol for No. of rails used on the same plane

No. of LM blocks used on the same rail

Radial clearance symbol
Normal (No symbol)
Light preload (C1)
Medium preload (C0)

Accuracy symbol
Normal grade (No Symbol)/High accuracy grade (H)
Precision grade (P)/Super precision grade (SP)
Ultra precision grade (UP)

Notes: This model number indicates that a single-rail unit constitutes one set (i.e., required number of sets when 2 rails are used in parallel is 2 at a minimum).

Grease nipples are not installed when there is a QZ Lubricator. Contact THK if you want to use a grease nipple for a model with a QZ. See **A1-547** for contamination protection accessories, see **A1-73** for radial clearance symbol. See **A1-79** for accuracy symbol. See **A1-13** for symbol for number of rails used on the same plane.

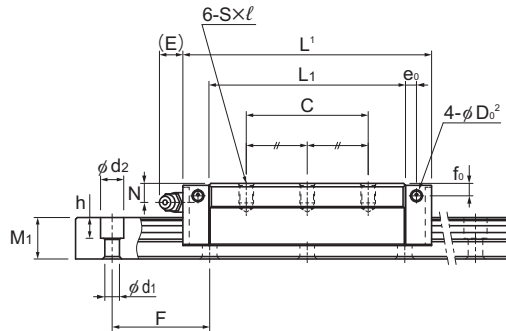

Models NR-LRX/SLRX

Unit: mm

LM rail dimensions						Basic load rating ¹		Static permissible moment kN·m ⁵					Mass	
Width W ₁ 0 -0.05	Height W ₂	Pitch M ₁	Pitch F	Length ³ d ₁ × d ₂ × h	Length ³ Max	C kN	C ₀ kN	M _A		M _B		M _C	LM block kg	LM rail kg/m
								1 block	2 blocks	1 block	2 blocks	1 block		
25	12.5	17	40	6 × 9.5 × 8.5	3000	37.1	68.1	0.57	3.04	0.346	1.84	0.703	0.4	2.9
						45.4	90.8	0.989	4.91	0.597	2.95	0.937		
						71	172.6	3.37	15.3	2.02	9.15	1.8		
28	16	21	80	7 × 11 × 9	3000	54.7	98.1	0.986	5.17	0.599	3.13	1.15	0.7	4.2
						66.9	130.8	1.71	8.34	1.03	5.02	1.53		
						104.8	248.6	5.82	26.4	3.49	15.8	2.95		
34	18	24.5	80	9 × 14 × 12	3000	72.4	124.6	1.37	7.38	0.835	4.48	1.74	1	6
						89.6	169.1	2.46	12.1	1.49	7.3	2.36		
						145.6	338.2	9.23	42	5.54	25.2	4.78		
45	20.5	29	105	14 × 20 × 17	3090	110.2	197.6	2.81	14.7	1.72	8.95	3.72	1.8	9.5
						132	255.8	4.87	23	2.94	13.8	4.81		
						193.5	441.8	13.8	62.3	8.27	37.3	8.32		
53	23.5	36.5	120	16 × 23 × 20	3060	141.9	250.2	4.22	21.8	2.56	13.2	5.37	3.3	14
						175.1	338.4	7.27	35.9	4.4	21.7	7.27		
						305.8	750.5	35.2	155	21.1	92.7	16.2		
63	31.5	43	150	18 × 26 × 22	3000	208.7	351.7	6.87	35	4.16	21.2	8.94	6	19.6
						268.9	505.5	13.8	65.4	8.31	39.3	12.9		
						423.1	967.1	47.9	211	28.7	126	24.8		

¹ Length L shown in the table is the length with the contamination protection accessories, code UU or SS.
If other contamination protection accessories or lubricant equipment are installed, the total block length will increase. (See **A1-521** or **A1-543**)

² D₀ are the pilot holes for when a grease nipple is desired for a product with LaCS or a QZ Lubricator.
Pilot holes are not drilled through for models other than those stated above.
For grease nipple mount machining, contact THK.

³ The maximum length indicates the standard maximum length of an LM rail. (See **A1-246**.)

⁴ The basic load rating is for a load in the radial direction.

Use **A1-61** on Table 7 to calculate the load rating for loads in the reverse-radial direction or lateral direction.

⁵ Static permissible moment 1 block: the static permissible moment with one LM block
2 blocks: the static permissible moment with two LM blocks in close contact with each other

Note: For oil lubrication, be certain to let THK know the mounting orientation and where the LM block piping joint should be attached.
(Mounting orientation: see **A1-12**, Lubricant: see **A24-2**)

Models NRS-RX, NRS-LRX, and NRS-SLRX

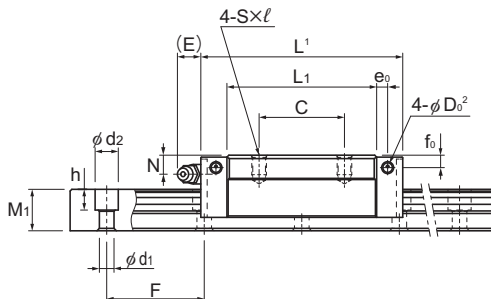
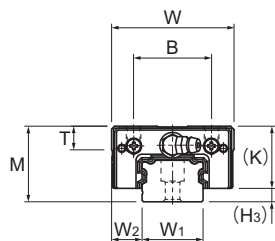

Model NRS-RX

Model No.	Outer dimensions			LM block dimensions										Pilot hole for side nipple			
	Height	Width	Length ¹	B	C	S×ℓ	L ₁	T	K	N	E	Grease nipple	e ₀	f ₀	D ₀ ²	H ₃	
	M	W	L														
NRS 25RX NRS 25LRX NRS 25SLRX	31	50	82.8 102 170.3	32	50	M6×8	61.4 80.6 148.9	9.7	25.5	7.8	12	B-M6F	4.5	5.1	3.9	5.5	
NRS 30RX NRS 30LRX NRS 30SLRX	38	60	98 120.5 204.6	40	60	M8×10	72.1 94.6 178.7	9.7	31	10.3	12	B-M6F	6.5	7	3.9	7	
NRS 35RX NRS 35LRX NRS 35SLRX	44	70	109.5 135 238.9	50	72	M8×12	79 104.5 208.4	11.7	35	12.1	12	B-M6F	6	8	5.2	9	
NRS 45RX NRS 45LRX NRS 45SLRX	52	86	138.2 171 271.4	60	80	M10×17	105 137.8 238.2	14.7	40.4	13.9	16	B-PT1/8	8.5	8	5.2	11.6	
NRS 55RX NRS 55LRX NRS 55SLRX	63	100	163.3 200.5 400.5	65	95	M12×18	123.6 160.8 360.8	17.7	49	16.6	16	B-PT1/8	10	10	5.2	14	
NRS 65RX NRS 65LRX NRS 65SLRX	75	126	186 246 422.2	76	110	M16×20	143.6 203.6 379.8	21.6	60	19	16	B-PT1/8	8.7	15	8.2	15	

Model number coding

NRS45	LRX	2	QZ	ZZHH	C0	+1200L	P	T	-II
Model number	Type of LM block	With QZ Lubricator	Contamination protection accessory symbol	Radial clearance symbol Normal (No symbol)/Light preload (C1) Medium preload (C0)	LM rail length (in mm)	Accuracy symbol Normal grade (No Symbol)/High accuracy grade (H) Precision grade (P)/Super precision grade (SP) Ultra precision grade (UP)	Symbol for LM rail jointed use	Symbol for No. of rails used on the same plane	
	No. of LM blocks used on the same rail								

Notes: This model number indicates that a single-rail unit constitutes one set (i.e., required number of sets when 2 rails are used in parallel is 2 at a minimum).

Grease nipples are not installed when there is a QZ Lubricator. Contact THK if you want to use a grease nipple for a model with a QZ. See **A1-547** for contamination protection accessories, see **A1-73** for radial clearance symbol. See **A1-79** for accuracy symbol. See **A1-13** for symbol for number of rails used on the same plane.

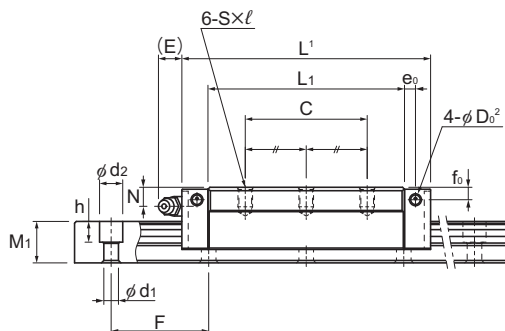

Models NRS-LRX/SLRX

Unit: mm

	LM rail dimensions					Basic load rating ¹		Static permissible moment kN·m ⁵					Mass	
	Width W ₁ 0 -0.05	Height W ₂	Pitch M ₁	Pitch F	Length ³ d ₁ × d ₂ × h Max	C kN	C ₀ kN	M _A		M _B		M _C	LM block kg	LM rail kg/m
								1 block	2 blocks	1 block	2 blocks	1 block		
25	12.5	17	40	6 × 9.5 × 8.5	3000	28.4 34.7 54.4	52.2 69.6 132.2	0.457 0.786 2.66	2.43 3.9 12.1	0.422 0.727 2.46	2.25 3.61 11.2	0.552 0.732 1.33	0.4 0.5 0.9	2.9
28	16	21	80	7 × 11 × 9	3000	41.9 51.2 80.3	75.2 100.2 190.4	0.785 1.36 4.6	4.12 6.62 20.9	0.422 1.26 4.25	2.25 3.82 19.3	0.896 1.19 2.17	0.7 0.9 1.7	4.2
34	18	24.5	80	9 × 14 × 12	3000	55.5 68.6 111.5	95.5 129.5 259.1	1.09 1.95 7.3	5.88 9.61 33.2	1.01 1.81 6.75	5.45 8.9 30.7	1.36 1.84 3.53	1 1.3 2.6	6
45	20.5	29	105	14 × 20 × 17	3090	84.4 101.1 148.3	151.4 195.9 338.4	2.23 3.87 10.9	11.7 18.3 49.2	2.07 3.57 10.1	10.8 16.9 45.5	2.9 3.75 6.22	1.8 2.3 4	9.5
53	23.5	36.5	120	16 × 23 × 20	3060	108.7 134.1 234.3	191.6 259.3 574.9	3.36 5.76 27.8	17.4 28.4 123	3.1 5.32 25.7	16.1 26.3 113	4.19 5.67 12	3.3 4.3 9.6	14
63	31.5	43	150	18 × 26 × 22	3000	159.8 206 324.1	269.4 387.2 740.8	5.46 10.9 37.9	27.8 51.9 167	5.05 10.1 35	25.8 48 154	6.97 10.02 18.4	6 8.5 15.9	19.6

¹ Length L shown in the table is the length with the contamination protection accessories, code UU or SS. If other contamination protection accessories or lubricant equipment are installed, the total block length will increase. (See [A1-521](#) or [A1-543](#))

² D₀ are the pilot holes for when a grease nipple is desired for a product with LaCS or a QZ Lubricator. Pilot holes are not drilled through for models other than those stated above. For grease nipple mount machining, contact THK.

³ The maximum length indicates the standard maximum length of an LM rail. (See [A1-246](#).)

⁴ The basic load rating is for a load in the radial direction.

Use [A1-61](#) on Table 7 to calculate the load rating for loads in the reverse-radial direction or lateral direction.

⁵ Static permissible moment 1 block: the static permissible moment with one LM block
2 blocks: the static permissible moment with two LM blocks in close contact with each other

Note: For oil lubrication, be certain to let THK know the mounting orientation and where the LM block piping joint should be attached. (Mounting orientation: see [A1-12](#), Lubricant: see [A24-2](#))

Models NR-R, NR-LR, NRS-R, and NRS-LR

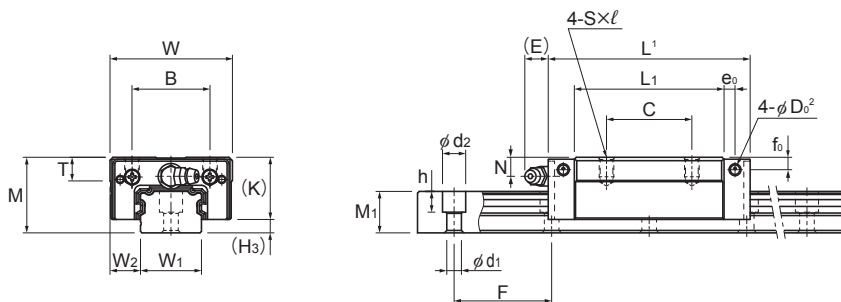

Models NR-R and NRS-R

Model No.	Outer dimensions			LM block dimensions										Pilot hole for side nipple			
	Height	Width	Length ¹	B	C	S×ℓ	L ₁	T	K	N	E	Grease nipple	e ₀	f ₀	D ₀ ²	H ₃	
	M	W	L														
NR 75R NR 75LR	83	145	218 274	95	80 130	M18×25	170.2 226.2	25.3	68	18	16	B-PT1/8	9	17	8.2	15	
NR 85R NR 85LR	90	156	246.7 302.8	100	80 140	M18×25	194.9 251	27.3	73	20	16	B-PT1/8	10	20	8.2	17	
NR 100R NR 100LR	105	200	286.2 326.2	130	150 200	M18×27	223.4 263.4	34.3	85	23	10	B-PT1/4	12	23	8.2	20	
NRS 75R NRS 75LR	83	145	218 274	95	80 130	M18×25	170.2 226.2	25.3	68	18	16	B-PT1/8	9	17	8.2	15	
NRS 85R NRS 85LR	90	156	246.7 302.8	100	80 140	M18×25	194.9 251	27.3	73	20	16	B-PT1/8	10	20	8.2	17	
NRS 100R NRS 100LR	105	200	286.2 326.2	130	150 200	M18×27	223.4 263.4	34.3	85	23	10	B-PT1/4	12	23	8.2	20	

Model number coding

NR75 R 2 QZ KKHH C0 +1580L P Z T - II

Model number

Type of LM block

With QZ Lubricator

Contamination protection accessory symbol

LM rail length (in mm)

Symbol for LM rail jointed use

Symbol for No. of rails used on the same plane

No. of LM blocks used on the same rail

Radial clearance symbol
Normal (No symbol)
Light preload (C1)
Medium preload (C0)

With plate cover or steel tape

Accuracy symbol
Normal grade (No Symbol)/High accuracy grade (H)
Precision grade (P)/Super precision grade (SP)
Ultra precision grade (UP)

Notes: This model number indicates that a single-rail unit constitutes one set (i.e., required number of sets when 2 rails are used in parallel is 2 at a minimum).

Grease nipples are not installed when there is a QZ Lubricator. Contact THK if you want to use a grease nipple for a model with a QZ. See **A1-547** for contamination protection accessories. See **A1-73** for radial clearance symbol. See **A1-79** for accuracy symbol, specify either plate cover or steel tape. See **A1-13** for number of rails used on the same plane.

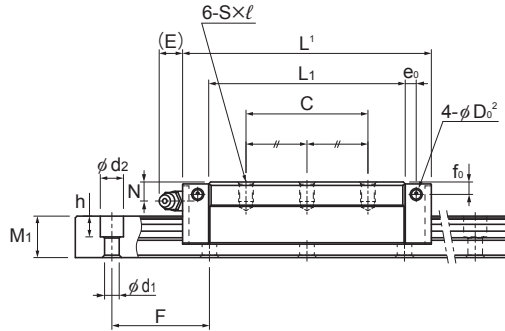

Models NR-LR and NRS-LR

Unit: mm

LM rail dimensions						Basic load rating ¹		Static permissible moment kN·m ⁵					Mass	
Width W ₁ 0 -0.05	W ₂	Height M ₁	Pitch F	Length ³ d ₁ × d ₂ × h	Max	C kN	C ₀ kN	M _A		M _B		M _C	LM block kg	LM rail kg/m
								1 block	2 blocks	1 block	2 blocks	1 block		
								1 block	2 blocks	1 block	2 blocks	1 block		
75	35	44	150	22 × 32 × 26	3000	271 355	610 800	14.4 25.4	73.3 118	8.91 15.4	44.7 71.4	19.3 25.2	8.7 11.6	24.6
85	35.5	48	180	24 × 35 × 28	3000	336 435	751 972	20.3 34.7	102 160	12.4 21	62.6 96.2	26.8 34.6	12.3 15.8	30.5
100	50	57	210	26 × 39 × 32	3000	479 599	1040 1300	34 47.3	167 238	20.7 29.2	101 146	43.4 54.6	21.8 26.1	42.6
75	35	44	150	22 × 32 × 26	3000	212 278	431 566	10.6 18.6	53.8 87	10.6 18.6	53.8 87	13.4 17.6	8.7 11.6	24.6
85	35.5	48	180	24 × 35 × 28	3000	264 342	531 687	14.9 25.4	75.3 117	14.9 25.4	75.3 117	18.7 24.2	12.3 15.8	30.5
100	50	57	210	26 × 39 × 32	3000	376 470	737 920	25.1 34.6	123 174	25.1 34.6	123 174	30.4 38.1	21.8 26.1	42.6

¹ Length L shown in the table is the length with the contamination protection accessories, code UU or SS.
If other contamination protection accessories or lubricant equipment are installed, the total block length will increase. (See [A1-521](#) or [A1-543](#))

² D₀ are the pilot holes for when a grease nipple is desired for a product with LaCS or a QZ Lubricator.
Pilot holes are not drilled through for models other than those stated above.
For grease nipple mount machining, contact THK.

³ The maximum length indicates the standard maximum length of an LM rail. (See [A1-246](#).)

⁴ The basic load rating is for a load in the radial direction.
Use [A1-61](#) on Table 7 to calculate the load rating for loads in the reverse-radial direction or lateral direction.

⁵ Static permissible moment 1 block: the static permissible moment with one LM block
2 blocks: the static permissible moment with two LM blocks in close contact with each other

Note: For oil lubrication, be certain to let THK know the mounting orientation and where the LM block piping joint should be attached.
(Mounting orientation: see [A1-12](#), Lubricant: see [A24-2](#))

Models NR-CX, NR-LCX, and NR-SLCX

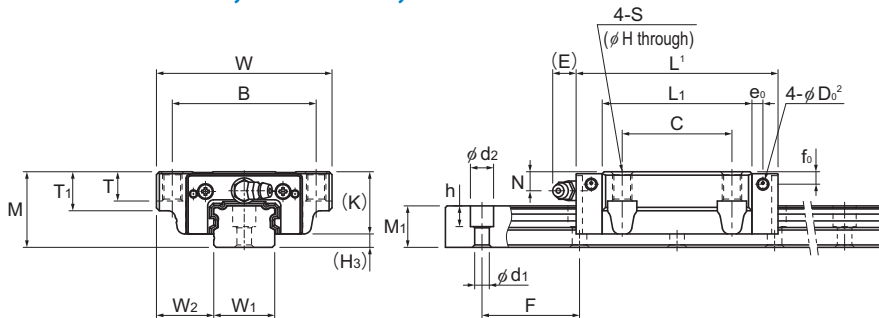

Model NR-CX

Model No.	Outer dimensions			LM block dimensions											Pilot hole for side nipple			
	Height	Width	Length ¹	B	C	S	H	L ₁	T	T ₁	K	N	E	Grease nipple	e ₀	f ₀	D ₀ ²	H ₃
	M	W	L															
NR 25CX NR 25LCX NR 25SLCX	31	72	82.8 102 170.3	45 59	45 100	M8	6.8	61.4 80.6 148.9	14.8	16	25.5	7.8	12	B-M6F	4.5	5.1	3.9	5.5
NR 30CX NR 30LCX NR 30SLCX	38	90	98 120.5 204.6	72	52 120	M10	8.5	72.1 94.6 178.7	16.9	18.1	31	10.3	12	B-M6F	6.5	7	3.9	7
NR 35CX NR 35LCX NR 35SLCX	44	100	109.5 135 238.9	82	62 140	M10	8.5	79 104.5 208.4	18.9	20.1	35	12.1	12	B-M6F	6	8	5.2	9
NR 45CX NR 45LCX NR 45SLCX	52	120	138.2 171 271.4	100	80 160	M12	10.5	105 137.8 238.2	20.6	22.1	40.4	13.9	16	B-PT1/8	8.5	8	5.2	11.6
NR 55CX NR 55LCX NR 55SLCX	63	140	163.3 200.5 400.5	116	95 206	M14	12.5	123.6 160.8 360.8	22.5	24	49	16.6	16	B-PT1/8	10	10	5.2	14
NR 65CX NR 65LCX NR 65SLCX	75	170	186 246 422.2	142	110 250	M16	14.5	143.6 203.6 379.8	26	28	60	19	16	B-PT1/8	8.7	15	8.2	15

Model number coding

NR35 CX 2 QZ KKH C0 +1400L P T - II

Model number

Type of LM block

With QZ Lubricator

Contamination protection accessory symbol

LM rail length (in mm)

Symbol for LM rail jointed use

Symbol for No. of rails used on the same plane

No. of LM blocks used on the same rail

Radial clearance symbol
Normal (No symbol)
Light preload (C1)
Medium preload (C0)

Accuracy symbol
Normal grade (No Symbol)/High accuracy grade (H)
Precision grade (P)/Super precision grade (SP)
Ultra precision grade (UP)

Notes: This model number indicates that a single-rail unit constitutes one set (i.e., required number of sets when 2 rails are used in parallel is 2 at a minimum).

Grease nipples are not installed when there is a QZ Lubricator. Contact THK if you want to use a grease nipple for a model with a QZ. See **A1-547** for contamination protection accessories, see **A1-73** for radial clearance symbol. See **A1-79** for accuracy symbol. See **A1-13** for symbol for number of rails used on the same plane.

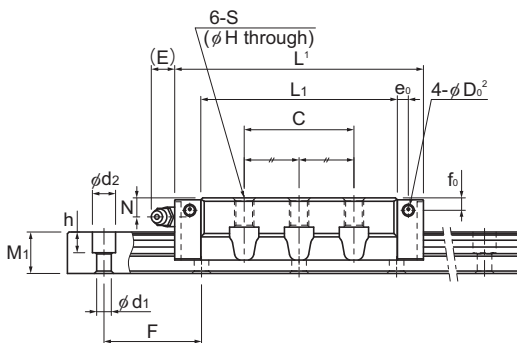

Models NR-LCX/SLCX

Unit: mm

LM rail dimensions						Basic load rating ¹⁾		Static permissible moment kN·m ⁵⁾					Mass	
Width W ₁ 0 -0.05	Height W ₂	Pitch M ₁	Pitch F	Length ³⁾ d ₁ × d ₂ × h	Length ³⁾ Max	C kN	C ₀ kN	M _A		M _B		M _C	LM block kg	LM rail kg/m
								1 block	2 blocks	1 block	2 blocks	1 block		
25	23.5	17	40	6 × 9.5 × 8.5	3000	37.1	68.1	0.57	3.04	0.346	1.84	0.703	0.6	2.9
						45.4	90.8	0.989	4.91	0.597	2.95	0.937		
						71	172.6	3.37	15.3	2.02	9.15	1.8		
28	31	21	80	7 × 11 × 9	3000	54.7	98.1	0.986	5.17	0.599	3.13	1.15	1.1	4.2
						66.9	130.8	1.71	8.34	1.03	5.02	1.53		
						104.8	248.6	5.82	26.4	3.49	15.8	2.95		
34	33	24.5	80	9 × 14 × 12	3000	72.4	124.6	1.37	7.38	0.835	4.48	1.74	1.6	6
						89.6	169.1	2.46	12.1	1.49	7.3	2.36		
						145.6	338.2	9.23	42	5.54	25.2	4.78		
45	37.5	29	105	14 × 20 × 17	3090	110.2	197.6	2.81	14.7	1.72	8.95	3.72	2.7	9.5
						132	255.8	4.87	23	2.94	13.8	4.81		
						193.5	441.8	13.8	62.3	8.27	37.3	8.32		
53	43.5	36.5	120	16 × 23 × 20	3060	141.9	250.2	4.22	21.8	2.56	13.2	5.37	4.5	14
						175.1	338.4	7.27	35.9	4.4	21.7	7.27		
						305.8	750.5	35.2	155	21.1	92.7	16.2		
63	53.5	43	150	18 × 26 × 22	3000	208.7	351.7	6.87	35	4.16	21.2	8.94	7.8	19.6
						268.9	505.5	13.8	65.4	8.31	39.3	12.9		
						423.1	967.1	47.9	211	28.7	126	24.8		

¹⁾ Length L shown in the table is the length with the contamination protection accessories, code UU or SS.
If other contamination protection accessories or lubricant equipment are installed, the total block length will increase. (See [A1-521](#) or [A1-543](#))

²⁾ D₀ are the pilot holes for when a grease nipple is desired for a product with LaCS or a QZ Lubricator.
Pilot holes are not drilled through for models other than those stated above.
For grease nipple mount machining, contact THK.

³⁾ The maximum length indicates the standard maximum length of an LM rail. (See [A1-246](#).)

⁴⁾ The basic load rating is for a load in the radial direction.
Use [A1-61](#) on Table 7 to calculate the load rating for loads in the reverse-radial direction or lateral direction.

⁵⁾ Static permissible moment 1 block: the static permissible moment with one LM block
2 blocks: the static permissible moment with two LM blocks in close contact with each other

Note: For oil lubrication, be certain to let THK know the mounting orientation and where the LM block piping joint should be attached.
(Mounting orientation: see [A1-12](#), Lubricant: see [A24-2](#))

Models NRS-CX, NRS-LCX, and NRS-SLCX

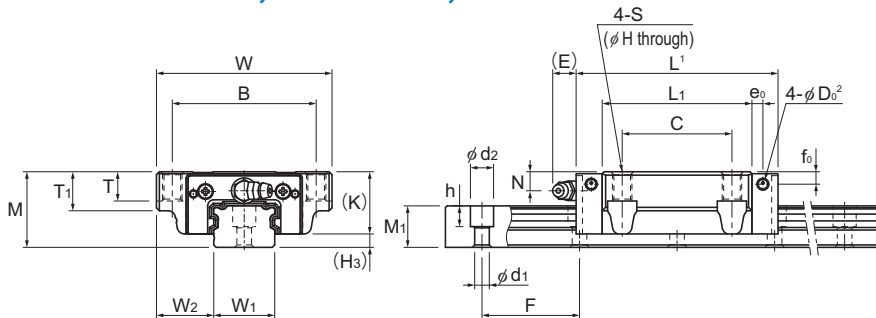

Model NRS-CX

Model No.	Outer dimensions			LM block dimensions											Pilot hole for side nipple			
	Height M	Width W	Length ¹ L	B	C	S	H	L ₁	T	T ₁	K	N	E	Grease nipple	e ₀	f ₀	D ₀ ²	H ₃
NRS 25CX NRS 25LCX NRS 25SLCX	31	72	82.8 102 170.3	45 59	45 100	M8	6.8	61.4 80.6 148.9	14.8	16	25.5	7.8	12	B-M6F	4.5	5.1	3.9	5.5
NRS 30CX NRS 30LCX NRS 30SLCX	38	90	98 120.5 204.6	72	52 120	M10	8.5	72.1 94.6 178.7	16.9	18.1	31	10.3	12	B-M6F	6.5	7	3.9	7
NRS 35CX NRS 35LCX NRS 35SLCX	44	100	109.5 135 238.9	82	62 140	M10	8.5	79 104.5 208.4	18.9	20.1	35	12.1	12	B-M6F	6	8	5.2	9
NRS 45CX NRS 45LCX NRS 45SLCX	52	120	138.2 171 271.4	100	80 160	M12	10.5	105 137.8 238.2	20.6	22.1	40.4	13.9	16	B-PT1/8	8.5	8	5.2	11.6
NRS 55CX NRS 55LCX NRS 55SLCX	63	140	163.3 200.5 400.5	116	95 206	M14	12.5	123.6 160.8 360.8	22.5	24	49	16.6	16	B-PT1/8	10	10	5.2	14
NRS 65CX NRS 65LCX NRS 65SLCX	75	170	186 246 422.2	142	110 250	M16	14.5	143.6 203.6 379.8	26	28	60	19	16	B-PT1/8	8.7	15	8.2	15

Model number coding

NRS45 LCX 2 QZ SSHH C0 +2040L P T - II

Model number

Type of LM block

With QZ Lubricator

Contamination protection accessory symbol

LM rail length (in mm)

Symbol for LM rail jointed use

Symbol for No. of rails used on the same plane

No. of LM blocks used on the same rail

Radial clearance symbol
Normal (No symbol)
Light preload (C1)
Medium preload (C0)

Accuracy symbol
Normal grade (No Symbol)/High accuracy grade (H)
Precision grade (P)/Super precision grade (SP)
Ultra precision grade (UP)

Notes: This model number indicates that a single-rail unit constitutes one set (i.e., required number of sets when 2 rails are used in parallel is 2 at a minimum).

Grease nipples are not installed when there is a QZ Lubricator. Contact THK if you want to use a grease nipple for a model with a QZ. See **A1-547** for contamination protection accessories, see **A1-73** for radial clearance symbol. See **A1-79** for accuracy symbol. See **A1-13** for symbol for number of rails used on the same plane.

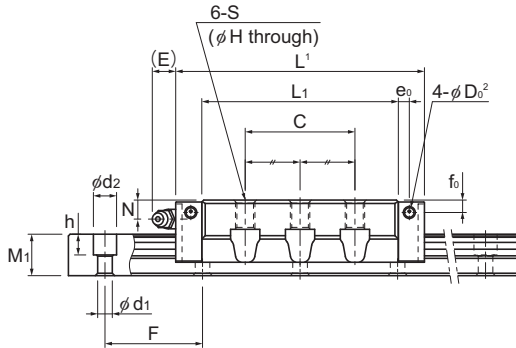

Models NRS-LCX/SLCX

Unit: mm

		LM rail dimensions					Basic load rating ¹⁾		Static permissible moment kN·m ⁵					Mass	
Width	Height	Pitch	Length ³⁾	C	C ₀	M _A		M _B		M _C	LM block	LM rail			
						1 block	2 blocks	1 block	2 blocks	1 block			kg	kg/m	
W ₁ 0 -0.05	W ₂	M ₁	F	d ₁ × d ₂ × h	Max	kN	kN								
25	23.5	17	40	6 × 9.5 × 8.5	3000	28.4	52.2	0.457	2.43	0.422	2.25	0.552	0.6	2.9	
						34.7	69.6	0.786	3.9	0.727	3.61	0.732	0.8		
						54.4	132.2	2.66	12.1	2.46	11.2	1.33	1.5		
28	31	21	80	7 × 11 × 9	3000	41.9	75.2	0.785	4.12	0.726	3.82	0.896	1.1	4.2	
						51.2	100.2	1.36	6.62	1.26	6.13	1.19	1.5		
						80.3	190.4	4.6	20.9	4.25	19.3	2.17	2.8		
34	33	24.5	80	9 × 14 × 12	3000	55.5	95.5	1.09	5.88	1.01	5.45	1.36	1.6	6	
						68.6	129.5	1.95	9.61	1.81	8.9	1.84	2		
						111.5	259.1	7.3	33.2	6.75	30.7	3.53	4		
45	37.5	29	105	14 × 20 × 17	3000	84.4	151.4	2.23	11.7	2.07	10.8	2.9	2.7	9.5	
						101.1	195.9	3.87	18.3	3.57	16.9	3.75	3.6		
						148.3	338.4	10.9	49.2	10.1	45.5	6.22	6.2		
53	43.5	36.5	120	16 × 23 × 20	3000	108.7	191.6	3.36	17.4	3.1	16.1	4.19	4.5	14	
						134.1	259.3	5.76	28.4	5.32	26.3	5.67	5.9		
						234.3	574.9	27.8	123	25.7	113	12	13.2		
63	53.5	43	150	18 × 26 × 22	3000	159.8	269.4	5.46	27.8	5.05	25.8	6.97	7.8	19.6	
						206	387.2	10.9	51.9	10.1	48	10.02	11		
						324.1	740.8	37.9	167	35	154	18.4	20.5		

¹ Length L shown in the table is the length with the contamination protection accessories, code UU or SS.
If other contamination protection accessories or lubricant equipment are installed, the total block length will increase. (See **A1-521** or **A1-543**)

² D₀ are the pilot holes for when a grease nipple is desired for a product with LaCS or a QZ Lubricator.
Pilot holes are not drilled through for models other than those stated above.
For grease nipple mount machining, contact THK.

³ The maximum length indicates the standard maximum length of an LM rail. (See **A1-246**.)

⁴ The basic load rating is for a load in the radial direction.

Use **A1-61** on Table 7 to calculate the load rating for loads in the reverse-radial direction or lateral direction.

⁵ Static permissible moment 1 block: the static permissible moment with one LM block
2 blocks: the static permissible moment with two LM blocks in close contact with each other

Note: For oil lubrication, be certain to let THK know the mounting orientation and where the LM block piping joint should be attached.
(Mounting orientation: see **A1-12**, Lubricant: see **A24-2**)

Models NR-A, NR-LA, NRS-A, and NRS-LA

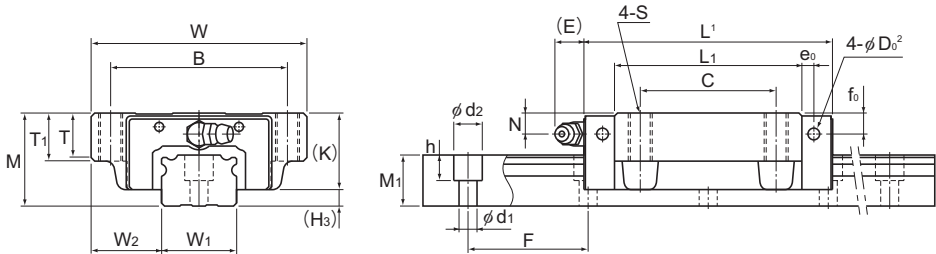

Models NR-A and NRS-A

Model No.	Outer dimensions			LM block dimensions											Pilot hole for side nipple			
	Height	Width	Length	B	C	S × ℓ	L ₁	T	T ₁	K	N	E	Grease nipple	e ₀	f ₀	D ₀ ²	H ₃	
	M	W	L															
NR 75A NR 75LA	83	195	218 274	165	130	M18 × 30	170.2 226.2	28	30	68	18	16	B-PT1/8	9	17	8.2	15	
NR 85A NR 85LA	90	215	246.7 302.8	185	140	M20 × 34	194.9 251	32	34	73	20	16	B-PT1/8	10	20	8.2	17	
NR 100A NR 100LA	105	260	286.2 326.2	220	150 200	M20 × 38	223.4 263.4	35	38	85	23	10	B-PT1/4	12	23	8.2	20	
NRS 75A NRS 75LA	83	195	218 274	165	130	M18 × 30	170.2 226.2	28	30	68	18	16	B-PT1/8	9	17	8.2	15	
NRS 85A NRS 85LA	90	215	246.7 302.8	185	140	M20 × 34	194.9 251	32	34	73	20	16	B-PT1/8	10	20	8.2	17	
NRS 100A NRS 100LA	105	260	286.2 326.2	220	150 200	M20 × 38	223.4 263.4	35	38	85	23	10	B-PT1/4	12	23	8.2	20	

Model number coding

NR75 A 2 QZ KKHH C0 +1580L P Z T - II

Model number	Type of LM block	With QZ Lubricator	Contamination protection accessory symbol	LM rail length (in mm)	Symbol for LM rail jointed use	Symbol for No. of rails used on the same plane
NR75	A	2	QZ	KKHH	C0	+1580L P Z T - II
	No. of LM blocks used on the same rail		Radial clearance symbol Normal (No symbol) Light preload (C1) Medium preload (C0)		With plate cover or steel tape	
				Accuracy symbol Normal grade (No Symbol)/High accuracy grade (H) Precision grade (P)/Super precision grade (SP) Ultra precision grade (UP)		

Notes: This model number indicates that a single-rail unit constitutes one set (i.e., required number of sets when 2 rails are used in parallel is 2 at a minimum).

Grease nipples are not installed when there is a QZ Lubricator. Contact THK if you want to use a grease nipple for a model with a QZ. See [A1-547](#) for contamination protection accessories. See [A1-73](#) for radial clearance symbol. See [A1-79](#) for accuracy symbol, specify either plate cover or steel tape. See [A1-13](#) for number of rails used on the same plane.

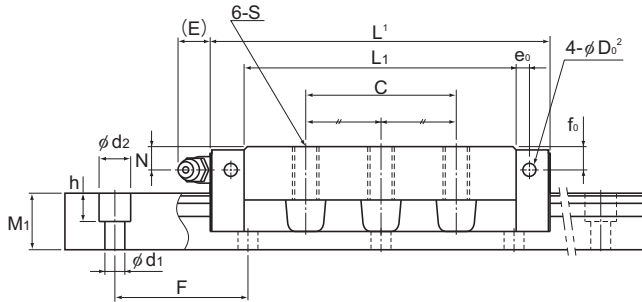

Models NR-LA and NRS-LA

Unit: mm

		LM rail dimensions					Basic load rating ¹⁾		Static permissible moment kN·m ⁵					Mass	
Width W ₁ 0 -0.05	W ₂	Height M ₁	Pitch F	d ₁ × d ₂ × h	Length ³⁾ Max	C kN	C ₀ kN	M _A		M _B		M _C	LM block kg	LM rail kg/m	
								1 block	2 blocks	1 block	2 blocks	1 block			
75	60	44	150	22 × 32 × 26	3000	271 355	610 800	14.4 25.4	73.3 118	8.91 15.4	44.7 71.4	19.3 25.2	11.3 15	24.6	
85	65	48	180	24 × 35 × 28	3000	336 435	751 972	20.3 34.7	102 160	12.4 21	62.6 96.2	26.8 34.6	16.2 20.7	30.5	
100	80	57	210	26 × 39 × 32	3000	479 599	1040 1300	34 47.3	167 238	20.7 29.2	101 146	43.4 54.6	26.7 31.2	42.6	
75	60	44	150	22 × 32 × 26	3000	212 278	431 566	10.6 18.6	53.8 87	10.6 18.6	53.8 87	13.4 17.6	11.3 15	24.6	
85	65	48	180	24 × 35 × 28	3000	264 342	531 687	14.9 25.4	75.3 117	14.9 25.4	75.3 117	18.7 24.2	16.2 20.7	30.5	
100	80	57	210	26 × 39 × 32	3000	376 470	737 920	25.1 34.6	123 174	25.1 34.6	123 174	30.4 38.1	26.7 31.2	42.6	

¹⁾ Length L shown in the table is the length with the contamination protection accessories, code UU or SS.
If other contamination protection accessories or lubricant equipment are installed, the total block length will increase. (See [A1-521](#) or [A1-543](#))

²⁾ D₀ are the pilot holes for when a grease nipple is desired for a product with LaCS or a QZ Lubricator.
Pilot holes are not drilled through for models other than those stated above.
For grease nipple mount machining, contact THK.

³⁾ The maximum length indicates the standard maximum length of an LM rail. (See [A1-246](#).)

⁴⁾ The basic load rating is for a load in the radial direction.

Use [A1-61](#) on Table 7 to calculate the load rating for loads in the reverse-radial direction or lateral direction.

⁵⁾ Static permissible moment 1 block: the static permissible moment with one LM block
2 blocks: the static permissible moment with two LM blocks in close contact with each other

Note: For oil lubrication, be certain to let THK know the mounting orientation and where the LM block piping joint should be attached.
(Mounting orientation: see [A1-12](#), Lubricant: see [A24-2](#))

Models NR-B, NR-LB, NRS-B, and NRS-LB

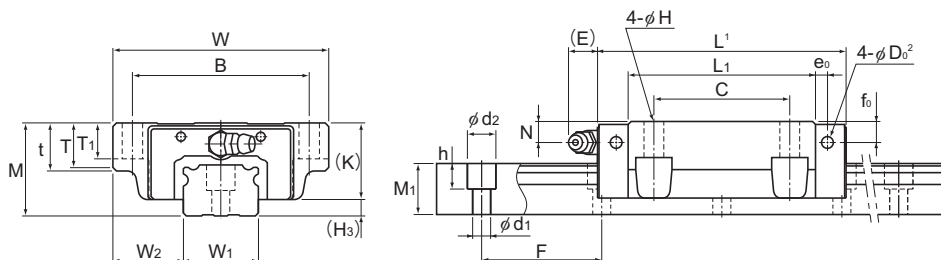

Models NR-B and NRS-B

Model No.	Outer dimensions			LM block dimensions													Pilot hole for side nipple			
	Height	Width	Length ¹	B	C	H	L ₁	t	T	T ₁	K	N	E	Grease nipple	e ₀	f ₀	D ₀ ²	H ₃		
	M	W	L																	
NR 75B NR 75LB	83	195	218 274	165	130	18	170.2 226.2	30	28	26	68	18	16	B-PT1/8	9	17	8.2	15		
NR 85B NR 85LB	90	215	246.7 302.8	185	140	18	194.9 251	34	32	28	73	20	16	B-PT1/8	10	20	8.2	17		
NR 100B NR 100LB	105	260	286.2 326.2	220	150 200	20	223.4 263.4	38	35	32	85	23	10	B-PT1/4	12	23	8.2	20		
NRS 75B NRS 75LB	83	195	218 274	165	130	18	170.2 226.2	30	28	26	68	18	16	B-PT1/8	9	17	8.2	15		
NRS 85B NRS 85LB	90	215	246.7 302.8	185	140	18	194.9 251	34	32	28	73	20	16	B-PT1/8	10	20	8.2	17		
NRS 100B NRS 100LB	105	260	286.2 326.2	220	150 200	20	223.4 263.4	38	35	32	85	23	10	B-PT1/4	12	23	8.2	20		

Model number coding

NR75 B 2 QZ DDHH C0 +1580L P Z T -II

Model number

Type of LM block

With QZ Lubricator

Contamination protection accessory symbol

LM rail length (in mm)

Symbol for LM rail jointed use

Symbol for No. of rails used on the same plane

No. of LM blocks used on the same rail

Radial clearance symbol
Normal (No symbol)
Light preload (C1)
Medium preload (C0)

With plate cover or steel tape

Accuracy symbol
Normal grade (No Symbol)/High accuracy grade (H)
Precision grade (P)/Super precision grade (SP)
Ultra precision grade (UP)

Notes: This model number indicates that a single-rail unit constitutes one set (i.e., required number of sets when 2 rails are used in parallel is 2 at a minimum).

Grease nipples are not installed when there is a QZ Lubricator. Contact THK if you want to use a grease nipple for a model with a QZ.

See **A1-547** for contamination protection accessories. See **A1-73** for radial clearance symbol. See **A1-79** for accuracy symbol, specify either plate cover or steel tape. See **A1-13** for number of rails used on the same plane.

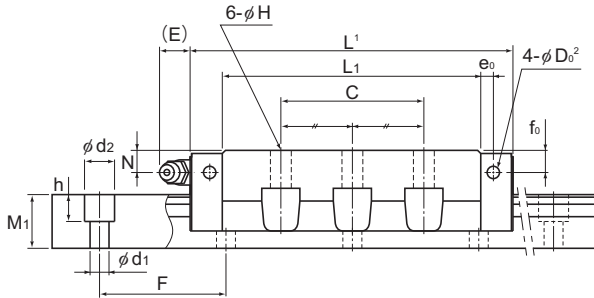

Models NR-LB and NRS-LB

Unit: mm

LM rail dimensions						Basic load rating ¹⁾		Static permissible moment kN·m ⁵⁾					Mass	
Width W ₁ 0 -0.05	Height W ₂	Pitch M ₁	Pitch F	Length ³⁾ d ₁ × d ₂ × h	Length ³⁾ Max	C kN	C ₀ kN	M _A		M _B		M _C	LM block kg	LM rail kg/m
								1 block	2 blocks	1 block	2 blocks	1 block		
75	60	44	150	22 × 32 × 26	3000	271 355	610 800	14.4 25.4	73.3 118	8.91 15.4	44.7 71.4	19.3 25.2	11.3 15	24.6
85	65	48	180	24 × 35 × 28	3000	336 435	751 972	20.3 34.7	102 160	12.4 21	62.6 96.2	26.8 34.6	16.2 20.7	30.5
100	80	57	210	26 × 39 × 32	3000	479 599	1040 1300	34 47.3	167 238	20.7 29.2	101 146	43.4 54.6	26.7 31.2	42.6
75	60	44	150	22 × 32 × 26	3000	212 278	431 566	10.6 18.6	53.8 87	10.6 18.6	53.8 87	13.4 17.6	11.3 15	24.6
85	65	48	180	24 × 35 × 28	3000	264 342	531 687	14.9 25.4	75.3 117	14.9 25.4	75.3 117	18.7 24.2	16.2 20.7	30.5
100	80	57	210	26 × 39 × 32	3000	376 470	737 920	25.1 34.6	123 174	25.1 34.6	123 174	30.4 38.1	26.7 31.2	42.6

¹⁾ Length L shown in the table is the length with the contamination protection accessories, code UU or SS.

If other contamination protection accessories or lubricant equipment are installed, the total block length will increase. (See [A1-521](#) or [A1-543](#))

²⁾ D₀ are the pilot holes for when a grease nipple is desired for a product with LaCS or a QZ Lubricator.

Pilot holes are not drilled through for models other than those stated above.

For grease nipple mount machining, contact THK.

³⁾ The maximum length indicates the standard maximum length of an LM rail. (See [A1-246](#).)

⁴⁾ The basic load rating is for a load in the radial direction.

Use [A1-61](#) on Table 7 to calculate the load rating for loads in the reverse-radial direction or lateral direction.

⁵⁾ Static permissible moment 1 block: the static permissible moment with one LM block

2 blocks: the static permissible moment with two LM blocks in close contact with each other

Note: For oil lubrication, be certain to let THK know the mounting orientation and where the LM block piping joint should be attached.

(Mounting orientation: see [A1-12](#), Lubricant: see [A24-2](#))

Standard Lengths and Maximum Lengths of LM Rails

Table 1 shows the standard lengths and the maximum lengths of models NR-X/NRS-X variations. If the maximum length of the desired LM rail exceeds these values, jointed rails will be used. Contact THK for details.

For special rail lengths, it is recommended to use a value corresponding to the G and g dimensions from the table. As the G and g dimensions increase, this portion becomes less stable, and the accuracy performance is severely impacted.

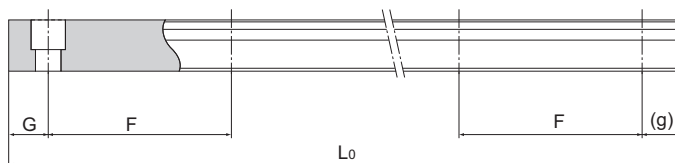

Table 1: Standard Lengths and Maximum Lengths of LM Rails for Models NR-X/NRS-X

Unit: mm

Model No.	NR/NRS25X	NR/NRS30X	NR/NRS35X	NR/NRS45X	NR/NRS55X	NR/NRS65X	NR/NRS75	NR/NRS85	NR/NRS100
LM rail standard lengths (L_0)	230	280	280	570	780	1270	1280	1530	1340
	270	360	360	675	900	1570	1580	1890	1760
	350	440	440	780	1020	2020	2030	2250	2180
	390	520	520	885	1140	2620	2630	2610	2600
	470	600	600	990	1260				
	510	680	680	1095	1380				
	590	760	760	1200	1500				
	630	840	840	1305	1620				
	710	920	920	1410	1740				
	750	1000	1000	1515	1860				
	830	1080	1080	1620	1980				
	950	1160	1160	1725	2100				
	990	1240	1240	1830	2220				
	1070	1320	1320	1935	2340				
	1110	1400	1400	2040	2460				
	1190	1480	1480	2145	2580				
	1230	1560	1560	2250	2700				
	1310	1640	1640	2355	2820				
	1350	1720	1720	2460	2940				
	1430	1800	1800	2565	3060				
	1470	1880	1880	2670					
	1550	1960	1960	2775					
	1590	2040	2040	2880					
	1710	2200	2200	2985					
1830	2360	2360	3090						
1950	2520	2520							
2070	2680	2680							
2190	2840	2840							
2310	3000	3000							
2430									
2470									
Standard pitch F	40	80	80	105	120	150	150	180	210
G, g	15	20	20	22.5	30	35	40	45	40
Max length	3000	3000	3000	3090	3060	3000	3000	3000	3000

Notes: The maximum length varies with accuracy grades. Contact THK for details.

If jointed rails are not allowed and a greater length than the maximum values above is required, contact THK.

