

# HCR

## Curved LM Guide Model HCR

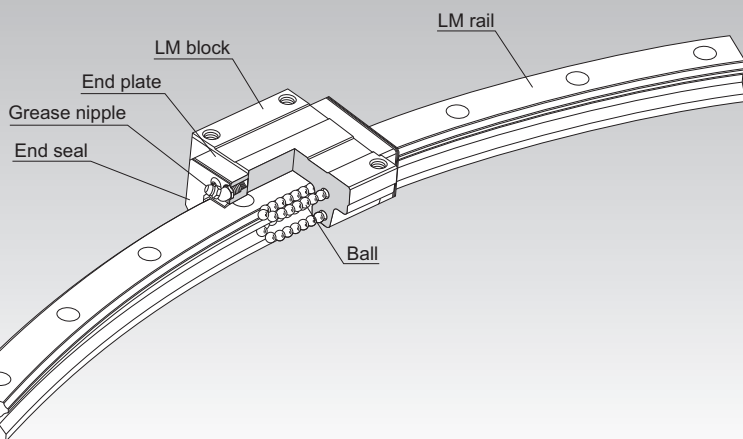

**Selection Criteria** **A1-10**

**Design Highlights** **A1-482**

**Options** **A1-507**

**Model No.** **A1-577**

**Handling Precautions** **A1-583**

**Accessories for Lubrication** **A24-1**

**Mounting Procedure** **B1-89**

Equivalent Moment Factor **A1-43**

Rated Loads in All Directions **A1-61**

Equivalent Factor in Each Direction **A1-63**

Radial Clearance **A1-75**

Accuracy Standards **A1-81**

Shoulder Height of the Mounting Base and the Corner Radius **A1-493**

Dimensions of Each Model with Options Attached **A1-521**

---

## Structure and Features

---

Balls roll in four rows of raceways precision-ground on an LM rail and an LM block, and end plates incorporated in the LM block allow the balls to circulate.

The curved guide is capable of achieving highly accurate circular motion. It is a novel product with the same basic structure as the successful LM Guide Model HSR, which can bear an equal load in four directions.

### Freedom of Design

Multiple LM blocks can individually move on the same rail. By arranging LM blocks on the load points, efficient structural design is achieved.

### Shortened Assembly Time

This model allows clearance-free, highly accurate circular motion as opposed to sliding guides or cam followers. You can easily assemble this model simply by mounting the LM rail and LM blocks with bolts.

### Allows Circular Motion of 5 m or Longer

It allows circular motion of 5 m or longer, which is impossible with swivel bearings. In addition, use of this model makes it easy to assemble, disassemble, and reassemble equipment that moves in a circular path.

### Capable of Receiving a Load in Any Direction

This model is capable of receiving loads in all directions since it has the same basic structure as Model HSR.

---

## Types and Features

---

### Model HCR

Dimensional Table → **A1-338**

The flange of its LM block has tapped holes.

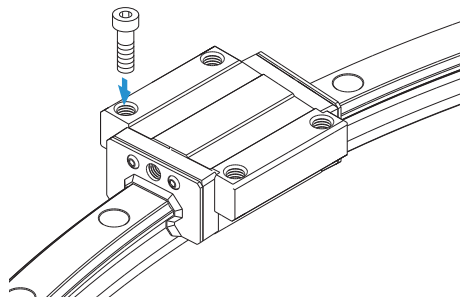



# Curved LM Guide Model HCR

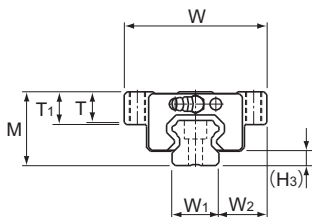

Model No.	Outer dimensions			LM block dimensions									H <sub>3</sub>
	Height	Width	Length <sup>1</sup>	B	C	S	L <sub>1</sub>	T	T <sub>1</sub>	N	E	Grease nipple	
	M	W	L										
HCR 12A+60/100R	18	39	44.6	32	18	M4	30.5	4.5	5	3.4	3.5	PB107	3.1
HCR 15A+60/150R	24	47	54.5	38	24	M5	38.8	10.3	11	4.5	5.5	PB1021B	4.8
HCR 15A+60/300R			55.5										
HCR 15A+60/400R			55.8										
HCR 25A+60/500R	36	70	81.6	57	45	M8	59.5	14.9	16	6	12	B-M6F	7
HCR 25A+60/750R			82.3										
HCR 25A+60/1000R			82.5										
HCR 35A+60/600R	48	100	107.2	82	58	M10	80.4	19.9	21	8	12	B-M6F	8.5
HCR 35A+60/800R			107.5										
HCR 35A+60/1000R			108.2										
HCR 35A+60/1300R			108.5										
HCR 45A+60/800R	60	120	136.7	100	70	M12	98	23.9	25	10	16	B-PT1/8	11.5
HCR 45A+60/1000R			137.3										
HCR 45A+60/1200R			137.3										
HCR 45A+60/1600R			138										
HCR 65A+60/1000R	90	170	193.8	142	106	M16	147	34.9	37	19	16	B-PT1/8	15
HCR 65A+60/1500R			195.4										
HCR 65A+45/2000R			195.9										
HCR 65A+45/2500R			196.5										
HCR 65A+30/3000R			196.5										

## Model number coding

**HCR25A 2 UU C1 +60 / 1000R H 6 T**

Model number

Contamination protection accessory symbol

R-Guide center angle

LM rail radius (in mm)

Symbol for LM rail jointed use

No. of LM blocks used on the same rail

Radial clearance symbol  
Normal (No symbol)  
Light preload (C1)

Accuracy symbol  
Normal grade (No Symbol)  
High accuracy grade (H)

Number of LM rail joints used on one axis

Notes: See **A1-547** for contamination protection accessories. See **A1-75** for radial clearance. See **A1-81** for accuracy code. This is the number of LM rails used for one arc. Contact THK for details. When using joined LM rails for models HCR15 to 65, the contamination protection seal must be a low-resistance end seal.

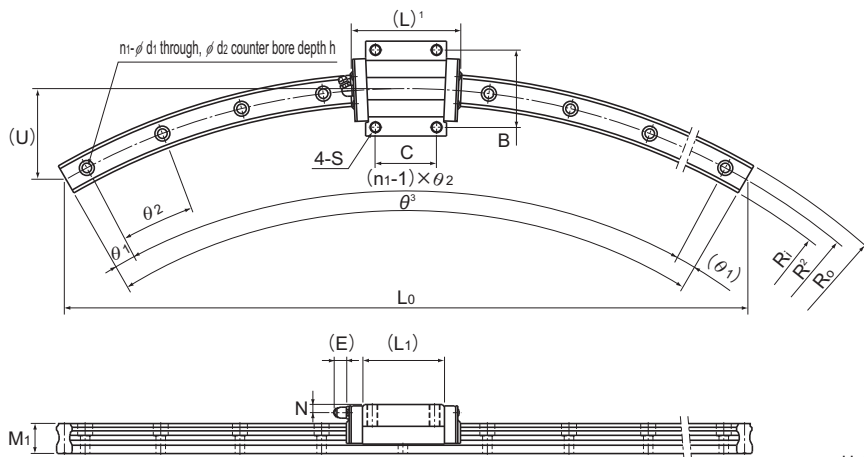

Unit: mm

LM rail dimensions														Basic load rating		Static permissible moment kN·m <sup>4</sup>					Mass	
R <sup>2</sup>	R <sub>0</sub>	R <sub>i</sub>	L <sub>0</sub>	U	Width		Height	d <sub>i</sub> × d <sub>2</sub> × h	n <sub>i</sub>	θ <sup>3</sup>	θ <sub>1</sub> <sup>3</sup>	θ <sub>2</sub> <sup>3</sup>	C	C <sub>0</sub>	M <sub>A</sub>		M <sub>B</sub>		M <sub>C</sub>	LM block kg	LM rail kg/m	
					W <sub>1</sub>	W <sub>2</sub>									1 block	2 blocks	1 block	2 blocks	1 block			
100	106	94	100	13.4	12	13.5	11	3.5×6×5	3	60	7	23	4.7	8.53	0.0409	0.228	0.0409	0.228	0.0445	0.08	0.83	
150	157.5	142.5	150	20.1																		
300	307.5	292.5	300	40	15	16	15	4.5×7.5×5.3	5	60	6	12	8.33	13.5	0.0805	0.457	0.0805	0.457	0.0844	0.2	1.5	
400	407.5	392.5	400	54																		
500	511.5	488.5	500	67																		
750	761.5	738.5	750	100	23	23.5	22	7×11×9	12	60	2.5	5	19.9	34.4	0.307	1.71	0.307	1.71	0.344	0.59	3.3	
1000	1011.5	988.5	1000	134																		
600	617	583	600	80																		
800	817	783	800	107	34	33	29	9×14×12	11	60	2.5	5.5	37.3	61.1	0.782	3.93	0.782	3.93	0.905	1.6	6.6	
1000	1017	983	1000	134																		
1300	1317	1283	1300	174																		
800	822.5	777.5	800	107																		
1000	1022.5	977.5	1000	134	45	37.5	38	14×20×17	10	60	3	6	60	95.6	1.42	7.92	1.42	7.92	1.83	2.8	11	
1200	1222.5	1177.5	1200	161																		
1600	1622.5	1577.5	1600	214																		
1000	1031.5	968.5	1000	134																		
1500	1531.5	1468.5	1500	201																		
2000	2031.5	1968.5	1531	152	63	53.5	53	18×26×22	12	45	0.5	4	141	215	4.8	23.5	4.8	23.5	5.82	8.5	22.5	
2500	2531.5	2468.5	1913	190																		
3000	3031.5	2968.5	1553	102																		

<sup>1</sup> Length L shown in the table is the length with the contamination protection accessories, code UU or SS.

If other contamination protection accessories or lubricant equipment are installed, the total block length will increase. (See **A1-521** or **A1-543**)

<sup>2</sup> R is the radius of the curve in the LM rail. Radii other than those shown in the table are also available. Contact THK for details.

<sup>3</sup> θ<sup>3</sup> is the maximum manufacturing angle. Exceeding this angle is normally done by using a joint; however, some products may have LM rails that exceed the maximum manufacturing angle. Contact THK for details.

<sup>4</sup> Static permissible moment 1 block: the static permissible moment with one LM block

2 blocks: the static permissible moment with two LM blocks in close contact with each other

Note: Please be aware that the balls will fall out of the LM block if it is removed from the LM rail.