

# Model LFH-X

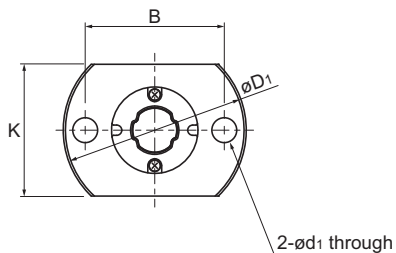

Models LFH5X to 13X

Model No.	Spline shaft diameter		Spline nut dimensions												
	D <sub>0</sub> h7	Outer diameter		Length			Flange outer diameter		B	C	H	F	E	E <sub>1</sub>	Lubrication hole d <sub>0</sub>
		D	Tolerance	L (With seal)	L <sub>1</sub> (Without seal)	L <sub>2</sub>	D <sub>1</sub>	K							
LFH 5X LFH 5XL	5	10	<sup>0</sup> -0.009	15 26	13.6 24.6	7.3 18.3	23	16	17	—	2.7	<sup>—</sup> 6.5	6.55	5.35	<sup>—</sup> 1
LFH 6X LFH 6XL	6	12	<sup>0</sup> -0.011	19 30	17.6 28.6	10.2 21.2	25	18	19	—	2.7	<sup>2.4</sup> 7.9	7.1	5.9	1
LFH 8X LFH 8XL	8	15	<sup>0</sup> -0.011	25 40	23.8 38.8	14.6 29.6	28	21	22	—	3.8	<sup>3.5</sup> 11	9	7.5	1.5
LFH 10X	10	19	<sup>0</sup> -0.013	33	30.8	23.9	38	25	29	—	6	5.95	10.55	9.45	1.5
LFH 13X	13	23	<sup>0</sup> -0.013	36	32.4	24	43	29	33	—	6	6	12	10.2	1.5
LFH 16X	16	28	<sup>0</sup> -0.013	50	46.4	35.5	48	34	31	22	6	11.7	13.3	11.5	2
LFH 20X	20	32	<sup>0</sup> -0.016	63	59	47.4	54	38	36	24	8	15.7	15.8	13.8	2
LFH 25X	25	40	<sup>0</sup> -0.016	71	67	52.6	62	46	40	32	8	18.3	17.2	15.2	3
LFH 30X	30	45	<sup>0</sup> -0.016	80	75.6	59.6	74	51	49	35	10	19.8	20.2	18	3

## Model number coding

**2 LFH20X UU CL +700L P K**

Model No.

Number of spline nuts  
on one shaft  
(no symbol for one nut)

Symbol for clearance  
in the rotational direction<sup>2</sup>

Contamination protection  
accessory symbol<sup>1</sup>

Accuracy  
symbol<sup>3</sup>

Overall spline shaft length<sup>5</sup>  
(in mm)

Symbol for spline shaft<sup>4</sup>

<sup>1</sup> See **A3-128**. <sup>2</sup> See **A3-32**. <sup>3</sup> See **A3-37**. <sup>4</sup> See **A3-95**. <sup>5</sup> See **A3-123**.

# Medium-Torque Ball Spline

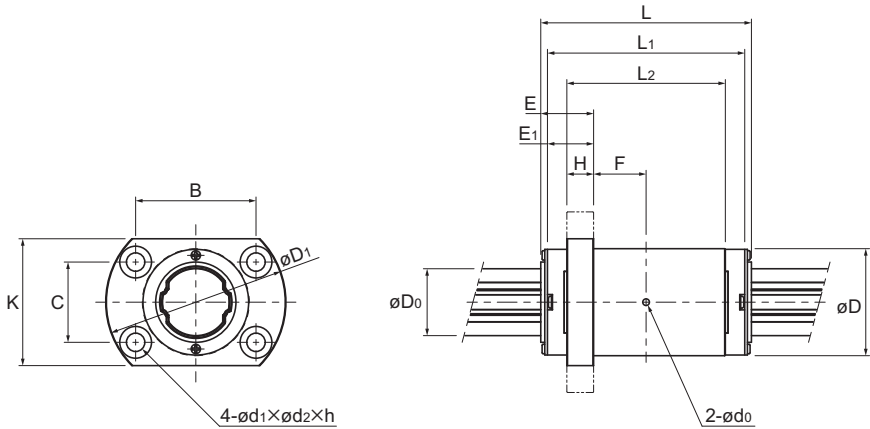

Models LFH16X to 30X

Unit: mm

	Mounting hole $d_1 \times d_2 \times h$	Basic torque rating		Basic load rating		Static permissible moment			Mass	
		$C_T$ N·m	$C_{OT}$ N·m	C kN	$C_0$ kN	$M_{A1}$ N·m	$M_{A2}$ (With seal) N·m	$M_{A2}$ (Without seal) N·m	Spline nut g	Spline shaft kg/m
	3.4 through	0.82 1.59	1.25 3.2	0.56 1.09	0.85 2.19	1.04 6.11	8.2 35.5	6.6 28.4	8.6 13.3	0.15
	3.4 through	1.73 2.81	2.77 5.54	0.98 1.6	1.58 3.15	2.85 10.6	19 59.8	15.2 47.8	12.4 19.1	0.21
	3.4 through	6 10.1	9.23 19.5	1.39 2.35	2.15 4.53	5.13 21.1	34.3 110.9	27.4 88.7	24.4 34.4	0.38
	4.5 through	9.41	17.3	2.94	5.4	21.5	114	104	59	0.59
	4.5 through	17.1	28.7	4.16	6.96	28.9	164	149	71	1.01
	4.5 × 8 × 4.4	42.9	68.6	8.4	13.4	77.4	419	381	116	1.52
	5.5 × 9.5 × 5.4	66.4	117	10.5	18.6	144	735	669	186	2.41
	5.5 × 9.5 × 5.4	125	207	15.9	26.2	230	1,183	1,077	306	3.71
	6.6 × 11 × 6.5	196	319	20.8	34	335	1,714	1,560	422	5.37

Notes: The mass of the spline nut does not include the seal.  
Please check the spline shaft strength tests (A3-12) before use.